

PANORAMA PG36

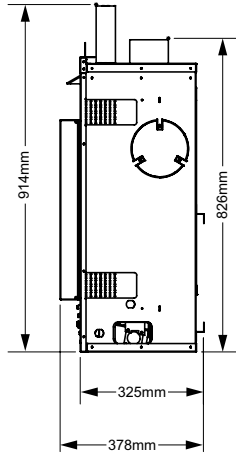
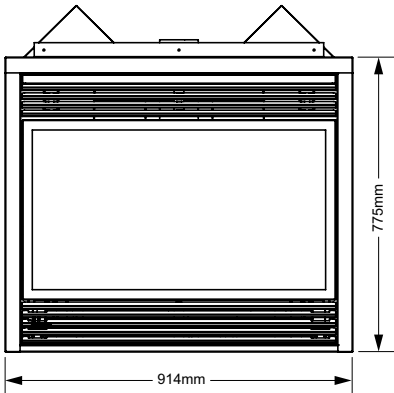

Standard Framing Dimensions			
A	B	C	D
921mm	921mm	324mm	1169mm*
Framing Dimensions with Premium Flush Front Option			
A	B	C	D
944mm	946mm	432mm	1182mm*

* 'D' is Minimum height to combustible materials including the Minimum 51mm Top clearance to the Horizontal Flue, see flue clearances in section "Clearances."

PG36-6 System Data		
Model	PG36NG-6	PG36LP-6
Fuel Type	Natural Gas	Propane
Gas Consumption	33mj	31mj
Manifold Pressure	0.9 kPa	2.6 kPa
Injector Size	#37	#52

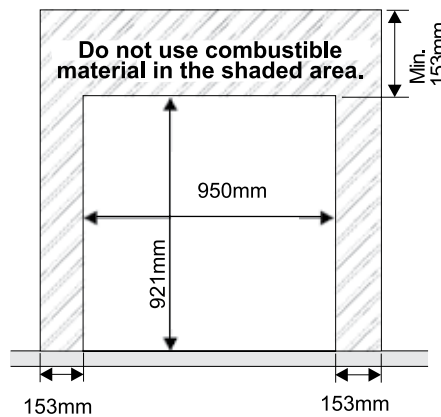
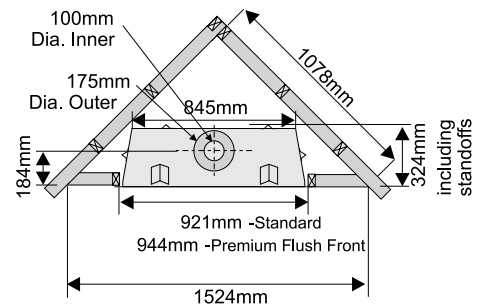
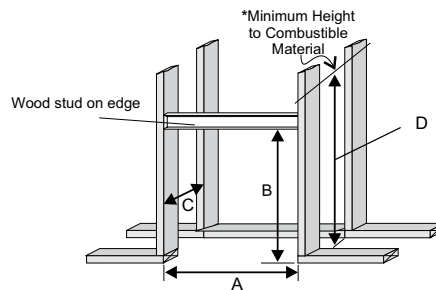

MINIMUM THICKNESS OF THE FINISHING MATERIAL: 12 mm

COMBUSTIBLE MANTELS

Due to the extreme heat this fireplace emits, the mantel clearances are critical. Combustible mantel clearances from the top of unit are shown in the diagrams below.

Note: A non-combustible mantel may be installed at a lower height if the framing is made of metal studs covered with a non-combustible board.

Note: Ensure the paint that is used on the mantel and the facing is "heat resistant" or the paint may discolour.

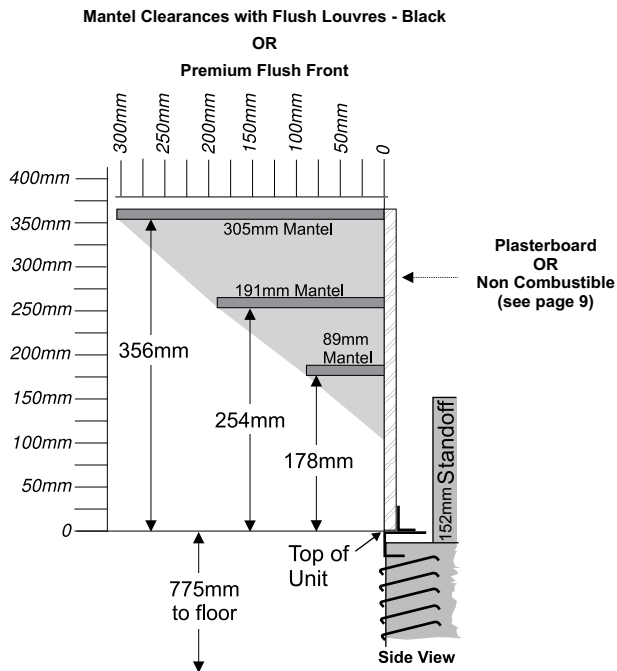

FLUEING ARRANGEMENTS - HORIZONTAL TERMINATIONS SIMPSON DURA-VENT DIRECT FLUE GS SYSTEM AND REGENCY® DIRECT FLUE SYSTEM (FLEX) (PROPANE & NG)

The diagram shows all allowable combinations of vertical runs with horizontal terminations, using one 90° elbow (two 45° elbows equal one 90° elbow).

Note: Must use optional flue adapter (Part # 510-994) when using Simpson Dura-Vent pipe.

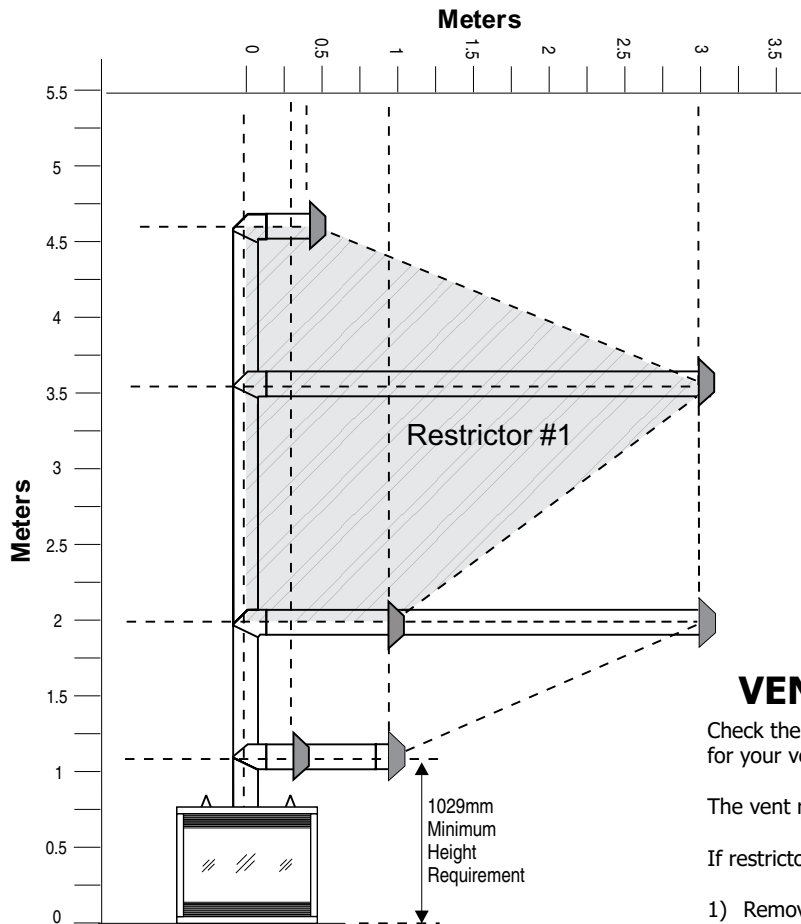

Simpson Dura-Vent
102mm inner diameter
168mm outer diameter

Regency® Flex Vent
102mm inner diameter
175mm outer diameter

A flue guard should be used whenever the termination is lower than the specified minimum or as per local codes.

Note: Regency® Co Axial Flue System (Flex) is only approved for horizontal terminations.

VENT RESTRICTOR INSTALLATION

Check the vent diagrams to determine whether the vent restrictor is needed for your vent configuration.

The vent restrictor is packaged with the manuals inside the firebox.

If restrictor is required:

- 1) Remove the top louver.
- 2) Open and remove the glass door front.
- 3) Remove the internal baffle (3 screws) at the top of the firebox.
- 4) Place the restrictor on the baffle plate (see diagram below) and re-install the internal baffle plate.

- Maintain clearances to combustibles as listed in the "Clearances," "Locating Your Gas Fireplace," "Combustible Mantels," "Mantel Leg Clearances" & "Framing and Finishing" sections.
- Horizontal flue must be supported every 0.9 meters.

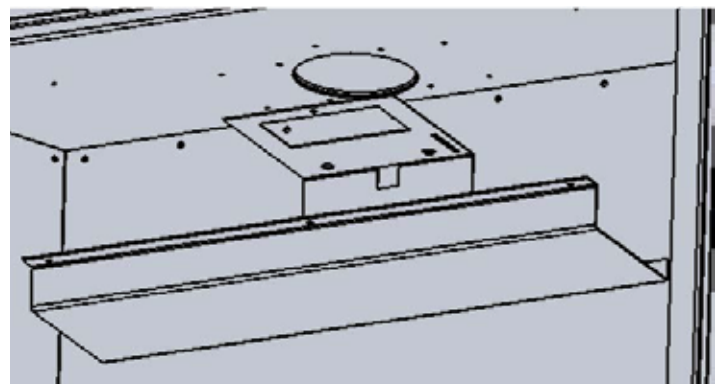

FLUEING ARRANGEMENTS - HORIZONTAL TERMINATIONS SIMPSON DURA-VENT DIRECT FLUE GS SYSTEM AND REGENCY® CO-AXIAL FLUE SYSTEM (FLEX) (PROPANE & NG)

The diagram below shows examples of horizontal termination arrangements using two 90° elbows (two 45° elbows equal one 90° elbow).

- Note:
- 1) A maximum of two 90° elbows are permitted.
 - 2) A minimum of 1.8m vertical from base of unit is required if two 90° elbows are used.
 - 3) Minimum distance between elbows is 0.6m.
 - 4) Determine the permitted range of horizontal termination arrangements by using chart in the "Simpson Dura-Vent Flueing" section and deducting 0.9m from the maximum horizontal distance for the second 90° elbow.

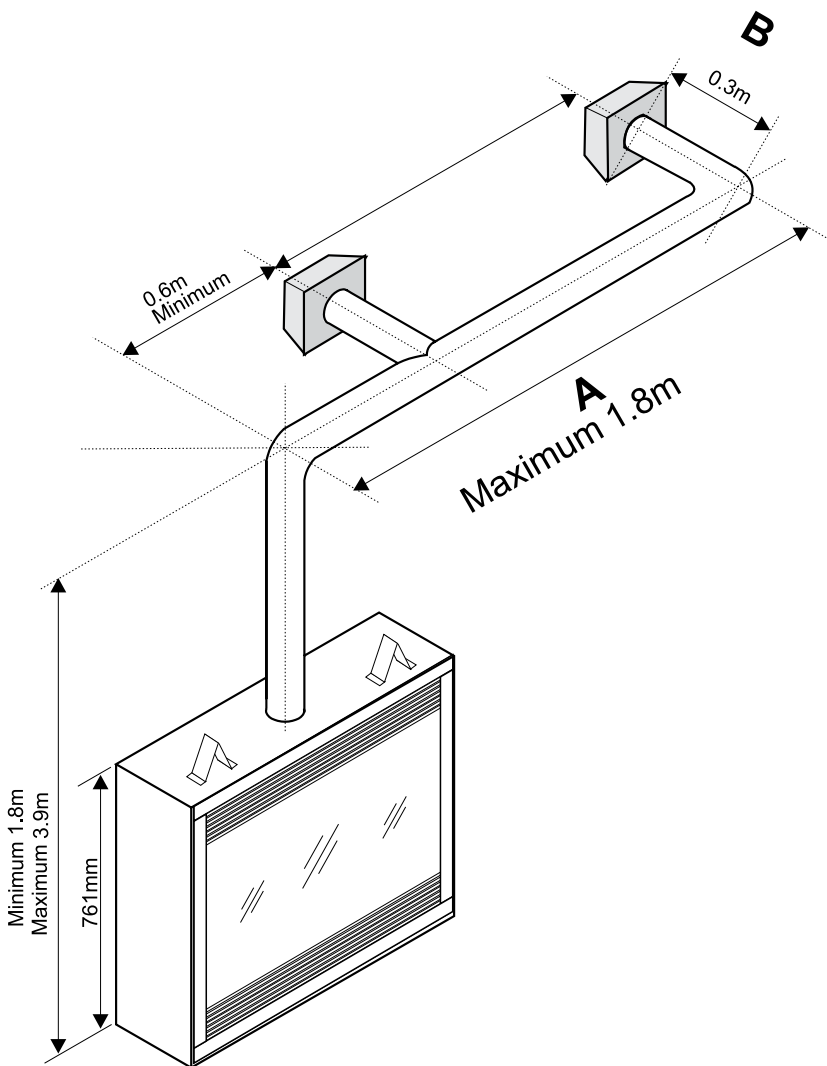

If length "B" is increased, length "A" must be decreased by a corresponding amount.

Simpson Dura-Vent
102mm inner diameter
168mm outer diameter

A flue guard should be used whenever the termination is lower than the specified minimum or as per local codes.

- Maintain clearances to combustibles as listed in the "Clearances," "Locating Your Gas Fireplace," "Combustible Mantels," "Mantel Leg Clearances" & "Framing and Finishing" sections.
- Horizontal flue must be supported every 0.9 meters.

FLUEING ARRANGEMENTS - VERTICAL TERMINATIONS SIMPSON DURA-VENT CO-AXIAL FLUE GS SYSTEM (PROPANE & NG)

The PG36 is approved for a 7.0m vertical, with a maximum 3.7m horizontal offset using two 90° elbows (two 45° elbows equal one 90° elbow) with **Simpson Dura-Vent Co Axial Flue GS** flue systems for Propane and NG, as per diagram 1.

The PG36 is approved for a 11.3m straight vertical, including a 0.5m horizontal offset using two 90° elbow (two 45° elbows equal one 90° elbow) with **Simpson Dura-Vent Co Axial Flue GS** flue systems for Propane and NG, as per the diagram 2.

- Flue must be supported at offsets
- Maintain clearances to combustibles as listed in the "Clearances," "Locating Your Gas Fireplace," "Combustible Mantels," "Mantel Leg Clearances" & "Framing and Finishing" sections.

Note: Must use optional flue adapter when using Simpson Dura-Vent pipe (Part # 510-994).

Note: Regency® Co Axial Flue System (Flex) is only approved for horizontal terminations.

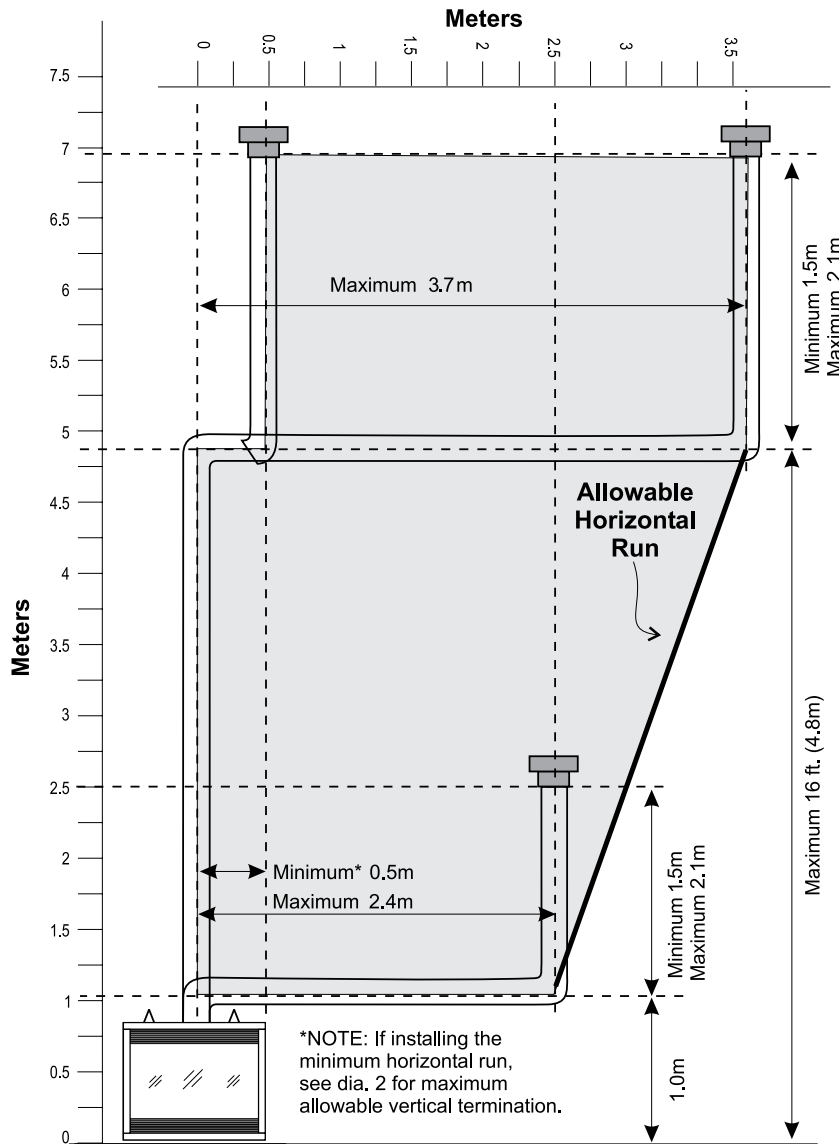

Diagram 1

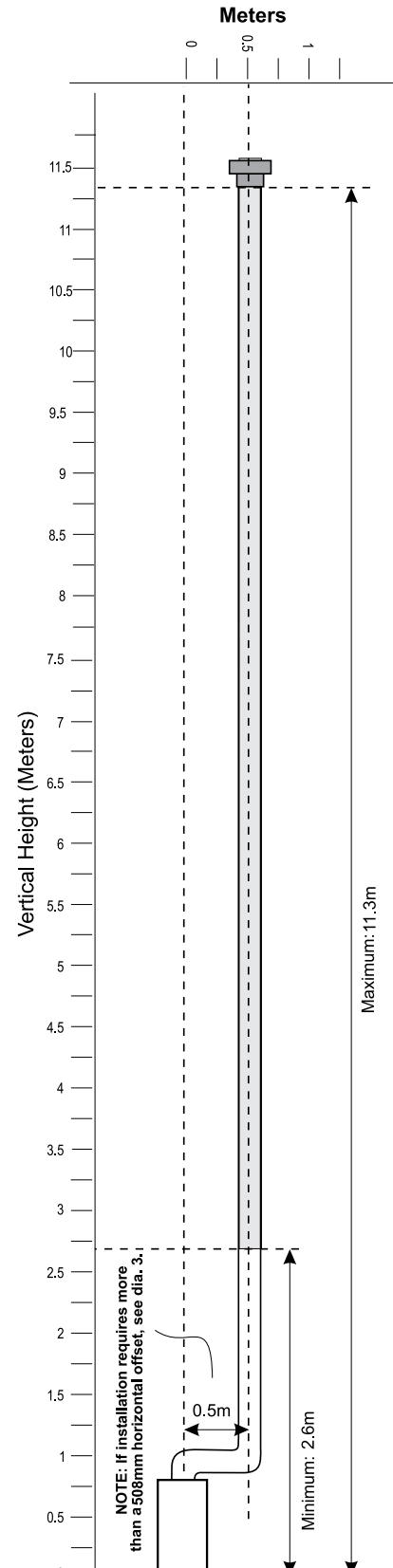
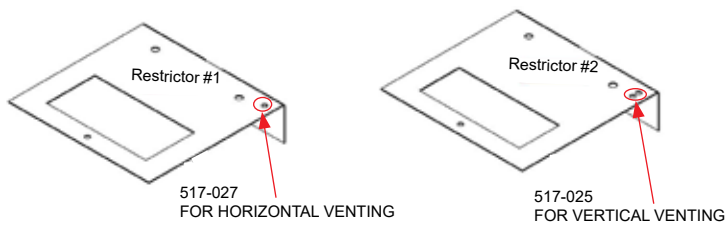

Diagram 2

The PG36 is approved for a 37 ft. (11.3 m) straight vertical, with **Simpson Dura-Vent Co Axial Flue GS** flue systems for Propane and NG, as per diagram 3.

The shaded area in diagram 3 shows all allowable combinations of straight vertical and offset to vertical terminations with **Simpson Dura-Vent Co Axial Flue GS** flue systems for Propane and NG. Maximum two 45° elbows allowed.

- The vent restrictor must be used in the shaded area. Vent restrictors are shown in images below.
- Flue must be supported at offsets
- Firestops are required at each floor level and whenever passing through a wall.
- Maintain clearances to combustibles as listed in the "Clearances," "Locating Your Gas Fireplace," "Combustible Mantels," "Mantel Leg Clearances" & "Framing and Finishing" sections.



VENT RESTRICTOR INSTALLATION

Check the vent diagrams to determine whether the vent restrictor is needed for your vent configuration.

The vent restrictor is packaged with the manuals inside the firebox.

If restrictor is required:

- 1) Remove the top louver.
- 2) Open and remove the glass door front.
- 3) Remove the internal baffle (3 screws) at the top of the firebox.
- 4) Place the restrictor on the baffle plate (see diagram below) and re-install the internal baffle plate.

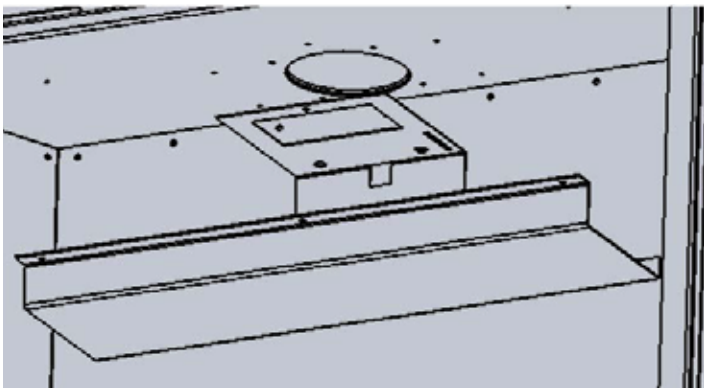

- 5) Replace the door and louvers.
- 6) Fire up the unit and check for proper flame appearance and glow on logs.

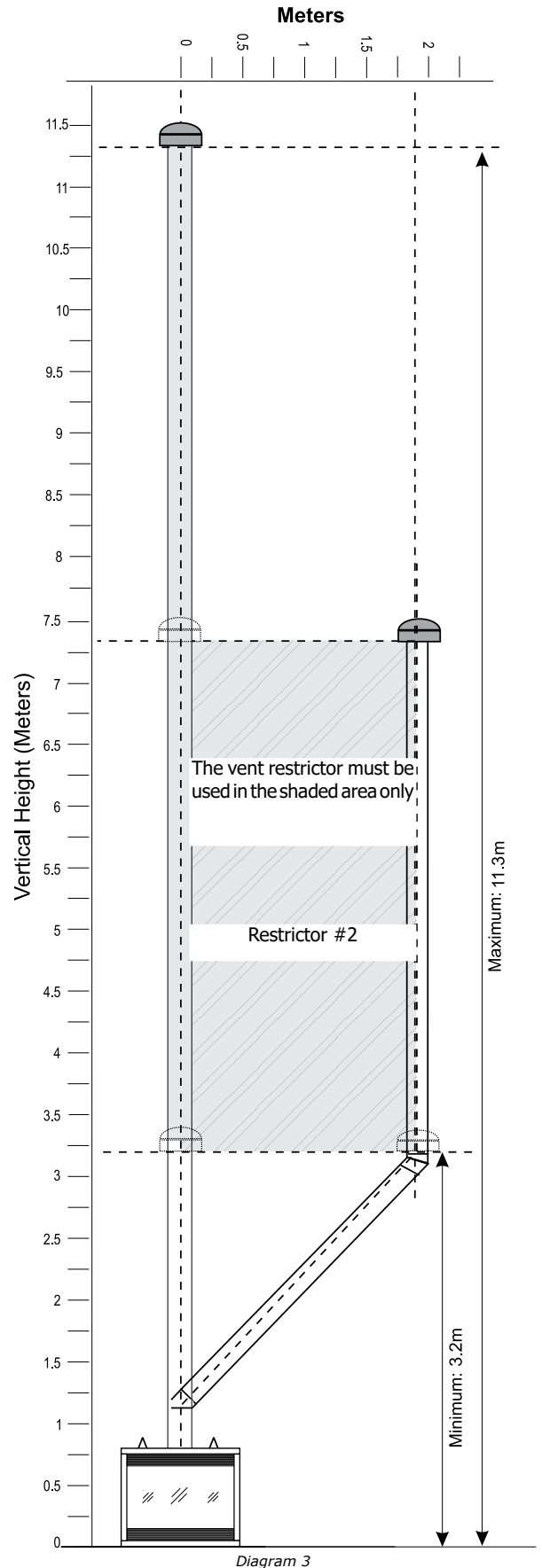
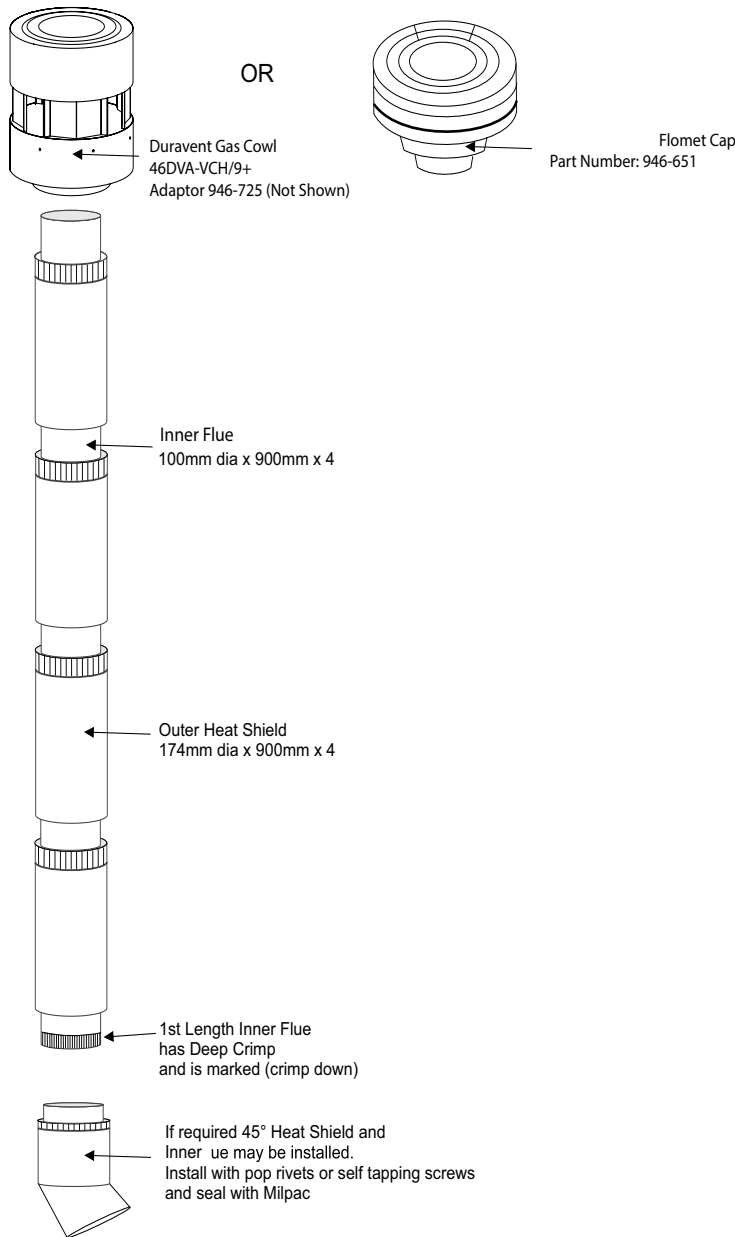

Diagram 3

DIRECT FLUE ZERO CLEARANCE TOP EXIT VERTICAL FLUE KIT INSTALLATION INSTRUCTIONS



This flue kit has been manufactured for use with PG36 and to be installed in accordance with AS/NZS 5601. To ensure safety and correct unit operation this flue kit must be installed as outlined in these instructions. Heater and flue clearances from combustible materials must be in accordance with these instructions and AS/NZS 5601.

1. Locate the heater in its proposed position and mark the point for penetration directly above the centre of the heater flue outlet. Check the heater location allows the outer flue to clear all structural timber and combustible surfaces as per the manual.
2. If the enclosure consists of a ceiling – cut a 240 mm square hole (minimum) for the flue to penetrate, cut hole through roofing material and prepare flashing for termination.
3. Starting at the heater, install first length of inner pipe, crimped end down, using Mill-Pac sealant and self-tapping screws (or rivets). Note – first length of inner pipe has a swage only.
4. Continue assembling flue pipes inner and outer, ensuring each inner joint is sealed using Mill-Pac sealant and self-tapping screws (or rivets). Outer flue pipe is to be installed with crimped end up then sealed and fixed together also.
5. If required, fix outer flue in the ceiling space using non-combustible bracing to stop movement. On penetration of roof, fit an appropriate flashing or weather seal to suit the roofing material, ensure all joints outside are sealed with appropriate sealer.
6. Fit gas cowl (46DVA-VCH/9) or flomet cap (946-651) ensuring inner and outer flue pipes are sealed.
7. Start heater and run for at least 15 minutes to check flue seal. If operational issues are noted, check flue again to ensure proper seal of inner pipe.

SUPPLIED **Mill-PAC SEALANT MUST BE USED OR WARRANTY WILL BE VOID** – IF REQUIRED, MORE SEALANT CAN BE PURCHASED USING PART NUMBER 948-128

Gas cowl part number 46DVA-VCH/9 or Flomet cap part number (946-651)

SCREWS SUPPLIED FOR INNER FLUE CONNECTION

45° bends (if required) part number 946-648 – **Note:** if bends are used at the start of flue run, a deeper crimp may be required at the unit for inner pipe fitment. Can be crimped on site and sealed with Mill-Pac sealant and self-tapping screws (or rivets).

Note: It is the installers responsibility to ensure the installation complies with AS/NZS 5601 and all local and building codes.

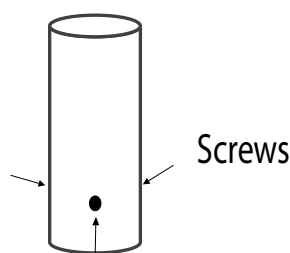
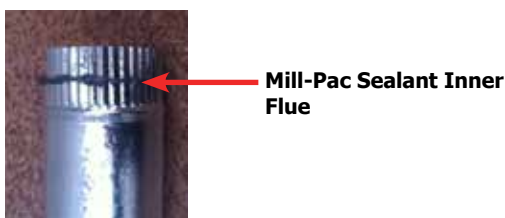

NOTE:
**USE A MINIMUM OF 3 SCREWS
EQUIDISTANT TO SECURE EVERY
INNER FLUE PIPE JOINT AS WELL
AS MILL-PAC SEALANT**