

## F5200 Large Stove

<b>Model</b>	<b>F5200</b>
Cordwood BTU's	80,000 BTU's
Emissions (grams/hr) EPA Certified	0.9 grams/hr
Efficiency (EPA LHV)	86%
Flue Size	*8" (203mm)
* Cannot be reduced in size	

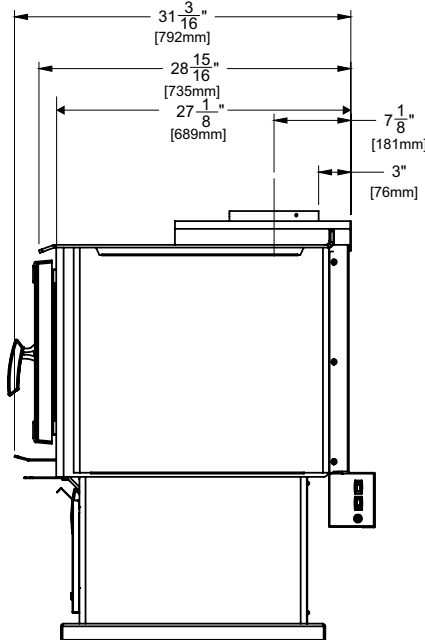

### Minimum Clearance To Combustible Materials

Measurements "From Unit" are from the top plate of the stove to a side wall or to a corner, and from the rear heat shield to a back wall.

Clearances may only be reduced by means approved by the regulatory authority.

**Note:** Minimum ceiling height roof exit - 83" (2108 mm)

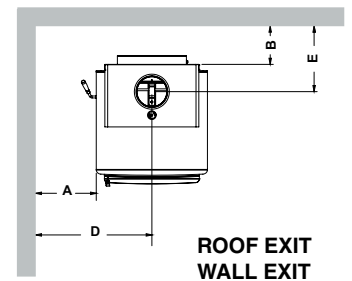
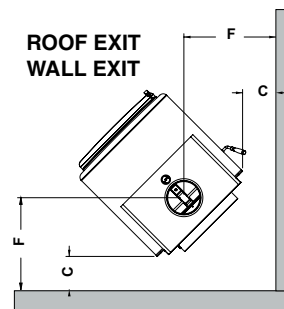
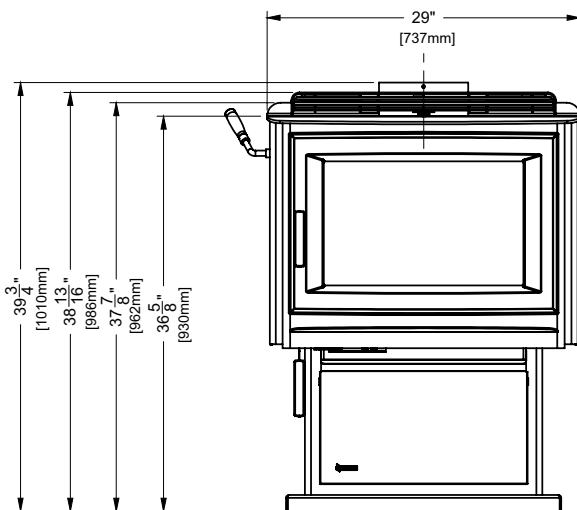

**Residential Close Clearance (To be installed with required pipe components) Listed Double Wall Pipe**  
When the stove is installed as a close clearance residential unit, a listed double wall connector is required from the stove collar to the ceiling level.

F5100	with Airmate or Rear Deflector	A	B	C	D	E	F
		11" 279mm	10" 254mm	8" 203mm	25-1/2" 648mm	17-1/8" 435mm	22-1/2" 572mm

## F5200 Wood Stove

<b>Mobile Home Close Clearance (To be installed with required pipe components) Listed Double Wall Pipe</b> When the stove is installed as a close clearance residential unit, a listed double wall connector is required from the stove collar to the ceiling level. Refer to Mobile Home Installation in the installation manual.							
F5200	with Airmate or Rear Deflector	A	B	C	D	E	F
		11" 279mm	10" 254mm	8" 203mm	25-1/2" 648mm	17-1/8" 435mm	22-1/2" 572mm

### Minimum Alcove Clearance to Combustible Materials

The Regency Freestanding models have been alcove approved and must be installed with a listed double wall connector to the ceiling level.

**Note:** Minimum alcove ceiling height - 83" (2108 mm) Vertical Termination  
**H = Maximum depth of alcove - 48" (1219mm)**  
**G = Minimum width of alcove - 63" (1600mm)**

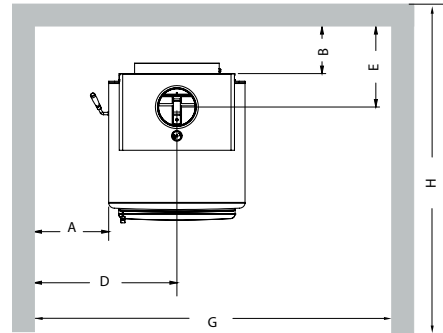

### FLOOR PROTECTION

A combustible floor must be protected by non-combustible material (like tile, concrete board, or certified to UL-1618 or as defined by local codes) extending beneath the heater and a minimum of 8" (203mm) from each side and minimum 16" (406mm) from the front face of the stove and minimum 6" (or the rear clearance to combustibles whichever is smaller) from the rear of the stove.

When installed with horizontal venting, non-combustible floor protection must beneath the flue pipe and extend 2" (51mm) beyond each side.

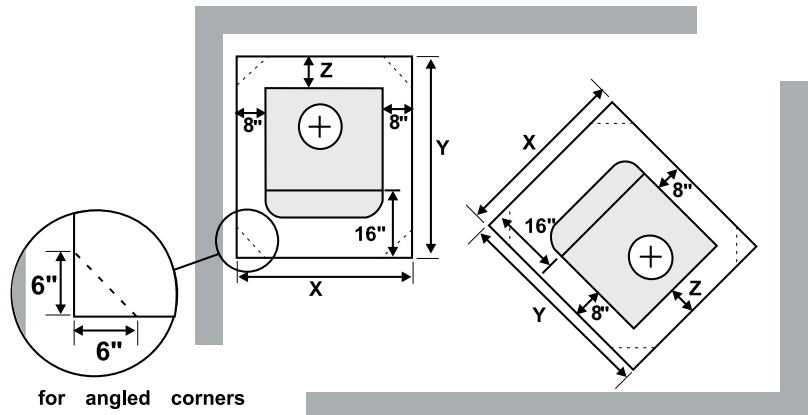

**Minimum Overall Width (X) of Floor Protector for all installations:**

Stove	F5200	45" (1143 mm)
-------	-------	---------------

**\* US measurements shown**

**NOTE: In Canada, floor protection must extend 18" (450mm) to the front and 8" (203mm) to each side and back of the stove.**

Minimum Overall Depth (Y) of Floor Protector						
Unit	Residential Close Clearance		Mobile Home Close Clearance		Alcove	
	Y	Z	Y	Z	Y	Z
F5200	Y	Z	Y	Z	Y	Z
USA	49-1/8"	8"	49-1/8"	8"	49-1/8"	8"
Canada	53-1/8"	8"	53-1/8"	8"	53-1/8"	8"

The rear clearance to combustibles is less than 6" (for corner installations the rear corners may be angled to take advantage of the closer clearances).