

U1500E-11 Gas Fireplace

Model	U1500E-NG11	U1500E-LP11
Fuel Type	Natural Gas	Propane
Minimum Supply Pressure	5" W.C. (1.25 kPa)	11" W.C. (2.73 kPa)
Manifold Pressure - High	3.5" W.C. (0.87 kPa)	10" W.C. (2.48 kPa)
Manifold Pressure - Low	1.6" W.C. (0.41 kPa)	6.4" W.C. (1.59 kPa)
Orifice Size - Altitude 0-4500 ft.	#30 DMS	#48 DMS
Minimum Input Altitude 0-4500 ft. (0-1372m)	29,000 BTU/h (8.49 kW)	33,500 BTU/h (9.82 kW)
Maximum Input Altitude 0-4500 ft. (0-1372m)	43,000 BTU/h (12.6 kW)	42,000 BTU/h (12.3 kW)
Vent Sizing	5" Inner / 8" Outer	5" Inner / 8" Outer
CSA P.4.1	67.46%	69.64%



Approved Venting Systems	
Flex Vent Systems:	FPI AstroCap™ Flex Vent
Rigid Pipe Vent Systems:	Simpson Direct Vent Pro® Selkirk Direct-Temp™ American Metal Products® Metal-Fab® Sure Seal Security Secure-vent® ICC Excel

Unit Dimensions with Faceplate

Unit Dimensions

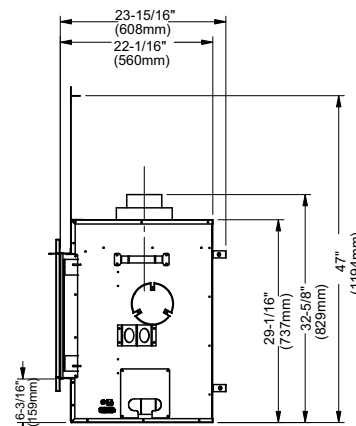
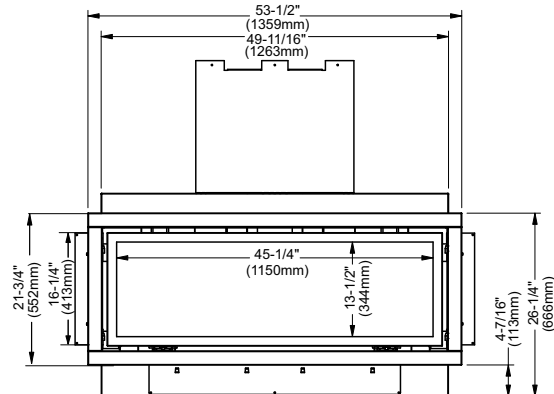
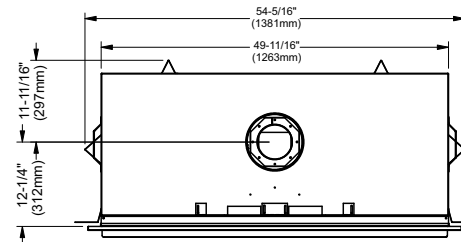
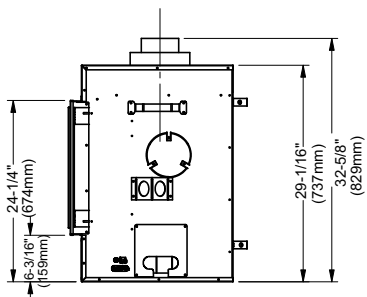
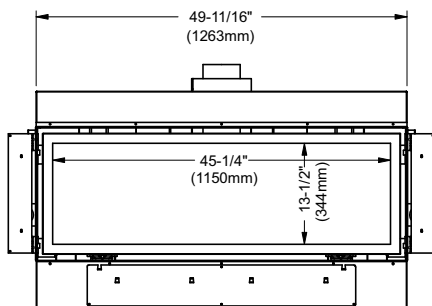
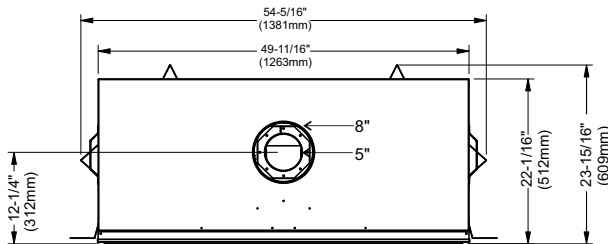

Glass Faceplate not shown
 Size : 57-1/2" Wide x 25-3/4" High
 Finishing Trim not shown
 (Clean Edge Design)
 Size: 50-11/16" Wide x 18-3/4" High

Framing Dimensions

Framing Dimensions	Description	U1500E
A	Framing Height	47" (1194mm)
B	Framing Width	55" (1397mm)
C*	Framing Depth	24-1/4" (615mm)
D	Minimum Height to Combustibles	69-1/2" (1765mm)
E	Corner Facing Wall Depth	65-3/4" (1670mm)
F	Corner Facing Wall Width	93" (2362mm)
G	Vent Centerline Height	41-3/8" (1051mm)
H	Non-combustible facing height	23-7/8" (606mm)
I	Gas Connection Opening Height	1-11/16" (43mm)
J	Gas Connection Height	2-11/16" (67mm)
K	Gas Connection Inset	1-1/8" (29mm)
L	Gas Connection Opening Width	4-11/16" (119mm)

* Framing depth measurement is noted with the nailing strips set as far forward on the firebox as possible. The nailing strips can be adjusted back up to 1-1/2" (38mm) to allow for varying thicknesses in non-combustible material & wall finishes. See non combustible section in the instruction manual for details.¹

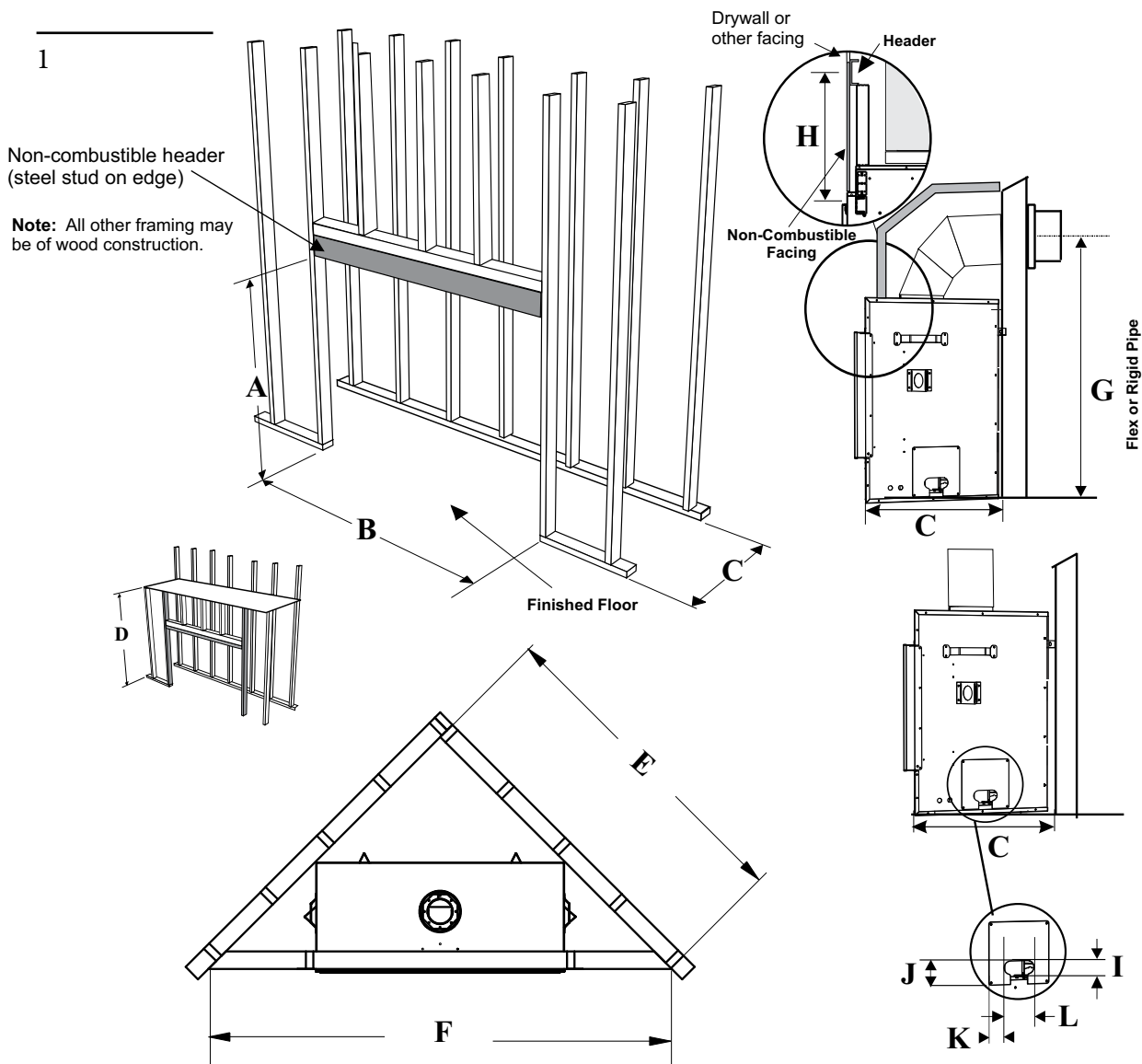

Clearances

The clearances listed below are minimum distances unless otherwise stated.

A major cause of chimney related fires is failure to maintain required clearances (air space) to combustible materials. It is of the greatest importance that this fireplace and vent system be installed only in accordance with these instructions.

Clearance:	Dimension	Measured From:
A: Mantel Height (min.)	25" (635mm)	Top of Fireplace Opening
B: Sidewall (on one side)	6" (152mm)	Side of Fireplace Opening
C: Ceiling (room and/or alcove)	46-1/4" (1175mm)	Top of Fireplace Opening
D: Mantel Depth (max.)	12" (305mm)	34" (864mm) Above Fireplace Opening
E: Alcove Width	60" (1524mm)	Sidewall to Sidewall (Minimum)
F: Alcove Depth	36" (914mm)	Front to Back Wall (Maximum)
G: From Floor	24-1/4" (616mm)	Top of Fireplace Opening
Note:	0"	No hearth required

Flue Pipe Clearances to Combustibles	
Horizontal - Top	3"
Horizontal - Side	2"
Horizontal - Bottom	2"
Vertical	2"
Passing through wall/floor/ceiling - when firestop is used.	1-1/2"



The **HeatWave** Duct Kit has different clearance and framing requirements, check the **HeatWave** manual for details.

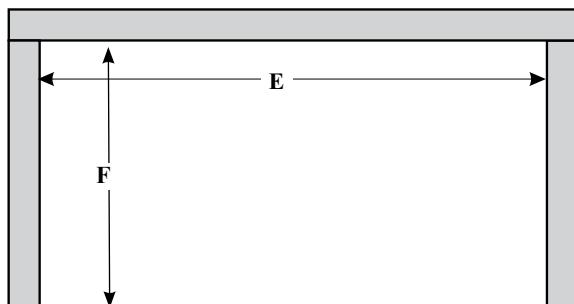
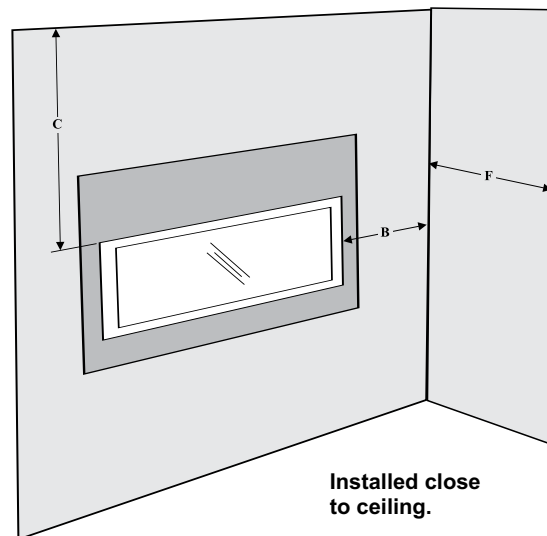
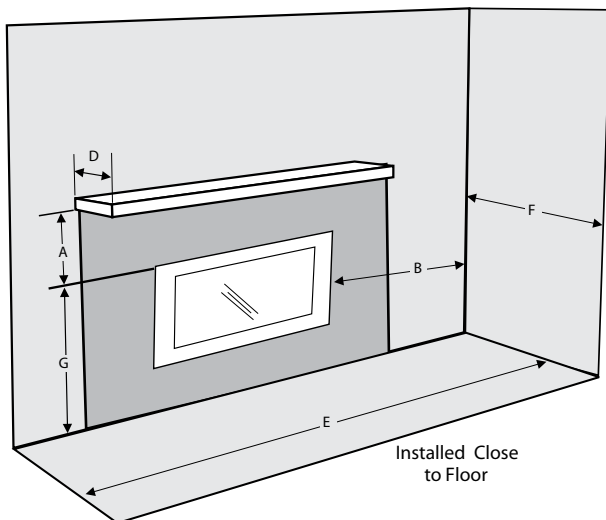

Alcove

Caution Requirements

The top, back and sides of the fireplace are defined by standoffs. The metal ends of the standoff may **NOT** be recessed into combustible construction.

WARNING

Fire hazard is an extreme risk if these clearances (air space) to combustible materials are not adhered to. It is of greatest importance that this fireplace and vent system be installed only in accordance with these instructions.

Mantel Clearances

Due to the extreme heat this fireplace emits, the mantel clearances are critical. Combustible mantel clearances from top of front facing are shown in the diagram on the right.

Note: Ensure the paint that is used on the mantel and the facing is "high quality" or the paint may discolour.

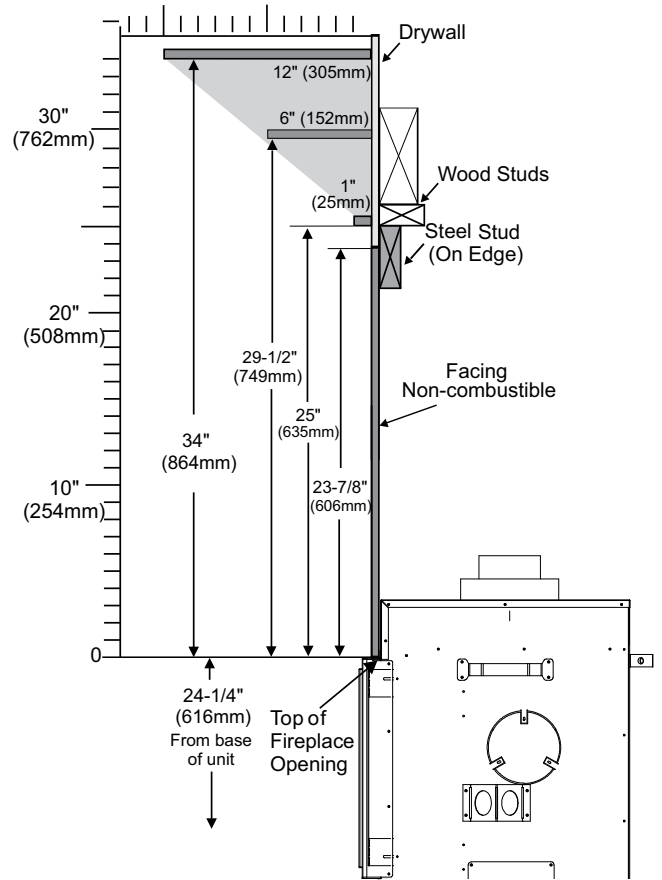

Mantel Leg Clearances

Combustible mantel leg clearances as per diagram:

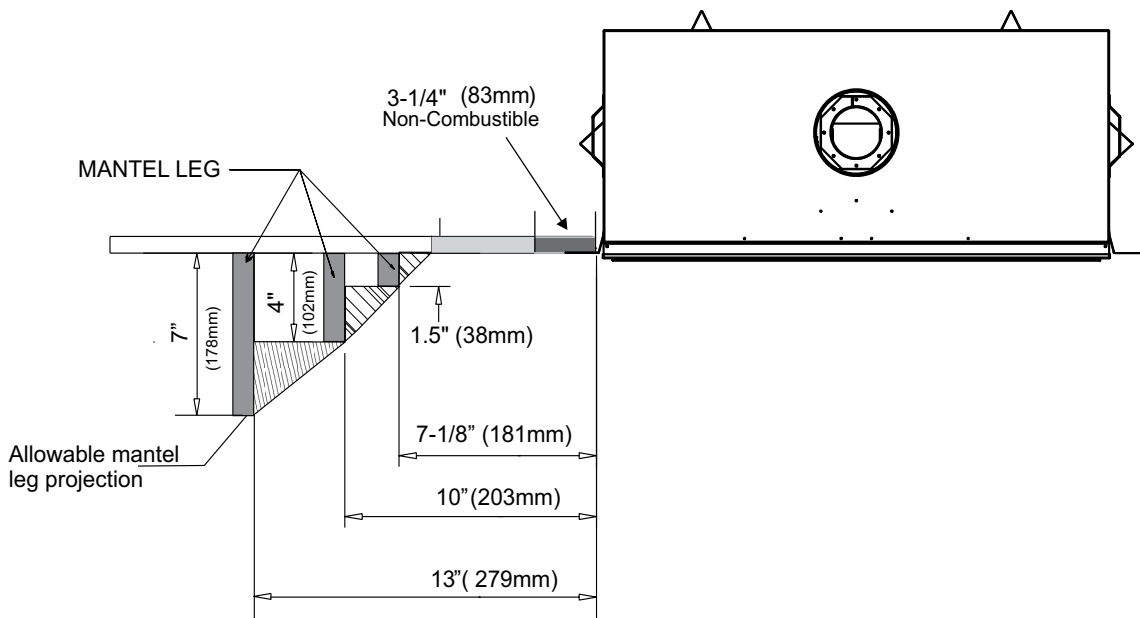

Non-Combustible Requirements

* Installation of the ON/OFF Wall Switch/Battery Holder must be completed before installing non-combustible facing.

All three pieces (top, 2 sides) are supplied to meet the non combustibility requirements.

Calcium silicate board is a high - grade material with cement, quartz, natural and selected minerals as the main raw materials. It is widely used for partitions and ceilings in buildings. It is fire proof and earthquake proof.

If finishing the wall above the unit with materials such as tile, brick, marble, etc. non-combustible board available from the building supply store can be used.

Note: Calcium Silicate is 1/2" thick

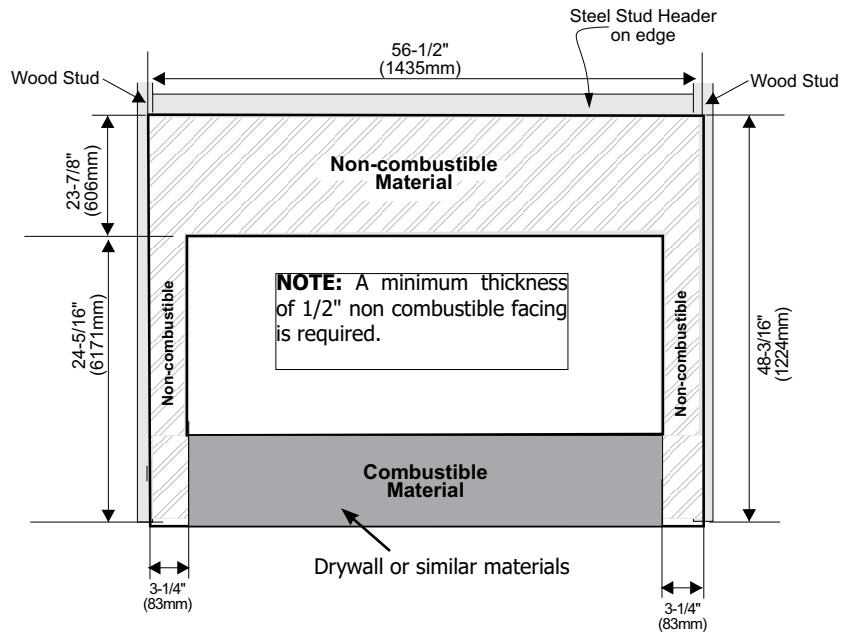

Non-Combustible Facing Installation

Caution: The non-combustible board can be damaged if dropped or struck. **Handle with care.**

1. Using drywall screws - secure non combustibility material around unit, framing and top nailing strip every 6 inches.

Important Note: To avoid cracking the board - pre-drill holes prior to securing to unit/ framing.

2. Wipe any debris/dust from the non combustibility material and drywall.
3. Prior to securing it is mandatory to prime the facing and edges using a quality primer. This will ensure proper adhesion of both the tape and mud. The supplied board is very porous. Failure to follow this procedure will result in cracked seams.
4. Tape the seams using a mesh type tape.
5. Mud seams as normal. We recommend using a product called Durabond high strength compound - for the first coat. This product can be found most hardware stores. Mud must be cured as per manufacturer's recommendations.
6. Prime wall for a second time for proper adhesion of paint
7. Paint walls using a high quality paint which will withstand the high temperatures being emitted from this appliance.

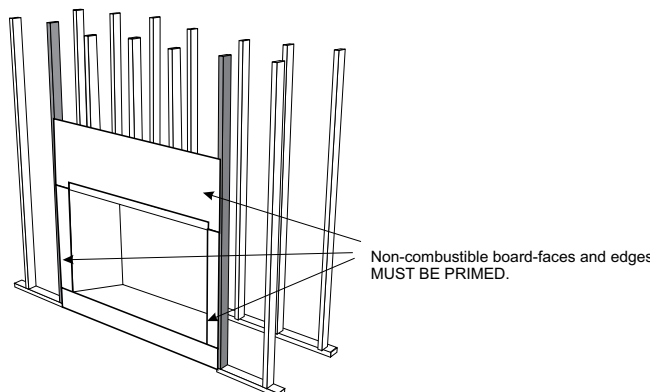
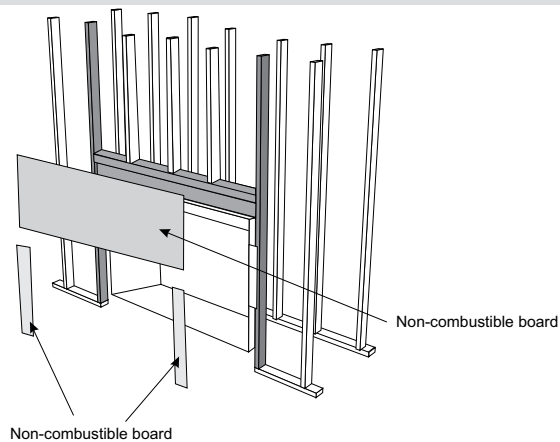

Framing & Finishing

1. Frame in the enclosure for the unit with framing material.

IMPORTANT: The framed opening must be of non-combustible material.

Note: When constructing the framed opening, please ensure there is access to install the gas lines when the unit is installed.

2. For exterior walls, insulate the enclosure to the same degree as the rest of the house, apply vapour barrier and drywall, as per local installation codes. **(Do not insulate the fireplace itself and/or the venting. Clearances must be maintained as per this manual.)**

WARNING: Failure to insulate and add vapor barriers to the inside of the exterior wall will result in operational and performance problems including, but not limited to: excessive condensation on glass doors, poor flame package, carbon, blue flames etc. These are not product related issues.

3. The unit does not have to be completely enclosed in a chase. You must maintain clearances from the vent to combustible materials: See "Clearances" section. Combustible materials can be laid against the side and back standoffs and the stove base.
4. Non-combustible material (ie. tile, slate, etc) may be brought up to and overlap the unit (top and bottom) ensuring that the maximum thickness does not go beyond the 1-1/2" as shown in the diagram below. The faceplate will not be able to be mounted if finished material is beyond 1-1/2".

5. If material such as brick, stone, etc extends past the faceplate depth 1-1/2", when finishing around the faceplate, the minimum opening dimensions noted below must be adhered to ensuring for the removal of the faceplate and for the safe operation of this appliance.

NOTE: Spacing of 1" around the completed surround must be adhered to.

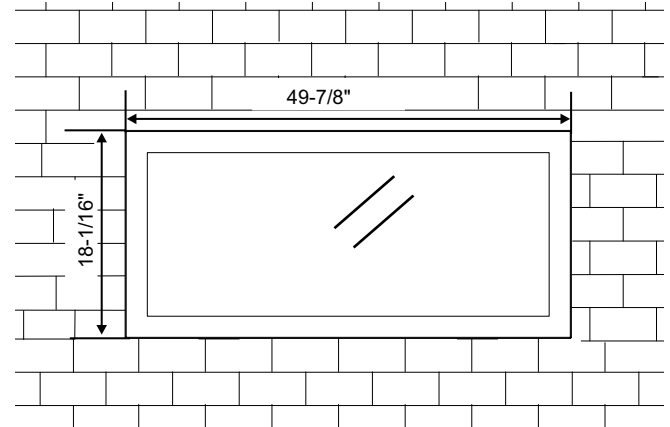

*Unit shown with inner door frame only
Using the clean edge of the unit shown
in a typical tiled facing.*

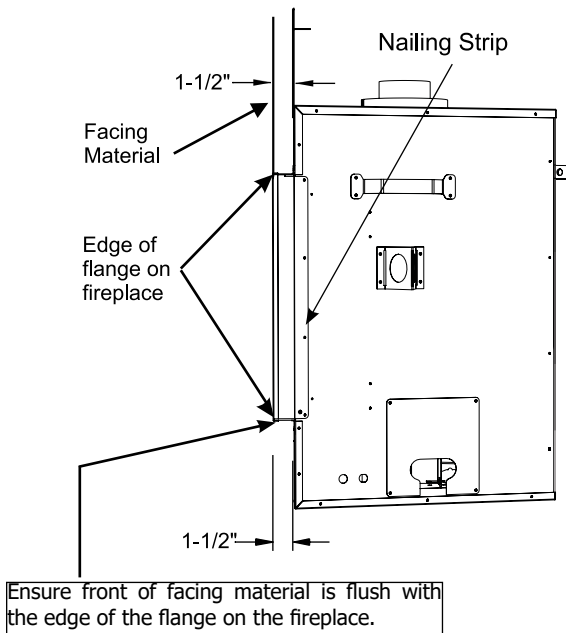

Framing & Finishing

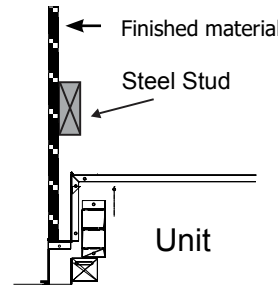
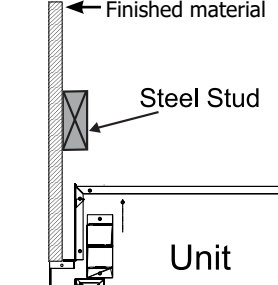
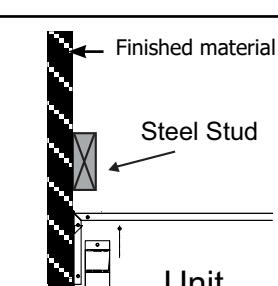
Finished Material	Nailing Strip Position	
1/2" (13mm)	1" (25mm)	
1" (25mm)	1/2" (13mm)	
1-1/2" (38mm)	0" (flush)	

Important:

Determine the nailing strip position by determining the facing material being used.

Examples:

1/2" non-combustible wall board for clean finish = 1" adjustment.

1/2" non-combustible wall board + 1/2" tile = 1" of finished material = 1/2" adjustment.

Note:

Depending on the material used for finishing, the nailing strips must be set accordingly so that the finished material is always at the 1-1/2" edge of the flange.

Note : If material such as brick, stone, etc extends past the depth of 1-1/2" when finishing around the faceplate (Inner/Outer faceplate/Verona glass surround), the minimum opening dimensions around the faceplate must be adhered to ensuring for the removal of the faceplate and for the safe operation of this appliance. See framing and finishing in this manual for details.

If only using the inner door trim to create a clean edge finish on all 4 sides, non combustible material may extend beyond the 1 1/2" face to give you a recessed look.

If the material below the appliance which only requires combustible material extends beyond the 1 1/2" lip, (ie: a hearth in front of the appliance) non combustible material must be used. Combustible material cannot extend beyond the bottom lip of the fireplace.

If using the finishing trim for clean face design, the maximum allowable depth is 1 1/2". The finishing trim will not fit if it exceeds 1 1/2".

IMPORTANT

Regency Fireplace Products are designed, produced, tested and certified to the highest industry standards.

The finishing of the walls surrounding your Regency Horizon Fireplace is as critical as the installation itself.

The temperatures around linear gas fireplaces are typically higher than would be acceptable for combustible materials. Your Regency Horizon Fireplace is no exception to this rule. Therefore, the units are specified with non-combustible required materials to specific dimensions above and around the units. This is due to these areas reaching higher temperature levels than required/acceptable for a combustible material. To obtain the best, most durable finish around your fireplace, this calls for a high level of care and attention to the preparation and finish around this appliance, using only the highest quality materials, able to withstand the temperatures produced. By following the installation instructions in the manual exactly, you will increase your chances of a damage free finish.

While every precaution is taken in providing the recommendations on preparation and finish, given the variations in paint quality, with temperature limits and workmanship in application, Regency is unable to guarantee the life of the joint compounds, paint or any other finish materials or workmanship applied to or used in any application surrounding the fireplace. This includes framing as well as finishing. Over time natural convection from any fireplace can cause discoloration in the area directly above the appliance. Lower quality paints, under-prepared finishes, poor applications, and any framing discrepancies or in the installation can cause this discoloration process to be expedited.

Discoloration is not the responsibility of Regency Fireplace Products. This is out of the control of Regency Fireplace Products Ltd., therefore not covered under any part of the warranty policy.

While discoloration is not the responsibility of Regency Fireplace Products, we believe careful attention to the recommendations provided here will result in an aesthetically pleasing result free of issues outlined above.

Optional Framing Kit

1. Construct the timber framing, ensure inside dimensions are 48-5/8" H x 55" W as shown below.

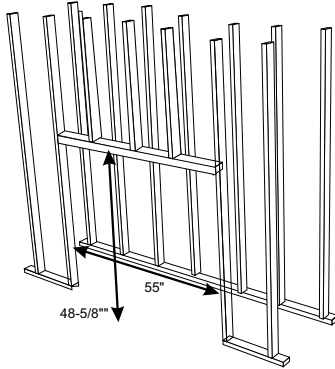

2. Bend both side nailing strips from the side of the appliance until positioned as shown below.
Determine the overall combined thickness of the non-combustible board + finished material being used. The nailing strips can be adjusted up to 1-1/2".
Remove top nailing strip (by removing 3 screws) and recycle.

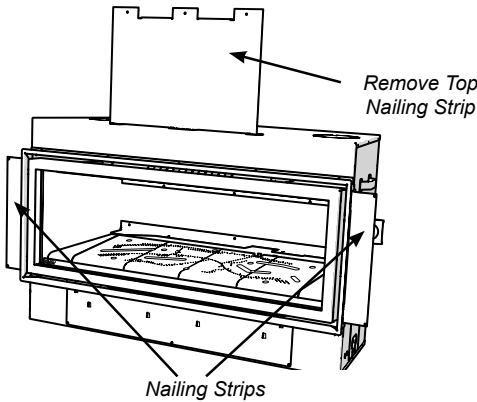

3. Adjust the nailing strips by loosening 2 screws on each nailing strip - adjust and retighten screws.
4. Attach both vertical studs (676-036)A to the vertical timber studs and secure using 6 screws (2 at bottom, 2 at top and 2 on sides) as shown.

NOTE: Ensure the flat side of the steel stud is facing the wood framing.

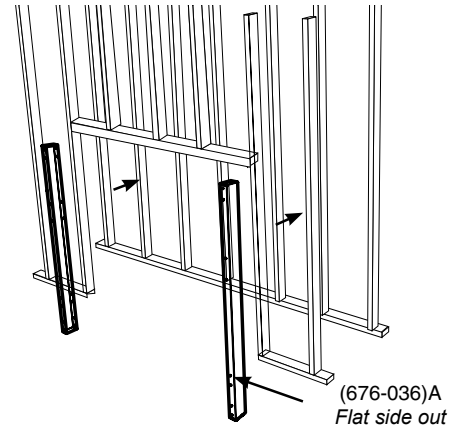
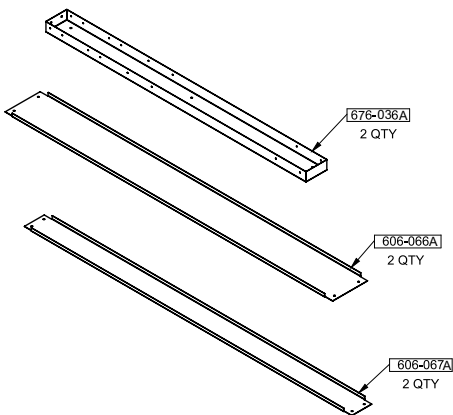

5. Secure horizontal steel header stud (606-067) with 2 screws per side as per diagram.

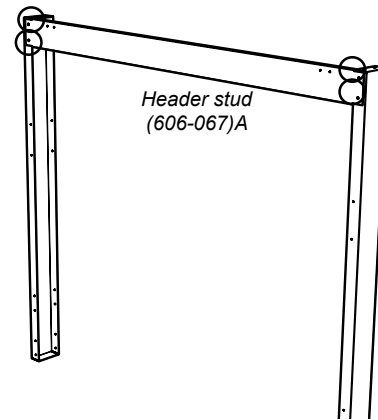

6. Slide the unit into position. Hook up gas, venting, electrical and conversion kit (if purchased) prior to installing the remaining steel studs.
7. Secure the upper horizontal steel studs as shown with 2 screws per side.
8. Secure the 2 remaining large horizontal studs (606-066)A with 2 screws per side as shown.

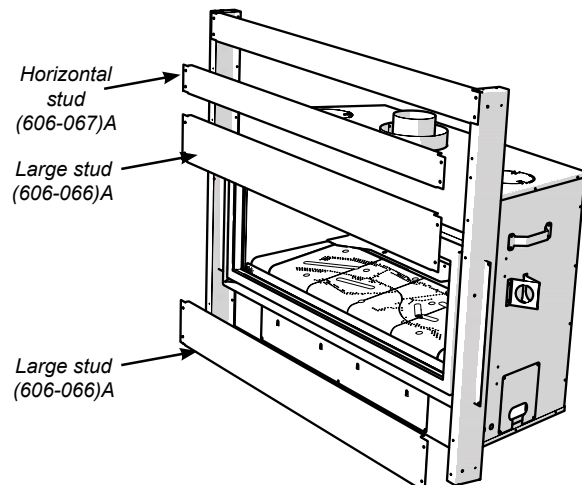

Venting Introduction

The U1500E uses the "balanced flue" technology Co-Axial system. The inner liner vents products of combustion to the outside while the outer liner draws outside combustion air into the combustion chamber thereby eliminating the need to use heated room air for combustion and losing warm room air up the chimney.

Note: These flue pipes must not be connected to any other appliance.

The gas appliance and vent system must be vented directly to the outside of the building, and never be attached to a chimney serving a separate solid fuel or gas burning appliance. Each direct vent gas appliance must use its own separate vent system. Common vent systems are prohibited.

Venting Arrangement for Horizontal Terminations

The diagram shows all allowable combinations of vertical runs with horizontal terminations, using one 90° (two 45° elbows equal one 90° elbow).

Note: Must use optional rigid pipe adapter (Part# 770-994) when using Rigid Pipe Venting Systems.

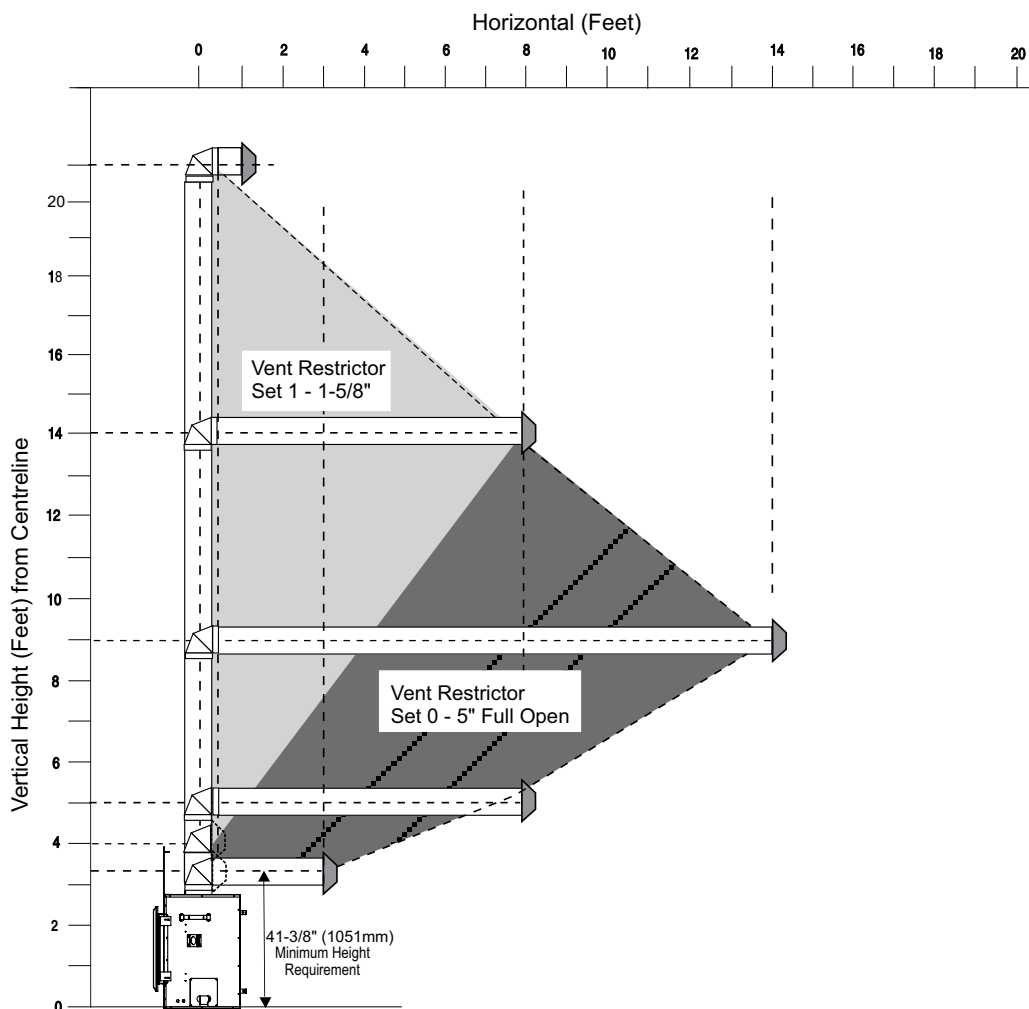

VENT RESTRICTOR SETTING:

Vent restrictor factory set at Set 0.

Refer to the "Vent Restrictor Position" section for details on how to change the vent restrictor from the factory setting of Set 0 to Set 1 if required.

Note: For horizontal terminations the Regency Direct Vent Flex System may be used for installations with a maximum continuous vent length of up to 10 feet. If longer runs are required, rigid pipe must be used.

- Maintain clearances to combustibles as listed in "Clearances" section
- Horizontal vent must be supported every 3 feet.
- Firestops are required at each floor level and whenever passing through a wall.
- A vent guard should be used whenever the termination is lower than the specified minimum or as per local codes.

Venting Arrangement for Vertical Terminations

Vertical Venting with One(1) 90° Elbows (1 - 90° = 2 - 45°) with straight Vertical and or a maximum offset using 2 - 90° elbows

The shaded area in the diagram shows all allowable combinations of straight vertical and offset to vertical terminations, using one 90° elbow, with Rigid Pipe Venting Systems.

Two 45° elbows equal to one 90° elbow.

- Vent must be supported at offsets.
- Minimum distance between elbows is 1 ft. (305mm).
- Maintain clearances to combustibles as listed in the "Clearances" section.
- Horizontal vent must be supported every 3 feet.
- Firestops are required at each floor level and whenever passing through a wall.
- Must use optional rigid pipe adaptor (Part# 510-994. when using rigid pipe vent systems.
- Refer to the "Vent Restrictor Position" section for details on how to change the vent restrictor from the factory setting of Set 0 to Set 1 or Set 2 if required.

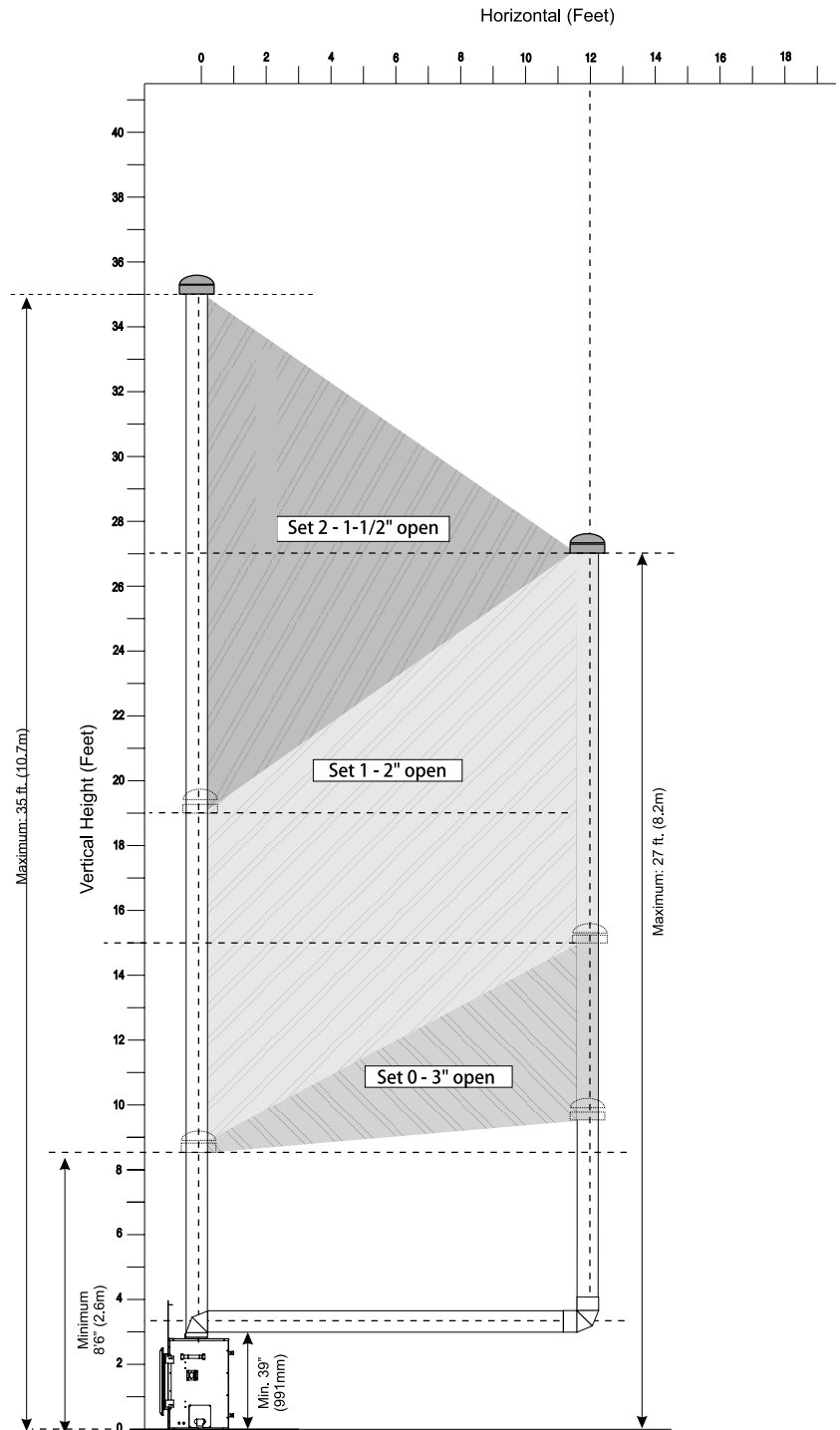

Vertical Venting with Three (3) 90° Elbows

One 90° elbow = Two 45° elbows.

Option	V	H + H1	V + V1	
A)	0' Min.	2' Max.	2' Min.	With these options, max. total pipe length is 30 feet with min. of 10 feet total vertical and max. 8 feet total horizontal. Please note min. 1 foot between 90° elbows is required.
B)	1' Min.	2' Max.	3' Min.	
C)	2' Min.	3' Max.	4' Min.	
D)	3' Min.	4' Max.	6' Min.	
E)	4' Min.	5' Max.	7' Min.	
F)	5' Min.	6' Max.	8' Min.	
G)	6' Min.	7' Max.	9' Min.	
H)	7' Min.	8' Max.	10' Min.	
Restrictor Set 0 - 5" Factory Setting				

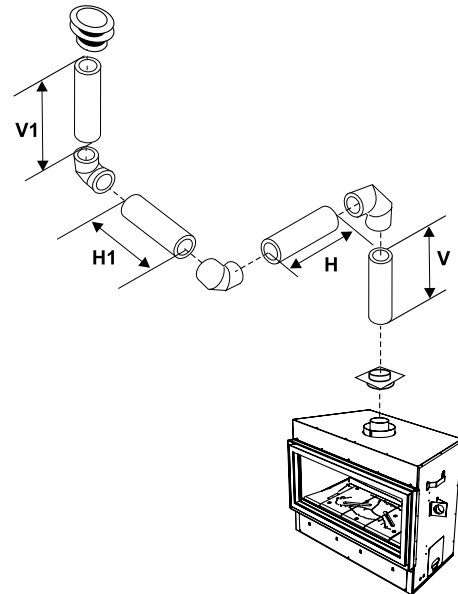

Horizontal Venting with Two (2) 90° Elbows

One 90° elbow = Two 45° elbows.

Option	V	H + H1	
A)	1' Min.	3' Max.	With these options, maximum total pipe length is 30 feet with minimum of 6 feet total vertical and maximum 8 feet total horizontal. Please note minimum 1 foot between 90° elbows is required.
B)	2' Min.	4' Max.	
C)	3' Min.	5' Max.	
D)	4' Min.	6' Max.	
E)	5' Min.	7' Max.	
F)	6' Min.	8' Max.	
Restrictor Set 0 - 5" Factory Setting			

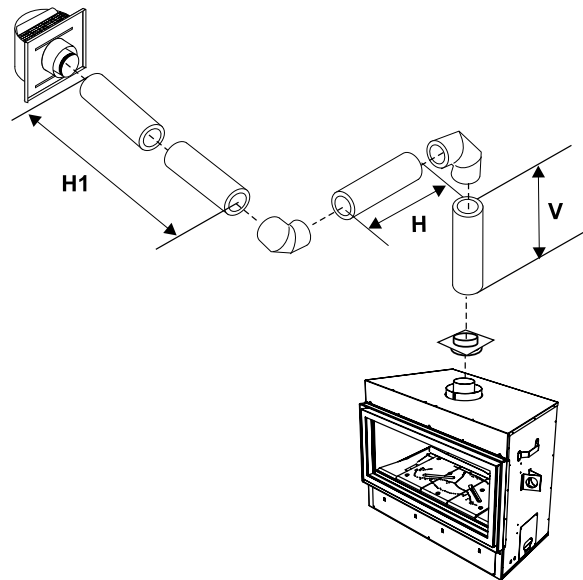

Horizontal Venting with Three (3) 90° Elbows

One 90° elbow = Two 45° elbows.

Option	V	H	V + V1	H + H1	
A)	0' Min.	1' Max.	1' Min.	2' Max.	With these options, max. total pipe length is 30 feet with min. of 12 feet total vertical and max. 9 feet total horizontal. Please note min. 1 foot between 90° elbows is required.
B)	1' Min.	2' Max.	3' Min.	3' Max.	
C)	2' Min.	2' Max.	5' Min.	4' Max.	
D)	3' Min.	2' Max.	7' Min.	5' Max.	
E)	4' Min.	3' Max.	9' Min.	6' Max.	
F)	5' Min.	4' Max.	10' Min.	7' Max.	
G)	6' Min.	5' Max.	11' Min.	8' Max.	
H)	7' Min.	6' Max.	12' Min.	9' Max.	
Restrictor Set 0 - 5" Factory Setting					

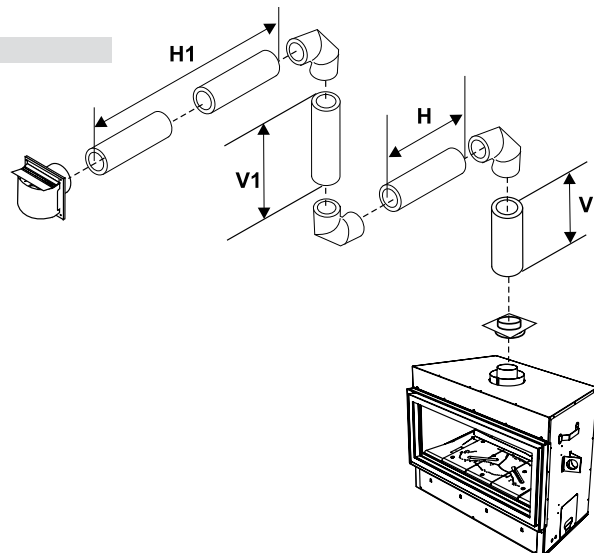

Horizontal Termination - 5" x 8" Venting (Rigid Vent Systems)

Minimum Vent Clearances to Combustibles

* Clearances noted below must be maintained; except when passing through a wall, ceiling or at the termination where the use of a firestop or wall thimble reduces clearance to 1-1/2" (38mm).

Horizontal Top*	3" (76mm)*
Horizontal Side	2" (51mm)
Horizontal Bottom	2" (51mm)
Vertical Vent	2" (51mm)

Below are the recommended framing dimensions (inside measurements) for the 5" x 8" rigid vent terminations - for use with a firestop or wall thimble.

Install the vent system according to the manufacturer's instructions included with the components.

1. Set the unit in its desired location. Check to determine if wall studs or roof rafters are in the way when the venting system is attached. If this is the case, you may want to adjust the location of the unit. Rough in the gas preferably on the right side of the unit and the electrical (junction block is on the left side) on the left.
2. Direct Vent pipe and fittings are designed with special twist-lock connections to connect the venting system to the appliance flue outlet. A twist-lock appliance adaptor is required.
3. In conjunction with the Approved Vent system, install the adaptor after the unit is set in its desired location. Slip the adapter over the existing inner and outer flue collar. Fasten to the outer collar only with the 3 supplied screws (drilling pilot holes will make this easier).
4. Level the fireplace and fasten it to the framing using nails or screws through the top and side nailing strips.

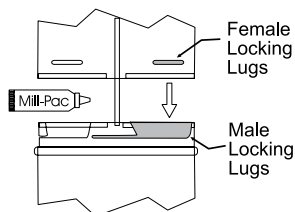

Diagram 1

5. Assemble the desired combination of pipe and elbows to the appliance adaptor and twist-lock for a solid connection.

Note: For best results and optimum performance with each approved venting system, it is highly recommended to apply "Mill-Pac" sealant (supplied) to every inner pipe connection. Failure to do so may result in drafting or performance issues not covered under warranty.

Horizontal runs of vent must be supported every 3 feet (0.9meter). Wall straps are available for this purpose.

6. Mark the wall for a square hole.-see chart to left for size. The center of the square hole should line up with the center-line of the horizontal pipe. Cut and frame the square hole in the exterior wall where the vent will be terminated. See diagram 54 for center line requirements.

If the wall being penetrated is constructed of non-combustible material, i.e. masonry block or concrete, an 8" (203mm) diameter hole is acceptable.

Notes:

- a) The horizontal run of vent must be level, or have a 1/4 inch rise for every 1 foot of run towards the termination. Never allow the vent to run downward. This could cause high temperatures and may present the possibility of a fire.
- b) The location of the horizontal vent termination on an exterior wall must meet all local and national building codes, and must not be blocked or obstructed. See "Exterior Vent Termination Locations" section for more details.

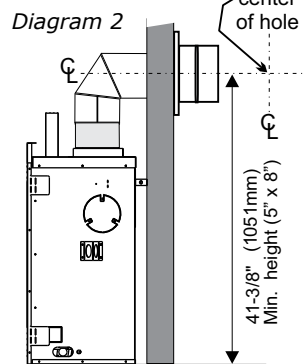

IMPORTANT
Must use Rear Venting Deflector packaged with unit in rear vent horizontal termination applications.

c) Snorkel Terminations:

For installations requiring a vertical rise on the exterior of the building, 14-inch and 36-inch tall Snorkel Terminations are available, as well as the standard Riser Vent. Follow the same installation procedures as used for standard Horizontal Termination. NEVER install the snorkel upside down.

Diagram 3

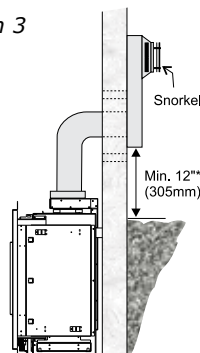

*As specified in CSA B149.1 Installation Code. Local codes or regulations may require different clearances.

Below Grade Snorkel Installation

If the snorkel termination must be installed below grade, i.e. basement application, proper drainage must be provided to prevent water from entering the snorkel termination. See diagram 56. Do not attempt to enclose the snorkel within the wall or any other type of enclosure.

Diagram 4

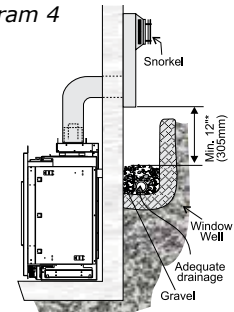

7. Ensure that the pipe clearances to combustible materials are maintained (Diagram 55). Install the termination cap.

Note: If installing termination on a vinyl siding covered wall, a vinyl siding standoff or furring strips must be used to ensure that the

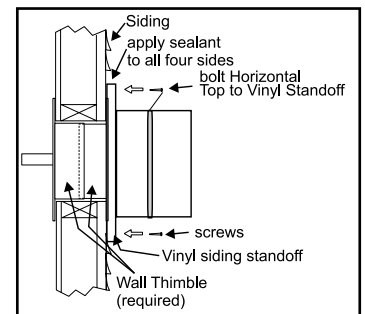

termination is not recessed into the siding.

The four wood screws provided should be replaced with appropriate fasteners for stucco, brick, concrete, or other types of sidings.

8. Before connecting the horizontal run of vent pipe to the vent termination, slide the Wall Thimble over the vent pipe. The wall thimble is required for all horizontal terminations.
9. Slide the appliance and vent assembly towards the wall carefully inserting the vent pipe into the vent cap assembly. It is important that the vent pipe extends into the vent cap sufficient distance so as to result in a minimum pipe overlap of 1-1/4 inches (32mm). Secure the connection between the vent pipe and the vent cap.
10. Install wall thimble in the center of the framed hole and attach with wood screws.

