

H15 Direct Vent Gas Fireplace

Owners &
Installation Manual



www.hampton-fire.com

MODELS: H15-NG1 Natural Gas H15-LP1 Propane

<p>WARNING: If the information in these instructions are not followed exactly, a fire or explosion may result causing property damage, personal injury or loss of life.</p>	<p>FOR YOUR SAFETY</p> <p>What to do if you smell gas:</p> <ul style="list-style-type: none"> ● Do not try to light any appliance ● Do not touch any electrical switch: do not use any phone in your building. ● Immediately call your gas supplier from a neighbour's phone. Follow the gas supplier's instructions. ● If you cannot reach your gas supplier, call the fire department. 	<p>This appliance may only be installed in an aftermarket permanently located, manufactured (USA only) or mobile home, where not prohibited by local codes.</p>
<p>FOR YOUR SAFETY Do not store or use gasoline or other flammable vapours and liquids in the vicinity of this or any other appliance.</p>		<p>This appliance is only for use with the type of gas indicated on the rating plate. This appliance is not convertible for use with other gases, unless a certified kit is used.</p>
<p>Installation and service must be performed by a qualified installer, service agency or the gas supplier.</p>		



Installer: Please complete the details on the back cover and leave this manual with the homeowner.
Homeowner: Please keep these instructions for future reference.



H15 Product Video

HAMPTON®
Direct Vent Freestanding Gas Stove
To the New Owner:

Congratulations!

You are the owner of a state-of-the-art Hampton® Gas Stove by FPI FIREPLACE PRODUCTS INTERNATIONAL LTD. The H15-1 is a hand crafted appliance and has been designed to provide you with all the warmth and charm of a wood fireplace at the flick of a switch. The model H15-1 has been approved by Warnock Hersey for both safety and efficiency. As it also bears our own mark, it promises to provide you with economy, comfort and security for many trouble free years to follow. Please take a moment now to acquaint yourself with these instructions and the many features of your Hampton® Stove.



WARNING!

HOT GLASS WILL CAUSE BURNS

DO NOT TOUCH GLASS UNTIL COOLED

NEVER ALLOW CHILDREN TO TOUCH GLASS



NATIONAL FIREPLACE INSTITUTE
NFI
CERTIFIED
www.nficertified.org

We recommend that our products be installed and serviced by professionals who are certified in the U.S. by the National Fireplace Institute® (NFI) or in Canada by Wood Energy Technical Training (WETT).



Wood Energy Technical Training
www.wettinc.ca



H15 Product Video



UNIT DIMENSIONS

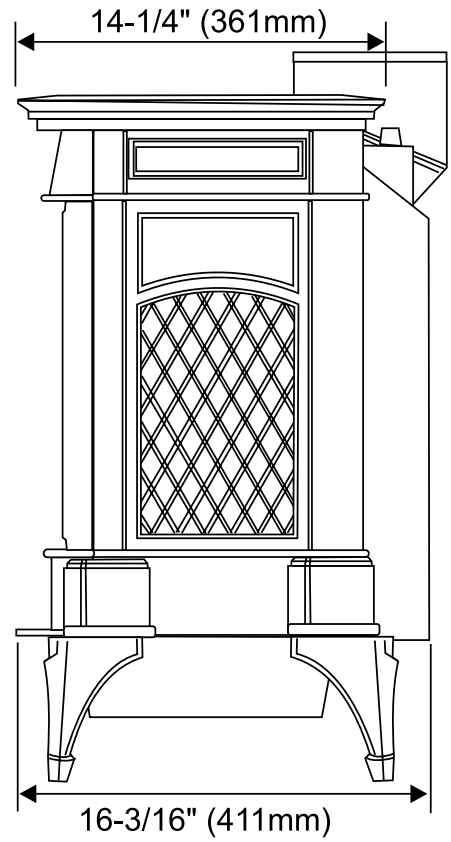
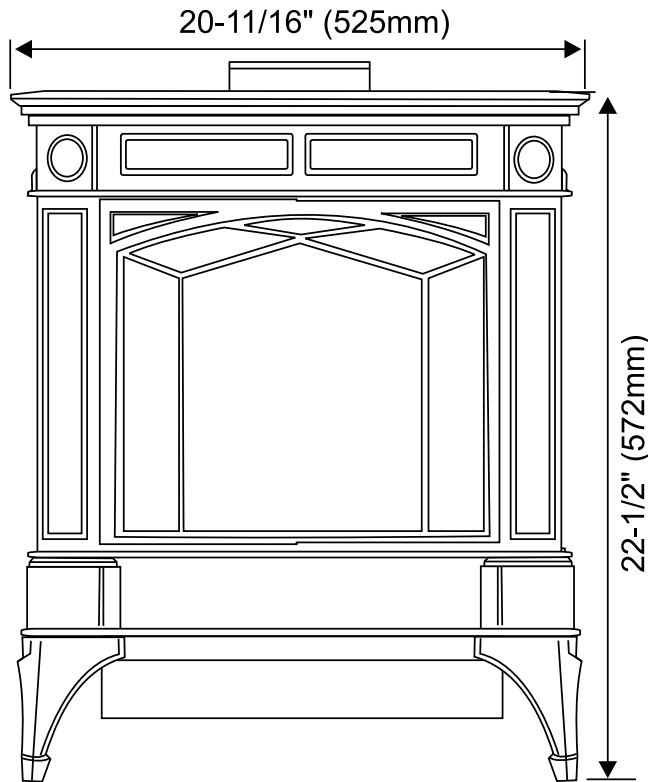

DIMENSIONS

Unit Dimensions	3
-----------------------	---

SAFETY LABEL

Copy of Safety Decal.....	5
---------------------------	---

REQUIREMENTS

MA Code - CO Detector.....	5
----------------------------	---

INSTALLATION

Important Message	7
Specifications	7
Manufactured Homes After First Sale.....	7
Before You Start	7
General Safety Information.....	8
Installation Checklist.....	8
Clearances to Combustibles.....	9
Locating Your Gas Stove.....	9
Manufactured Mobile Home Additional Requirements ..	9
Combustion and Ventilation Air.....	9
Optional Fan Installation.....	10
Venting Introduction.....	12
Installation Precautions	12
Safety Precautions for the Installer.....	12
Vent Restrictor Position	12
Rotating Elbow	12
Exterior Vent Terminal Locations	13
4" x 6-5/8" Rigid Pipe	14
Cross Reference Chart.....	14
Rigid Pipe Venting Systems	16
Venting Arrangements	19
Vertical Termination with Co-linear Flex System	20
DV Stove Horizontal Vent Kit.....	21
Residential and Manufactured Homes	23
Minimum Horizontal Termination Installations	23
Dura-Vent Termination Kit.....	24
Horizontal terminations.....	25
Vertical Terminations	26
Converting Class-A Metal Chimney or Masonry Chimney to Direct Vent System.....	28
Cathedral Ceilings	29
High Elevation	29
Gas Connection.....	29
Aeration Adjustment	30
Gas Pipe Pressure Testing	30

Conversion from NG to LP	31
Log Set Installation	34
Optional Wall Thermostat	36
Optional Remote Control	36
Final Check.....	36
Wiring Diagrams.....	37

OPERATING INSTRUCTIONS

Operating Instructions	39
Lighting Procedure	39
Shutdown Procedure	39
First Fire	39
Adjusting Flame Height	39
Automatic Convection Fan Operation.....	39
Copy of the Lighting Plate Instructions	40
Normal Operating Sounds of Gas Appliances	41

MAINTENANCE

Maintenance Instructions.....	41
Pilot Adjustment.....	41
Fan Maintenance.....	42
General Vent Maintenance	42
Log Replacement	42
Glass Replacement	42
Removing Valve.....	43
Installing Valve Assembly	43

PARTS LIST

Main Assembly	44
Burner & Log Assembly	45

WARRANTY

Warranty	47
----------------	----

This is a copy of the label that accompanies each Direct Vent Freestanding Gas Stove. We have printed a copy of the contents here for your review.

NOTE: Hampton® units are constantly being improved. Check the label on the unit and if there is a difference, the label on the unit is the correct one.

DUPLICATE SERIAL NO.		301																																						
<p>Listed: VENTED GAS FIREPLACE HEATER / FOYER AU GAZ À ÉVACUATION Certified for/Certifiée pour: CANADA and U.S.A. Tested to: CGA-2-17-M91, ANSI Z21.88a-2007 / CSA 2.33a-2007 WN# 16443 MAY BE INSTALLED IN MANUFACTURED (MOBILE) HOMES AFTER FIRST SALE</p>		<p>DO NOT REMOVE THIS LABEL / NE PAS ENLEVER CETTE ÉTIQUETTE Serial No./ No de serie 301</p>																																						
	<p>NATURAL GAS STOVE: Model H15-NG1</p> <table border="0"> <tr><td>Minimum supply pressure</td><td>5" WC/C.E. (1.25 kPa)</td><td>APPAREIL FONCTIONNANT AU NATURAL GAS</td></tr> <tr><td>Manifold pressure High</td><td>3.8" WC/C.E. (0.94 kPa)</td><td>CONCU POUR ETRE POELE: Modéle H15-NG1</td></tr> <tr><td>Manifold pressure Low</td><td>1.1" WC/C.E. (0.27 kPa)</td><td>Pression d'alimentation minimum</td></tr> <tr><td>Maximum Input</td><td>18,000 Btu/h (5.28 Kw/h)</td><td>Pression à la tubulure d'échappement élevée</td></tr> <tr><td>Minimum Input</td><td>10,500 Btu/h (3.08 Kw/h)</td><td>Pression à la tubulure d'échappement basse</td></tr> <tr><td>Orifice size</td><td>#47 DMS</td><td>Débit Calorifique maximum</td></tr> <tr><td>Altitude</td><td>0-4500 ft/pi (0-1372m)</td><td>Débit Calorifique minimum</td></tr> <tr><td></td><td></td><td>Dimensions de l'orifice</td></tr> <tr><td></td><td></td><td>L'altitude</td></tr> </table>	Minimum supply pressure	5" WC/C.E. (1.25 kPa)	APPAREIL FONCTIONNANT AU NATURAL GAS	Manifold pressure High	3.8" WC/C.E. (0.94 kPa)	CONCU POUR ETRE POELE: Modéle H15-NG1	Manifold pressure Low	1.1" WC/C.E. (0.27 kPa)	Pression d'alimentation minimum	Maximum Input	18,000 Btu/h (5.28 Kw/h)	Pression à la tubulure d'échappement élevée	Minimum Input	10,500 Btu/h (3.08 Kw/h)	Pression à la tubulure d'échappement basse	Orifice size	#47 DMS	Débit Calorifique maximum	Altitude	0-4500 ft/pi (0-1372m)	Débit Calorifique minimum			Dimensions de l'orifice			L'altitude	<p>Minimum Clearances to Combustibles / Degagement Minimum De Materiaux Combustibles</p> <p>Minimum ceiling height from top of unit: 24"/610mm Minimum plafond hauteur en haut de l'appareil: 24"/610mm</p> <p>A 6" / 150mm C 2" / 50mm B 0" / 0mm E 2" / 50mm See Manual for details</p> <p>Minimum clearance of Vent Terminal to Outside Corner & Inside Corner: with AstroCap 6"/150mm with Dura-Vent Cap 12"/300mm Electrical supply / Électrique 115VAC, 1.13A, 60Hz.</p> <p>FPI Fireplace Products International Ltd. Delta, BC, Canada</p> <p>Made in Canada/ Fabrique au Canada 918-494b</p>											
Minimum supply pressure	5" WC/C.E. (1.25 kPa)	APPAREIL FONCTIONNANT AU NATURAL GAS																																						
Manifold pressure High	3.8" WC/C.E. (0.94 kPa)	CONCU POUR ETRE POELE: Modéle H15-NG1																																						
Manifold pressure Low	1.1" WC/C.E. (0.27 kPa)	Pression d'alimentation minimum																																						
Maximum Input	18,000 Btu/h (5.28 Kw/h)	Pression à la tubulure d'échappement élevée																																						
Minimum Input	10,500 Btu/h (3.08 Kw/h)	Pression à la tubulure d'échappement basse																																						
Orifice size	#47 DMS	Débit Calorifique maximum																																						
Altitude	0-4500 ft/pi (0-1372m)	Débit Calorifique minimum																																						
		Dimensions de l'orifice																																						
		L'altitude																																						
	<p>PROPANE GAS STOVE: Model H15-LP1</p> <table border="0"> <tr><td>Minimum supply pressure</td><td>12" WC/C.E. (3.00 kPa)</td><td>APPAREIL FONCTIONNANT AU PROPANE</td></tr> <tr><td>Manifold pressure High</td><td>11" WC/C.E. (2.74 kPa)</td><td>CONCU POUR ETRE POELE: Modéle H15-LP1</td></tr> <tr><td>Manifold pressure Low</td><td>2.9" WC/C.E. (0.72 kPa)</td><td>Pression d'alimentation minimum</td></tr> <tr><td>Maximum Input</td><td>18,000 Btu/h (5.28 Kw/h)</td><td>Pression à la tubulure d'échappement élevée</td></tr> <tr><td>Minimum Input</td><td>10,600 Btu/h (3.10 Kw/h)</td><td>Pression à la tubulure d'échappement basse</td></tr> <tr><td>Orifice size</td><td>#55 DMS</td><td>Débit Calorifique maximum</td></tr> <tr><td>Altitude</td><td>0-2000 ft/pi (0-610m)</td><td>Débit Calorifique minimum</td></tr> <tr><td>Maximum Input</td><td>15,500 Btu/h (4.54 Kw/h)</td><td>Dimensions de l'orifice</td></tr> <tr><td>Minimum Input</td><td>8,200 Btu/h (2.40 Kw/h)</td><td>L'altitude</td></tr> <tr><td>Orifice size</td><td>#56 DMS</td><td>Débit Calorifique maximum</td></tr> <tr><td>Altitude</td><td>2000-4500 ft/pi (610-1372m)</td><td>Débit Calorifique minimum</td></tr> <tr><td></td><td></td><td>Dimensions de l'orifice</td></tr> <tr><td></td><td></td><td>L'altitude</td></tr> </table>	Minimum supply pressure	12" WC/C.E. (3.00 kPa)	APPAREIL FONCTIONNANT AU PROPANE	Manifold pressure High	11" WC/C.E. (2.74 kPa)	CONCU POUR ETRE POELE: Modéle H15-LP1	Manifold pressure Low	2.9" WC/C.E. (0.72 kPa)	Pression d'alimentation minimum	Maximum Input	18,000 Btu/h (5.28 Kw/h)	Pression à la tubulure d'échappement élevée	Minimum Input	10,600 Btu/h (3.10 Kw/h)	Pression à la tubulure d'échappement basse	Orifice size	#55 DMS	Débit Calorifique maximum	Altitude	0-2000 ft/pi (0-610m)	Débit Calorifique minimum	Maximum Input	15,500 Btu/h (4.54 Kw/h)	Dimensions de l'orifice	Minimum Input	8,200 Btu/h (2.40 Kw/h)	L'altitude	Orifice size	#56 DMS	Débit Calorifique maximum	Altitude	2000-4500 ft/pi (610-1372m)	Débit Calorifique minimum			Dimensions de l'orifice			L'altitude
Minimum supply pressure	12" WC/C.E. (3.00 kPa)	APPAREIL FONCTIONNANT AU PROPANE																																						
Manifold pressure High	11" WC/C.E. (2.74 kPa)	CONCU POUR ETRE POELE: Modéle H15-LP1																																						
Manifold pressure Low	2.9" WC/C.E. (0.72 kPa)	Pression d'alimentation minimum																																						
Maximum Input	18,000 Btu/h (5.28 Kw/h)	Pression à la tubulure d'échappement élevée																																						
Minimum Input	10,600 Btu/h (3.10 Kw/h)	Pression à la tubulure d'échappement basse																																						
Orifice size	#55 DMS	Débit Calorifique maximum																																						
Altitude	0-2000 ft/pi (0-610m)	Débit Calorifique minimum																																						
Maximum Input	15,500 Btu/h (4.54 Kw/h)	Dimensions de l'orifice																																						
Minimum Input	8,200 Btu/h (2.40 Kw/h)	L'altitude																																						
Orifice size	#56 DMS	Débit Calorifique maximum																																						
Altitude	2000-4500 ft/pi (610-1372m)	Débit Calorifique minimum																																						
		Dimensions de l'orifice																																						
		L'altitude																																						
<p>This appliance must be installed in accordance with local codes, if any; if none, follow the National Fuel Gas Code, ANSI Z223.1, or Natural Gas and Propane Installation Code, CSA B149.1.</p> <p>This appliance must be installed in accordance with the Standard CAN/CSA Z240 MH, Mobile Housing, in Canada, or with the Manufactured Home Construction and Safety Standard, Title 24 CFR, Part 3280, in the United States, or when such a standard is not applicable, ANSI/NCSCBS A225.1/NFPA 501A, Manufactured Home Installations Standard or ANSI A119.2 ou NFPA 501C Standard for Recreational Vehicles</p> <p>This appliance is only for use with the type of gas indicated on the rating plate and may be installed in an aftermarket, permanently located, manufactured (mobile) home where not prohibited by local codes. See owner's manual for details.</p> <p>Installer l'appareil selon les codes ou règlements locaux, ou, en l'absence de tels règlements, selon les codes d'installation ANSI Z223.1, National Fuel Gas Code ou CSA-B149.1 en vigueur.</p> <p>Installer l'appareil selon la norme CAN/CSA-Z240, Série MM, Maison mobiles ou CAN/CSA-Z240 VC, Véhicules de camping, ou la norme 24 CFR Part 3280, Manufactured Home Construction and Safety Standard. Si ces normes ne sont pas pertinentes, utilisez la norme ANSI/NCSCBS A225.1/NFPA 501A, Manufactured Home Installations Standard, ou ANSI A119.2 ou NFPA 501C Standard for Recreational Vehicles.</p> <p>Cet appareil doit être utilisé uniquement avec le type de gaz indiqué sur la plaque signalétique. Cet appareil peut être installé dans une maison préfabriquée ou mobile (É.-U. seulement) installée à demeure si les règlements locaux le permettent. Voir la notice de l'utilisateur pour plus de renseignements. Cet appareil ne peut pas être utilisé avec d'autres gaz sauf si une trousse de conversion certifiée est fournie.</p> <p>This vented gas fireplace heater is not for use with air filters. Ne pas utiliser de filtre à air avec ce foyer au gaz à évacuation. For use with glass doors certified with the appliance only. Pour utilisation uniquement avec les portes en verre certifiées avec l'appareil.</p> <p>VENTED GAS FIREPLACE HEATER - NOT FOR USE WITH SOLID FUELS. FOYER AU GAZ À ÉVACUATION - NE PAS UTILISER AVEC DUCOMBUSTIBLE SOLIDE.</p>																																								

For the State of Massachusetts, installation and repair must be done by a plumber or gasfitter licensed in the Commonwealth of Massachusetts.

For the State of Massachusetts, flexible connectors shall not exceed 36 inches in length.

For the State of Massachusetts, the appliances individual manual shut-off must be a t-handle type valve.

The State of Massachusetts requires the installation of a carbon monoxide alarm in accordance with NFPA 720 and a CO alarm with battery back up in the same room where the gas appliance is installed.

MA Code - CO Detector (for the State of Massachusetts only)

5.08: Modifications to NFPA-54, Chapter 10

(2) Revise 10.8.3 by adding the following additional requirements:

(a) For all side wall horizontally vented gas fueled equipment installed in every dwelling, building or structure used in whole or in part for residential purposes, including those owned or operated by the Commonwealth and where the side wall exhaust vent termination is less than seven (7) feet above finished grade in the area of the venting, including but not limited to decks and porches, the following requirements shall be satisfied:

1. **INSTALLATION OF CARBON MONOXIDE DETECTORS.** At the time of installation of the side wall horizontal vented gas fueled equipment, the installing plumber or gasfitter shall observe that a hard wired carbon monoxide detector with an alarm and battery back-up is installed on the floor level where the gas equipment is to be installed. In addition, the installing plumber or gasfitter shall observe that a battery operated or hard wired carbon monoxide detector with an alarm is installed on each additional level of the dwelling, building or structure served by the side wall horizontal vented gas fueled equipment. It shall be the responsibility of the property owner to secure the services of qualified licensed professionals for the installation of hard wired carbon monoxide detectors

a. In the event that the side wall horizontally vented gas fueled equipment is installed in a crawl space or an attic, the hard wired carbon monoxide detector with alarm and battery back-up may be installed on the next adjacent floor level.

b. In the event that the requirements of this subdivision can not be met at the time of completion of installation, the owner shall have a period of thirty (30) days to comply with the above requirements; provided, however, that during said thirty (30) day period, a battery operated carbon monoxide detector with an alarm shall be installed.

2. **APPROVED CARBON MONOXIDE DETECTORS.** Each carbon monoxide detector as required in accordance with the above provisions shall comply with NFPA 720 and be ANSI/UL 2034 listed and IAS certified.

3. **SIGNAGE.** A metal or plastic identification plate shall be permanently mounted to the exterior of the building at a minimum height of eight (8) feet above grade directly in line with the exhaust vent terminal for the horizontally vented gas fueled heating appliance or equipment. The sign shall read, in print size no less than one-half (1/2) inch in size, "**GAS VENT DIRECTLY BELOW. KEEP CLEAR OF ALL OBSTRUCTIONS**".

4. **INSPECTION.** The state or local gas inspector of the side wall horizontally vented gas fueled equipment shall not approve the installation unless, upon inspection, the inspector observes carbon monoxide detectors and signage installed in accordance with the provisions of 248 CMR 5.08(2)(a)1 through 4.

(b) **EXEMPTIONS:** The following equipment is exempt from 248 CMR 5.08(2)(a)1 through 4:

1. The equipment listed in Chapter 10 entitled "Equipment Not Required To Be Vented" in the most current edition of NFPA 54 as adopted by the Board; and

2. Product Approved side wall horizontally vented gas fueled equipment installed in a room or structure separate from the dwelling, building or structure used in whole or in part for residential purposes.

(c) **MANUFACTURER REQUIREMENTS - GAS EQUIPMENT VENTING SYSTEM PROVIDED.** When the manufacturer of Product Approved side wall horizontally vented gas equipment provides a venting system design or venting system components with the equipment, the instructions provided by the manufacturer for installation of the equipment and the venting system shall include:

1. Detailed instructions for the installation of the venting system design or the venting system components; and

2. A complete parts list for the venting system design or venting system.

(d) **MANUFACTURER REQUIREMENTS - GAS EQUIPMENT VENTING SYSTEM NOT PROVIDED.** When the manufacturer of a Product Approved side wall horizontally vented gas fueled equipment does not provide the parts for venting the flue gases, but identifies "special venting systems", the following requirements shall be satisfied by the manufacturer:

1. The referenced "special venting system" instructions shall be included with the appliance or equipment installation instructions; and

2. The "special venting systems" shall be Product Approved by the Board, and the instructions for that system shall include a parts list and detailed installation instructions.

(e) A copy of all installation instructions for all Product Approved side wall horizontally vented gas fueled equipment, all venting instructions, all parts lists for venting instructions, and/or all venting design instructions shall remain with the appliance or equipment at the completion of the installation.

IMPORTANT MESSAGE SAVE THESE INSTRUCTIONS

The Direct Vent Freestanding Gas Stove must be installed in accordance with these instructions. Carefully read all the instructions in this manual first. Consult the building authority having jurisdiction to determine the need for a permit prior to starting the installation.

Note: Failure to follow the instructions could cause a malfunction of the heater which could result in death, serious bodily injury, and/or property damage. Failure to follow these instructions may also void your fire insurance and/or warranty.

Note: These instructions take precedence over Simpson Dura-Vent instructions.

SPECIFICATIONS

Fuels: H15-NG1 is approved for use with natural gas.

H15-LP1 is approved for use with liquefied petroleum gases (propane).

Electrical: 120V A.C. system.

Optional Circulation Fan:
Variable speed, 125/75.

Log Sets: Ceramic fibre, 4 per set.

Vent System: Coaxial (6-5/8" outer / 4" inner liner) rigid flue and termination cap.

MOBILE / MANUFACTURED HOMES AFTER FIRST SALE

This Hampton® product has been tested and listed by ITS Testing Services as a Direct Vent Room Heater to the following standards: CGA-2.17-M91, and ANSI Z21.88a-2007/CSA 2.33a-2007.

This Direct Vent System Appliance must be installed in accordance with the manufacturer's installation instructions and the Manufactured Home Construction and Safety Standard, Title 24 CFR, Part 3280, or the current Standard of Fire Safety Criteria for Manufactured Home Installations, Sites, and Communities ANSI/NFPA 501A, and with CAN/CSAZ240-MH Mobile Home Standard in Canada.

This appliance installation must comply with the manufacturer's installation instructions and local codes, if any. In the absence of local codes follow the current National Fuel Gas Code, ANSI Z223.1 and the current National Electrical Code ANSI/NFPA 70 in the U.S.A., and the current CAN/CGA B149 Gas Installation Code and the current Canadian Electrical Code CSA C22.1 in Canada.

This Hampton® Mobile/Manufactured Home Listed appliance comes factory equipped with a means to secure the unit.

This Hampton® Mobile/Manufactured Home listed appliance comes equipped with a dedicated #8 ground lug to which an 18 gauge copper wire from the steel chassis ground must be attached.

This appliance may only be installed in an aftermarket permanently located, manufactured (USA only) or mobile home, where not prohibited by local codes.

This appliance is only for use with the type of gas indicated on the rating plate. This appliance is not convertible for use with other gases, unless a certified kit is used.

BEFORE YOU START

Safe installation and operation of this appliance requires common sense, however, we are required by the Canadian Safety Standards and ANSI Standards to make you aware of the following:

INSTALLATION AND REPAIR SHOULD BE DONE BY AN AUTHORIZED SERVICE PERSON. THE APPLIANCE SHOULD BE INSPECTED BEFORE USE AND AT LEAST ANNUALLY BY A PROFESSIONAL SERVICE PERSON. MORE FREQUENT CLEANING MAY BE REQUIRED DUE TO EXCESSIVE LINT FROM CARPETING, BEDDING MATERIAL, ETC. IT IS IMPERATIVE THAT CONTROL COMPARTMENTS, BURNERS AND CIRCULATING AIR PASSAGEWAYS OF THE APPLIANCE BE KEPT CLEAN.

DUE TO HIGH TEMPERATURES, THE APPLIANCE SHOULD BE LOCATED OUT OF TRAFFIC AND AWAY FROM FURNITURE AND DRAPERIES.

WARNING: FAILURE TO INSTALL THIS APPLIANCE CORRECTLY WILL VOID YOUR WARRANTY AND MAY CAUSE A SERIOUS HOUSE FIRE.

CHILDREN AND ADULTS SHOULD BE ALERTED TO THE HAZARDS OF HIGH SURFACE TEMPERATURES, ESPECIALLY THE FIREPLACE GLASS, AND SHOULD STAY AWAY TO AVOID BURNS OR CLOTHING IGNITION.



YOUNG CHILDREN SHOULD BE CAREFULLY SUPERVISED WHEN THEY ARE IN THE SAME AREA AS THE APPLIANCE. TODDLERS, YOUNG CHILDREN AND OTHERS MAY BE SUSCEPTIBLE TO ACCIDENTAL CONTACT BURNS. A PHYSICAL BARRIER IS RECOMMENDED IF THERE ARE AT RISK INDIVIDUALS IN THE HOUSE. TO RESTRICT ACCESS TO A FIREPLACE OR STOVE, INSTALL AN ADJUSTABLE SAFETY GATE TO KEEP TODDLERS, YOUNG CHILDREN AND OTHER AT RISK INDIVIDUALS OUT OF THE ROOM AND AWAY FROM HOT SURFACES.

CLOTHING OR OTHER FLAMMABLE MATERIAL SHOULD NOT BE PLACED ON OR NEAR THE APPLIANCE.

INSTALLATION

- 1) Provide adequate clearances for servicing, proper operation and around the air openings into the combustion chamber.
 - 2) The appliance must be installed on a flat, solid, continuous surface (e.g. wood, metal, concrete). This may be the floor, or it can be raised up on a platform to enhance its visual impact. The appliance may be installed on carpeting, tile, wood flooring or other combustible material, because the appliance's base extends the full width and depth of the appliance. The Direct Vent Freestanding Gas Stove can be installed in a wide variety of ways and will fit nearly any room layout. It may be installed in a recessed position, framed out into the room, or across a corner.
 - 3) The Direct Vent Freestanding Gas Stove is approved for alcove installations, which meet the clearances listed in the "Clearance to Combustibles" section. This unit is approved for manufactured home installations, see the "Manufactured Mobile Home Additional Requirements" and "Rigid Pipe Venting Systems" sections for the required vent arrangements. If installed into a manufactured home the unit must be bolted down to the floor.
 - 4) This appliance is Listed for bedroom installations when used with a Listed Millivolt Thermostat. Some areas may have further requirements, check local codes before installation.
 - 5) This appliance is Listed for Alcove installations, maintain minimum Alcove clearances as follows, minimum width of 32-1/2" (825mm), a maximum depth of 36" (914mm), and minimum height of 24" (610mm) from top of unit to ceiling.
 - 6) We recommend that you plan your installation on paper using exact measurements for clearances and floor protection before actually installing this appliance. Have a qualified building inspector review your plans before installation.
 - 3) The appliance should be inspected for shipping damage before use and **serviced annually by a professional service person**. More frequent cleaning may be required due to excessive lint from carpeting, bedding material, etc. It is imperative that control compartments, and circulating air passageways of the appliance be kept clean and free from excessive lint from carpeting.
 - 4) See general construction and assembly instructions. The appliance and vent should be enclosed when installed in or passing through a living area, where children may come in contact with it.
 - 5) This appliance must be connected to the specified vent and termination cap to the outside of the building envelope. Never vent to another room or inside a building. Make sure that the vent is fitted as per the instructions starting in the "Exterior Vent Terminal Locations" section.
 - 6) Inspect the venting system annually for blockage and any signs of deterioration.
 - 7) Venting terminals shall not be recessed into a wall or siding.
 - 8) Any safety glass removed for servicing must be replaced prior to operating the appliance.
 - 9) To prevent injury, do not allow anyone who is unfamiliar with the operation to use the fireplace.
 - 7) Install standard and optional features. Refer to the following sections where applicable:
 - a. Log Set Installation
 - b. Wall Thermostat
 - c. Remote Control
 - 8) Final check. Refer to the "Final Check" section.
- Before leaving this unit with the customer, the installer must ensure that the appliance is firing correctly and **operation fully explained to customer**.
- This includes:**
- 1) Clocking the appliance to ensure the correct firing rate (rate noted on label) after burning appliance for 15 minutes.
 - 2) If required, adjusting the primary air to ensure that the flame does not carbon. First allow the unit to burn for 15-20 min. to stabilize.

CAUTION: Any alteration to the product that causes sooting or carboning that results in damage is not the responsibility of the manufacturer.

INSTALLATION CHECKLIST

- 1) Locate your gas appliance. Refer to the following sections:
 - a. Locating Your Gas Stove
 - b. Clearances to Combustibles
 - c. "Venting Introduction" to "Exterior Vent Terminal Locations" sections.
- 2) Install Optional Fan. Refer to the "Optional Fan Installation" section.
- 3) Set vent restrictor. Refer to the "Vent Restrictor Position" section.
- 4) Install venting: Check all venting requirements. See "Venting Introduction" to "Dura-Vent Vertical Termination" sections.
- 5) Make gas connections. Refer to the "Gas Connection" section.

Test the pilot. Must be as per diagram in the "Pilot Adjustment" section.

If converting to Propane, make changes prior as instructed in the "Conversion from Natural Gas to Propane" section.

- 6) Test Gas Pressure. Refer to the "Gas Pipe Pressure Testing" section.

GENERAL SAFETY INFORMATION

- 1) The appliance installation must conform with local Canadian Electrical Code.
- 2) The appliance when installed, must be electrically grounded in accordance with local codes, or in the absence of local codes with the current National Electrical Code, ANSI/NFPA 70 or CSA C22.1 Canadian Electrical Code.

Emissions from burning wood or gas could contain chemicals known to the State of California to cause cancer, birth defects or other reproductive harm.

CLEARANCES TO COMBUSTIBLES

The clearances listed are MINIMUM distances. Measure the clearance to both the appliance and the chimney connector. **The farthest distance is correct if the two clearances do not coincide.**

For example, if the appliance is set as indicated in one of the figures but the connector is too close, move the stove until the correct clearance to the connector is obtained.

This appliance may be installed only with the clearances as shown in the situations pictured. **Do not combine clearances from one type of installation with another in order to achieve closer clearances.**

This unit can be installed on a solid combustible surface like a wood floor. This unit can also be installed directly on carpeting or vinyl.

Use the minimum clearances shown in the diagrams below:

H15-NG1 & H15-LP1 Clearances

- A Left Side Wall to Unit* 6" / 150 mm
- *B Back Wall to Unit 0" / 0 mm
- C Vertical Vent Pipe to Back Wall 2" / 50 mm
- E Unit Corner to Wall 2" / 50 mm
- Unit Top to Alcove Ceiling 24" / 610 mm

Minimum ceiling height is 24" / 610 mm from top of unit.

*IMPORTANT

It is recommended that unit is moved away from the wall, if installing the blower option, so the fan can be easily installed and/or serviced.

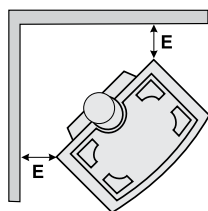
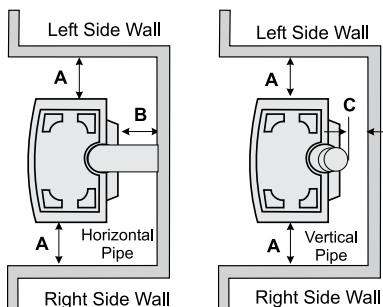

LOCATING YOUR GAS STOVE

When selecting a location for your stove, ensure that the clearances listed above are met as well as ensuring that there is adequate accessibility for servicing and proper operation.

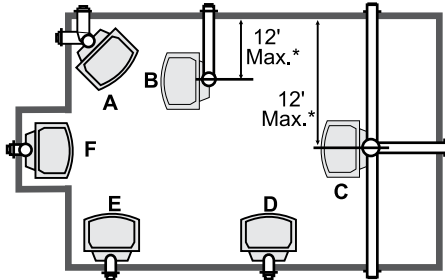

* 12' max. only if vertical height is achieved.

- A) Cross Corner
- B) Room Divider
- C) Island
- D) Flat on Wall
- E) Flat on Wall Corner
- F) Flush with Wall/Alcove

For Vent Termination requirements, see the "Exterior Vent Terminal Locations" section.

MANUFACTURED MOBILE HOME ADDITIONAL REQUIREMENTS

- 1) Ensure that structural members are not cut or weakened during installation.
- 2) Ensure proper grounding using the #8 ground lug provided.
- 3) Appliance must be anchored to the floor with the supplied anchoring methods.

COMBUSTION AND VENTILATION AIR

The combustion air from this appliance is drawn from outside the building through the outer flue. **Extra provision for combustion air inside the room is not required.**

INSTALLATION

OPTIONAL FAN INSTALLATION

Fan Kit Contains:

- Qty. Description
- 1 Fan Assembly c/w green wire attached
- 1 Thermodisc
- 1 Fan Speed Control
- 1 Grommet

1) Remove the rear access panel on the back of the stove by removing the 2 screws under the rear panel, then lift rear panel off of 2 bolts at the top. Take care not to cut wires when lowering the panel.



screw screw



bolt

Lift Rear Panel off of the 2 top bolts.

2) Disconnect the red and grey wires.

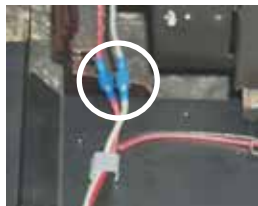

3) Remove the Top Control Panel Assembly by removing the three screws.



Top Control Panel Assembly

4) Remove the nylon hole plug from the control panel.

5) Install the fan speed controller onto the control panel and secure with nut and washer. Connect the red and black wires from the wire harness to speed controller. **NOTE: Speed control wires must be in the down position when control panel is in place.**

6) Push black knob onto speed control.

7) Re-attach control panel with 3 screws, reversing step 3.

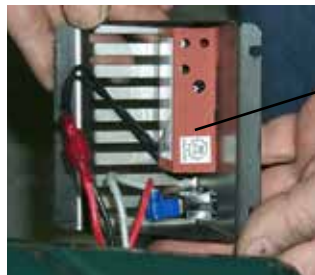

Fan Speed Controller



8) Slide Thermodisc into the bracket on the left side of the rear firebox.



Thermodisc Bracket

Thermodisc

9) Remove 2 screws from unit.



10) Place grommet in rear plate through the bottom of the opening as shown below.



Rear Plate

Grommet

11) Place the blower close to the base of the unit and feed the wires through the grommet in the rear plate.

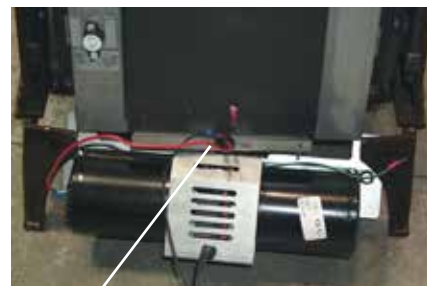

Wires

- 12) Slide fan into place and secure with the two screws removed in step 9.



- 13) Connect long black & red wires to thermodisc and secure wires.

- 14) Connect fan ground wire to lug nut at base of unit.

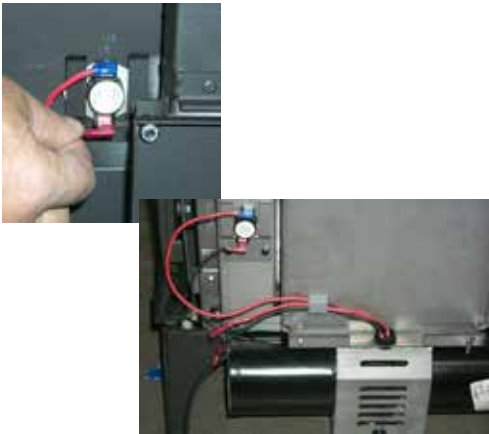

- 15) Before re-attaching the rear access panel, the valve wires and the fan wires need to be connected.



Re-connect the red and grey valve wires removed in step 2.

Connect the black and white fan wires as per the wiring diagram below.



- 16) Slide the Rear Access Panel back into position and secure with 2 screws.

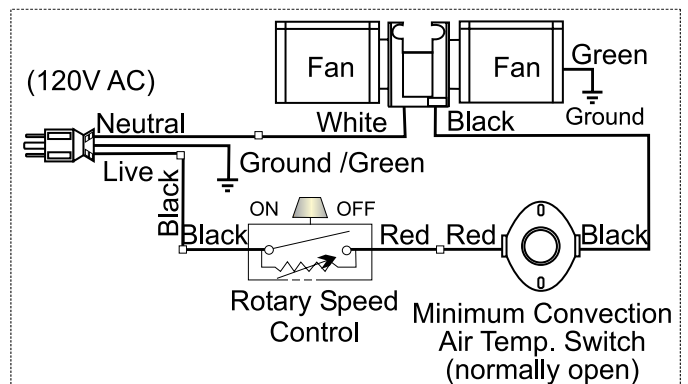
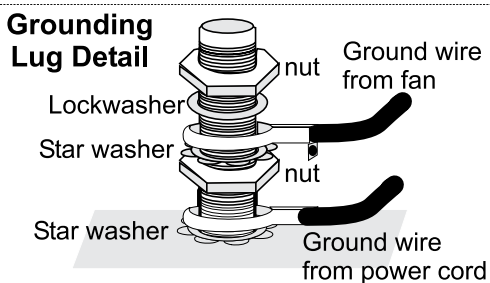

WARNING: Electrical Grounding Instructions
 This appliance is equipped with a three pronged (grounding) plug for your protection against shock hazard and should be plugged directly into a properly grounded three-prong receptacle. Do not cut or remove the grounding prong from this plug.

INSTALLATION

VENTING INTRODUCTION

The Horizontal Termination Kit and the Simpson Dura-Vent Direct Vent venting systems, in combination with the Direct Vent Freestanding Gas Stoves, H15-NG1, and H15-LP1, have been tested and listed as direct vent heater systems by Warnock Hersey.

These units use the "balanced flue" technology Co-Axial system. The inner liner vents products of combustion to the outside while the outer pipe draws outside combustion air into the combustion chamber thereby eliminating the need to use heated room air for combustion and losing warm room air up the chimney.

Note: These flue pipes must not be connected to any other appliance.

The gas appliance and vent system must be vented directly to the outside of the building, and never be attached to a chimney serving a separate solid fuel or gas burning appliance. Each direct vent gas appliance must use its own separate vent system. Common vent systems are prohibited.

IMPORTANT

Read all instructions carefully before starting the installation. Failure to follow these instructions may create a fire or other safety hazard, and will void the warranty. Be sure to check the venting and clearance to combustible requirements. Consult your local building codes before beginning installation.

The location of the termination cap must conform to the requirements in the "Exterior Vent Terminal Locations" section.

INSTALLATION PRECAUTIONS

These venting systems are engineered products that have been designed and tested for use with the H15-NG1, and H15-LP1. The warranty will be voided and serious fire, health or other safety hazards may result from any of the following actions:

- 1) Installation of any damaged Rigid Pipe component.
- 2) Unauthorized modification of any Rigid Pipe System.
- 3) Installation other than as instructed by Simpson Dura-Vent and FPI Fireplace Products International Ltd.

Warning: Always maintain required clearances (air spaces) to nearby combustibles to prevent a fire hazard. Do not fill air spaces with insulation.

Be sure to check the vent termination clearance requirements from decks, windows, soffits, gas regulators, air supply inlets and public walkways as specified in the "Exterior Vent Terminal Locations" section and in your local building codes.

The gas appliance and vent system must be vented directly to the outside of the building, and never be attached to a chimney serving a separate solid fuel or gas-burning appliance. Each direct vent gas appliance must use its own separate vent system. Common vent systems are prohibited.

SAFETY PRECAUTIONS FOR THE INSTALLER

- 1) Wear gloves and safety glasses for protection.
- 2) Exercise extreme caution when using ladders or on roof tops.
- 3) Be aware of electrical wiring locations in walls and ceilings.

VENT RESTRICTOR POSITION

To set the Vent restriction as indicated in the Venting Arrangement diagrams in the "Rigid Pipe Venting System" section, simply loosen the screws and push the vent restrictor plate to the correct position. Tighten the screws. This will be located inside the firebox.

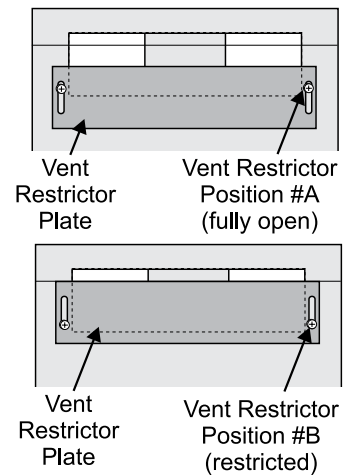

ROTATING ELBOW

- 1) Remove top casting.

- 2) Remove all 4 screws that secure the elbow to the unit using a 1/4" magnetic nut driver.

Remove all 4 screws and washers



- 3) Rotate the elbow 180°

- 4) Secure the elbow by securing it with the 4 screws.



EXTERIOR VENT TERMINAL LOCATIONS

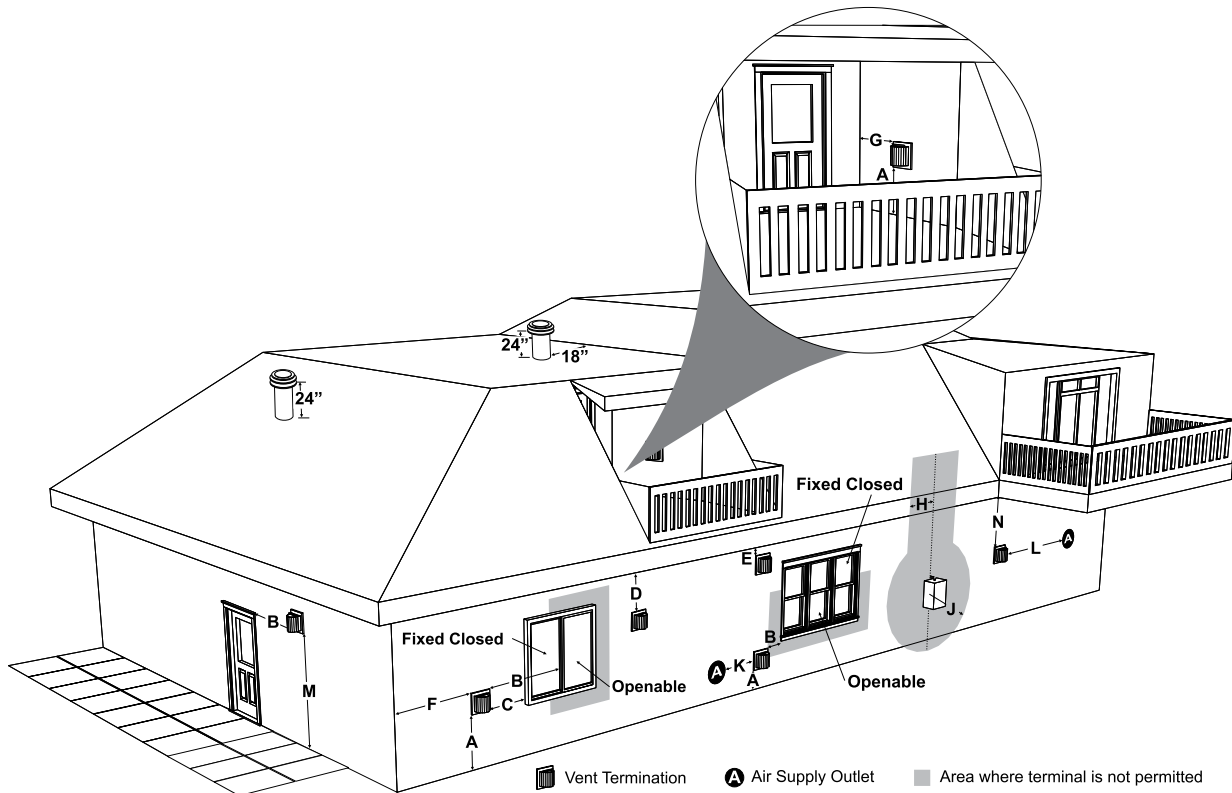

	Minimum Clearance Requirements	Canada ¹	USA ²
A	Clearance above grade, veranda, porch, deck, or balcony	12"(30cm)	12"(30cm)
B	Clearance to window or door that may be opened	12"(30cm)	9" (23cm)
C	Clearance to permanently closed window	*	*
D	Vertical clearance to ventilated soffit located above the terminal within a horizontal distance of 2 feet (61cm) from the center line of the terminal (check with the local code)	22"(56cm)	22"(56cm)
E	Clearance to unventilated soffit	12"(30cm)	12"(30cm)
F	Clearance to outside corner: with AstroCap and Vent Riser Termination Cap	6"(15cm)	6"(15cm)
	Clearance to outside corner: with all other approved Termination Caps.	12"(30cm)	12"(30cm)
G	Clearance to inside corner: with AstroCap and Vent Riser Termination Cap	6"(15cm)	6"(15cm)
	Clearance to inside corner: with all other approved Termination Caps	12"(30cm)	12"(30cm)
H	Clearance to each side of center line extended above meter/regulator assembly	36"(90cm) ^a	*
J	Clearance to service regulator vent outlet	36"(90cm)	*
K	Clearance to non-mechanical air supply inlet to building or the combustion air inlet to any other appliance	12"(30cm)	9" (23cm)
L	Clearance to a mechanical air supply inlet #3' (91cm) above if within 10' (3m) horizontally.	72"(1.8m)	36"(90cm) ^b
M	Clearance above paved sidewalk or a paved driveway located on public property	84"(2.1m) [†]	*
N	Clearance under veranda, porch, deck, or balcony	12"(30cm) [‡]	*

¹ In accordance with current CSA B149.1, *Natural Gas and Propane Installation Code*

² In accordance with the current ANSI Z223.1/NFPA 54, *National Fuel Gas Code*

[†] A vent shall not terminate directly above a sidewalk or paved driveway which is located between two single family dwellings and serves both dwellings.

[‡] Permitted only if veranda, porch, deck, or balcony is fully open on a minimum of two sides beneath the floor.

* Clearance in accordance with local installation codes and the requirements of the gas supplier

^a 3 feet (91cm) within a height of 15 feet (4.5m) above the meter / regulator assembly

^b 3 feet (91cm) above - if within 10 feet (3m) horizontally

4" X 6-5/8" RIGID PIPE CROSS REFERENCE CHART

Components from different Manufacturers may not be mixed. Not All Rigid Pipe components are available directly from FPI.

Description	Simpson Direct Vent Pro®	Selkirk Direct Temp™	American Metal Products® Amerivent Direct	Metal-Fab™ Sure Seal	Security Secure-Vent®	ICC Excel Direct
6" Pipe Length-Galvanized	46DVA-06	4DT-6	N/A	4D6	SV4L6	TC-4DL6
6" Pipe Length-Black	46DVA-06B	4DT-6B	N/A	4D6B	SV4LB6	TC-4DL6B
7" Pipe Length-Galvanized	N/A	N/A	4D7	N/A	N/A	N/A
7" Pipe Length-Black	N/A	N/A	4D7B	N/A	N/A	N/A
9" Pipe Length-Galvanized	46DVA-09	4DT-9	N/A	N/A	N/A	N/A
9" Pipe Length-Black	46DVA-09B	4DT-9B	N/A	N/A	N/A	N/A
12" Pipe Length-Galvanized	46DVA-12	4DT-12	4D12	4D12	SV4L12	TC-4DL1
12" Pipe Length-Black	46DVA-12B	4DT-12B	4D12B	4D12B	SV4LB12	TC-4DL1B
18" Pipe Length-Galvanized	46DVA-18	4DT-18	4D18	4D18	SV4L18	TC-4DL18
18" Pipe Length-Black	46DVA-18B	4DT-18B	4D18B	4D18B	SV4LB18	TC-4DL18B
24" Pipe Length-Galvanized	46DVA-24	4DT-24	4D24	4D24	SV4L24	TC-4DL2
24" Pipe Length-Black	46DVA-24B	4DT-24B	4D24B	4D24B	SV4LB24	TC-4DL2B
36" Pipe Length-Galvanized	46DVA-36	4DT-36	4D36	4D36	SV4L36	TC-4DL3
36" Pipe Length-Black	46DVA-36B	4DT-36B	4D36B	4D36B	SV4LB36	TC-4DL3B
48" Pipe Length-Galvanized	46DVA-48	4DT-48	4D48	4D48	SV4L48	TC-4DL4
48" Pipe Length-Black	46DVA-48B	4DT-48B	4D48B	4D48B	SV4LB48	TC-4DL4B
60" Pipe Length-Galvanized	46DVA-60	4DT-60	N/A	N/A	N/A	N/A
60" Pipe Length-Black	46DVA-60B	4DT-60B	N/A	N/A	N/A	N/A

Adjustable Length 3"-10"-Galvanized	N/A	N/A	N/A	4DAL	N/A	TC-4DLT
Adjustable Length 3"-10"-Black	N/A	N/A	N/A	4DALB	N/A	TC-4DLTB
Adjustable Length 7"-Galvanized	N/A	N/A	4D7A	N/A	N/A	N/A
Adjustable Length 7"-Black	N/A	N/A	4D7AB	N/A	N/A	N/A
Extension Pipe 8-1/2"-Galvanized	46DVA-08A	N/A	N/A	N/A	N/A	N/A
Extension Pipe 8-1/2"-Black	46DVA-08AB	N/A	N/A	N/A	N/A	N/A
Adjustable Length 12"-Galvanized	N/A	N/A	4D12A	N/A	SV4LA12	N/A
Adjustable Length 12"-Black	N/A	N/A	4D12A	N/A	SV4LBA12	N/A
Extension Pipe 16"-Galvanized	46DVA-16A	N/A	N/A	N/A	N/A	N/A
Extension Pipe 16"-Black	46DVA-16AB	N/A	N/A	N/A	N/A	N/A

45° Elbow-Galvanized	46DVA-E45	4DT-EL45	4D45L	N/A	N/A	TE-4DE45
45° Elbow-Black	46DVA-E45B	4DT-EL45B	4DT-EL45B	N/A	N/A	TE-4DE45B
45° Elbow Swivel-Galvanized	See 46DVA-E45	N/A	N/A	4D45L	SV4E45	N/A
45° Elbow Swivel-Black	See 46DVA-E45B	N/A	N/A	4D45LB	SV4EB45	N/A
90° Elbow-Galvanized	46DVA-E90	4DT-EL90S	4DT-EL90S	N/A	N/A	TE-4DE90
90° Elbow-Black	46DVA-E90B	4DT-EL90SB	4DT-EL90SB	N/A	SV4EBR90-1	TE-4DE90B
90° Elbow, Swivel-Galvanized	See 46DVA-E90	N/A	N/A	4D90L	SV4E90-1	N/A
90° Elbow, Swivel-Black	See 46DVA-E90B	N/A	N/A	4D90LB	SV4EB90-1	N/A
90° Starter Elbow, Swivel-Galvanized	N/A	N/A	N/A	4D90A	N/A	N/A
Adaptor*	N/A	N/A	N/A	4D90L	N/A	N/A

Ceiling Support	N/A	4DT-CS	4DFSP	4DSP	SV4SD	TE-4DE45
Cathedral Support Box	46DVA-CS	4DT-CSS	4DRSB	4DRS	SV4CSB	TE-4DE45B
Wall Support/Band	46DVA-WS	4DT-WS/B	4DWS	4DWS	SV4BM	N/A
Offset Support	46DVA-ES (N/A - FPI)	4DT-OS	N/A	N/A	SV4SU	N/A
Wall Thimble-Black	46DVA-WT	4DT-WT	4DWT	4DWT	SV4RSM	TE-4DE90
Wall Thimble Support/Ceiling Support	46DVA-DC	N/A	N/A	N/A	SV4PF	TE-4DE90B
Firestop Spacer	46DVA-FS	4DT-FS	4DFSP	4DFS	SV4BF	N/A
Trim Plate-Black	N/A	4DT-TP	4DFPB	4DCP	SV4LA	N/A

Description	Simpson Direct Vent Pro®	Selkirk Direct Temp™	American Metal Products® Amerivent Direct	Metal-Fab™ Sure Seal	Security Secure-Vent®	ICC Excel Direct
Attic Insulation Shield 12"	46DVA-IS N/A @ FPI	N/A	4DAIS12	N/A	SV4RSA	N/A
Attic Insulation Shield - Cold Climates 36"	N/A	N/A	4DAIS12	N/A	N/A	TM-4AS

Basic Horizontal Termination Kit (A)	Disc.	4DT-HKA	4DHTK2	4DHTKA	SV-SHK	N/A
Horizontal Termination Kit (B)	46DVA-KHA (Changed Components)	4DT-HKB	4DHTK1	4DHTKB	SV-HK	N/A
Vertical Termination Kit	Disc.	4DT-VKC	4DHTK	4DHTK	SV-FK	N/A

High Wind Vertical Cap	46DVA-VCH	N/A	N/A	N/A	N/A	TM-4VT
High Wind Horizontal Cap	46DVA-HC	N/A	N/A	N/A	N/A	TM-4DHT
Horizontal Square Termination Cap	See 46DVA-HC	4DT-HHC	4DHC	4DHT	SV4CHC-1	TM-4HT
Vertical Termination Cap	46DVA-VC	4DT-HVC	4DVC	4DVT	SV4CGV-1	TM-4VT
Storm Collar	46DVA-08A	4DT-SC	4DSC	4DSC	SV4FC	TM-SC

Adjustable Flashing 0/12-6/12	46DVA-F6	4DT-ST14	4D12S	4DST14	SV4STC14	TF-4FA
Adjustable Flashing 6/12-12/12	46DVA-FLA	4DT-ST36	4D36S	4DST36	SV4STC36	TF-4FB

Vinyl Siding Standoff	46DVA-VSS	4DT-VS	N/A	4DVS	SV4VS	TM-VSS
Vinyl Siding Shield Plate	N/A	4DT-VSP	N/A	N/A	SV4VS	N/A

Snorkel Termination 14"	46DVA-SNKL	N/A	N/A	N/A	N/A	TM-4ST14
Snorkel Termination 36"	N/A	N/A	N/A	N/A	N/A	TM-4ST36

Restrictor Disk	N/A	N/A	N/A	N/A	N/A	TM-4DS
Extended Vertical Termination Cap	N/A	N/A	N/A	N/A	N/A	N/A
Chimney Conversion Kit A (USA only)	46DVA-KCA	N/A	N/A	N/A	N/A	TM-4CA6
Chimney Conversion Kit B (USA only)	46DVA-KCB	N/A	N/A	N/A	N/A	TM-4CA7
Chimney Conversion Kit C (USA only)	46DVA-KCC	N/A	N/A	N/A	N/A	TM-4CA8
Chimney Conversion Kit Masonry (USA only)	46DVA-KMC	N/A	N/A	N/A	N/A	N/A
Wall Firestop	46DVA-WFS	N/A	N/A	N/A	N/A	TM-4TR
Colinear Flex Connectors	46DVA-ADF	N/A	N/A	N/A	N/A	N/A

FPI			
946-506/P	Vent Guard (Optional) for AstroCap	946-205	Vinyl Siding Shield for Riser Vent Terminal
		946-208/P	Vent Guard (Optional) for Riser Vent Terminal
640-530/P	Riser Vent Terminal	946-523/P	AstroCap Horizontal Cap
946-605	Starter Collar Increaser 4" x 6-5/8" to 5" x 8"	946-206	Vinyl Siding Standoff for AstroCap

Note: When using Metal-Fab Sure Seal Rigid Piping - please note that the Adaptor (4DDA) must be used in conjunction with FPI Rigid Pipe Adaptor

Offset Pipe Selection: Use this table to determine offset pipe lengths.			
Pipe Length (L)	4" x 6-5/8" Venting		
	Run (X)	Rise (Y)	
0" (0mm)	4-7/8" (124mm)	13-7/8" (340mm)	For specific instructions on venting components - visit the manufacturers website listed below. Simpson Direct Vent Pro: www.duravent.com Selkirk Direct-Temp: www.selkirkcorp.com American Metal Products: www.americanmetalproducts.com Metal-Fab Sure Seal: www.mtfab.com Security Secure Vent: www.securitychimneys.com Industrial Chimney Company: www.icc-rsf.com
6" (152mm)	8" (203mm)	16-1/2" (419mm)	
9" (229mm)	10-1/8" (257mm)	18-5/8" (473mm)	
12" (305mm)	12-1/4" (311mm)	20-3/4" (527mm)	
24" (610mm)	20-5/8" (524mm)	29-1/8" (740mm)	
36" (914mm)	29" (737mm)	37-1/2" (953mm)	
48" (1219mm)	37-7/16" (951mm)	45-15/16" (1167mm)	

Note: Horizontal runs of vent must be level, or have a 1/4" rise for every 1 foot of run towards the termination.
Never allow the vent to run downward - this could cause high temperatures and may present a possible fire hazard.

RIGID PIPE VENTING SYSTEMS *Horizontal or Vertical Terminations*

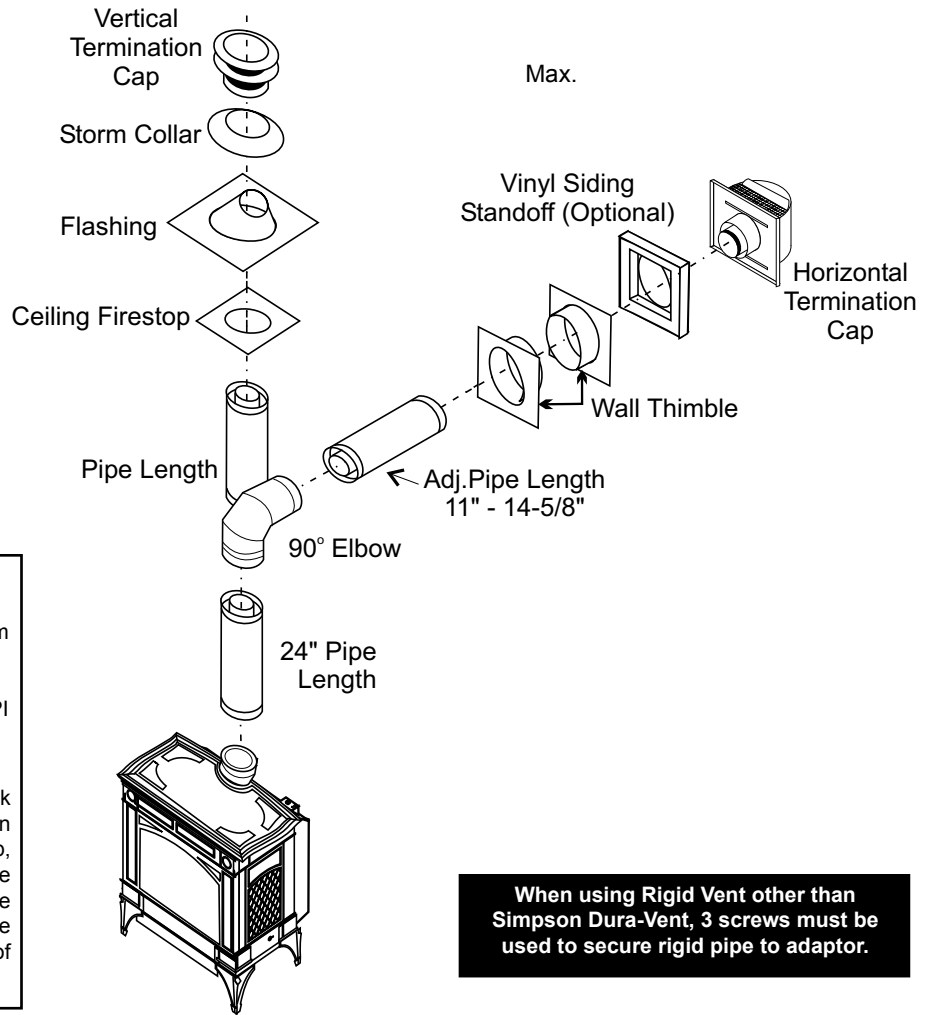
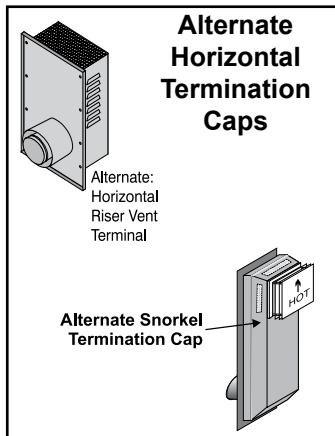

WARNING:

Do not combine venting components from different venting systems.

However use of the the AstroCap™ and FPI Riser is acceptable with all systems.

This product has been evaluated by Intertek for using a Rigid Pipe Adaptor in conjunction with Duravent Direct-Vent, Selkirk Direct-Temp, Ameri Vent Direct venting and Security Secure Vent systems. Use of these systems with the Rigid Pipe adaptor is deemed acceptable and does not affect the Intertek WHI listing of components.

When using Rigid Vent other than Simpson Dura-Vent, 3 screws must be used to secure rigid pipe to adaptor.

The FPI AstroCap™ and FPI Riser Vent terminal are certified for installations using FPI venting systems as well as Simpson Dura-Vent® Direct Vent, American Metal Products Ameri Vent Direct Vent, Security Secure Vent®, Selkirk Direct-Temp. AstroCap™ is a proprietary trademark of FPI Fireplace Products International Ltd. Dura-Vent® and Direct Vent are registered and/or proprietary trademarks of Simpson Dura-Vent Co. Inc.

Horizontal Venting with Two (2) 90° Elbows

One 90° elbow = Two 45° elbows.

Option	V	H + H1	
A)	1' Min.	3' Max.	With these options, maximum total pipe length is 30 feet with minimum of 6 feet total vertical and maximum 8 feet total horizontal. Please note minimum 1 foot between 90° elbows is required.
B)	2' Min.	4' Max.	
C)	3' Min.	5' Max.	
D)	4' Min.	6' Max.	
E)	5' Min.	7' Max.	
F)	6' Min.	8' Max.	
Lengths do not include elbow indicated			
Vent restrictor position A (fully open), refer to the "Vent Restrictor Position" section.			

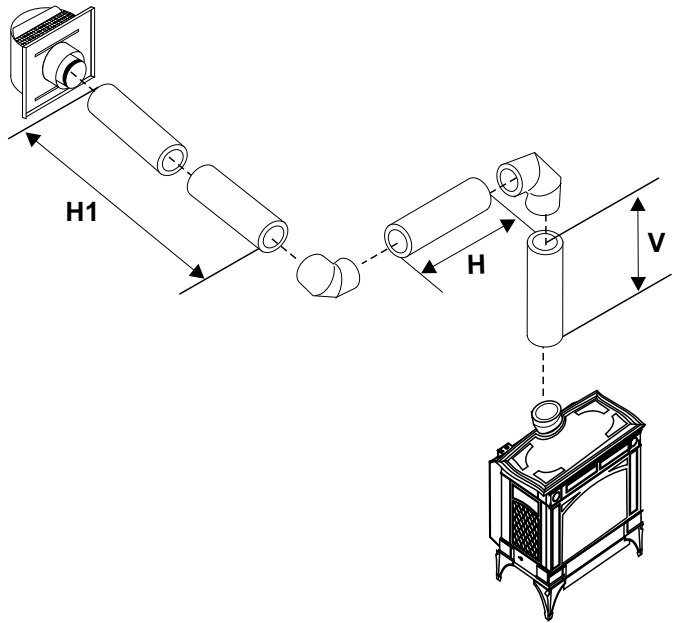

Horizontal Venting with Two (2) 90° Elbows

One 90° elbow = Two 45° elbows.

Option	H	V	H + H1	
A)	1' Max.	1' Min.	3' Max.	With these options, max. total pipe length is 30 feet with min. of 8 feet total vertical and max. 8 feet total horizontal. Please note min. 1 foot between 90° elbows is required.
B)	2' Max.	2' Min.	5' Max.	
C)	3' Max.	4' Min.	6' Max.	
D)	4' Max.	6' Min.	7' Max.	
E)	5' Max.	8' Min.	8' Max.	
Lengths do not include elbow indicated				
Vent restrictor position A (fully open), refer to the "Vent Restrictor Position" section.				

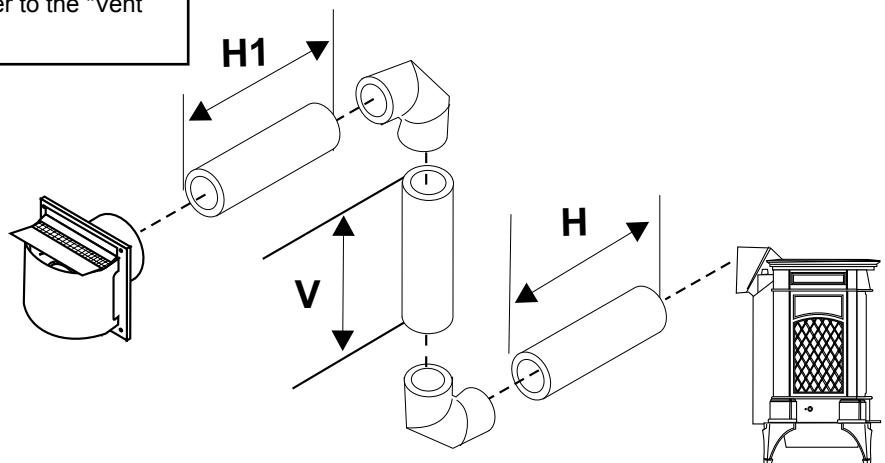

INSTALLATION

Vertical Venting with Two (2) 90° Elbows

One 90° elbow = Two 45° elbows.

Option	V	H	V + V1	With these options, max. total pipe length is 30 feet with min. of 6 feet total vertical and max. 8 feet total horizontal. Please note min. 1 foot between 90° elbows is required.
A)	1' Min.	4' Max.	2' Min.	
B)	2' Min.	5' Max.	3' Min.	
C)	3' Min.	6' Max.	4' Min.	
D)	4' Min.	7' Max.	5' Min.	
E)	5' Min.	8' Max.	6' Min.	

Lengths do not include elbow indicated

Vent restrictor position A (fully open), refer to the "Vent Restrictor Postion" section.

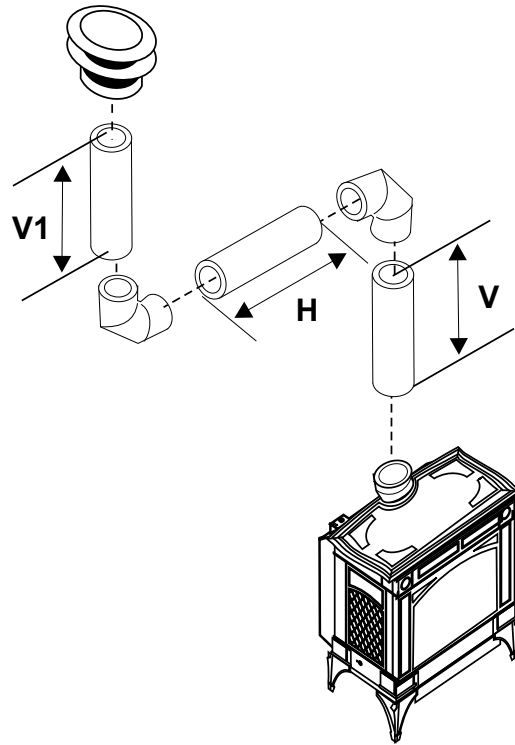

Vertical Venting with Two (2) 90° Elbows

Option H + H1 V

One 90° elbow = Two 45° elbows.

A)	2' Max.	2' Min.	With these options, max. total pipe length is 30 feet with min. of 6 feet total vertical and max. 6 feet total horizontal. Please note min. 1 foot between 90° elbows is required.
B)	3' Max.	3' Min.	
C)	4' Max.	4' Min.	
D)	5' Max.	5' Min.	
E)	6' Max.	6' Min.	

Lengths do not include elbow indicated

Vent restrictor position A (fully open), refer to the "Vent Restrictor Postion" section.

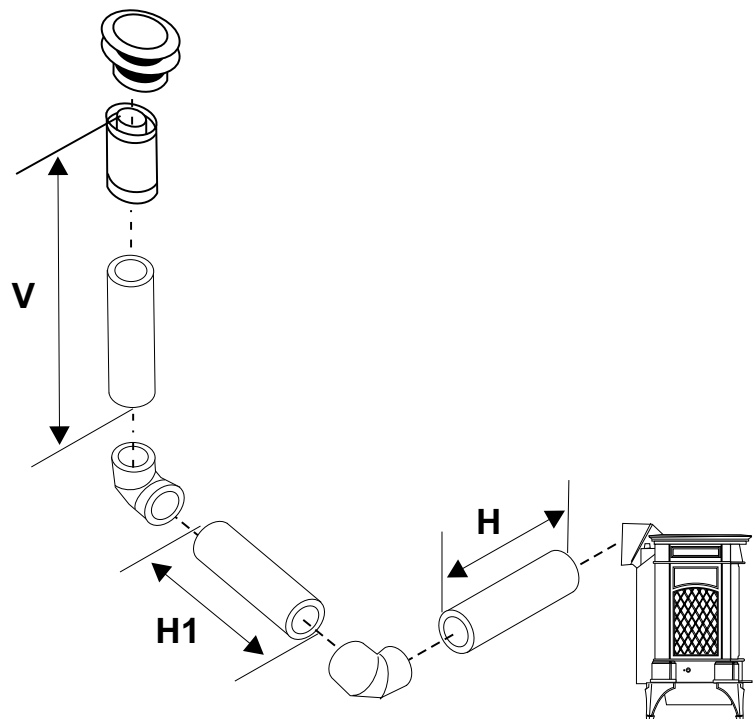

VENTING ARRANGEMENTS

Horizontal Terminations for All Venting Systems

The shaded areas in the diagram below show all allowable combinations of vertical runs with horizontal terminations. Maximum one 90° elbow (two 45° elbows equal one 90° elbow).

Propane and Natural Gas: Residential, Manufactured and Mobile Homes Installations

May be installed in Manufactured (Mobile) Homes after first sale.

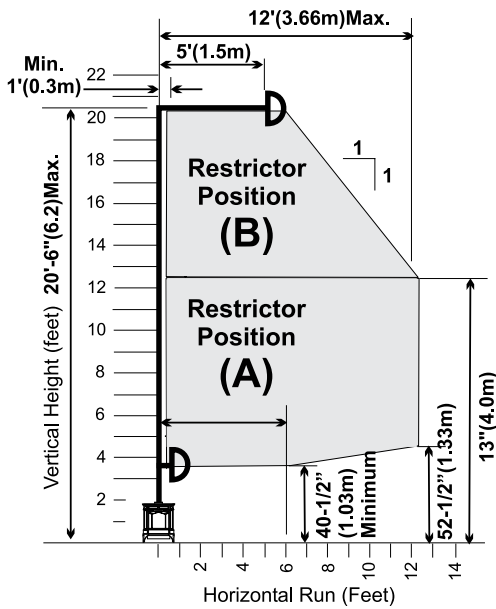

Vertical Terminations Systems for Residential Manufactured and Mobile Homes

The shaded area in the diagram below shows all allowable combinations of straight vertical and offset to vertical runs with vertical terminations. Maximum two 45° elbows.

If the vent is ENCLOSED in a chase (min. size 9" x 9") maintain a 1-1/4" clearance to combustibles.

May be installed in Manufactured (Mobile) Homes after first sale.

Offset to Vertical Terminations

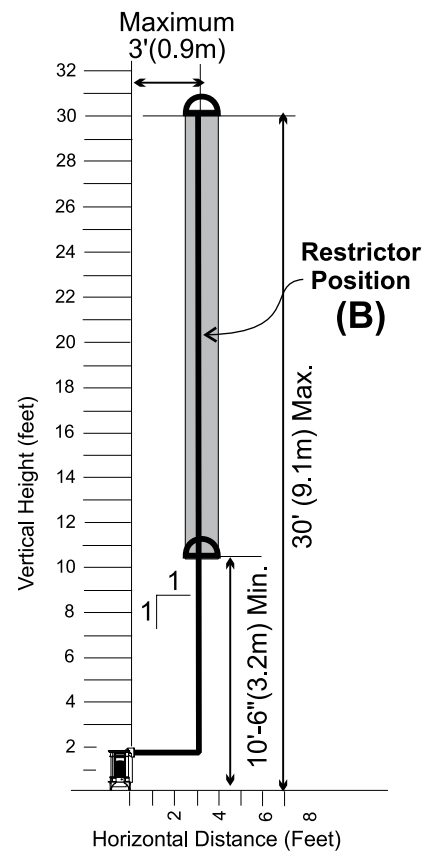
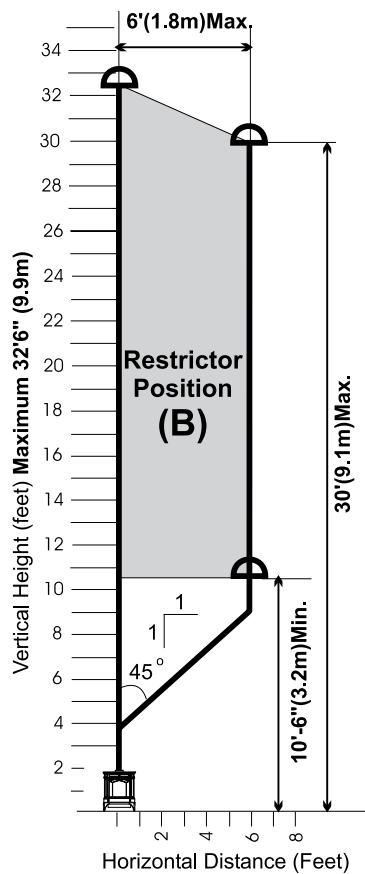

Venting Arrangements - Horizontal Terminations

The two diagrams show all allowable combinations of straight horizontal termination with one 45° elbow off the unit. Restrictor position "A".

12" max. w/AstroCap or Simpson Duravent Horizontal Square Termination Cap.

24" max. w/FPI Riser or Snorkel Termination Cap.

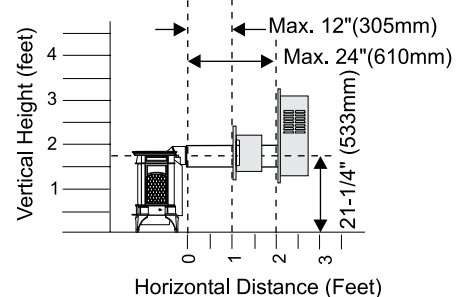
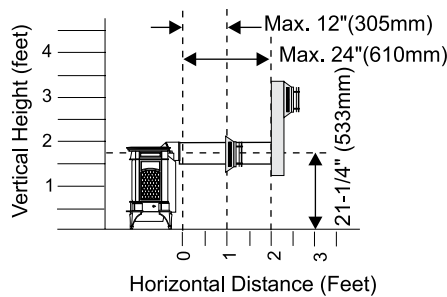

VERTICAL TERMINATION WITH CO-LINEAR FLEX SYSTEM

THE APPLIANCE MUST NOT BE CONNECTED TO A CHIMNEY FLUE SERVING A SEPARATE SOLID FUEL BURNING APPLIANCE.

This appliance is designed to be attached to two 3" (76mm) co-linear aluminium flex running the full length of the chimney. See the Venting Arrangements chart below for minimum and maximum flue lengths. See chart below for minimum distances from roof. Periodically check that the vent is unrestricted.

Masonry chimneys may take various contours which the flexible liner will accommodate. However, **keep the flexible liner as straight as possible**, avoid unnecessary bending.

The Air Intake pipe must be attached to the inlet air collar of the termination cap.

Required Parts:

Part #	Description
946-529	Co-linear DV Vertical Termination Cap
948-305	3" Flex - 35 ft.
946-563	Co-Axial to Co-Linear Adapter Kit which contains the following: Co-linear Flex Adapter (270-585) Outer Pipe (946-257) Inner Pipe Adapter (946-219)

Alternate Approved Caps

980	Vertical Termination Cap
991	High Wind Cap
923GK	3" Co-linear Adapter with flashing

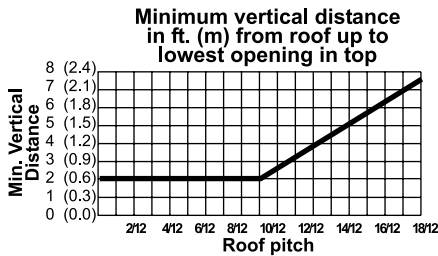

Venting Arrangements - Vertical Terminations with Co-linear Flex System for both Residential & Manufactured Homes into Masonry Fireplaces

The shaded area in the diagram shows the allowable vertical terminations.

Straight Vertical Terminations

Vent Restrictors set at fully closed, Position "B"

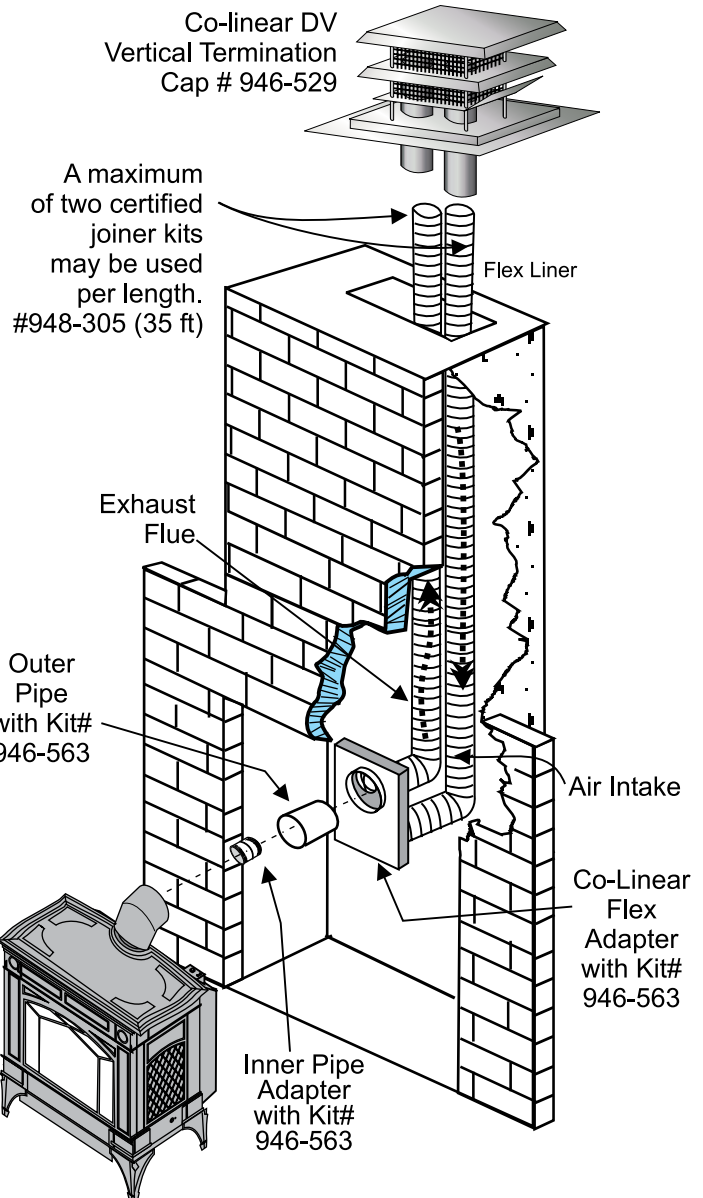
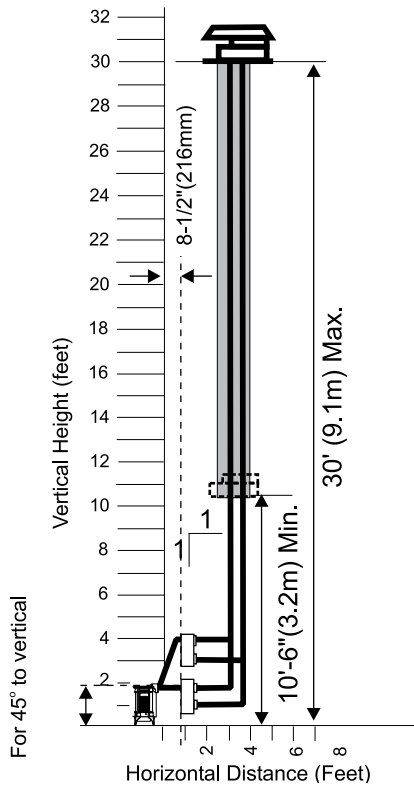

DV STOVE HORIZONTAL VENT KIT

DV 2 ft. Stove Vent Kit (Part # 946-116) and DV 4 ft. Stove Vent Kit (946-216) includes all the parts needed to install the H15-1 Direct Vent unit with up & out horizontal and vertical vent dimensions. For installations that require longer vertical and/or horizontal vents use the Dura-Vent system as shown in the "Dura-Vent Termination Kit" and "Dura-Vent Venting Components" sections.

- | Qty. | Description |
|--------|---|
| 1) 1 | Rigid Pipe Section (Kit # 946-116: 2 ft. (1.2m) length, Kit # 946-216: 4 ft. (1.2m) length), 6-1/2" (165mm) inside diameter |
| 2) 1 | Flex Liner, compressed aluminium 2 ply liner, 4" (102mm) inside diameter |
| 3) 4 | spring spacers |
| 4) 1 | 90 deg. Elbow |
| 5) 1 | Adjustable pipe section 13-1/2" to 24" (343mm x 610mm), 2 pcs. |
| 6) 1 | Thimble Cover |
| 7) 1 | Wall Thimble (2 pcs.) |
| 8) 1 | Adapter |
| 9) 1 | AstroCap Termination Cap |
| 10) 2 | Trim Collars |
| 11) 1 | tube of Mill-Pac, high temperature sealant |
| 12) 12 | Screws, #8 x 1/2" Self tapping, Stainless Steel |
| 13) 14 | Screws, #8 x 1/2" Self tapping, Black |
| 14) 4 | Screws #8 x 1-1/2" Drill Point, Black |
| 15) 4 | Screws #8 x 1-1/2" Drill Point, Stainless Steel |
| 16) 8 | Wood screws #8 x 1" |

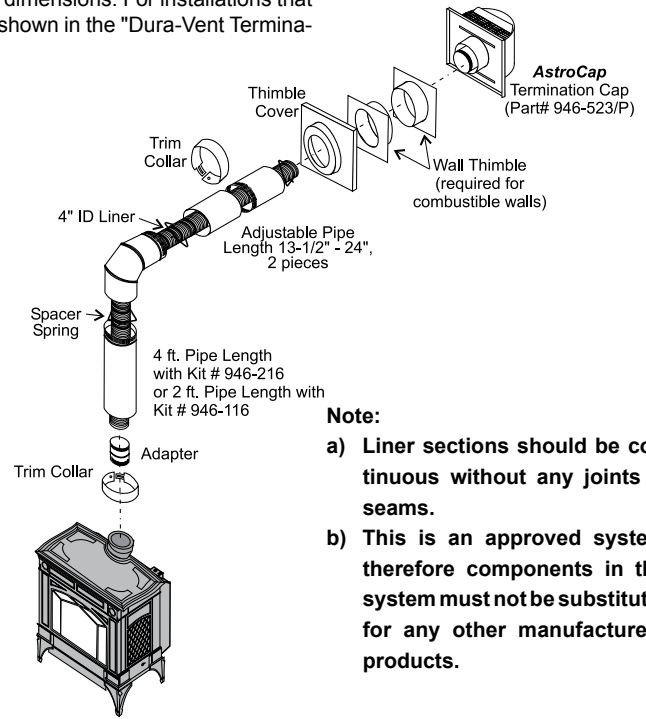

Note:

- Liner sections should be continuous without any joints or seams.
- This is an approved system, therefore components in this system must not be substituted for any other manufacturer's products.

DV STOVE HORIZONTAL VENT KIT (#946-116 & #946-216) INSTALLATION

Review the following sequence of instructions which are typical of most installations. The sequence may vary depending on wall thickness. Refer to the "Exterior Vent Terminal Locations" and "Rigid Pipe Venting Systems" sections for vent location and clearance dimensions, and the "Vent Restrictor Position" for the correct positioning.

- Set the unit in its desired location. Check to determine if wall studs will be in the way of the venting system, adjust location until all clearances are met and there are no obstructions.

Note: A 1-1/2" (38mm) clearance around the outer pipe must be maintained except that only a 1" (25mm) clearance is needed at the termination end.

IMPORTANT:

Do not locate termination hood where excessive snow or ice buildup may occur. Be sure to check vent termination area after snow falls, and clear to prevent accidental blockage of venting system. When using snow blowers, make sure snow is not directed towards vent termination area.

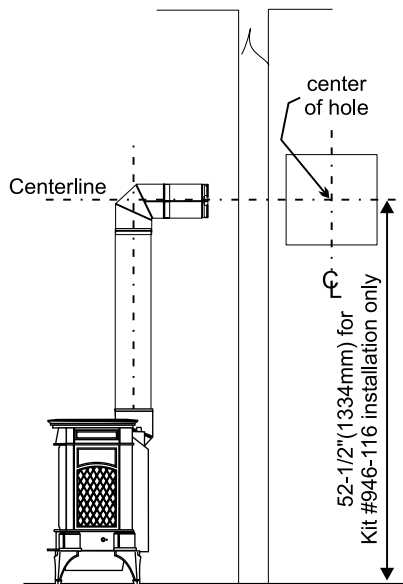

- Assemble a trial fit to determine the vertical center-line for the vent termination.

- Cut a 9-1/2" x 9-1/2" (241mm x 241mm) square hole on both the interior and exterior wall.

- Install wall thimbles on both interior and exterior wall with 4 wood screws (#8 x 1") per thimble.
- Attach the 2 piece adjustable pipe section to the vent terminal and slide into position from the exterior. **The larger diameter end of the adjustable pipe goes to the vent terminal.**

- Install the 90° elbow onto the adjustable pipe to determine the vertical centerline.

Note: if the centerline cannot be met, the adjustable sections will have to be cut.

- Cut the 4 ft. section of rigid pipe to length. Attach the 45° elbow to the rigid pipe, and ensure that the pipe length when cut (with the 45° elbow) will seat onto both the starter collar and the 90° elbow. **Crimped section of rigid pipe seats into the 90° elbow. Only cut the uncrimped side of pipe.**

Dismantle all pipe sections including vent terminal.

RESIDENTIAL AND MANUFACTURED HOMES / MOBILE HOMES MINIMUM HORIZONTAL TERMINATION INSTALLATIONS

Planning Your Venting Installation

See the "Exterior Vent Terminal Locations" section for requirements.

When planning your installation, it will be necessary to select the proper length of vent pipe for your particular requirements. Determine the minimum clearance to combustibles from the rear of the unit to the wall. It is also important to note the wall thickness. Before cutting the vent hole through the wall ensure that ALL vent and termination clearances (Refer to the "Exterior Vent Terminal Locations" section) will be met.

*If this is an outside corner, the minimum distance between the vent and the outside corner is 6" (15cm). See "F" on the diagram in the "Exterior Vent Terminal Locations" section.

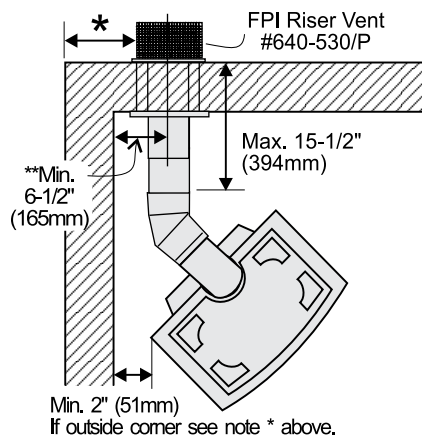
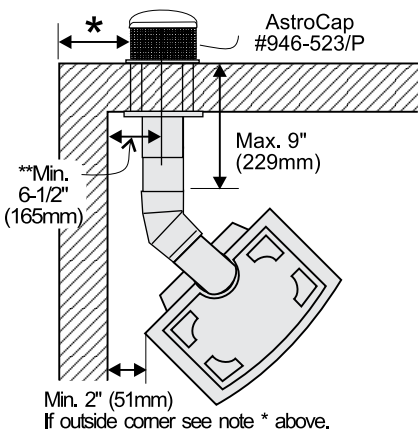

NOTE: Ensure compliance with the outside vent terminal location before cutting hole as both dimensions must be met.

You will require the following components with your new Hampton® Direct Vent Freestanding Gas Stove. Please review your product to make sure you have everything you need. In the event that you are missing any part, contact your dealer. Decorative brass or chrome trim kits are available from Simpson Dura-Vent for their wall thimbles, as well as a square wall thimble cover.

Note: These are the minimum pieces required. Other parts may be required for your particular installation.

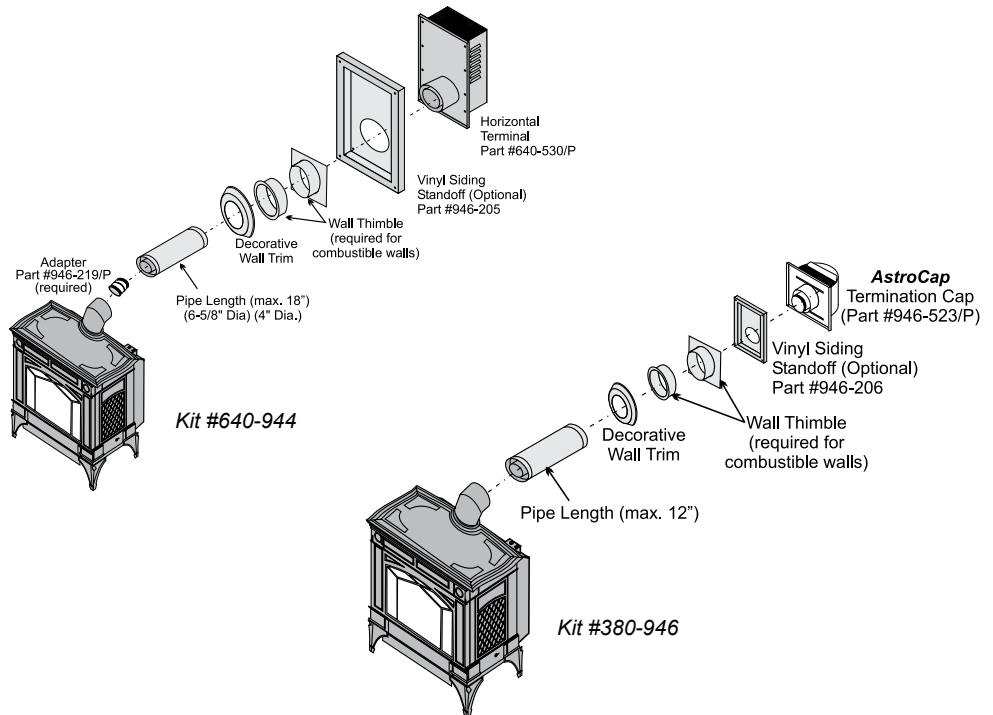

Minimum components for a Horizontal Installation:

- 640-944** Horizontal Termination Kit which includes:
- 1 6-5/8" Dia. x 18" Black Pipe
 - 1 4" Dia. x 18" Aluminum Vent
 - 1 946-202 Wall Penetration Heat Shield (Wall Thimble) (2 pcs)
 - 1 640-530/P Riser Vent Terminal
 - 1 640-545/P Decorative Wall Trim (Black)
 - 1 948-128 Tube Mill-Pac Screws

- 380-946** Horizontal Termination Kit which includes:
- 1 6-5/8" Dia. x 12" Black Pipe
 - 1 4" Dia. x 12" Aluminum Vent
 - 1 946-202 Wall Penetration Heat Shield (Wall Thimble) (2 pcs)
 - 1 946-523/P AstroCap
 - 1 640-545/P Decorative Wall Trim (Black)
 - 1 948-128 Tube Mill-Pac Screws

Optional Components:

- | | | | |
|-----------|---|-----------|----------------------------------|
| 946-204 | 45° Elbow - 6-5/8" Black pipe and 4" Aluminum Vent | 946-523/P | AstroCap |
| 946-205 | Vinyl Siding Shield for Riser Vent Terminal | 946-206 | Vinyl Siding Standoff (AstroCap) |
| 946-208/P | Vent Guard (Riser Vent Terminal) Square Wall Thimble Cover* Snorkel Termination (36") Snorkel Termination (14") Wall Penetration Heat Shield* | 946-506/P | Vent Guard (AstroCap) |

* Simpson Dura-Vent Components

DURA-VENT TERMINATION KIT

Installation

There are two basic types of Dura-Vent Direct Vent System installations: horizontal termination and vertical termination. Confirm the maximum horizontal run and maximum vertical rise from the diagrams in the "Rigid Pipe Venting Systems" section.

When planning your installation, it will be necessary to select the proper length of vent pipe for your particular requirements. For horizontal installations, determine the minimum clearance from the rear of the unit to the wall. It is also important to note the wall thickness. (The wall thimble is suitable for 2 x 4 or 2 x 6 wall construction.)

Planning Your Dura-Vent tion.) Select the amount of vertical rise desired for "vertical-to-horizontal" type installations.

Warning: Always maintain required clearances (air spaces) to nearby combustibles to prevent a fire hazard. Do not fill air spaces with insulation.

The minimum clearance requirements between the outer wall of the vent pipe and nearby combustible surfaces is 1-1/4 inch. Be sure to check the vent termination clearance requirements from decks, windows, soffits, gas regulators, air supply inlets and public walkways as specified

in the "Exterior Vent Terminal Locations" section and in your local building codes.

To determine the length of vent pipe required for vertical installations, measure the distance from the unit flue outlet to the ceiling, the ceiling thickness, the vertical rise in an attic or second storey, and allow for sufficient vertical height above the roof line.

For multi-storey applications, fire stops are required at each floor level. If an offset is needed, additional pipe, elbows and supports will be required.

Do not exceed the maximum number of elbows. One 90° for horizontal terminations and two 45° for vertical termination.

You will require the following components with your new Direct Vent Freestanding Gas Stove.

Dura-Vent Vertical Termination Installation

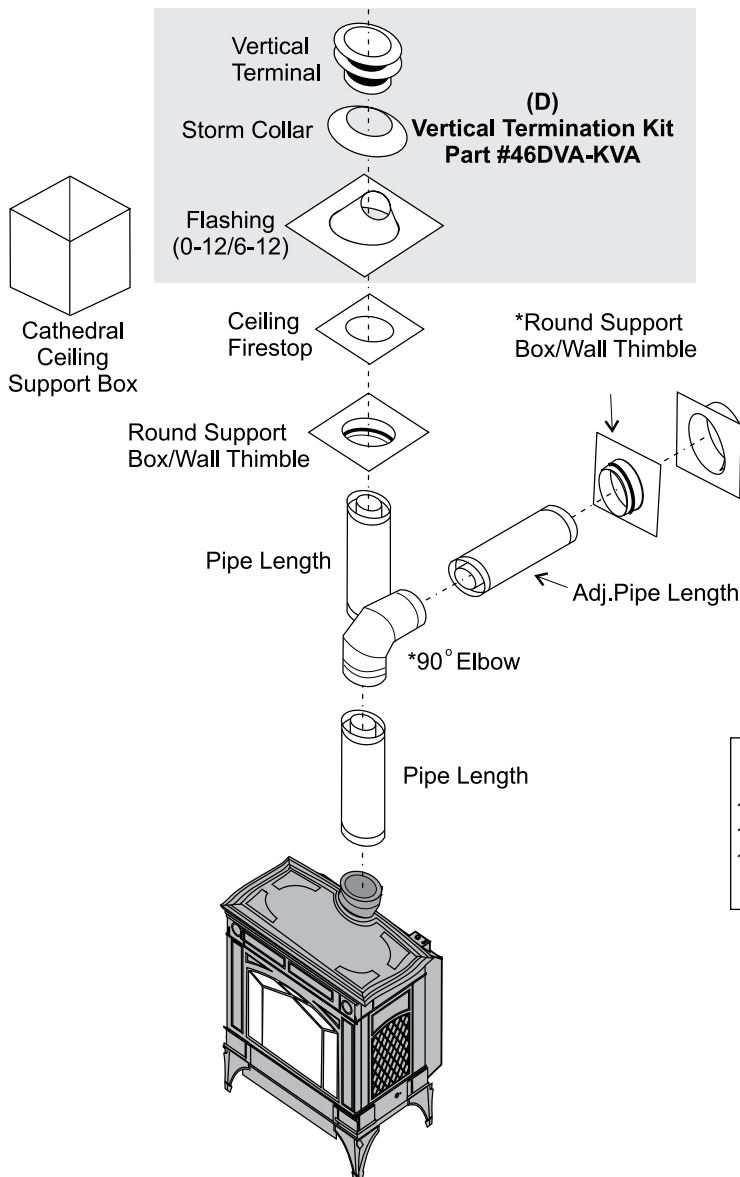

Dura-Vent Horizontal Termination Installation

(A)
*Horizontal Termination Kit
Part # 46DVA-KHA



- Basic Horizontal Kit**
- 1 90° Elbow
 - 1 Wall Thimble Cover
 - 1 Horiz. Sq. Term. Cap

Alternate Horizontal Termination Caps

AstroCap
Part# 946-523/P

Alternate Horizontal Riser Vent Terminal
Part# 640-530/P

The FPI AstroCap™ is certified for installations using FPI venting systems as well as Simpson Dura-Vent® and Direct Vent.

The FPI AstroCap™ is a proprietary trademark of FPI Fireplace Products International Ltd.

Dura-Vent® and Direct Vent are registered and/or proprietary trademarks of Simpson Dura-Vent Co. Inc.

Please review your product to make sure you have everything you need. In the event that you are missing any part, contact your dealer.

Note: These are the minimum pieces required. Other parts may be required for your particular installation. See above for a list of vent parts.

If installing termination on a siding covered wall, a vinyl siding standoff or furring strips can be used in order to ensure that the termination is not recessed into siding.

The vinyl siding standoff is required for walls with vinyl siding.

Minimum components for a Dura-Vent Horizontal Installation:

- A) Dura-Vent Horizontal Termination Kit
- B) Wall Thimble (required for combustible walls)

Minimum components for a Dura-Vent Vertical Termination:

- D) Dura-Vent Vertical Termination Kit. See above for pipe lengths.

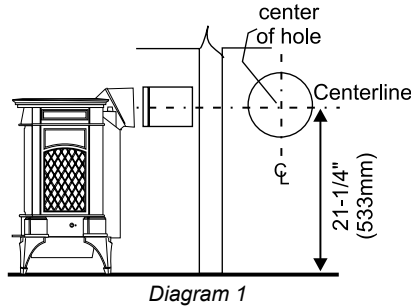

Diagram 1

- a) The horizontal run of vent should have a 1/4 inch rise for every 1 foot of run towards the termination. Never allow the vent to run downward. This could cause high temperatures and may present the possibility of a fire.
- b) The location of the horizontal vent termination on an exterior wall must meet all local and national building codes, and must not be blocked or obstructed. Refer to the "Exterior Vent Terminal Locations" section.
- c) **Snorkel Terminations:**
For installations requiring a vertical rise on the exterior of the building, 14-inch and 36-inch tall Snorkel Terminations as shown in Diagram 2 are available, as well as the standard Riser Vent. Follow the same installation procedures as used for standard Horizontal Termination. NEVER install the snorkel upside down.

Below Grade Snorkel Installation

If the Snorkel Termination must be installed below grade, i.e. basement application, proper

*Diagram 2a: As specified in CGA B149 Installation Code. Local codes or regulations may require different clearances.

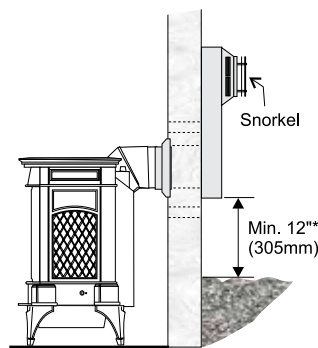

Diagram 2a

HORIZONTAL TERMINATIONS

- 1) Set the unit in its desired location. Check to determine if wall studs are in the way when the venting system is attached. If this is the case, you may want to adjust the location of the unit.
- 2) Assemble the desired combination of pipe and elbow to the appliance adapter with pipe seams oriented down. Offset the pipe seams as double seams in one place will cause the outer pipe to take an oval shape. Kit comes complete with 18" of straight vent - 6-5/8" dia. black outer pipe and 4" dia. inner vent.
- 3) With the pipe attached to the stove, slide the stove into its correct location, and mark the wall for a 9-1/2" (inside dimensions) round hole. The center of the round hole should line up with the centerline of the horizontal pipe, as shown in diagram 1. Cut and frame the 9-1/2" round hole in the exterior wall where the vent will be terminated. If the wall being penetrated is constructed of non-combustible material, i.e. masonry block or concrete, a 7" diameter hole is acceptable.

Note:

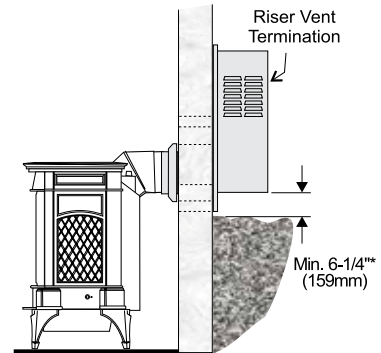

Diagram 2b

NOTE: For Snorkel terminations in ABOVE grade installations, follow national or local code requirements.

drainage must be provided to prevent water from entering the Snorkel Termination. Do not attempt to enclose the Snorkel within the wall, or any other type of enclosure.

- 4) Install wall penetration heat shield in the center of the 9-1/2" round hole and attach with wood screws. The four wood screws provided should be replaced with appropriate fasteners for stucco, brick, concrete, or other types of sidings. Diagram 3.
- 5) If installing termination on a siding covered wall, a vinyl siding standoff or furring strips must be used to ensure that the termination is not recessed into the siding. Diagram 3.
- 6) Take the Riser Vent terminal and separate the Backing Plate from the Riser Vent Front by removing 8 screws as shown in diagram 4.
- 7) Install the Backing Plate into the wall penetration heat shield and attach using 4 screws. Dia. 4.
- 8) Connect all pipe sections to unit and install into wall:

- a) Measure pipe length required and cut to length.

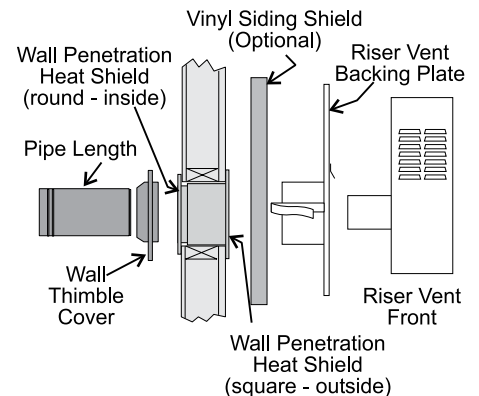

Diagram 3

INSTALLATION

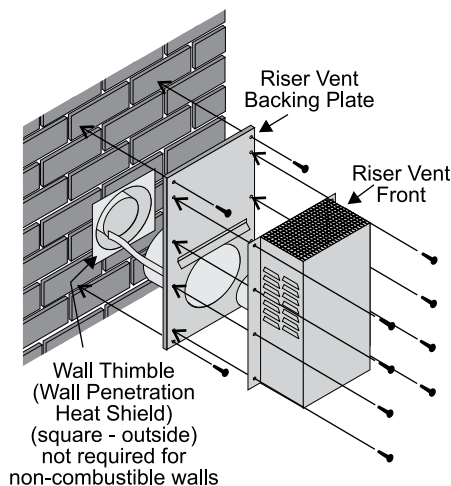
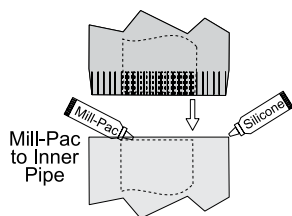

Diagram 4

Hint: use the cut end of the 6-5/8" dia. outer pipe at the vent terminal end.

- b) Push the pipe sections completely together, the minimum pipe overlap is 1-1/4". Secure all outer pipe joints by using at least two screws. Locate the screws at the bottom of the pipe so that the screw heads are hidden on the final installation.

Note: For best results and optimum performance with each approved venting system, it is highly recommended to apply "Mill-Pac" sealant (supplied) to every inner pipe connection. Failure to do so may result in drafting or performance issues not covered under warranty. Silicone (red RTV) is optional.



- c) Before connecting the vent pipe to the vent termination, slide the black decorative wall thimble cover over the vent pipe, then slide the Wall Penetration Heat Shield (Part # 946-202) over the vent pipe. Dia. 3.

- d) Slide the appliance and vent assembly towards the wall carefully inserting the vent pipe into the riser vent terminal assembly. It is important that the vent pipe extends into the Riser Vent Backing Plate a sufficient distance so as to result in a minimum pipe overlap of 1-1/4 inches. Secure the connection between the vent pipe and the vent cap by attaching the two sheet metal strips extending from the Riser Vent Backing Plate into the outer wall of the vent pipe. Use two aluminum screws provided to connect the strips to the pipe section. Bend any remaining portion of the sheet metal strip back towards the vent cap and cut off any excess, it will be concealed by the decorative wall thimble cover. See diagram 5.

- 8) Slide the decorative wall thimble up to the wall

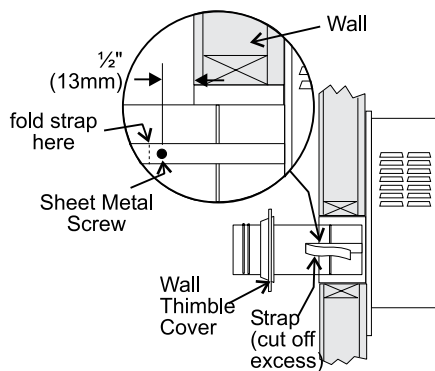

Diagram 5

surface being careful not to scratch the paint. See diagram 5.

- 9) Back outside: Apply sealant to the 4" inner flue and slide the Riser Vent Front into the Backing Plate and fasten with 8 screws.

IMPORTANT: When connecting the pipe to the Riser Vent, apply Mill-Pac to the inner pipe on the Riser Vent Terminal, around the bead. Ensure that the vent pipe is pushed past the bead for a secure fit.

- 10) Seal around the outer edge of the Riser Vent Backing Plate.

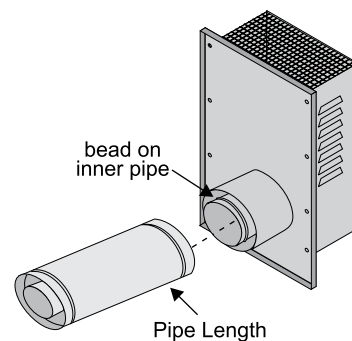

VERTICAL TERMINATIONS

- 1) Maintain the 1-1/4" clearances (air spaces) to combustibles when passing through ceilings, walls, roofs, enclosures, attic rafter, or other nearby combustible surfaces. Do not pack air spaces with insulation. Check the "Venting Arrangement" section for the maximum vertical rise of the venting system and the maximum horizontal offset limitations.
- 2) Set the gas appliance in its desired location. Drop a plumb bob down from the ceiling to the position of the appliance flue exit, and mark the location where the vent will penetrate the ceiling. Drill a small hole at his point. Next, drop a plumb bob from the roof to the hole previously drilled in the ceiling, and mark the spot where the vent will penetrate the roof. Determine if ceiling joists, roof rafters or other framing will obstruct the venting system. You may wish to relocate the appliance or to offset, as shown in diagram 8 to avoid cutting load bearing members.

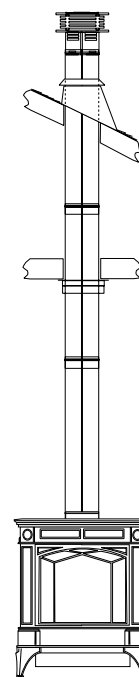

Diagram 7

- 3) To install the Round Support Box/Wall Thim-

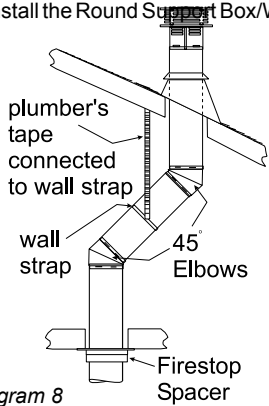

Diagram 8

ble in a flat ceiling, cut a 10 inch square hole in the ceiling centred on the hole drilled in Step 2. Frame the hole as shown in diagram 9.

- 4) Assemble the desired lengths of black pipe

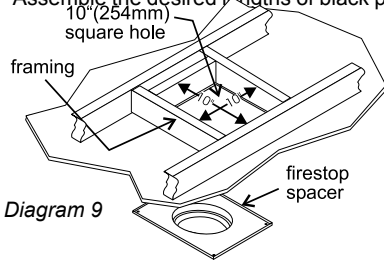
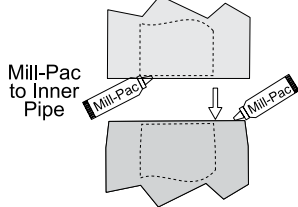

Diagram 9

and elbows necessary to reach from the appliance adapter up through the Round Support Box. Insure that all pipes and elbow connections are in the fully twist-locked position and sealed.

- 5) Cut a hole in the roof centred on the small



Note: For best results and optimum performance with each approved venting system, it is highly recommended to apply "Mill-Pac" sealant (supplied) to every inner pipe connection. Failure to do so may result in drafting or performance issues not covered under warranty. Silicone (red RTV) is optional.

drilled hole placed in the roof in Step 2. The hole should be of sufficient size to meet the minimum requirements for clearance to combustibles of 1-1/4". Slip the flashing under the shingles (shingles should overlap half the flashing) as per diagram 10.

- 6) Continue to assemble pipe lengths.

Note: If an offset is necessary in the attic

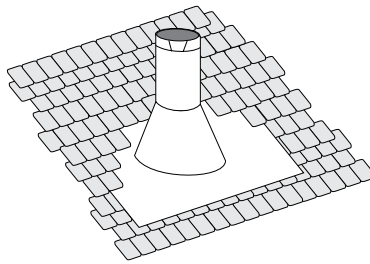

Diagram 10: The upper half of the flashing is installed under the roofing material and not nailed down until the chimney is installed. This allows for small adjustments.

to avoid obstructions, it is important to support the vent pipe every 3 feet, to avoid excessive stress on the elbows, and possible separation. Wall straps are available for this purpose. See diagram 5.

Galvanized pipe and elbows may be utilized in the attic as well as above the roofline. The galvanized finish is desirable above the roofline due to its higher corrosion resistance.

Continue to add pipe sections through the flashing until the height of the vent cap meets the minimum height requirements specified in diagram 11 or local codes. Note that for steep roof pitches, the vertical height must be increased. A poor draft, or down drafting can result from high wind conditions near big trees or adjoining roof lines, in these cases, increasing the vent height may solve the problem.

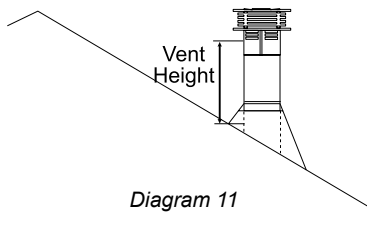

Diagram 11

Roof Pitch	Minimum Vent Height	
	Feet	Meters
flat to 7/12	2	0.61
over 7/12 to 8/12	2	0.61
over 8/12 to 9/12	2	0.61
over 9/12 to 10/12	2.5	0.76
over 10/12 to 11/12	3.25	0.99
over 11/12 to 12/12	4	1.22
over 12/12 to 14/12	5	1.52
over 14/12 to 16/12	6	1.83
over 16/12 to 18/12	7	2.13
over 18/12 to 20/12	7.5	2.29
over 20/12 to 21/12	8	2.44

- 7) Ensure vent is vertical and secure the base of the flashing to the roof with roofing nails, slide storm collar over the pipe section and seal with a mastic.
- 8) Install the vertical termination cap by twist locking it.

Notes:

- a) For multistorey vertical installations, a Ceiling Fire stop (Part # 963) is required at the second floor, and any subsequent floor. Diagram 12. The opening should be framed to 10 " x 10" inside dimensions, in the same manner as shown in diagram 9.
- b) Any occupied areas above the first floor, including closets and storage spaces, through which the vertical vent passes, must be enclosed.

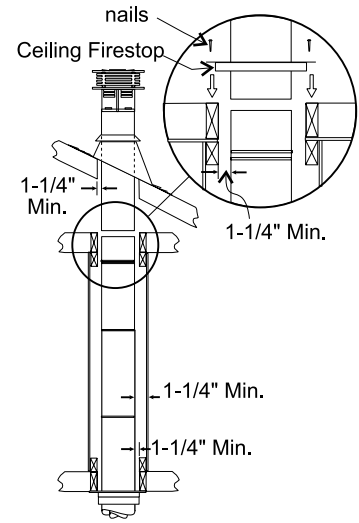
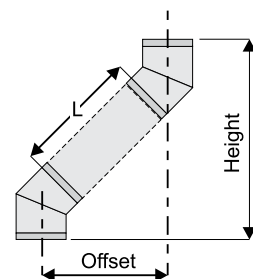

Diagram 12

Offset Chart

GS 6" (152mm) Nominal Diameter ID					
Offset		Pipe Length (L)		Height	
inches	mm	inches	mm	inches	mm
4 3/4	121	0	0	13 1/4	337
9	229	6	152	17 1/2	445
11 1/4	286	9	229	19 1/2	495
13 1/4	337	12	305	21 3/4	552
21 3/4	552	24	610	30 1/4	768
30 1/4	768	36	914	39	991
38	965	48	1219	47	1194



INSTALLATION

CONVERTING CLASS-A METAL CHIMNEY OR MASONRY CHIMNEY TO DIRECT VENT SYSTEM

There are two different types of direct vent conversion systems listed below. Follow the appropriate directions for your installation.

A) Through an existing factory built metal chimney going through the ceiling: A typical conversion of this type is shown in diagram 1. The concept of direct vent conversion is to connect an adaptor to an Underwriters Laboratories (UL) listed 4 inch diameter aluminum flex pipe which is then passed down through the center of the existing metal chimney system. Three sizes of Top Adaptors are available from Simpson Dura-Vent. The Retro Connector is attached to the bottom of the flex pipe. The Top Adaptor and the Retro Connector are attached to the existing chimney with sheet metal screws. The appliance is then connected to the chimney with appropriate black direct vent pipe and an adjustable length section.

B) Through the wall of an existing masonry chimney: A typical conversion of an existing masonry chimney is shown in Diagram 6. A Top Adaptor and Flashing are used at the top of the masonry chimney. The 4 inch aluminum liner is connected to the adaptor and is passed down the chimney and out through the masonry wall and attached to the Retro Connector. The Retro Connector is attached to the masonry wall and then connected to the direct vent pipe leading to the appliance.

Prior to installation and connection of the vent system to a factory-built or masonry chimney, the chimney must be inspected and thoroughly cleaned by a qualified service person, such as a certified chimney sweep or home inspection service.

The direct vent system must not be connected to a damaged factory-built or masonry chimney.

For factory built, zero clearance, and masonry chimneys cleanout doors and caps or plugs for cleanout tee fittings and ash dumps shall be secured in place and sealed before installing a Direct Vent system within the chimney.

If the appliance shuts off during operation, contact a qualified service person to determine if a negative pressure and/or leaky chimney condition exists. Do not operate the appliance until the problem is corrected.

Approved for US Installations Only
The use of an existing chimney as an air intake is not covered under the ANS Z21.88a-2007/ CSA 2.33a-2007 test methods and the resulting ITS/WHI product certification. The code Authority Having Jurisdiction must be consulted prior to proceeding with this installation method.

Converting a Factory Built Metal Chimney

- 1) Remove the existing chimney cap.
- 2) Measure the distance from the top end of the chimney to the bottom of the ceiling support box, add 3" (76mm) to this measurement, and cut a section of the 4" flex pipe to that length (the flex should already be extended to its nominal length).

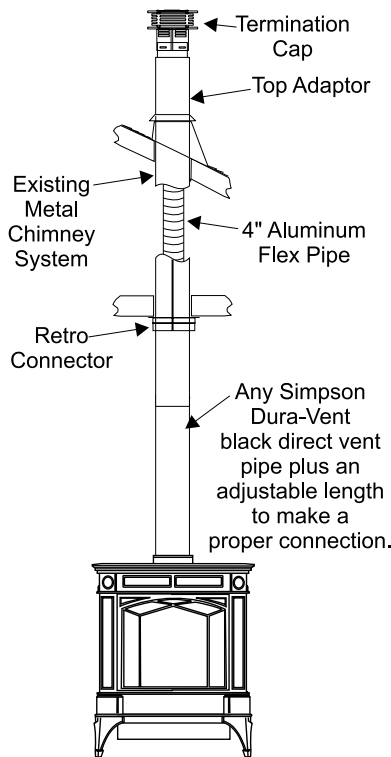

Diagram 1

- 3) Connect the end of the flex pipe section to the underside of the Top Adaptor using 3 sheet metal screws. Diagram 2.

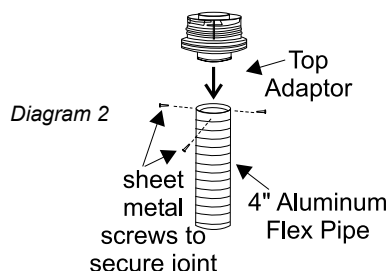

Diagram 2

- 4) Pass the flex pipe down through the center of the chimney system, and center the adaptor on the top of the chimney pipe. Drill four 1/8" diameter holes through the adaptor and into the chimney top. Insure that you are in fact, drilling into the metal on the chimney. Twist-lock the Termination Cap onto the Adaptor. (Diagram 3 and 4).

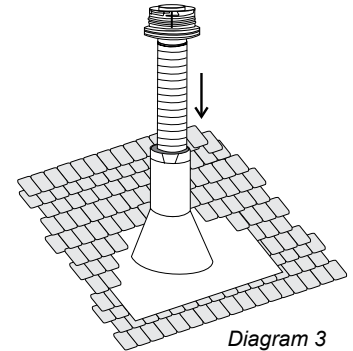

Diagram 3

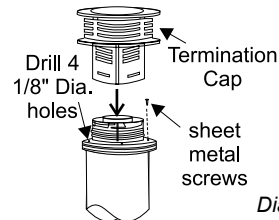

Diagram 4

- 5) Pull the flex pipe down through the ceiling support box, until it protrudes approximately 3" (76mm). Connect the flex pipe to the Retro Connector by slipping it into the 4-3/4" diameter sleeve on the top side of the Connector. Use 3 sheet metal screws to assemble these two parts.
- 6) Push the flex pipe back up into the ceiling support box, center the Retro Connector, and attach it to the support box, or decorative sleeve for double wall solid packed pipe, with the sheet metal screws (supplied). The holes in the Retro Connector are pre-punched. Diagram 5.

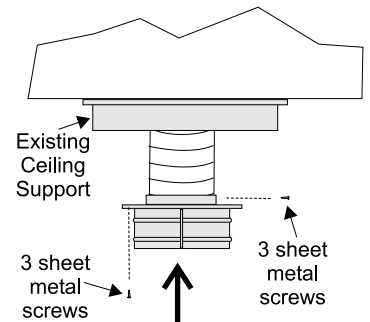

Diagram 5

- 7) The connection between the appliance and the Retro Connector may be completed with sections of black direct vent pipe, together with an adjustable length.

CATHEDRAL CEILINGS

Round Support (RDS) & Square Support (SQS)

If your home has a cathedral ceiling (no attic space between the ceiling and the roof), install the chimney and support as follows.

- 1) Situate the chimney in a convenient location as near as possible to the appliance outlet. Cut and frame a hole in the roof for the support. The sides of this hole must be vertical with 1/4" clearance.
- 2) Place the support in the opening. Lower it to the correct height as determined by the table and diagram below.

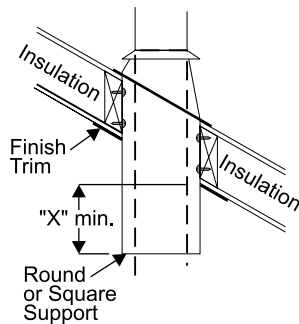

Slope	"X"
0/12 - 2/12	4"
2/12 - 7/12	5-1/2"
7/12 - 12/12	6-3/4"
12/12 - 24/12	7-1/2"
24/12+	12-1/2"

Using a level, make sure the support is vertical. If the support extends above the roof, cut it flush with the top of the roof. Nail the support to the frame opening using (8) 3" spiral nails or #8 x 1-1/2" screws.

Note: If you are using a 6" square support you may find it difficult to screw it in place because it is fairly small inside.

Simpson Dura-Vent has provided angle brackets with this support which can be screwed to the outside of the support box and nailed to surrounding framing as required. Use a minimum of four #8 x 1/2" screws per bracket. In some cases these brackets may need to be trimmed (e.g.: to fit under a flashing). Place the Finish Collar around the support and fasten it to the ceiling using the screws provided.

- 3) Use appropriate roof flashing. Place the flashing under the upper shingles and on top of the lower shingles approximately half of the flashing should be under the shingles.

- 4) Assemble the desired lengths of Black Pipe and Elbows necessary to reach from the appliance adapter up through the support box and flashing to proper height as per Dia. 12, local codes. Ensure that all pipe and elbow connections are in their fully twist lock position.
- 5) Ensure vent is vertical and secure flashing to the roof with roofing nails. Slide the storm collar over the pipe section and seal with a mastic.
- 6) Twist lock the vent cap on to the last section.

Support Extensions - Round (RDSE) or Square (SQSE)

Steep pitched cathedral ceilings may require the use of a support extension. This piece fits down inside the support and can be adjusted to increase the support's length by up to 22". The extension is attached to the support using the eight metal screws provided. Be sure there is at least a 2 inch overlap where the extension joins the support.

HIGH ELEVATION

This unit is approved in Canada for altitude to 4500 ft. (CAN/CGA-2.17-M91). For Natural Gas installations above 4500 ft. follow current CAN/CGA-B149.1.

GAS CONNECTION

The gas connection is a 3/8" NPT 90° elbow. The gas line can be rigid pipe or to make installation easier, use a listed flexible connector and/or copper tubing if allowed by local codes. Since some municipalities have additional local codes it is always best to consult with your local authorities and the CAN/CGA B149 installation codes.

For USA installations follow local codes and/or the current National Fuel Gas Code, ANSI Z223.1.

When using copper or flex connectors use only approved fittings. Always provide a union so that gas lines can be easily disconnected for burner and/or valve servicing. Flare nuts for copper lines and flex connectors are usually considered to meet this requirement.

IMPORTANT: ALWAYS CHECK FOR GAS LEAKS WITH A SOAP AND WATER SOLUTION OR GAS LEAK DETECTOR. DO NOT USE OPEN FLAME FOR LEAK TESTING.

Note: Prior to any pressure testing of the gas supply piping system that exceeds test pressures of 1/2 psig, this appliance must be disconnected from the piping system. If test pressures equal to or less than 1/2 psig are used then this appliance must be isolated from the piping system by closing its individual manual shut-off valve during the testing.

H15-NG1 System Data	
For 0 to 4500 feet altitude	
Burner Inlet Orifice Sizes:	#47
Max. Input Rating	18,000 Btu/h
Min. Input Rating	10,500 Btu/h
Supply Pressure	min.5.0" w.c.
Manifold Pressure (High)	3.8"+/- 0.2"w.c.

H15-LP1 System Data	
Conversion Kit# 380-969	
For 0 to 2000 feet altitude	
Burner Inlet Orifice Sizes:	#55
Max. Input Rating	18,000 Btu/h
Min. Input Rating	10,600 Btu/h
For 2000 to 4500 feet altitude	
Burner Inlet Orifice Sizes:	#56
Max. Input Rating	15,500 Btu/h
Min. Input Rating	8,200 Btu/h
Supply Pressure	min.12.0" w.c.
Manifold Pressure (High)	11"+/- 0.2" w.c.

INSTALLATION

AERATION ADJUSTMENT

The air shutter can be adjusted by moving the adjusting wire up or down. The wire is accessed through the bottom. Open the air shutter for a blue flame or close for a yellow flame. The burner aeration is factory set but may need adjusting due to either the local gas supply or altitude.

Minimum Air Shutter Opening:

3/16"	Natural Gas
1/4"	Propane

CAUTION: Carbon will be produced if air shutter is closed too much.

Note: Any damage due to carboning resulting from improperly setting the aeration controls is NOT covered under warranty.

Note: Aeration Adjustment should only be performed by an authorized FPI installer at the time of installation or service.



Pull adjustment wire up or down to close aeration.

Closed - Tall yellow
Open - Short Blue

GAS PIPE PRESSURE TESTING

The appliance must be isolated from the gas supply piping system by closing its individual manual shut-off valve during any pressure testing of the gas supply piping system at test pressures equal to or less than 1/2 psig. (3.45 kPa). Disconnect piping from valve at pressures over 1/2 psig.

The manifold pressure is controlled by a regulator built into the gas control, and should be checked at the pressure test point.

Note: To properly check gas pressure, both inlet and manifold pressures should be checked using the valve pressure ports on the valve.

- 1) Make sure the valve is in the "OFF" position.
- 2) Loosen the "IN" and/or "OUT" pressure tap(s), turning counterclockwise with a 1/8" wide flat screwdriver.
- 3) Attach manometer to "IN" and/or "OUT" pressure tap(s) using a 5/16" ID hose.
- 4) Light the pilot and turn the valve to "ON" position. Read manometer.
- 5) The pressure check should be carried out with the unit burning and the setting should be within the limits specified on the safety label.
- 6) When finished reading manometer, turn off the gas valve, disconnect the hose and tighten the screw (clockwise) with a 1/8" flat screwdriver.
Note: Screw should be snug, but do not over tighten

Valve Description

- 1) Gas on/off knob
- 2) Manual high/low adjustment
- 3) Pilot Adjustment
- 4) Thermocouple Connection
- 5) Main Operator
- 6) Outlet Pressure Tap (Manifold Pressure)
- 7) Inlet Pressure Tap (Supply Pressure)
- 8) Pilot Outlet
- 9) Main Gas Outlet
- 10) Flange Securing Screw Holes
- 11) Alternative TC Connection Point
- 12) Thermoelectric Unit
- 13) Additional Valve Mounting Hole

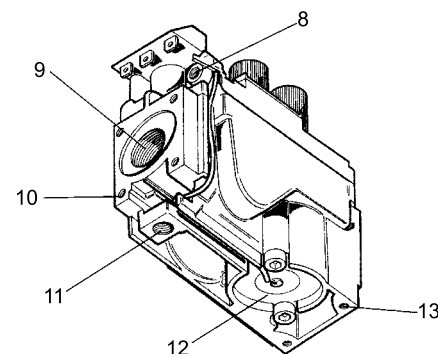
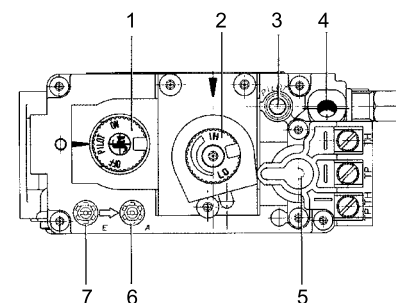

CONVERSION KIT# 381-969 FROM NG TO LP

THIS CONVERSION MUST BE DONE BY A QUALIFIED GAS FITTER IF IN DOUBT DO NOT DO THIS CONVERSION !!

Each Kit contains one LPG Conversion Kit and one DC Sparker Kit.

LPG Conversion Kit Contains:

Qty.	Part #	Description
1	904-575	Burner Orifice #55
1	918-590	Label "Converted to Propane"
1	908-528	Red "LPG" label
1	904-529	5/32" Allen Key
1	910-037	LP Injector (Pilot Orifice)
1	918-479	Instruction Sheet

DC Sparker Kit Contains:

Qty.	Part #	Description
1	820-475	Bracket DC Sparker
1	820-476	Bracket DC Sparker
1	904-153	Washer #8 External Star
1	904-330	Nut 8-32 Hex
1	904-438	Plug Nylon 0.750 Hole, Black
1	904-531	Bushing Split Plastic 0.500 in.
1	904-543	Screw 8-32 x 3/4 Pan Head
2	904-553	Screw #8 x 1/2 Type "B", Black Oxide
1	910-073	Spark Generator Battery Holder
1	910-074	Spark Generator Switch C/W Wire
1	910-078	Battery Size AA Energizer En91
2	910-199	Clip Wire Holder
1	910-903	Wire Fan To Power Cord Ground 30 in.
	904-781	Velcro Hook, Black
	904-782	Velcro Hook, Black

Installation of LPG Conversion Kit:

- 1) Shut off the gas supply.
- 2) Lift off Cast Top, remove Cast Front and Glass Door (refer to the glass replacement section in the manual) and carefully remove logs and lava rock.

- 3) Remove burner by removing the 2 screws on each side and then slide the burner to the left and lift out.

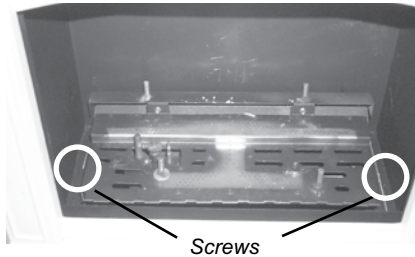

Note: Use a magnetic type screwdriver if possible.

Pilot assembly is now accessible for steps the following steps.



- 4) Turn control knob to the "OFF" position.
- 5) Remove the black protection cap by hand from the high-low knob (Fig.1).

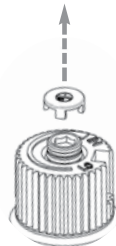

Fig.1

- 6) Insert a 5/32" or 4mm Allen wrench into the hexagonal key-way of the screw (Fig. 2), rotate it counter-clockwise until it is free and extract it.

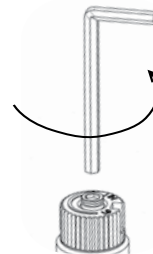

Fig.2

- 7) Check that the screw is clean and if necessary remove dirt.
- 8) Flip the screw (Fig. 3).

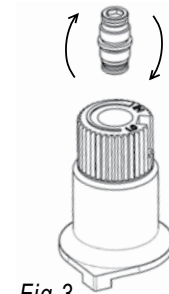

Fig.3

- 9) Using the Allen wrench as shown in Fig.4, rotate the screw clockwise until snug, do not overtighten.

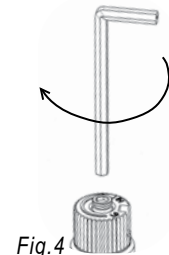

Fig.4

WARNING!
Do not overtighten the screw.
Recommended to grip the wrench by the short side.

- 10) Verify that if the conversion is from NG to LPG, the screw must be reassembled with the red o-ring visible (Fig. 5).

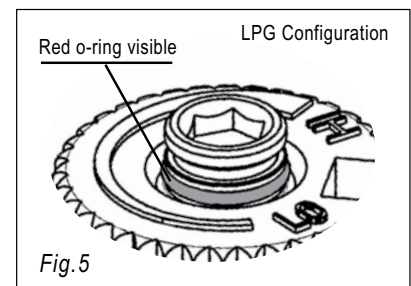

Fig.5

INSTALLATION

- 11) Reassemble the black protection cap (Fig. 6).

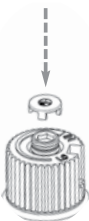
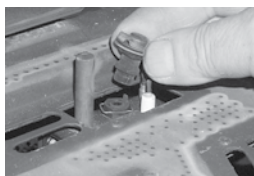

Fig. 6

WARNING!
Also check that the pilot and main burner injectors are appropriate for the gas type.

- 12) Pull off the pilot cap to expose the pilot orifice.



- 13) Unscrew the pilot orifice with the allen key and replace with the LP pilot orifice in the kit.

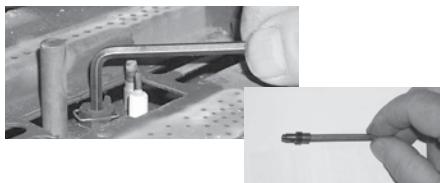

- 14) Remove burner orifice with a 1/2" wrench and discard. Use another wrench to hold on to the elbow behind the orifice.

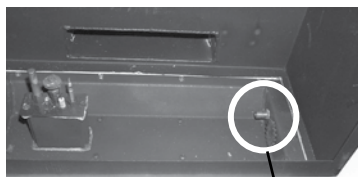

Burner Orifice

- 15) Reinstall new burner orifice LP stamped #55 and tighten.

- 16) Reverse steps 3) to 2).
17) Attach the label "This unit has been converted to LPG" near or on top of the serial # decal.
18) Replace yellow "Natural Gas" label with red "LPG" label.

Installation of the DC Sparker:

- 19) Remove the control panel by unscrewing the 2 screws.



- 20) First, remove the Piezo Ignition Wire from the Piezo Ignitor. Then remove the Piezo Ignitor from the control panel.

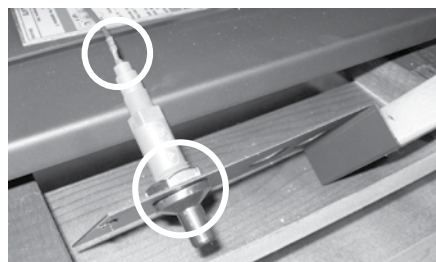

- 21) Plug up the Piezo hole with the plastic bushing.



- 22) Attach the DC sparker generator connector to the valve with a screw.

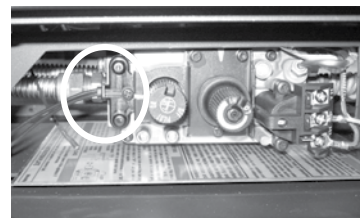
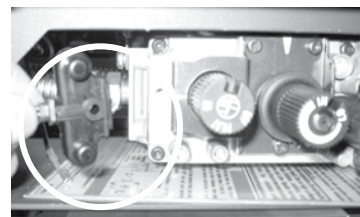

- 23) Remove the stove's rear panel by unscrewing the two screws.



- 24) Attach the ground wire to the grounding stud.

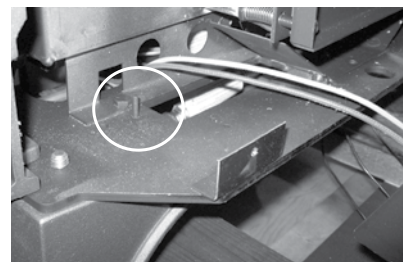

Before

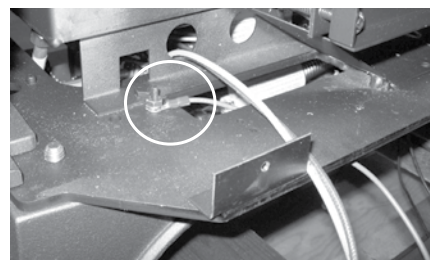

After

- 25) Attach the Piezo ignition wire to the DC Sparker.

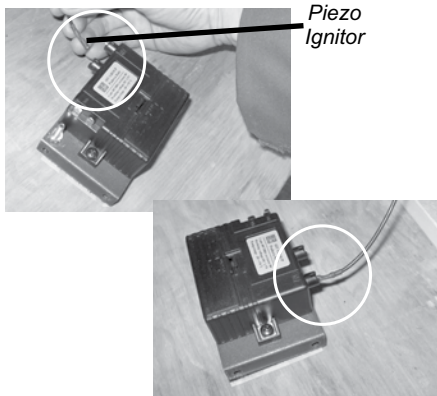

- 26) Insert both the ground wire and the DC sparker generator wire through the hole of the DC spark heat shield.

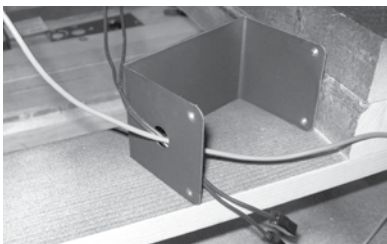

- 27) Install the plastic bushing over the outside of the hole.

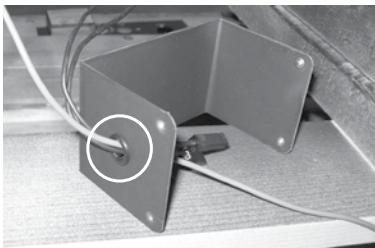

- 28) Attach the ground wire to the DC spark mounting bracket.



- 29) Attach the DC sparker generator wires to the DC sparker.

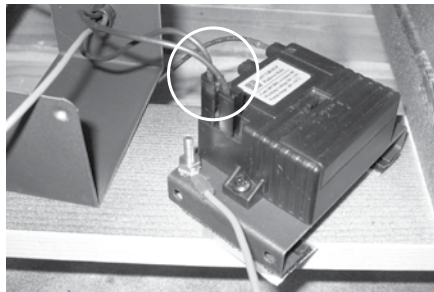

- 30) Install the supplied battery into the DC Sparker Box by opening the battery compartment.

NOTE: The battery in the DC Sparker Box will need to be replaced annually.

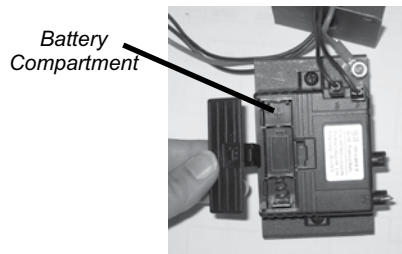

- 31) Attach the heat shield to the DC sparker, then mount onto the stove using the velcro already attached to the DC Sparker mounting bracket.

Note: We recommend attaching the DC sparker box to the bottom rear of the stove (or place this in a convenient location, away from the heat source).

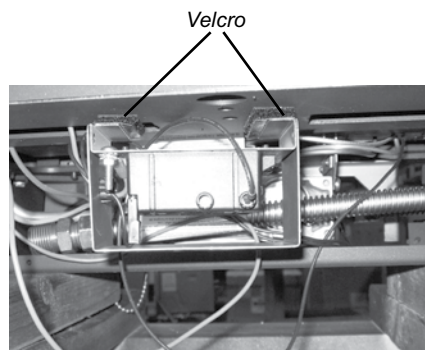

- 32) Tie up the loose wire with the wire clip.

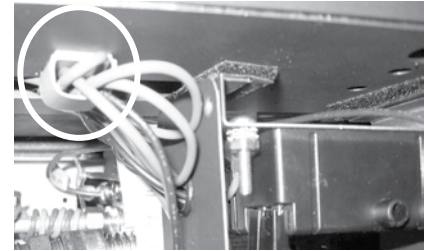

LOG SET INSTALLATION

Read the instructions below carefully and refer to the diagrams. If the logs are broken do not use the unit until they are replaced. Broken logs can interfere with the pilot operation.

The log kit contains the following:

- a) Rear Log
- b) Left Side Front Log
- c) Right Side Front Log
- d) Center Front Log
- e) Embers
- f) Platinum Embers 946-669 (supplied with packaged manual)

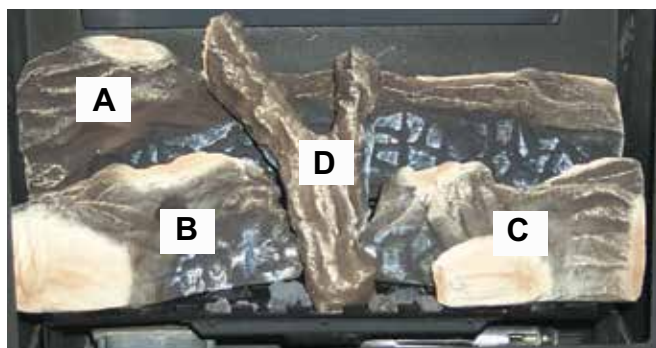

- 1) Shut off the gas supply.
- 2) Lift off Cast Top.
- 3) Remove Cast Front by removing the 2 screws using a 7/16" wrench. Pull front out and then up as shown below.

Inside view



- 5) Carefully remove the logs from the unit and unwrap them. The logs are fragile, handle with care - do not force into position.
- 6) Place the rear log on the 2 rear log locating pins on the rear of the burner with the flat side to the back.

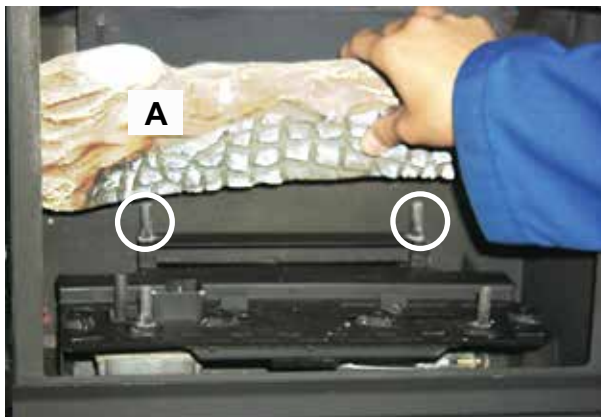

- 7) Place the 2 front logs on the front log locating pins. Ensure the back of both logs rest against the tabs.



Left Front Log



- 8) Take the embers and place on the burner in the space between the 2 front logs, ensure not to cover any burner ports. Do not put embers on the burner in the area between the front logs and the rear log. See photo below.

Separate platinum embers and place at the front of the burner in and around where the embers are placed. Avoid stacking platinum embers.

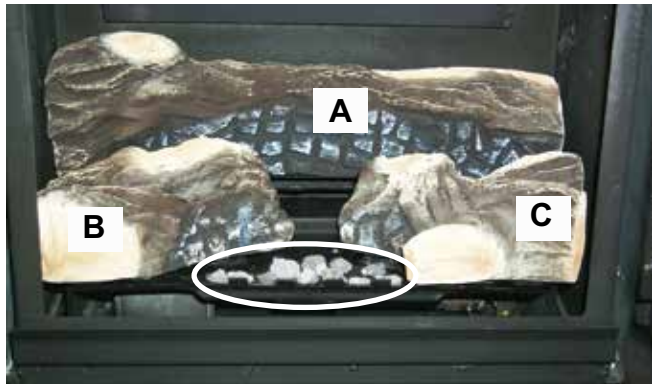

- 9) Place the center cross log on the top of the rear log and position as shown below.

Logs must be oriented as shown below.

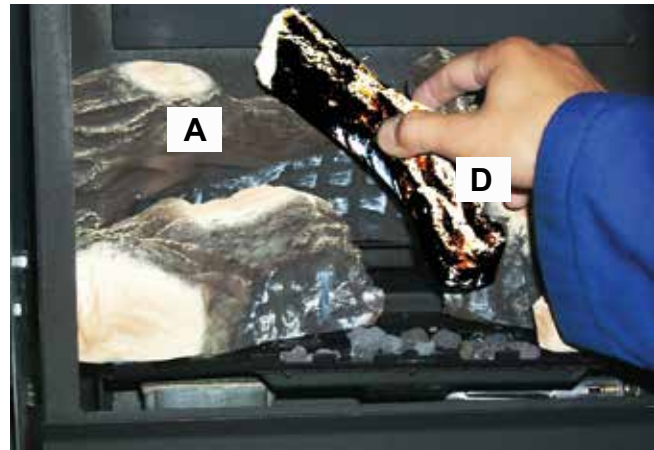

- 10) Test fire to ensure proper light off (make sure flame flows smoothly from one end of burner to the other). If there is any flame hesitation, check that area for any blockage of the burner ports.

- 11) Re-install the Glass Front, Cast Front and Top.

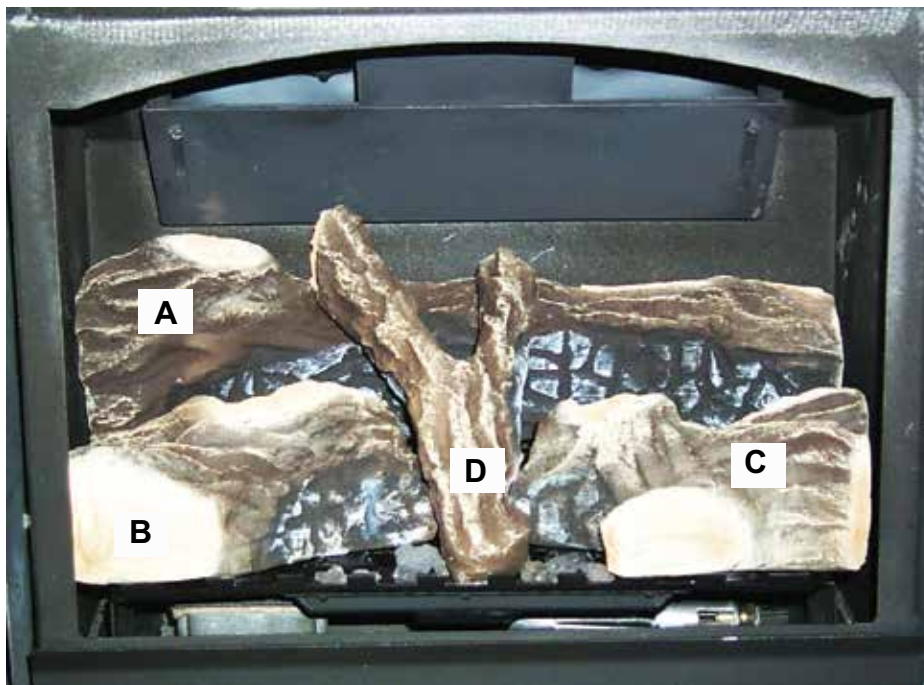

INSTALLATION

OPTIONAL WALL THERMOSTAT

A wall thermostat may be installed if desired. Connect the wires as per the wiring diagrams. Note that the wires are connected to the "TH" on the gas valve. Use table below to determine the maximum wire length:

Note: Preferable if the thermostat is installed on an interior wall.

Hampton® offers an optional programmable thermostat but any 250-750 millivolt rated non-anticipator type thermostat that is CSA, ULC or UL approved may be used.

CAUTION
Do not wire millivolt wall thermostat wires to 120V wire.

Thermostat Wire Table

Recommended Maximum Lead Length (Two-Wire) When Using Wall Thermostat (CP-2 System)	
Wire Size	Max. Length
14 GA.	50 Ft.
16 GA.	32 Ft.
18 GA.	20 Ft.
20 GA.	12 Ft.
22 GA.	9 Ft.

OPTIONAL REMOTE CONTROL

Use the Hampton® Remote Control Kit approved for this unit. Use of other systems may void your warranty.

The remote control kit comes with a hand held transmitter, a receiver and a wall mounting plate.

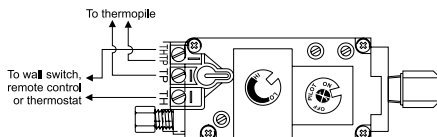

- 1) Choose a convenient location on the wall to install the receiver and the receptacle box (protection from extreme heat is very important). Run wires from the fireplace to that location, use Thermostat Wire Table.
- 2) Connect the wires as per the wiring diagram below.

CAUTION
Do not wire millivolt remote control wires to 120V wire.

- 3) Install 3AAA alkaline batteries in transmitter and 4 AA alkaline batteries in the receiver. Install the receiver and its cover in the wall. Switch the remote receiver to "remote" mode. The remote control is now ready for operation.

FINAL CHECK

Before leaving this unit with the customer, the installer must ensure that the appliance is firing correctly. This includes:

- 1) Clocking the appliance to ensure the correct firing rate (rate noted on label) at 15 minutes.
- 2) If required, adjusting the primary air to ensure that the flame does not carbon. First allow the unit to burn for 15 min. to stabilize.
- 3) Check for proper draft.

CAUTION

Any alteration to the product that causes soot-ing or carboning that results in damage to the exterior facia is not the responsibility of the manufacturer.

WIRING DIAGRAMS

If any of the original wires as supplied with the appliance must be replaced, it must be replaced with CSA type SEW (200°C) or its equivalent.

This heater does not require a 120V A.C. supply for operation. In case of a power failure, the burner switch and the optional remote control/thermostat will continue to operate. However, a 120V A.C. power supply is needed for the fan/blower operation.

Caution: Ensure that the wires do not touch any hot surfaces and are away from sharp edges.

CAUTION: Label all wires prior to disconnection when servicing controls. Wiring errors can cause improper and dangerous operation.

For NATURAL GAS Units and Units NOT Equipped with DC Spark Boxes

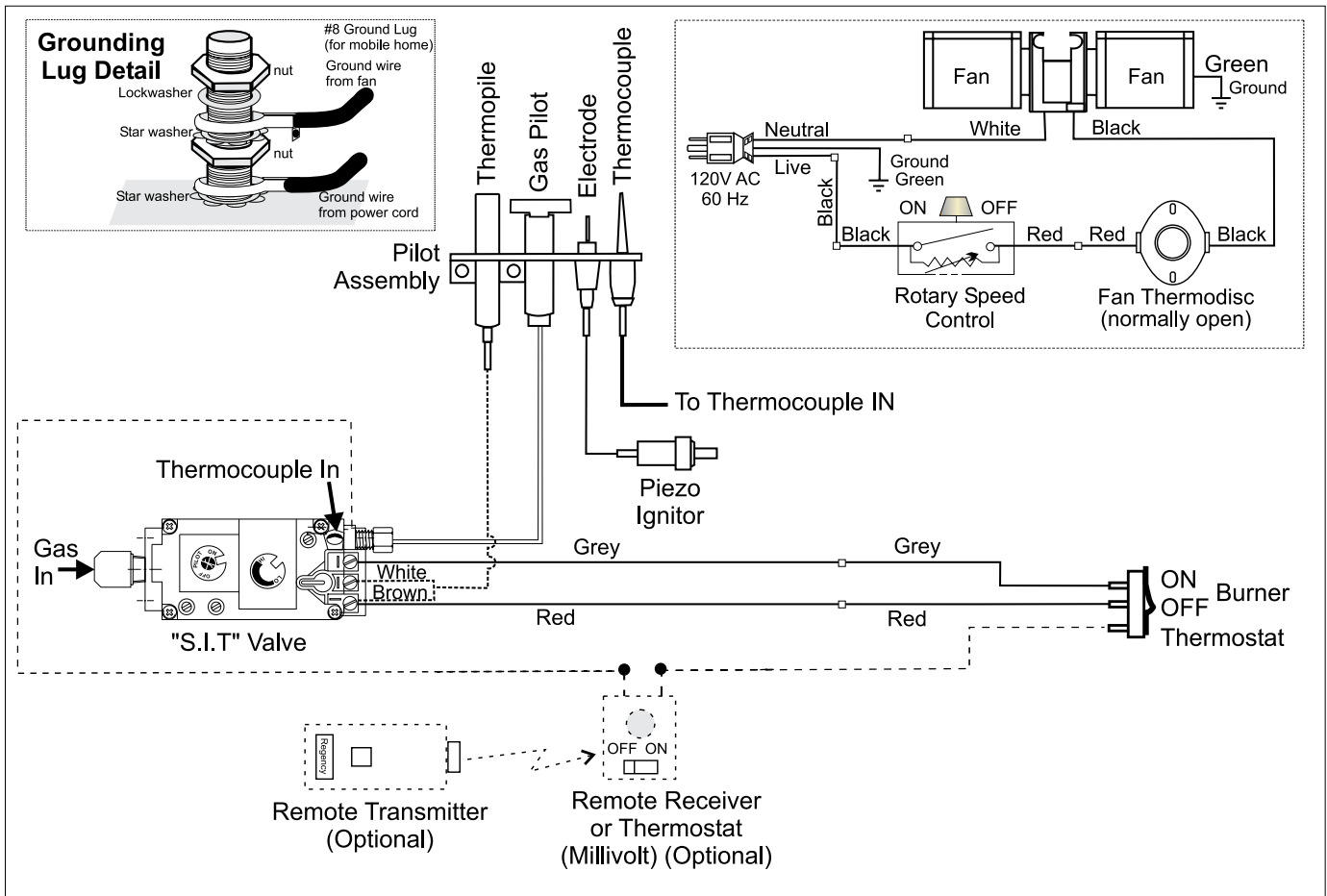

WARNING: Electrical Grounding Instructions

This appliance is equipped with a three pronged (grounding) plug for your protection against shock hazard and should be plugged directly into a properly grounded three-prong receptacle. Do not cut or remove the grounding prong from this plug.

INSTALLATION

For PROPANE Units and Units Equipped with DC Spark Boxes*

*For installation of the DC Spark Box refer to the LP Conversion instructions in this manual.

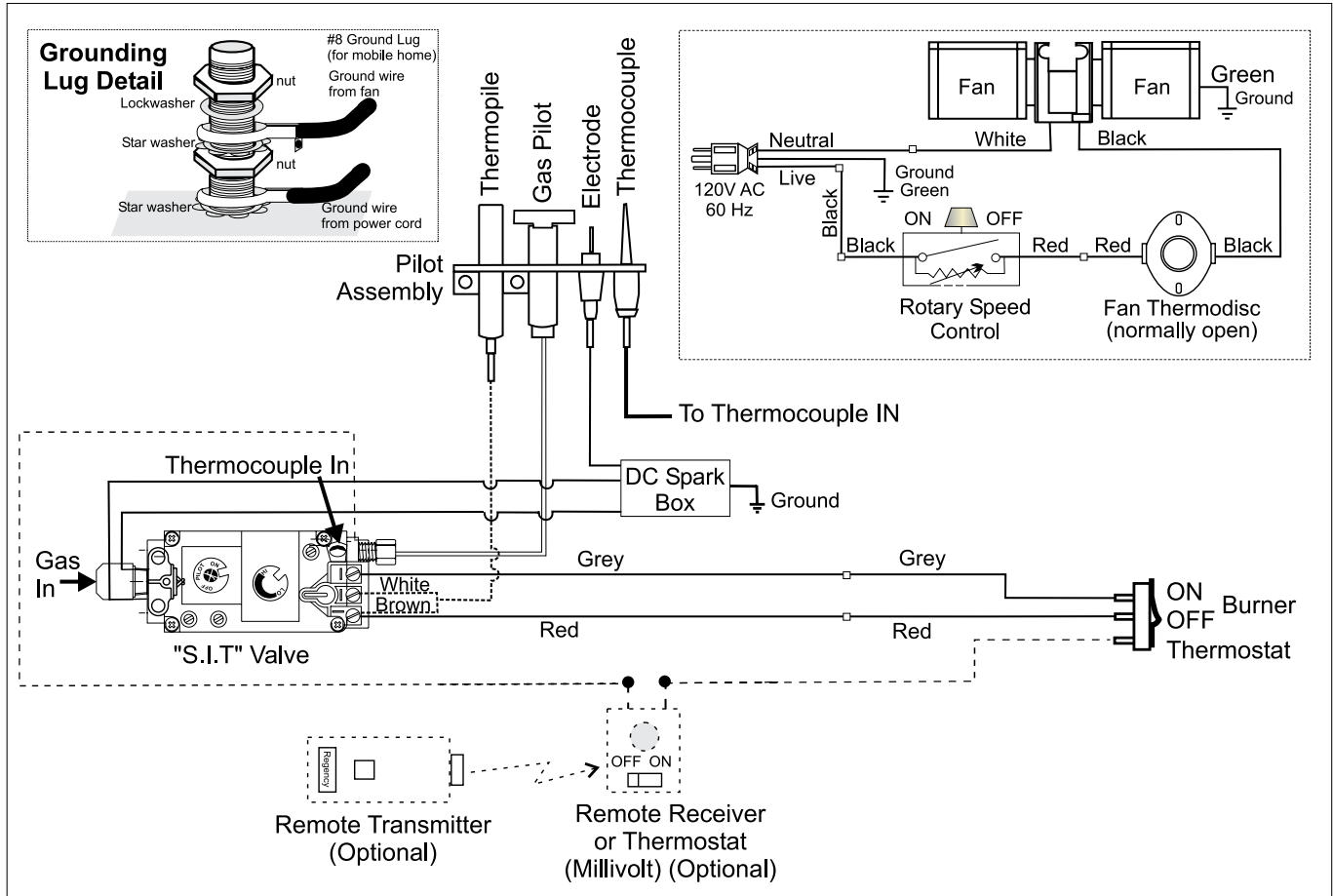

OPERATING INSTRUCTIONS

- 1) Read and understand these instructions before operating this appliance.
- 2) Check to see that all wiring is correct and enclosed to prevent possible shock.
- 3) Check to ensure there are no gas leaks.
- 4) Make sure the glass in the door frame is properly positioned. Never operate the appliance with the glass removed. Never strike the glass.
- 5) Verify that the venting and cap are unobstructed.
- 6) Verify log placement. If the pilot cannot be seen when lighting the unit - the logs have been incorrectly positioned.
- 7) The unit should never be turned off, and on again without a minimum of a 60 second wait.

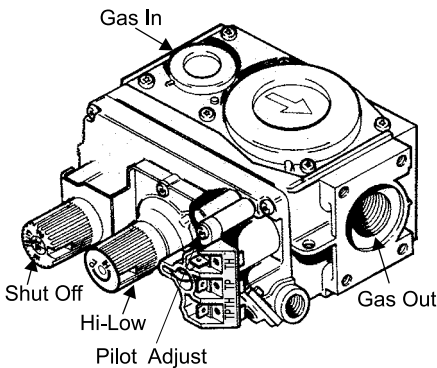

LIGHTING PROCEDURE

IMPORTANT

To ignite or reignite the pilot, the door to the firebox must be opened.

NOTE: For all propane units and units equipped with electric spark boxes, see "Copy of Lighting Plate Instructions" section for more details.

Only when the pilot holds, without pressure being applied to the control knob, should the door to the firebox be closed. The unit **must never** be operated with the glass or door open.

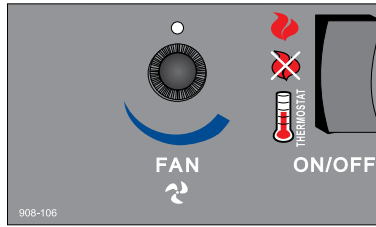

IM -

IMPORTANT: Gas on/off knob cannot be turned from "PILOT" to "OFF" unless it is partially depressed.

- 1) Turn stove OFF using the Burner "ON/OFF" switch remote or thermostat. Switches are located at the top right hand corner (rear) of the stove.
- 2) Turn gas control knob so indicator points to "OFF" position and allow 5 minutes for any gas in the combustion chamber to escape.
- 3) Turn gas control knob counterclockwise so indicator points to the "PILOT" position. Depress the gas control knob fully. Depress the igniter button several times until the pilot lights. After approximately one minute, release the gas control knob. The pilot flame should continue to burn. If the pilot does not remain lit, repeat operation allowing a longer period before releasing gas control knob.
- 4) When the pilot stays lit, turn the gas knob further counterclockwise to the "ON" position.
- 5) Use the thermostat or remote control to turn on the unit.
- 6) Rotate the flame height regulator to adjust the flame height higher or lower.

SHUTDOWN PROCEDURE

- 1) Use the thermostat or remote control to turn off the main burner.
- 2) Turn the main gas control clockwise to the "OFF" position to turn off the pilot (push knob in slightly).
- 3) Turn off all electric power to appliance if service is to be performed.

FIRST FIRE

The **FIRST FIRE** in your stove is part of the paint curing process. To ensure that the paint is properly cured, it is recommended that you burn your fireplace for at least four (4) hours the first time you use it with the fan on. When first operated, the unit will release an odour caused by the curing of

the paint and the burning off of any oils remaining from manufacturing. Smoke detectors in the house may go off at this time. Open a few windows to ventilate the room for a couple of hours. The glass may require cleaning.

DO NOT ATTEMPT TO CLEAN THE GLASS WHILE IT IS STILL HOT!

Note: When the glass is cold and the appliance is lit, it may cause condensation and fog the glass. This condensation is normal and will disappear in a few minutes as the glass heats up.

DO NOT BURN THE APPLIANCE WITHOUT THE GLASS FRONT IN PLACE.

During the first few fires, a white film may develop on the glass front as part of the curing process. The glass should be cleaned or the film will bake on and become very difficult to remove. Use a non-abrasive cleaner and NEVER clean the glass while it is hot.

ADJUSTING FLAME HEIGHT

Your heater has an adjustable flame to tailor the look and heat output to your specific needs. It is adjusted by turning the flame adjustment dial on the gas control valve.

Turn clockwise to adjust the flame higher, counterclockwise for a lower flame.

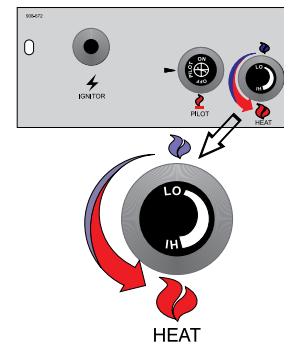

AUTOMATIC CONVECTION FAN OPERATION

The fan operates automatically - turn the knob at the top right rear corner to adjust to the desired speed. The fan will turn on as the stove comes up to operating temperature. After the unit has been turned off and the unit cooled to below a useful heat output range the fan will shut off automatically.

COPY OF THE LIGHTING PLATE INSTRUCTIONS

FOR YOUR SAFETY READ BEFORE LIGHTING

This appliance must be installed in accordance with local codes, if any; if none, follow the National Fuel Gas Code, ANSI Z223.1/ NFPA 54, or Natural Gas and Propane Installation Codes, CSA B149.1. (Australia: A S5601-2004, New Zealand: NZS 5261)

WARNING: If you do not follow these instructions exactly, a fire or explosion may result causing property damage, personal injury or loss of life. Improper installation, adjustment, alteration, service or maintenance can cause injury or property damage. Refer to the owner's information manual provided with this appliance. For assistance or additional information consult a qualified installer, service agency or gas supplier.

- A) This appliance has a pilot which must be lighted by hand, following the instructions below exactly.
- B) **BE FORE LIGHTING** smell all around the appliance area for gas. Be sure to smell next to the floor because some gas is heavier than air and will settle on the floor.
 - WHAT TO DO IF YOU SMELL GAS
 - Do not try to light any appliance
 - Do not touch any electric switch, do not use any phone in your building
 - Immediately call your gas supplier from a neighbors phone. Follow the gas supplier's instructions.
 - If you cannot reach your gas supplier, call the fire department.
- C) Use only your hand to push in or turn the gas control knob. Never use tools. If the knob will not push in or turn by hand, don't try to repair it, call a qualified service technician. Force or attempted repair may result in a fire or explosion.
- D) Do not use this appliance if any part has been under water. Immediately call a qualified service technician to inspect the appliance and to replace any part of the control system and any gas control which has been under water.
- E) This appliance needs fresh air for safe operation and must be installed so there are provisions adequate combustion + ventilation air.

CAUTION: Hot while in operation. Do not touch. Severe Burns may result. Due to high surface temperatures keep children, clothing and furniture, gasoline and other liquids having flammable vapors away. Keep burner and control compartment clean. See installation and operating instructions accompanying appliance.

LIGHTING INSTRUCTIONS

STOP! Read the safety information above on this label.

FOR UNITS NOT EQUIPPED WITH ELECTRIC SPARK:

- 1) Push in gas control knob slightly and turn clockwise  to "OFF". Knob cannot be turned from "PILOT" to "OFF" unless knob is pushed in slightly. Do not force.

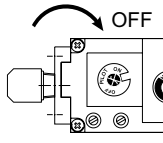
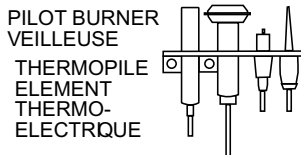

- 2) Wait five (5) minutes to clear out any gas. If you then smell gas STOP! follow "B" in the safety information above on this label. If you don't smell gas, go to the next step.

- 3) Turn knob on gas control counterclockwise  to "PILOT".
- 4) Push in control knob all the way and hold in. Immediately push black button on spark igniter until pilot lights. Continue to hold the control knob in for about 1/2 minute after the pilot is lit. Release knob and it will pop back up. Pilot should remain lit. If it goes out, repeat steps 3) and 4).
If knob does not pop up when released, stop and immediately call your service technician or gas supplier.
If the pilot will not stay lit after several tries, turn the gas control knob to "OFF" and call your service technician or gas supplier.

- 5) Turn gas control knob counterclockwise  to "ON".

- 6) Use rocker switch to operate main burner.

FOR ALL PROPANE UNITS AND UNITS EQUIPPED WITH ELECTRIC SPARK BOXES:

- 1) Push in gas control knob slightly and turn to "PILOT" position.
- 2) Push in control knob all the way and hold in until the pilot lights up. Continue to hold the control knob in for about 20 seconds after the pilot is lit. Release knob.
- 3) Push in gas control knob slightly and turn to "ON" position.
- 4) Turn ON the flame switch.

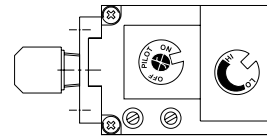

TO TURN OFF GAS APPLIANCE

- 1) Turn off the flame switch.
- 2) Push in the gas control knob slightly and turn clockwise  to "OFF". Do not force.
- 3) Turn off all electric power to the appliance if service is to be performed.

You may shut off the pilot during prolonged non use periods to conserve fuel.

DO NOT REMOVE THIS INSTRUCTION PLATE

918-474b

NORMAL OPERATING SOUNDS OF GAS APPLIANCES

It is possible that you will hear some sounds from your gas appliance. This is perfectly normal due to the fact that there are various gauges and types of steel used within your appliance. Listed below are some examples. All are **normal operating sounds** and should not be considered as defects in your appliance.

Blower:

Hampton® gas appliances use high tech blowers to push heated air farther into the room. It is not unusual for the fan to make a "whirring" sound when ON. This sound will increase or decrease in volume depending on the speed setting of your fan speed control.

Burner Tray:

The burner tray is positioned directly under the burner tube(s) and logs and is made of a different gauge material from the rest of the firebox and body. Therefore, the varying thicknesses of steel will expand and contract at slightly different rates which can cause "ticking" and "cracking" sounds. You should also be aware that as there are temperature changes within the unit these sounds will likely re-occur. Again, this is normal for steel fireboxes.

Blower Thermodisc:

When this thermally activated switch turns ON it will create a small "clicking" sound. This is the switch contacts closing and is normal.

Pilot Flame:

While the pilot flame is on it can make a very slight "whisper" sound.

Gas Control Valve:

As the gas control valve turns ON and OFF, a dull clicking sound may be audible, this is normal operation of a gas regulator or valve.

Unit Body/Firebox:

Different types and thicknesses of steel will expand and contract at different rates resulting in some "cracking" and "ticking" sounds will be heard throughout the cycling process.

2) Clean glass (never when unit is hot), appliance, and door with a damp cloth. Never use an abrasive cleaner.

3) The heater is finished in a porcelain finish or with a heat resistant paint and should only be refinished with heat resistant paint (not with wall paint).

Never use an abrasive cleaner on the porcelain finish as it may scratch the surface.

4) Make a periodic check of burner for proper position and condition. Visually check the flame of the burner periodically, making sure the flames are steady; not lifting or floating. If there is a problem, call a qualified service person.

5) **Caution: Label all wires prior to disconnection when servicing controls. Wiring errors can cause improper and dangerous operation.**

6) The appliance and venting system must be inspected before use, and at least annually, by a qualified field service person, to ensure that the flow of combustion and ventilation air is not obstructed.

During the annual service call, the burner should be removed from the burner tray and cleaned. Replace the embers but do not block the pilot.

7) Keep the area near the appliance clear and free from combustible materials, gasoline, and other flammable vapours and liquids.

CLOTHING OR OTHER FLAMMABLE MATERIAL SHOULD NOT BE PLACED ON OR NEAR THE APPLIANCE.

8) Each time the appliance is lit, it may cause condensation and fog the glass. This condensation and fog is normal and will disappear in a few minutes as the glass heats up.

Never operate the appliance without the glass properly secured in place.

9) Periodically check the pilot flames. Correct flame pattern has three strong blue flames: 1 flowing around the thermopile and 1 around the thermocouple, and 1 flowing across the rear of the burner (it does not have to be touching the burner).

Note: If you have an incorrect flame pattern, contact your Hampton® dealer for further instructions.

PILOT ADJUSTMENT

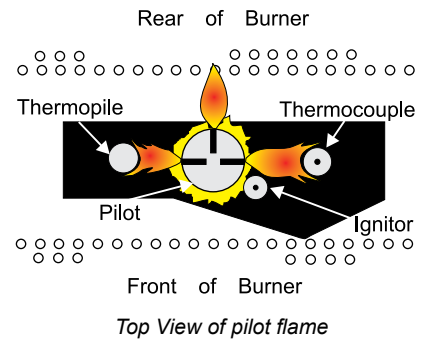

Incorrect flame pattern will have small, probably yellow flames, not coming into proper contact with the rear of the burner or thermopile.

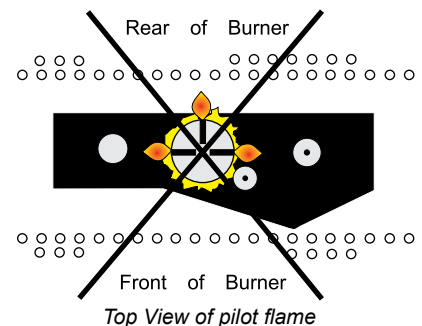

WARNING: CHILDREN AND ADULTS SHOULD BE ALERTED TO THE HAZARDS OF HIGH SURFACE TEMPERATURE AND SHOULD STAY AWAY TO AVOID BURNS OR CLOTHING IGNITION. YOUNG CHILDREN SHOULD BE CAREFULLY SUPERVISED WHEN THEY ARE IN THE SAME ROOM AS THE APPLIANCE.

DO NOT USE THIS APPLIANCE IF ANY PART HAS BEEN UNDER WATER. IMMEDIATELY CALL A QUALIFIED SERVICE TECHNICIAN TO INSPECT THE APPLIANCE AND TO REPLACE ANY PART OF CONTROL SYSTEM AND ANY GAS CONTROL WHICH HAS BEEN UNDER WATER

CAUTION: ANY SAFETY SCREEN OR GUARD REMOVED FOR SERVICING AN APPLIANCE MUST BE REPLACED PRIOR TO OPERATING THE APPLIANCE.

MAINTENANCE INSTRUCTIONS

1) Always turn off the valve before cleaning. For relighting, refer to lighting instructions. Keep the burner and control compartment clean by brushing and vacuuming at least once a year. When cleaning the logs, use a soft clean paint brush as the logs are fragile and easily damaged.

GENERAL VENT MAINTENANCE

Conduct an inspection of the venting system semi-annually. Recommended areas to inspect as follows:

- 1) Check the Venting System for corrosion in areas that are exposed to the elements. These will appear as rust spots or streaks, and in extreme cases, holes. These components should be replaced immediately.
- 2) Remove the Cap, and shine a flashlight down the Vent. Remove any bird nests, or other foreign material.
- 3) Check for evidences of excessive condensation, such as water droplets forming in the inner liner, and subsequently dripping out the joints. Continuous condensation can cause corrosion of caps, pipe, and fittings. It may be caused by having excessive lateral runs, too many elbows, and exterior portions of the system being exposed to cold weather.
- 4) Inspect joints, to verify that no pipe sections or fittings have been disturbed, and consequently loosened. Also check mechanical supports such as Wall Straps, or plumbers' tape for rigidity.

LOG REPLACEMENT

The unit should never be used with broken logs. Turn off the gas valve and allow the unit to cool before opening door to carefully remove the logs. The pilot light generates enough heat to burn someone. If for any reason a log should need replacement, you must use the proper replacement log. The position of these logs must be as shown in the diagram under Log Installation.

Note: Improper positioning of logs may create carbon build-up and will alter the unit's performance which is not covered under warranty.

GLASS REPLACEMENT

Your stove is supplied with high temperature, 5 mm Neoceram ceramic glass that will withstand the highest heat that your unit will produce. In the event that you break your glass by impact, purchase your replacement door from an authorized Hampton® dealer only, and follow our step-by-step instructions for replacement.

- 1) Lift off Cast Top.



- 2) Open the 2 latches to remove Glass Front. Angle out and then lift, same as Cast Front.
- 3) Remove glass and replace with new glass.



Latches

- 4) Re-install Cast Top.

WARNING: Do not operate appliance with glass panel removed, cracked or broken. Replacement of the glass should be done by a licensed or qualified service person.

Note: Wearing gloves will protect your hands while handling glass.

FAN MAINTENANCE

If your fan requires maintenance or replacement, access to the fan is through the rear access panel on the back of the unit.

IMPORTANT: These fans collect a lot of dust from within your home. Ensure you maintain these fan motors on a regular basis by vacuuming out the fan squirrel cages, around the motor, and around the grills on the back of the stove.

WARNING:
Electrical Grounding Instructions
 This appliance is equipped with a three pronged (grounding) plug for your protection against shock hazard and should be plugged directly into a properly grounded three-prong receptacle. Do not cut or remove the grounding prong from this plug.

IMPORTANT
Disconnect power supply
before servicing

REMOVING VALVE

If your valve requires maintenance or replacement, use the following instructions:

Note: Always close off the gas supply before removing the valve.

- 1) If optional fan is installed, disconnect power source to stove.
- 2) Remove access panel.

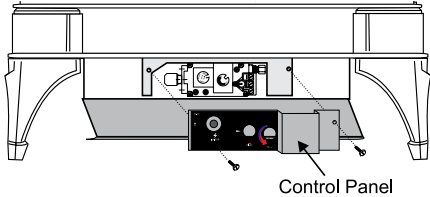

- 3) Disconnect gas line to stove.
- 4) Disconnect 3/8" NPT pipe from 90° elbow on valve or flex connector.
- 5) Disconnect the two (2) switch wires from valve.

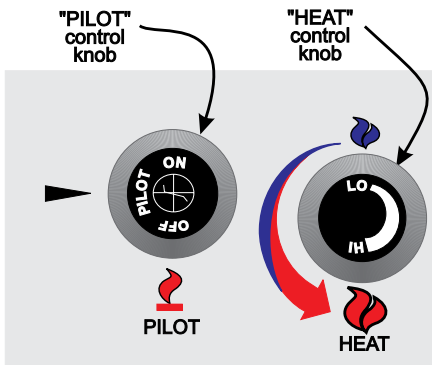

- 6) Disconnect piezo wire.
- 7) Lift off Cast Top, remove Cast Front and remove Glass Door. See the "Glass Replacement" section for removal instructions.
- 8) Carefully remove the logs and embers.

- 9) Remove burner by removing the 2 screws on each side, slide the burner to the left and then lift the burner tray out.

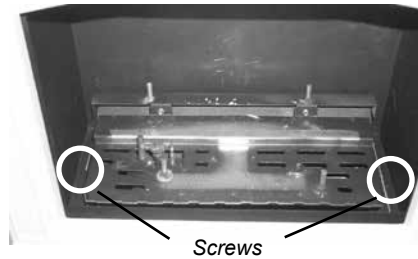

Note: Use a magnetic type screwdriver if possible.

- 10) Remove all 8 screws holding the burner tray assembly in place. Remove deflector.

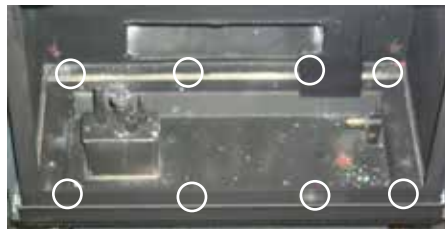

- 11) Carefully lift the burner tray assembly out.

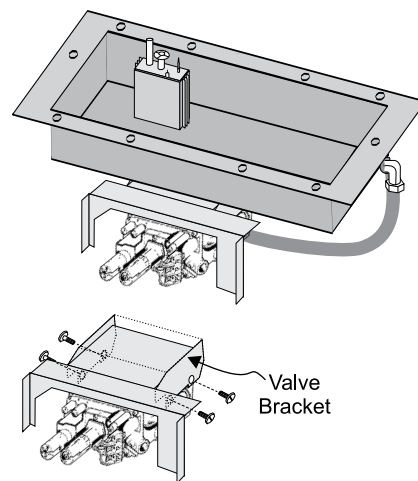

- 12) To remove the valve, remove the 4 screws (2 per bracket) that hold the valve to the valve bracket assembly.

- 13) To replace the burner tray assembly, simply reverse these instructions.

To remove valve from valve assembly, continue.

- 14) Remove two (2) thermopile wires.
- 15) Remove thermocouple with a 9 mm (metric) wrench.
- 16) Remove pilot nut with an 11 mm wrench.
- 17) Remove valve to orifice nut with a 13/16" wrench.
- 18) Remove inlet pipe with pipe wrench. Note orientation of 90° elbow.
- 19) Remove two (2) phillips head M5 screws on each side of the valve.
- 20) Remove valve and remove gas out 90° brass fitting. Note orientation of fitting.

INSTALLING VALVE ASSEMBLY

- 1) To install a new valve assembly, reverse instructions for **Removing Valve**.
- 2) Check for leaks and manifold pressure. See **Gas Pressure Test** instructions.
- 3) To reinstall valve, reverse instructions for removing valve assembly, steps 11-20.

PARTS LIST

MAIN ASSEMBLY

Part #	Description
1)	942-601** Casting - Top
2)	942-621** Casting - Side & Leg
3)	942-611** Casting - Front
6)	770-066F Top Relief Plate
7)	W260280 Top Relief Plate Gasket
8)	770-067F Plate Insulation Holder
9)	942-117 Top Relief Frame
10)	W260260 Top Relief Frame Gasket
11)	945F Dura-Vent Collar
12)	W842051 Gasket for Flue Adaptor
13)	W260108 Gasket for Inner Flue
14)	* Rear Bracket
15)	380-024 Fan Deflector - Right
16)	380-023 Fan Deflector - Left
17)	910-142 Thermodisc Switch

Part #	Description
20)	380-012 Rear Panel
25)	910-330 Fan Speed Control (120V)
26)	904-569 Knob - Fan Speed Control
28)	910-241 Burner ON/OFF Switch
29)	260-037 Rear Control Panel
35)	380-002 Firebox Bracket - Left
36)	380-003 Firebox Bracket - Right
38)	380-034 Casting Mount Bracket
45)	380-001 Door Support
46)	380-010 Baffle Plate of Firebox

Part #	Description
47)	380-011 Restrictor
50)	948-255 Latch Ojop W/J-Hook
51)	940-338/P Replacement Glass
52)	41225 Gasket Tadpole
53)	380-008 Glass Bracket
54)	380-007 Door Frame
56)	910-157/P Fan Motor (120 V)
57)	910-794 Power Cord (120 V)
	918-516 Manual

* Not available as a replacement part.

** Last digit of part number represents colour:
3=Slate Blue, 4=Ivory, 5=Timberline Brown,
7=Seaside Sand.

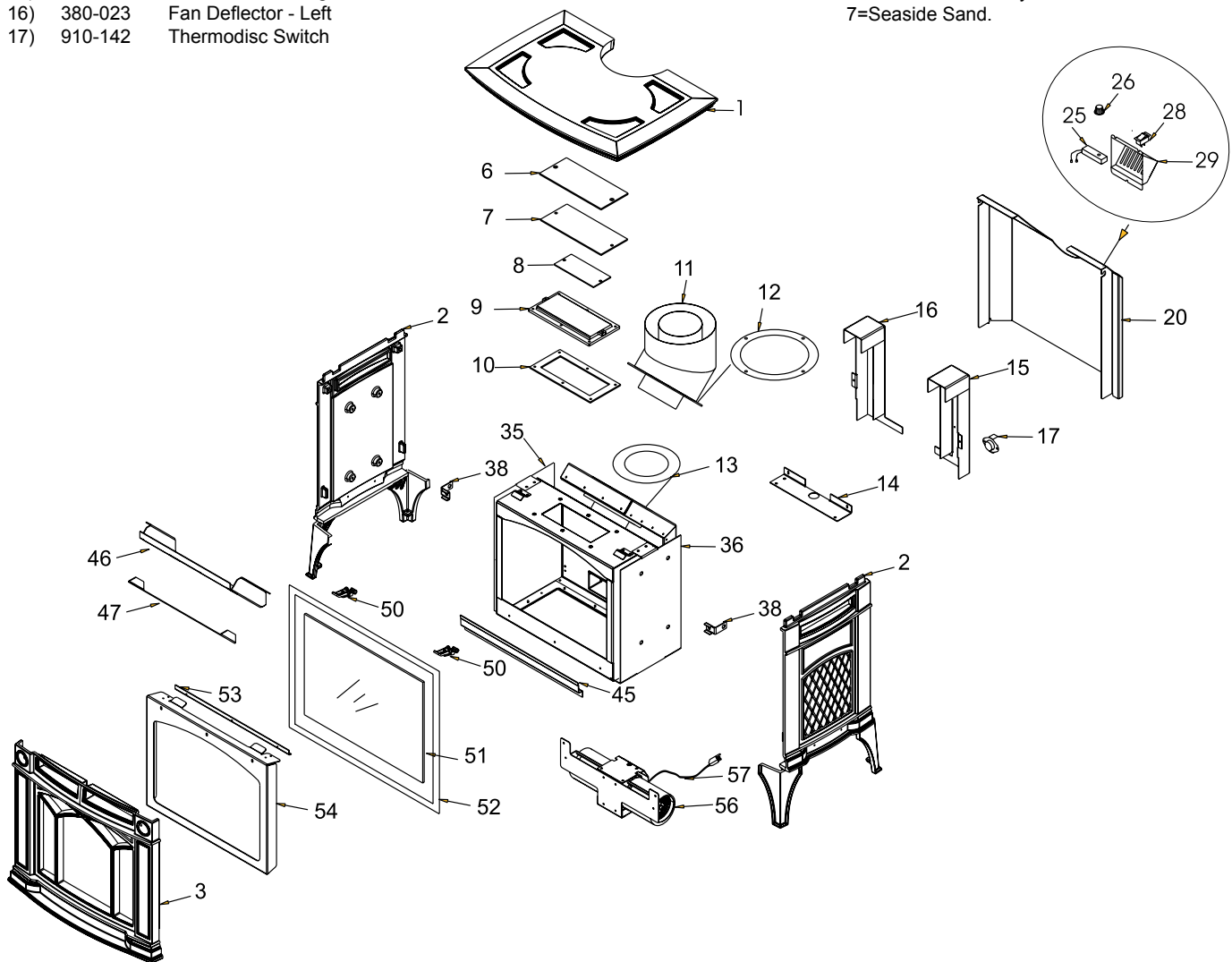

BURNER & LOG ASSEMBLY

Part #	Description
380-574/P	Valve/Pilot Assembly - S.I.T. - NG
60) 910-478	Valve S.I.T. - NG/LPG
904-434	#47 Orifice - NG
63) 910-190	Piezo Ignitor & Nut
64) 908-672	Control Panel Decal
65) 490-061	Switch Plate
936-170	Orifice Gasket
66) 910-038	Pilot Assy-S.I.T. - 3 flame - NG
910-039	Pilot Assy-S.I.T. - 3 flame - LP
67) 380-013	Pilot Holder
68) W840470	Pilot Assembly Gasket
69) 380-019	Valve Shield
73) 380-032	Valve Plate
74) 380-033	Valve Door
75) 380-930	Log Set
80) 380-505	Burner Assembly - NG
88) 380-015	Burner Box Gasket
89) *	Air Shutter
90) *	Burner Box
381-969	Conversion Kit - NG to LP

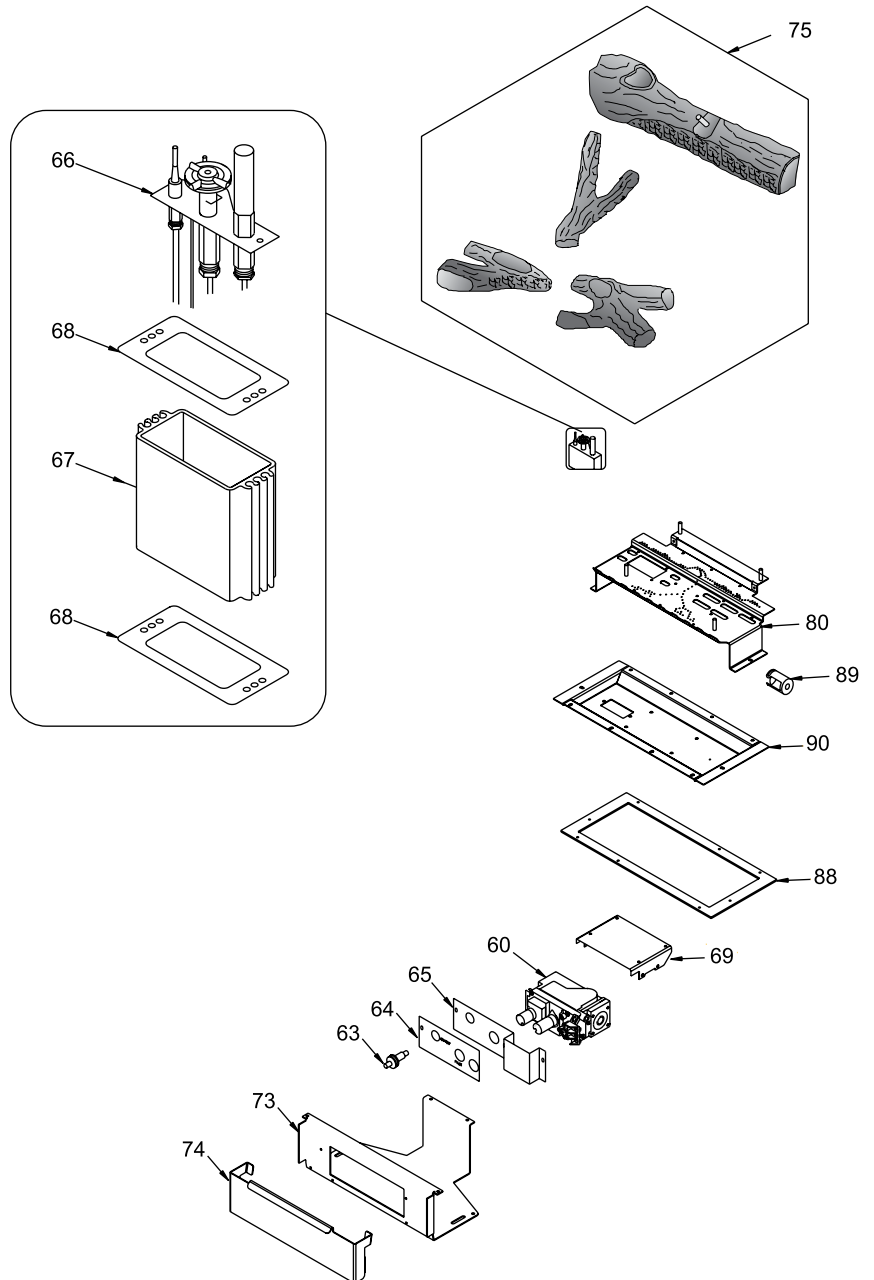



Hampton Fireplace Products are designed with reliability and simplicity in mind. In addition, our internal Quality Assurance Team carefully inspects each unit thoroughly before it leaves our facility. FPI Fireplace Products International Ltd. is pleased to extend this limited lifetime warranty to the original purchaser of a Hampton Product. This warranty is not transferable.

The Warranty: Limited Lifetime

External casting, not directly in contact with the fire, such as hobs, sides, ash lips, legs, fronts and fire doors, are covered against cracks and warps resulting from manufacturer defects, parts and subsidized labour* for three (3) years from the date of purchase and parts only thereafter.

The combustion chamber, heat exchanger, burner tubes/pans and logs are covered under the Limited Lifetime Warranty for five (5) years for parts and subsidized labour* and parts only thereafter.

Glass is covered for lifetime against thermal breakage only, parts and subsidized labour* for five (5) years and parts only thereafter from date of purchase.

Electrical and mechanical components such as blowers, switches, wiring, thermodiscs, FPI remote controls, spill switches, thermopiles, thermocouples, pilot assembly components, and gas valves are covered for two years parts and one year subsidized labour* from the date of purchase. Blowers and valves replaced under warranty are considered repairs and continue as if new with appliance. ie. twelve (12) months from original purchase date of appliance with a minimum of three (3) months coverage from date of replacement.

FPI venting components are covered parts and subsidized labour* for three (3) years from date of purchase.

Simpson Dura-Vent venting components are covered by Simpson Dura-Vent Inc. warranty.

Repair/replacement parts purchased by the consumer from FPI after the original coverage has expired on the unit will carry a 90 day warranty, valid with a receipt only. Any item shown to be defective will be repaired or replaced at our discretion. No labor coverage is included with these parts.

Conditions:

Porcelain/Enamel - Absolute perfection is neither guaranteed nor commercially possible. Any chips must be reported and inspected by an authorized dealer within three days of installation. Reported damage after this time will be subject to rejection.

Any part or parts of this unit which in our judgement show evidence of such defects will be repaired or replaced at FPI's option, through an accredited distributor or agent provided that the defective part be returned to the distributor or agent Transportation Prepaid, if requested.

It is the general practice of FPI to charge for larger, higher priced replacement parts and issue credit once the replaced component has been returned to FPI and evaluated for manufacturer defect.

The authorized selling dealer is responsible for all in-field service work carried out on your Hampton product. FPI will not be liable for results or costs of workmanship from unauthorized service persons or dealers.

At all times FPI reserves the right to inspect product in the field which is claimed to be defective.

All claims must be submitted to FPI by authorized selling dealers. It is essential that all submitted claims provide all of the necessary information including customer name, purchase date, serial #, type of unit, problem, and part or parts requested, without this information the warranty will be invalid.

Exclusions:

This limited Lifetime Warranty does not extend to or include paint (charcoal units), porcelain (including pinholes, scratches and minor shade mismatch), door or glass gasketing or trim.

At no time will FPI be liable for any consequential damages which exceed the purchase price of the unit. FPI has no obligation to enhance or modify any unit once manufactured. ie. as products evolve, field modifications or upgrades will not be performed.

FPI will not be liable for travel costs for service work.

Installation and environmental problems are not the responsibility of the manufacturer and therefore are not covered under the terms of this warranty policy.

Embers, door and glass, gaskets, door handles, paint are not covered under the terms of this warranty policy.

Any unit which shows signs of neglect or misuse is not covered under the terms of this warranty policy.

The warranty will not extend to any part which has been tampered with or altered in any way, or in our judgment has been subject to misuse, improper installation, negligence or accident, spillage or downdrafts caused by environmental or geographical conditions, inadequate ventilation, excessive offsets, negative air pressure caused by mechanical systems such as furnaces, fans, clothes dryer, etc.

Freight damage to stoves and replacement parts is not covered by warranty and is subject to a claim against the freight carrier by the dealer.

FPI will not be liable for acts of God, or acts of terrorism, which cause malfunction of the appliance.

Performance problems due to operator error will not be covered by this warranty policy.

Products made or provided by other manufacturers and used in conjunction with the operation of this appliance without prior authorization from FPI, may nullify your warranty on this product.

Any alteration to the unit which causes sooting or carboning that results in damage to the interior / exterior facia is not the responsibility of FPI.

* Subsidy according to job scale as predetermined by FPI.

Register your Regency® warranty online www.regency-fire.com

Reasons to register your product online today!

- View and modify a list of all your registered products.
- Request automatic email notification of new product updates.
- Stay informed about the current promotions, events, and special offers on related products.



H15 Product Video

Installer: Please complete the following information

Dealer Name & Address: _____

Installer: _____

Phone #: _____

Date Installed: _____

Serial No.: _____