



REGENCY[®]
FIREPLACE PRODUCTS

Ei25

**LED Electric Fire Range
with Thermostatic Remote Control**



Instructions for Use, Installation & Servicing For use in AU & NZ (Australia & New Zealand)

IMPORTANT

PARTS OF THE OUTER CASING OF THIS APPLIANCE ARE CONSIDERED BY THE MANUFACTURER TO BE A WORKING SURFACE WHICH BECOMES HOT WHEN THE HEATER IS IN OPERATION AND WILL RESULT IN SERIOUS INJURY AND BURNS IF TOUCHED. IT IS THEREFORE RECOMMENDED THAT A FIREGUARD IS USED IN THE PRESENCE OF YOUNG CHILDREN, THE ELDERLY OR INFIRM.

**THE HEATER OUTLET GRILLE BECOMES VERY HOT WHILST IN OPERATION.
DO NOT COVER THE OUTLET GRILLE OR ANY PART OF THE APPLIANCE.**

For use with 230V 50Hz electricity supply only.
Please read these instructions carefully before installation and keep them in a safe place.
They will be needed when maintenance or servicing is required.

THIS APPLIANCE MUST BE EARTHED

THIS PRODUCT IS ONLY SUITABLE FOR WELL INSULATED SPACES AND OCCASIONAL USE.

CONTENTS

Ei25 - LED Electric Fire Range

Covering the following models:

Ei25
210-430

User Instructions.....3

Installation Instructions.....9

 Servicing Requirements 10

 Technical Specifications 11

 Installation 12

 Accessing the Fuel bed..... 14

 Log Layout..... 17

Servicing Instructions.....20

 Pairing The Remote Control.....20

 Removing the Internal Components.....20

Wiring Diagram.....32

Spare Parts List.....33

Information Requirement.....34

Warranty - Australia35

WARRANTY

**This system carries a 2 years parts-labour warranty.
Please note that all warranties are effective from the date of purchase.**



Tested to AS/NZS 60335.2.30:2015 &
AS/NZS 60335.1:2011
Certificate Number SAA-241402-EA

USER INSTRUCTIONS

IMPORTANT INFORMATION AND HEALTH AND SAFETY

Read all of the instructions carefully before using the appliance.
Remove all packaging and dispose of at an appropriate recycling facility.

Do not locate this appliance immediately below a fixed socket outlet.

Parts of the outer casing of this appliance are considered by the manufacturer to be a working surface which becomes hot when the heater is switched on. You must use a suitable fire guard to protect children, the elderly and the infirm.

Do not use this appliance in the immediate surroundings of a bath, shower, swimming pool or any other area where the appliance could come into contact with water or humidity, e.g. a bathroom.



WARNING! DO NOT COVER

Do not allow the appliance to be covered or let the air inlet/outlet become obstructed as the appliance may overheat. Please note the warning symbol on the appliance (see above).

For indoor use only. This appliance is not suitable for use outside the house.

This appliance must be installed in a purpose built studwork enclosure. Ensure the appliance is level and that furniture, curtains etc. are positioned no closer than 1m.

Where the electricity supply cable has to pass through a fire place, stone surround etc. ensure suitable rubber bushes are fitted at possible wear points.

If installed in an open fireplace, blank off the chimney to reduce the risk of a back draught which can cause the safety cut-out to operate.

Keep the power cord away from hot surfaces and hot conditions. Do not route the power lead in front of the appliance. When the fire has been installed the position of the plug must be accessible.

If the electricity supply cable is damaged do not use the appliance until it has been replaced. For safety reasons the replacement has to be carried out by a competent electrician.

CAUTION: In order to avoid a hazard due to inadvertent resetting of the thermal cut-out, this appliance must not be supplied through an external switching device, such as a timer, or connected to a circuit that is regularly switched on and off by the utility.

Do not operate the appliance if it is damaged.

Repairs of electrical appliances must only be performed by a suitably qualified person. Should the appliance fail to operate, or in case of any damage, please contact the retailer from whom the appliance was purchased.

This appliance can be used by children aged from 8 years and above and persons with reduced physical, sensory or mental capabilities or lack of experience and knowledge if they have been given supervision or instruction concerning use of the appliance in a safe way and understand the hazards involved. Children shall not play with the appliance. Cleaning and user maintenance shall not be made by children without supervision.

Children of less than 3 years should be kept away unless continuously supervised.

Children aged from 3 years and less than 8 years shall only switch on/off the appliance provided that it has been placed or installed in its intended normal operating position and they have been given supervision or instruction concerning use of the appliance in a safe way and understand the hazards involved. Children aged from 3 years and less than 8 years shall not plug in, regulate and clean the appliance or perform maintenance.

Caution: Some parts of this product can become very hot and cause burns. Particular attention has to be given where children and vulnerable people are present.

However Regency recommend:

This appliance is not intended to be used by persons under the age of 12, persons with reduced physical, sensory or mental capabilities or persons with lack of experience and knowledge in the safe operation of the appliance.

The appliance may be operated by persons above the age of 12 provided they have been instructed in the safe use of the appliance and that they understand the hazards involved. Persons above the age of 12 may also operate the appliance under the supervision of a responsible adult.

Parts of this appliance become hot whilst in operation and under no circumstances should persons under the age of 12 be left alone with the product when it is in operation unless a suitable fireguard is used to protect them against the possibility of coming into direct contact with the appliance.

Children shall not play with the appliance.

Cleaning and user maintenance shall not be made by children without supervision.

OPERATING INSTRUCTIONS



WARNING! Do not operate the appliance if it is damaged or has malfunctioned. If you suspect the appliance is damaged or has malfunctioned call a suitably quality person to inspect the appliance, and replace any part of the electrical system if necessary, before reuse.

Do not disconnect the power at the mains supply **whilst the appliance is running**. Use the functions on the remote to turn the fire off and ensure the mains switch has been moved to the off position before disconnecting.

MANUAL CONTROL PANEL

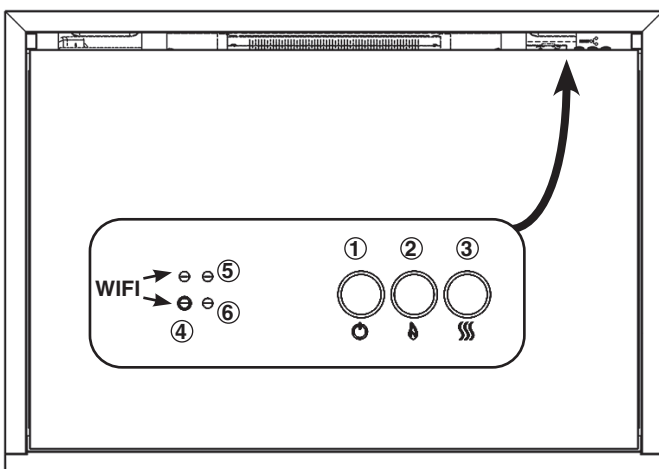

1. Flame On/Off and heater Off.
2. Flame On/Off button.
3. Heater On/Off.
4. Press to connect or disconnect the network. The indicator light will illuminate when the WIFI is turned on.
5. Heater running indicators.
6. Remote Reset Button.

Note: To deactivate the beeping/audible sound, press and hold in the FLAME button on the manual control panel for 3 seconds. To reactive the beeping, repeat same steps.

OPERATING THE APPLIANCE

Press 1 to turn the appliance on/off.
Press 2 to turn flames on/off.
Press 3 to turn the heater on/off.



NOTE: To use both remote and manual functions the manual on/off switch must be in 'ON' position. To prevent the product overheating, there is a 10s delay when turning on and off the heater fan.

The manual button controls basic functions.
Use the remote hand set to carry out all functions.

REMOTE CONTROL

The remote control should be left on a flat surface in the room where the appliance is installed and away from any direct flow of hot air.

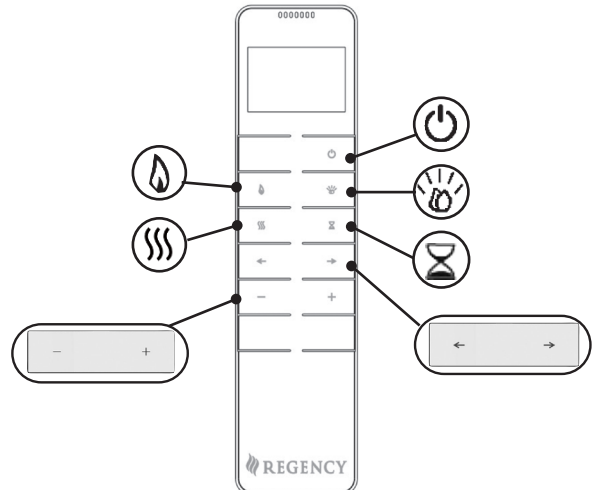

- Power On/Off

- Heater

- Flames

- Fuel Bed

- Timer

- Colour option

- Levels

OPERATING THE APPLIANCE - QUICK START



Turn the Appliance On/Off

The appliance will start on the last remembered setting.



Turn the Heater On/Off.



- Increase or decrease the heat output.



Turn the Flame Effect On/Off.



- Increase or decrease the brightness level.



Turn the Fuel Bed Effect On/Off.

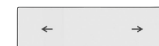

- Change the colour option.

There are fourteen fuel bed colour options:



- Increase or decrease the brightness level.



- Set a Timer

Press the button to set the timer. The Timer can be set at 0.5H, 1.0H, and then each hour up to 10.0H.

OPERATING THE APPLIANCE - ADVANCED OPERATION

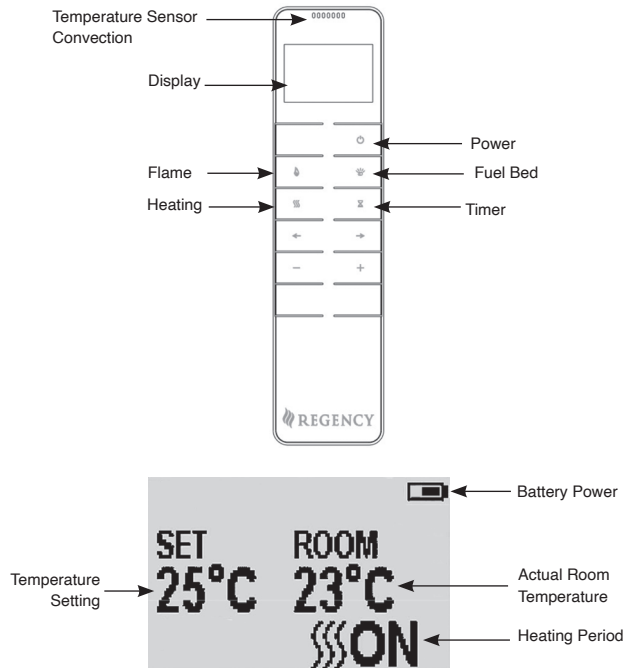

TURN ON/OFF

Press button to turn on the flame effect.

Press button to turn off all the functions.

FLAME COLOUR ADJUSTMENT

Press button.

There are 5 levels of brightness.



Press the '+' button to increase the flame brightness.

Press the '-' button to decrease the flame brightness until off.

FUEL BED COLOUR ADJUSTMENT

Press to enter the fuel bed light adjustment screen.

There are 15 fuel bed colour options, including off.

There are 5 levels of brightness.

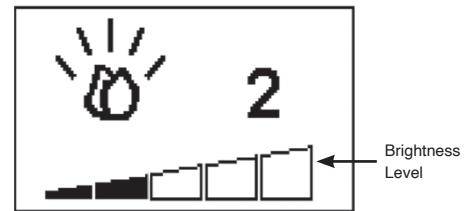

Press the '←' or '→' button to cycle through the fuel bed colour options.

Press the '+' button to increase the fuel bed brightness.

Press the '-' button to decrease the fuel bed brightness until off.

COUNT DOWN TIMER

This setting is only in normal heating control mode. It allows the appliance to be returned to Standby after a set period of time. The heater must be switched on to use this function.

Press to cycle through the setting from Off and 0.5 hours to 9 hours. Timer logo and remaining time will show on the screen.

The heater of appliance can be automatically run by using daily timer.

CHANGE THE TEMPERATURE SETTING BETWEEN C° & F°

Press button to turn on the remote.

Press the '←' or '→' button for 3 seconds to change the temperature scale between C° and F°.

Press the power button to save.



ADAPTIVE START CONTROL

The heater will automatically determine the appropriate time to heat to ensure that it will reach the set-pointed temperature at the set time (up to 45 minutes prior to the set time).

OPERATING THE APPLIANCE - TROUBLESHOOTING

BATTERY

The battery power level is indicated at the top right of the remote control screen.

	Battery Full	No action required
	Battery Half Power	Ensure new batteries are available.
	Battery Empty	Replace batteries immediately

i **NOTE:** The remote control has a Battery Status indicator (top right corner), after an extended period of displaying empty the LED screen will cease to function despite the handset still being able to send commands. Replace the batteries to restore display.

BATTERY REPLACEMENT

Exhausted batteries are to be removed from the appliance and safely disposed of.

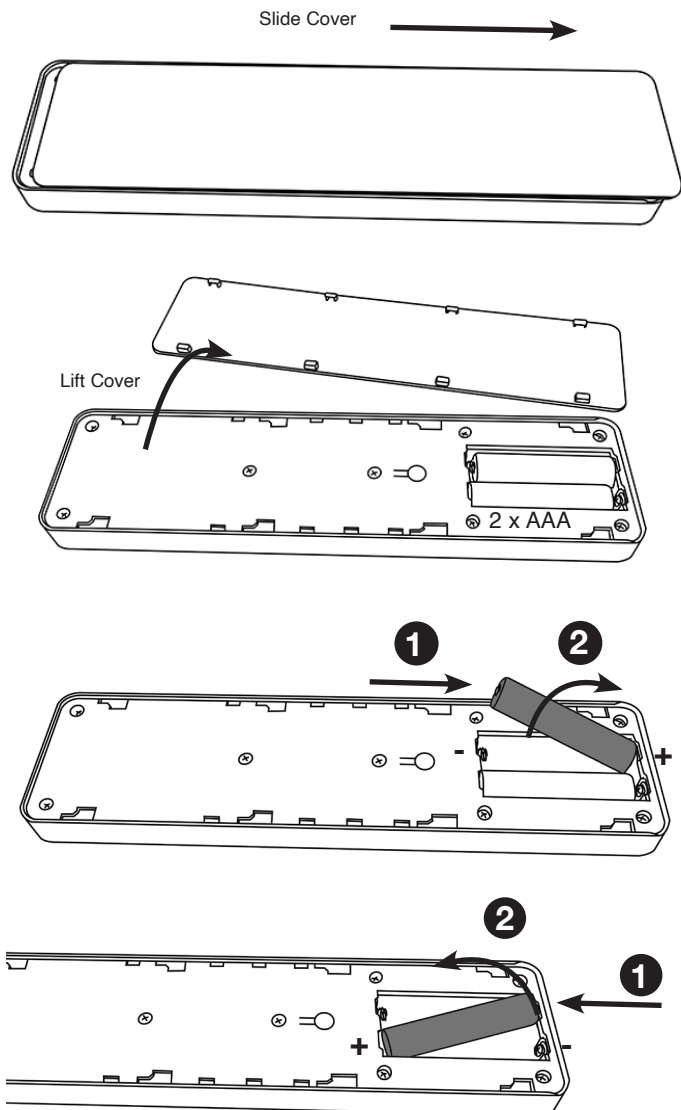

Ensure that the handset batteries are new and inserted correctly.

Dispose of old batteries at an appropriate recycling facility.

Battery replacement is recommended after 1 year. The Remote requires two 1.5V alkaline AAA batteries.

Ensure the correct polarity. Do not short circuit the terminals.

Do not attempt to recharge non-rechargeable batteries.

Remove rechargeable batteries before charging.

Do not mix old and new batteries.

Remove batteries if the appliance is not used for long periods.

Changing the batteries will not affect the Timer settings.

i **NOTE:** To use both remote and manual functions the manual on/off switch must be in 'ON' position. In order to prevent the product becoming too hot, there is 10s delay when turning on the heater and a 10s delay when turning off the heater fan.

The manual button controls basic functions, not a full range of controls. Use the remote hand set to carry out all functions.(?)

HEATER RUNNING INDICATORS

When the fan heater is used in conjunction with the flame or fuel bed effects the heater running indicators will light up for 10 seconds.

The LEDs will illuminate for 10 seconds if the flame or fuel bed effect is On.

If the fan heater is used independently, the heater running indicators will stay on.

RESET BUTTON FOR REMOTE CONTROL

If the handset loses signal or needs to be replaced then, see Servicing Instructions for details.

SIGNAL CODE

The handheld transmitter is configured in the factory with a unique signal code.

IMPORTANT: If the handset loses signal or needs to be replaced, see Servicing Section for details.

MAINTENANCE

ENSURE THE APPLIANCE IS TURNED OFF BEFORE CLEANING.

GLASS CLEANING

Wipe the glass viewing panel with a damp cloth and buff with a lint free duster.

Caution: Do not use abrasive cleaners on the glass panel. Do not spray liquids directly onto any surface of the unit.

CLEANING THE FUEL EFFECT

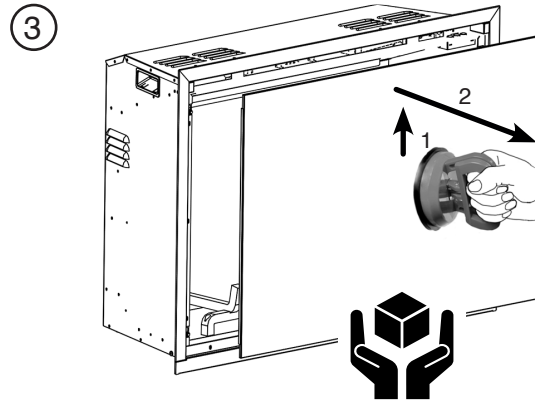
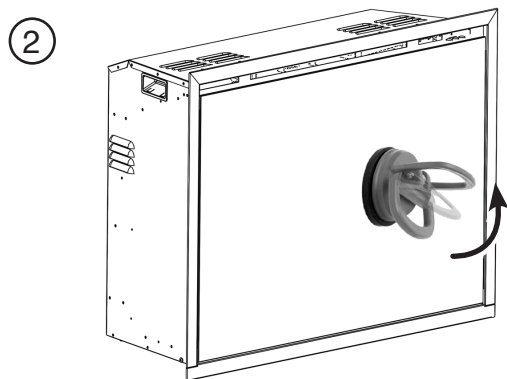
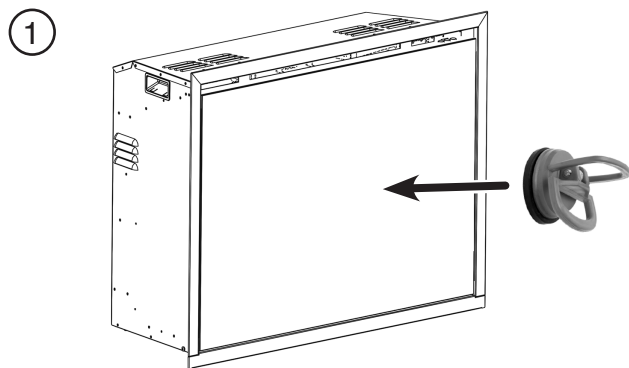

Remove and wash the fuel effect to remove any dust particles. Alternatively clean with a lint free duster.

Ensure that the effect is dry before replacing.

Replace the fuel effect see Installation Instructions, Log Layout.

Replace in reverse order.

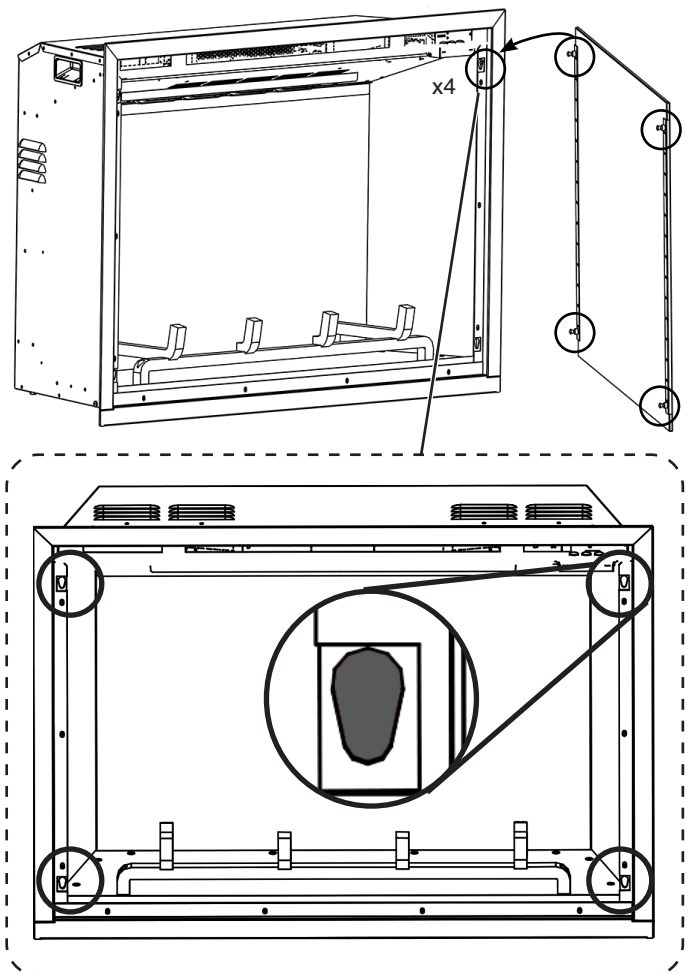

CLEANING AIR INLETS

Clean the air inlet and outlet grilles regularly with a soft cloth or the nozzle of a vacuum cleaner.

Dust build-up can inhibit efficient performance of the fan and lead to the safety cut-out operating.

Keep the area around the appliance clean and free of fluff, dust or pet hair.

In particular, build-up of dust etc. can occur around the heater area. Take particular care to keep this area free from such particles on a regular basis to prevent build-up.

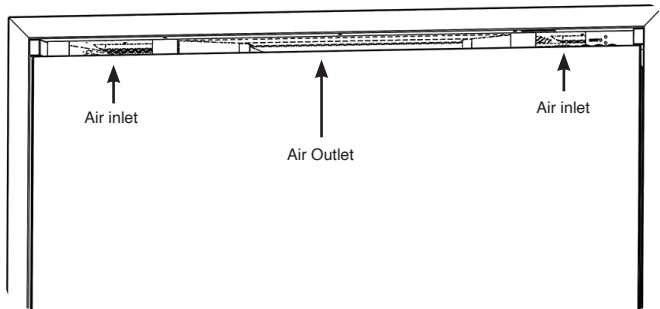

INSTALLATION

GENERAL

TOOLS REQUIRED

A Screwdriver, Spirit Level and Drill will be needed.

UNPACKING THE FIREPLACE

WARNING! DO NOT use this appliance if any part has been exposed to water.

Immediately call a qualified service technician to inspect and to replace any part of the electrical system if necessary.

Open the packaging carefully and remove the polystyrene. Remove and discard the plastic bag. Keep plastic wrapping away from children. Be responsible when handling the packing materials.

Check all parts and accessories are removed before disposing of any packaging. If necessary keep the original packaging for future transport and/or storage.

TEST THE APPLIANCE BEFORE INSTALLATION.

FITTING THE APPLIANCE

LOCATING THE Ei25

Your new Ei25 may be installed virtually anywhere in your home. However, when choosing a location ensure that the general instructions are followed.

For best results, install out of direct sunlight.

The heater should ideally be fitted into/onto an internal flat wall constructed from either studwork and plasterboard block/brick. The fixings provided are for use on brick walls ONLY. Please ensure that suitable fixings are used when securing to any hollow or purpose built cavity. This may also be installed into a masonry fireplace as long as it meets the requirements as per below.

NOTE: This appliance is not suitable for fitting to a Cavity Wall, backing on to an outside wall, an open chimney or any opening that may be subject to damp and draft, unless adequate precautions are taken to avoid the appliance coming into contact with moisture or excessive drafts.

Into Framed construction: For exterior/outside walls, insulate the enclosure to the same degree as the rest of the house, apply vapor barrier and drywall, as per local building control requirements. Do not insulate the appliance itself.

Into masonry chimneys: The flue must be fully blocked if safe to do so for installation of the unit. Ensure the fireplace and chimney are clean and in good working order, and that all chimney clean-outs are tight-fitting and not permitting air into the chimney. Install a sealed vent cap and metal flashing at the top of the masonry chimney to prevent water leaks and air movement within the cavity. Do not insulate the appliance itself.

Make sure there are no pipes or cables behind the area to be drilled or cut.

Always ensure the appliance is adequately supported and sits on a firm structure when mounting above floor level.

The appliance should ideally be located close to a suitable mains socket to enable connection. An extension could be run from an existing socket outlet but this must be carried out by a suitably qualified electrical engineer.

The electrical socket must be easily accessible to allow disconnection when the appliance is fitted.

If the power cord is damaged, it must be repaired by the manufacturer, its authorised service centre or professional person.

Ensure that curtains and furniture are not positioned close to the chosen position, as this would create a potential fire hazard or block the heater outlet ducts.

WARNING! KEEP ALL COMBUSTIBLE MATERIALS AT LEAST 1M FROM THE FRONT OF THE ELECTRIC FIREPLACE.

SERVICING REQUIREMENTS



DURING SERVICING OF THIS APPLIANCE IT MAY BE NECESSARY TO CUT CABLE TIES IN ORDER TO ACCESS AND REMOVE SOME OF THE PARTS. THESE MUST BE REPLACED WHEN REASSEMBLING THE APPLIANCE.

THIS APPLIANCE MUST ONLY BE SERVICED BY A SUITABLY QUALIFIED PERSON.

BEFORE UNDERTAKING ANY WORK ON THE APPLIANCE: SWITCH OFF THE APPLIANCE AND ISOLATE THE POWER SUPPLY ENSURING THERE IS NO POWER TO THE APPLIANCE.

Wait for at least 10 minutes until the appliance has cooled down.

Remote Handset Battery Replacement

Replace with 2 AAA batteries. Make sure the batteries are installed correctly in the remote control.



**NOTE: The remote control has a Battery Status indicator (top right corner), after an extended period of displaying empty the LED screen will cease to function despite the handset still being able to send commands.
Replace the batteries to restore display.**

Maintenance of Motors

The motor used on the flame effect is pre-lubricated for extended bearing life and requires no further lubrication. However, periodic cleaning/vacuuming of the heater unit is recommended.

Resetting the Thermal Cutout Switch

The appliance is fitted with an Electronic Safety Control (E.S.). This is a safety device which switches off the fire if, the appliance overheats for any reason e.g. when covered.

If the heater stops operating whilst the flame effect continues normally, this indicates that the E.S. Control is in operation. The E.S. Control can only be re-set after the appliance has cooled down.

To re-set the E.S.:

Switch off the appliance (Manual On/Off switch) and leave for approximately 120 minutes.

Remove any obstruction to the fan heater outlet or other internal parts.

Switch on appliance and the E.S. Control will re-set. Ensure that the appliance is functioning correctly. If the E.S. Control operates again, the appliance should be checked by a competent Electrician.

TECHNICAL SPECIFICATION

Ei25

210-430

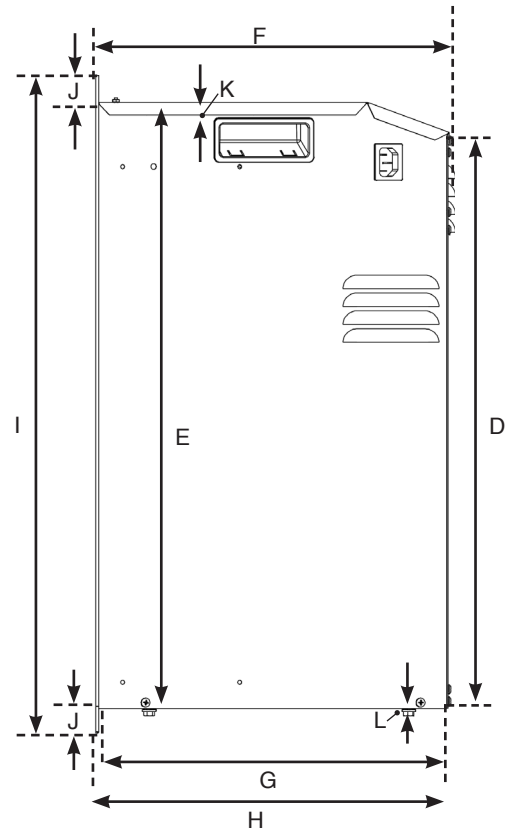
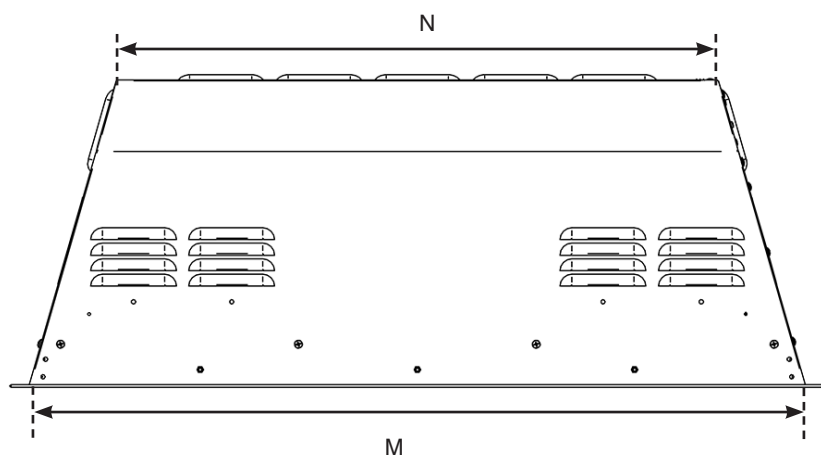
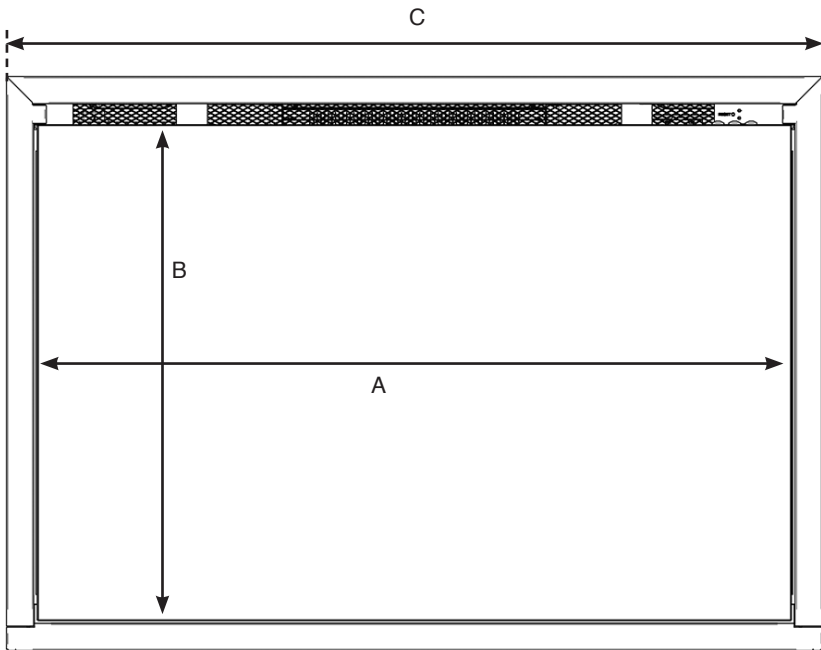

DIMENSIONS (mm)	A	B	C	D	E	F	G	H	I	J	K	L	M	N
Ei25	627	403	687	407	432	302	295	298	477	20	10.5	6	648	478

INSTALLATION

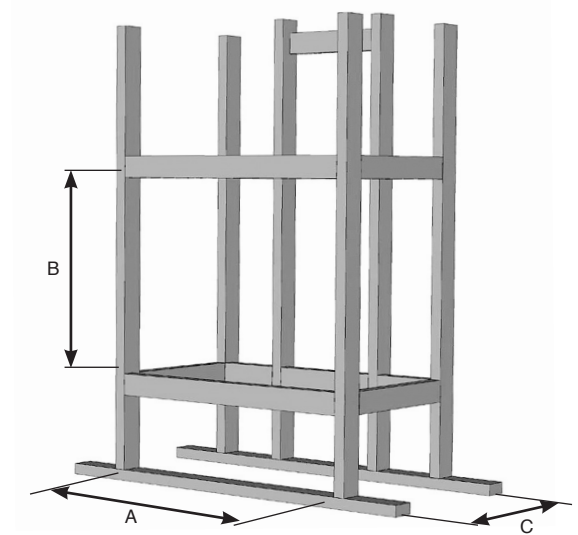
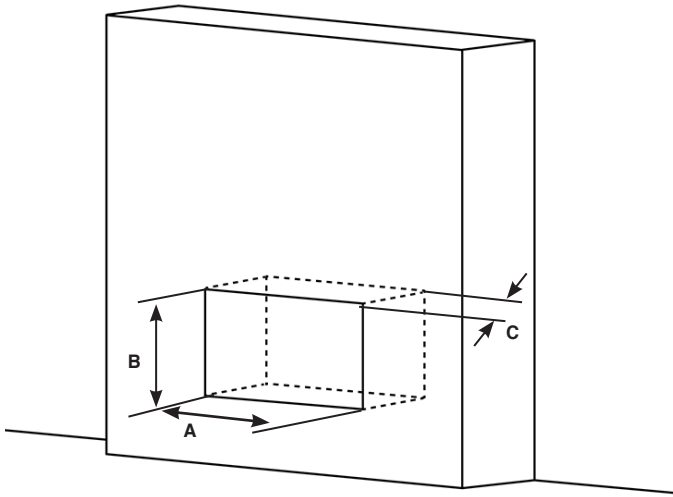

	A	B	C
Ei25	653mm	450mm	320mm

CONTROL SYSTEM TECHNICAL DATA

	MAIN CONTROL BOARD	REMOTE RECEIVER BOARD	REMOTE CONTROL
Hardware	RC01-086A V0	RF290I V1.2	RC290F V1.1
Software	RC01-086A01 V0	-	RCS19-V01.06
Frequency	-	-	FSK 433.92MHz
Maximum Transmit Power	-	-	10mW

Maximum power consumption:

Ei25	1830 - 2000 Watts
------	-------------------

A 230-240VAC 10 Amp 50Hz supply is required

This product must be earthed.

A 1.8 metre lead is supplied.

2 x Remote control handset battery (AAA).

PACKING CHECKLIST



x4



x1



x1



x2 (AAA)



x10 (ST4x8)

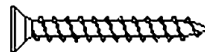

x4 (ST4x40)



x1



x1



x1



x1

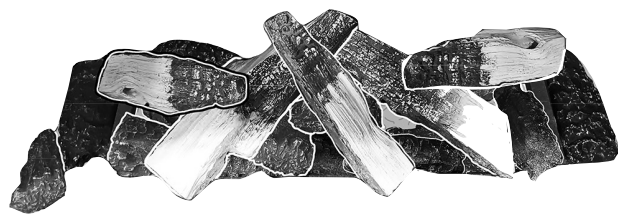

x1

ACCESSING THE FUEL BED

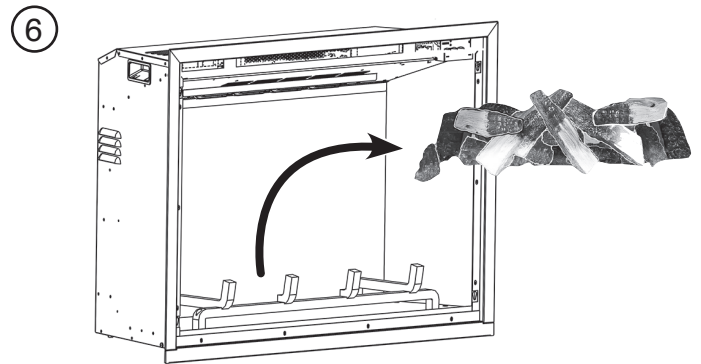
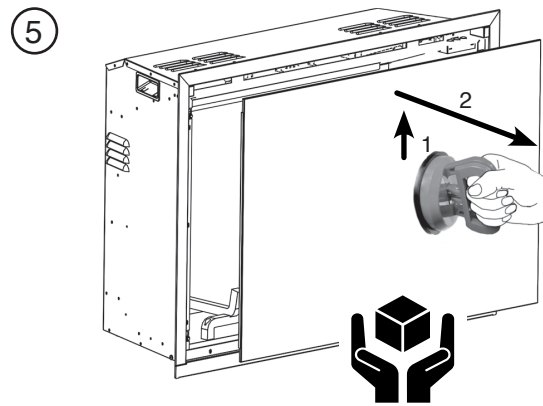
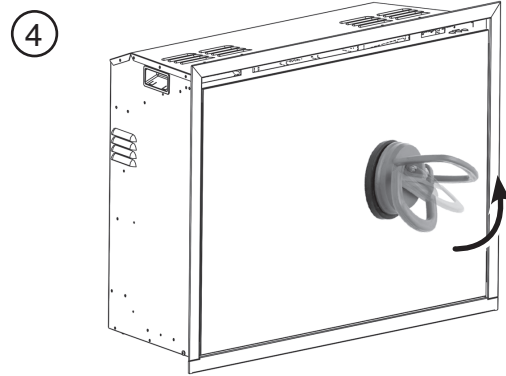
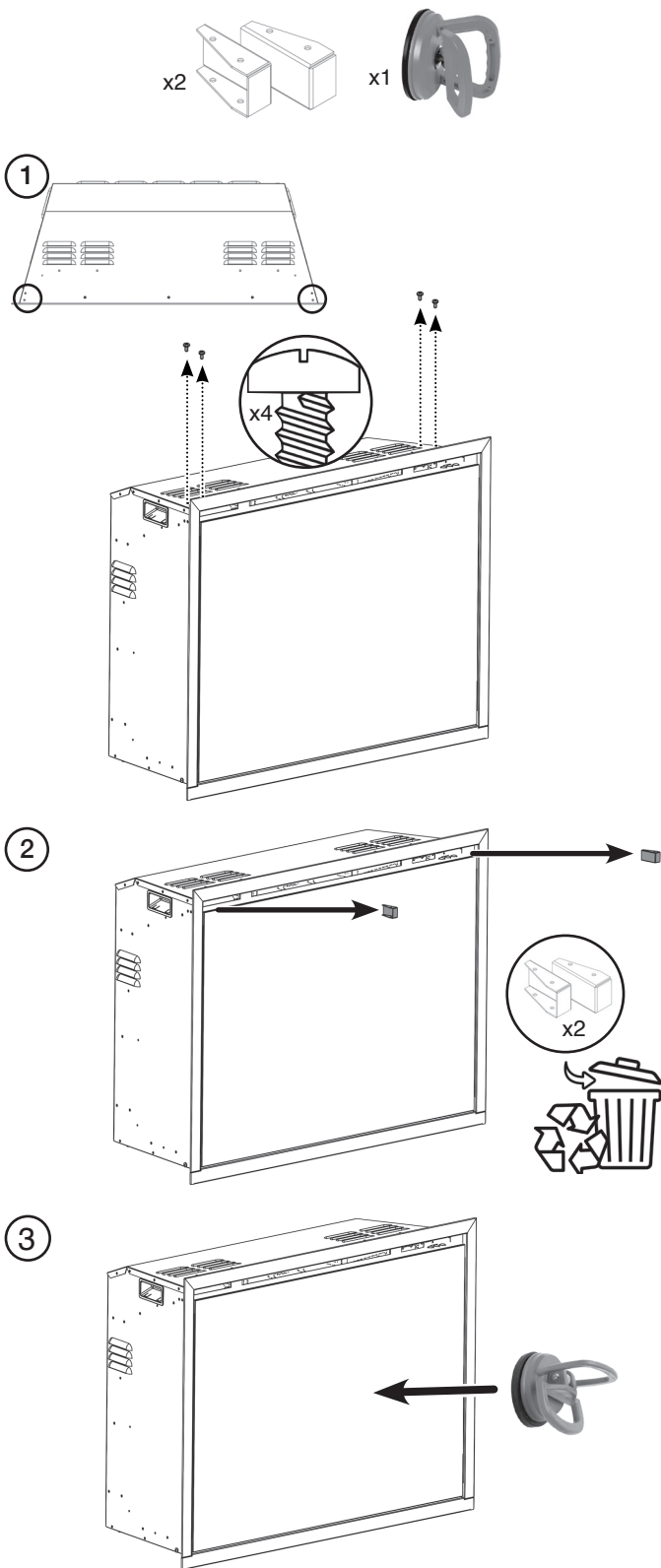

LEVELLING LEGS

NOTE: The levelling of the appliance must be done prior to sliding appliance into final position.

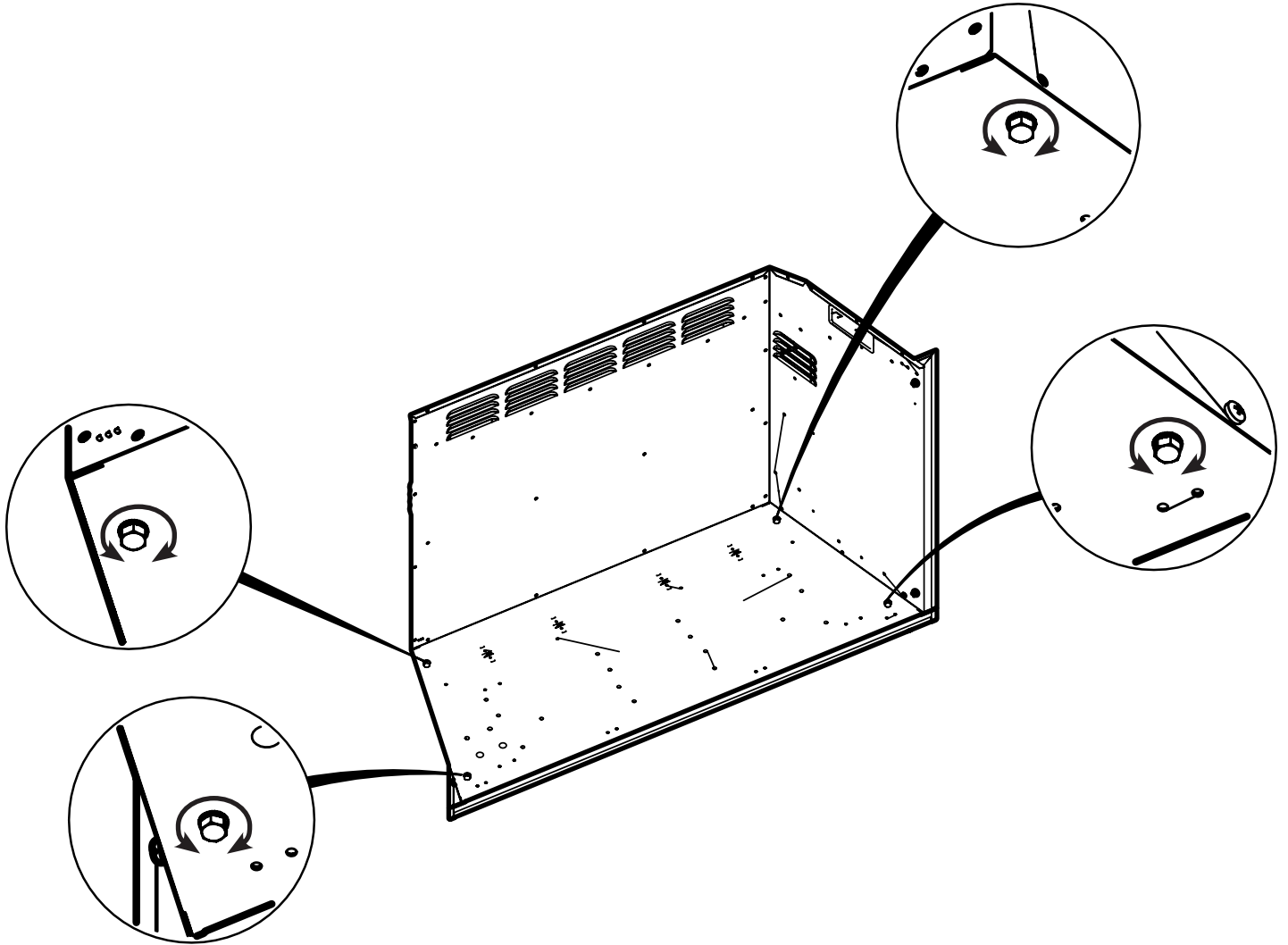

The leveling bolts which are supplied must be installed with bolts from below as shown. Rest appliance on its back and secure 4 bolts as shown above. Once it is in position, adjust the bolts to ensure the appliance is level and won't rock.

INSTALLATION

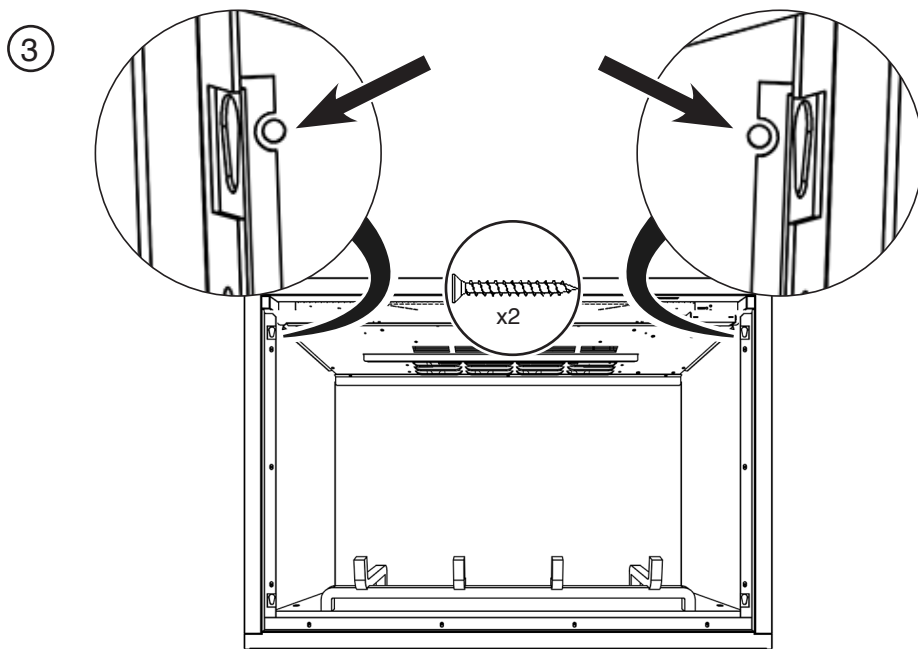
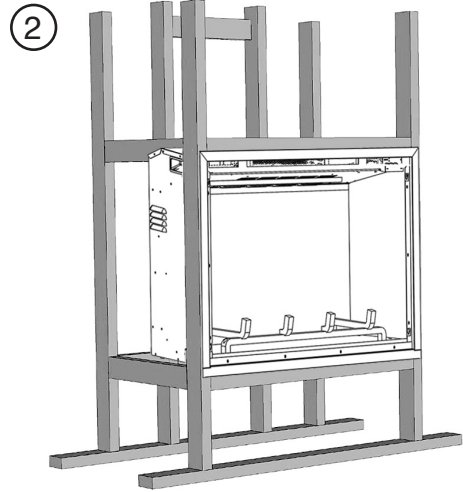
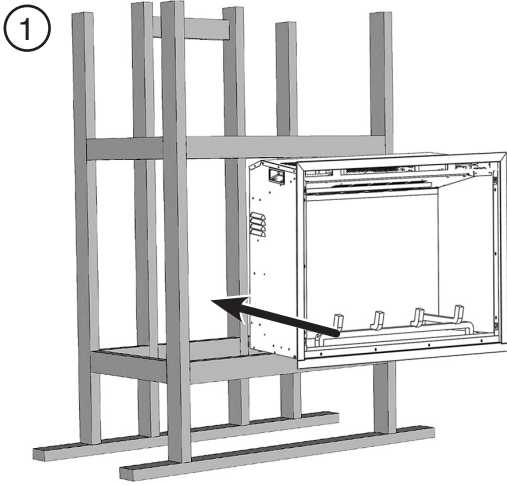

LOG SET - LOG LAYOUT

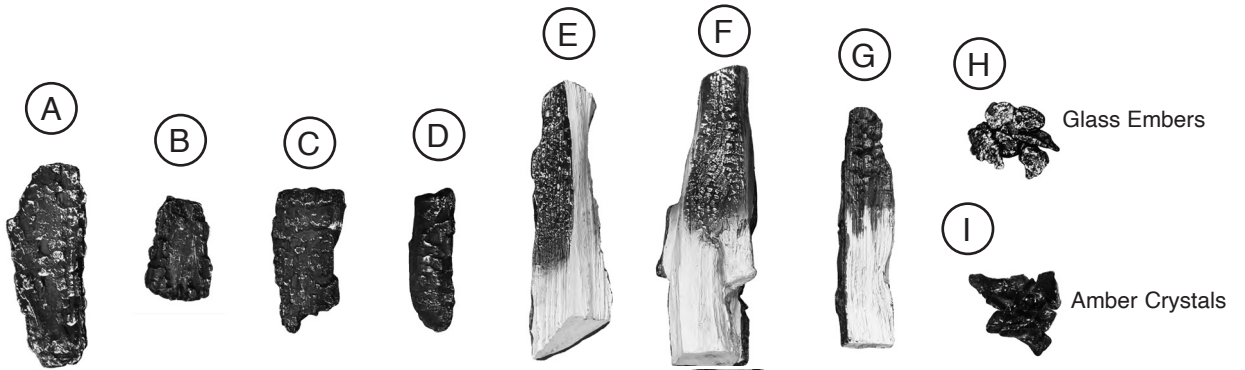

	A	B	C	D	E	F	G
Ei25	4	3	2	0	1	1	3

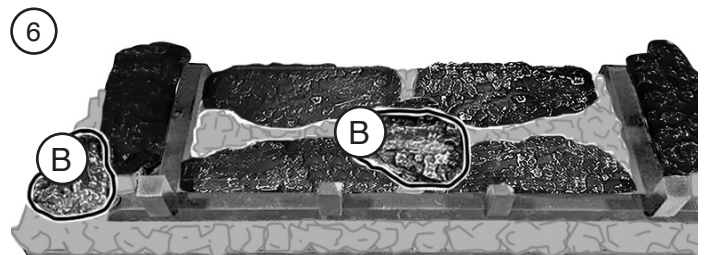
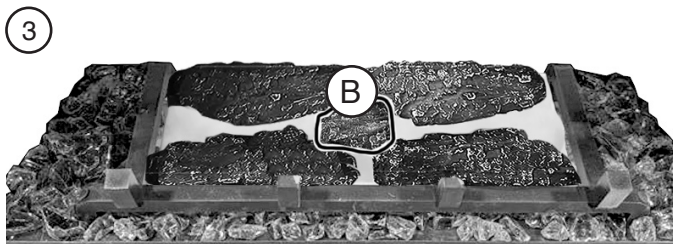
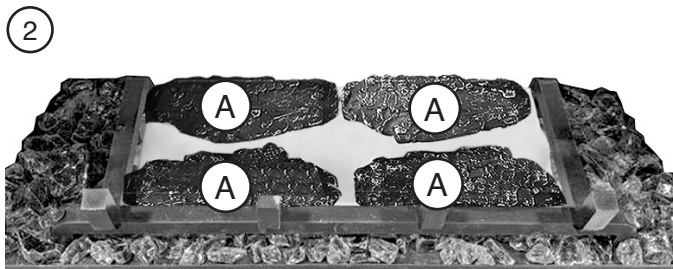
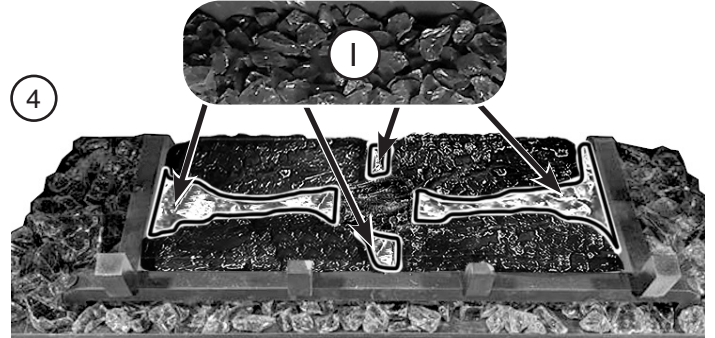
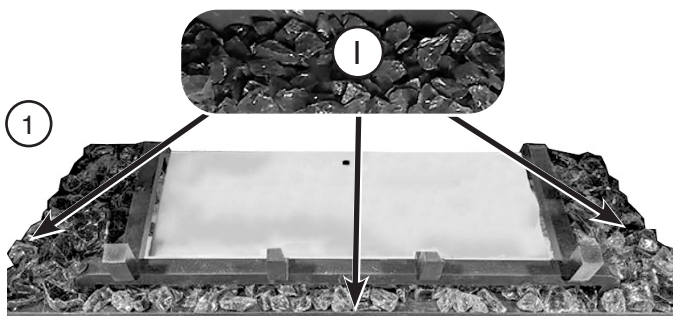

7 Place glass embers (H) evenly with white sides facing up.

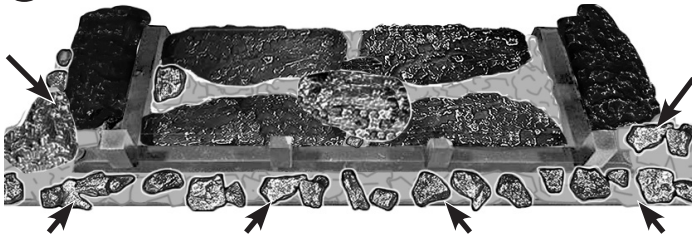

8 Apply tape to logs at white dot positions

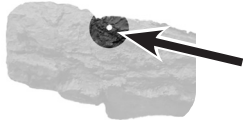

9 Adhesive Tape E x3

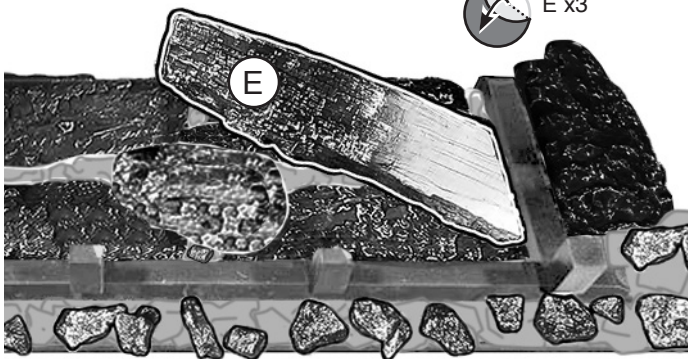

10 Adhesive Tape x1

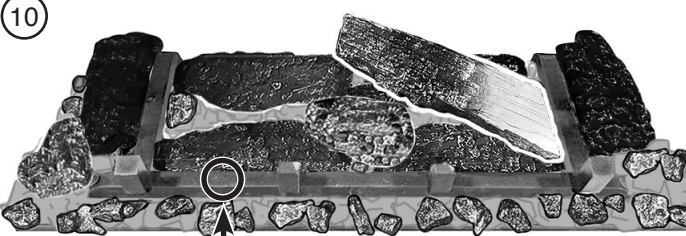

11 F x2
x1

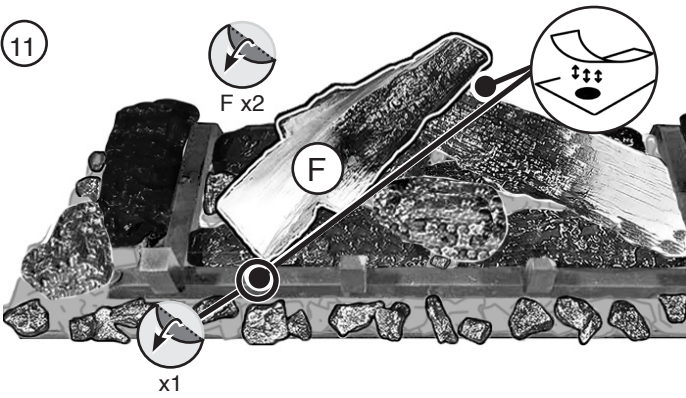

12



13

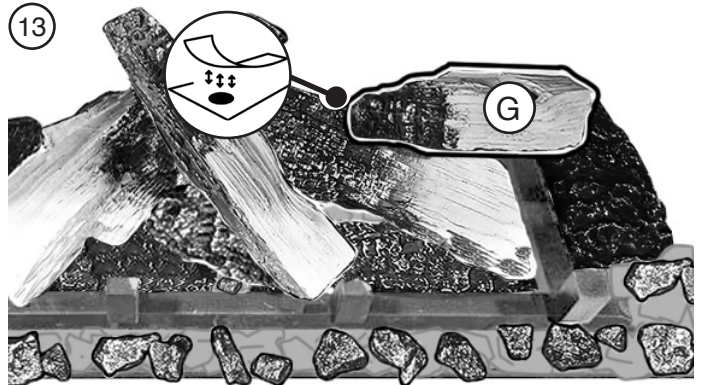

14

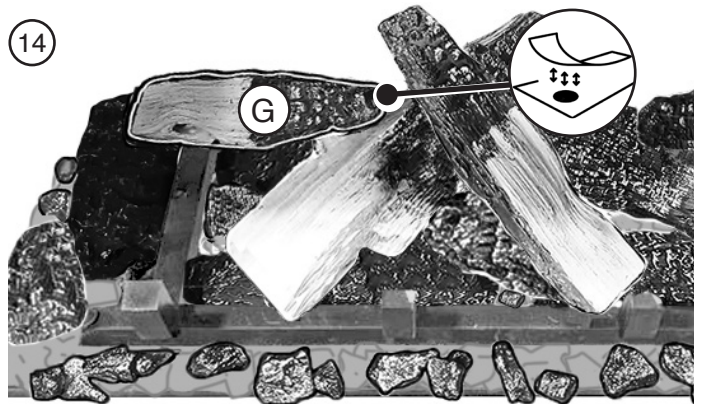

15



COMPLETION OF ASSEMBLY

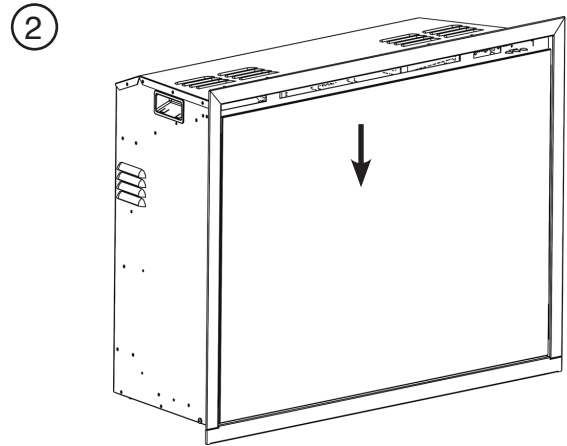
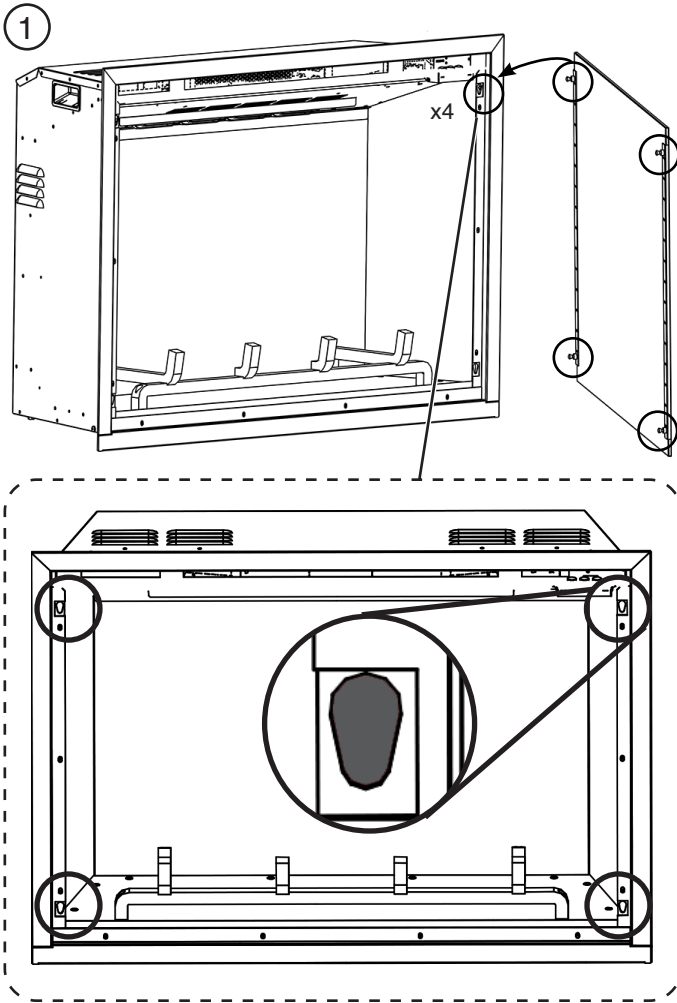

SERVICING

PAIRING THE REMOTE

SIGNAL CODE

The below operations should be carried out before coding when changing to a new remote or the unit cannot be controlled by the remote:

The reset button is located on the control panel located on the right-hand side of the appliance.

Press the reset button for 3 seconds (a pen point may be needed) until 3 short beeps sound from the unit, release the button.

Within 10 seconds, press the  button on remote. The coding is finished when 1 long beep sounds from the unit.

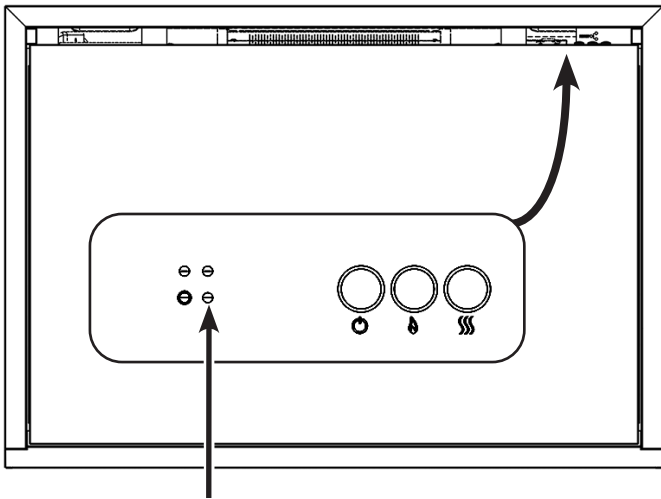

Reset Button for Remote Control

Resetting of the remote control is necessary if the appliance operates wrongly due to external interference signal and the remote control is not in use.

Open the back cover of the Remote.

Press the Reset button for 3 seconds and reset the coding.



ACCESSING THE FUEL BED

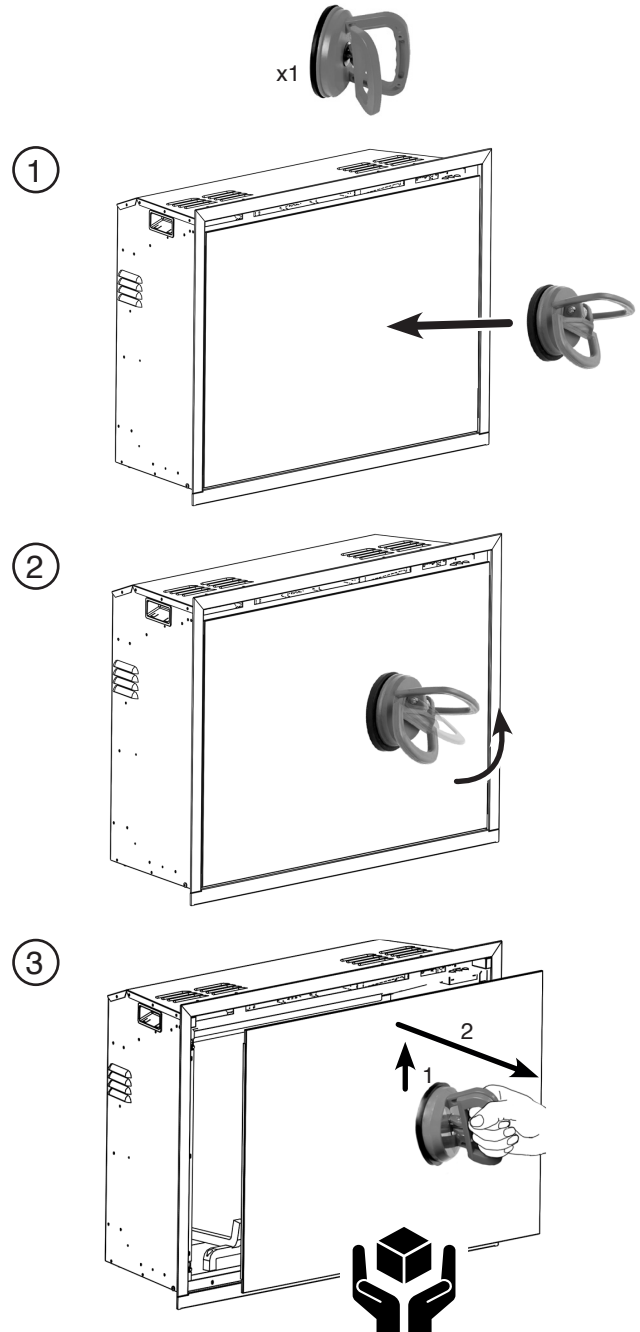

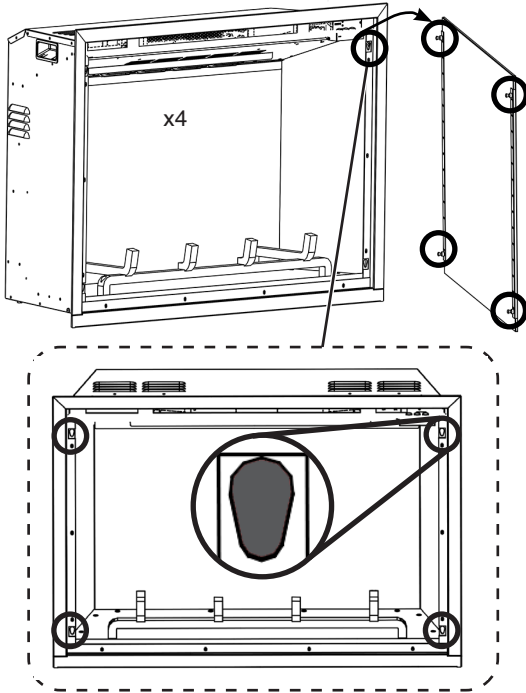

REMOVAL OF THE FUEL BED

Remove 4 rubber plugs using a small flat head screwdriver on grate (not shown) and then remove 4 screws (2 at back/2 at front) as shown below.

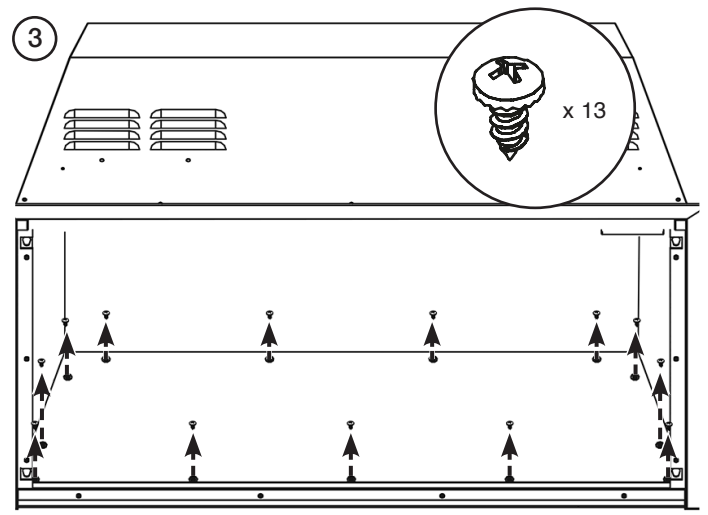
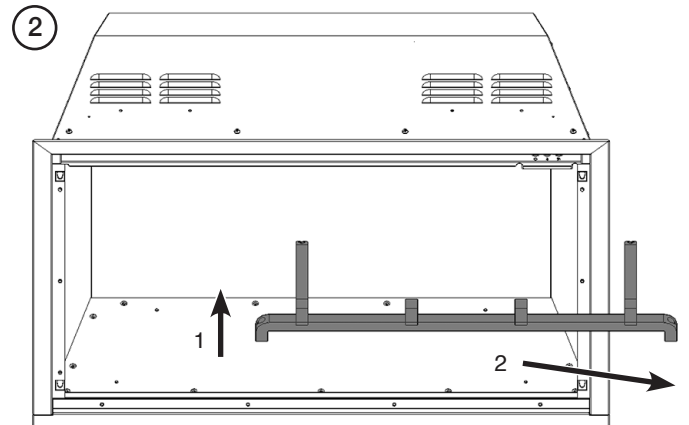
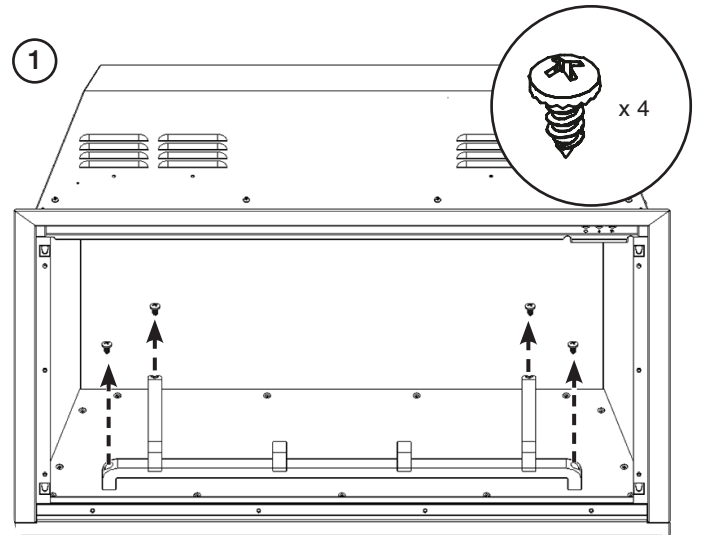

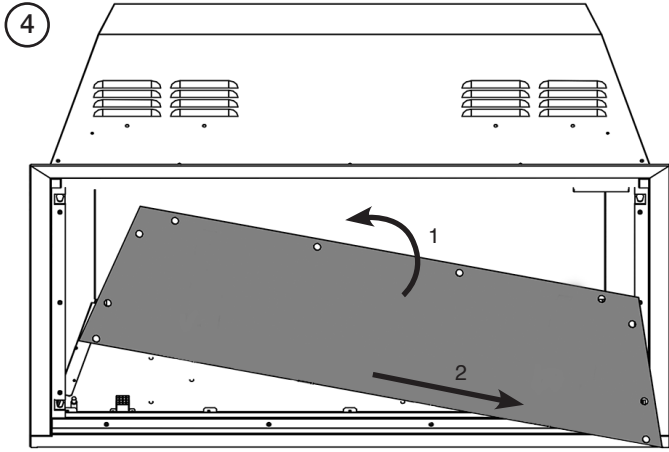

REPLACING THE FUEL BED LEDS

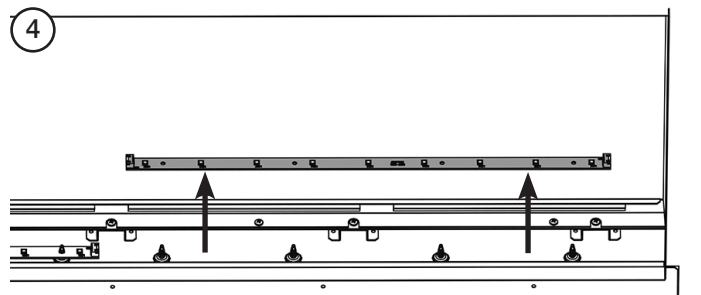
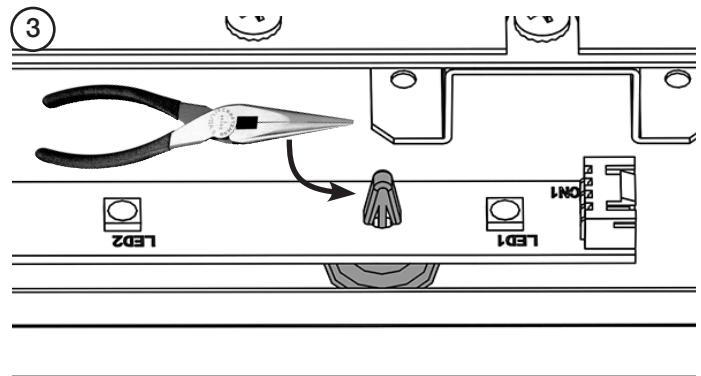
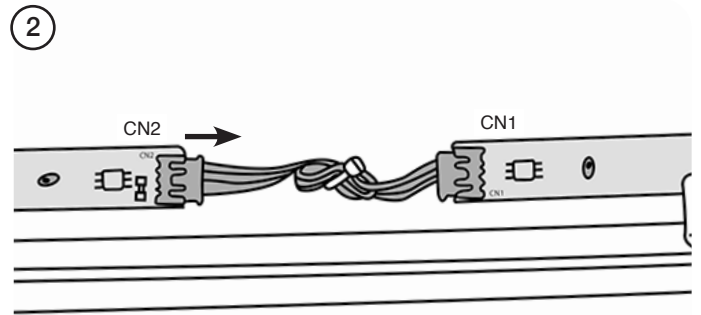
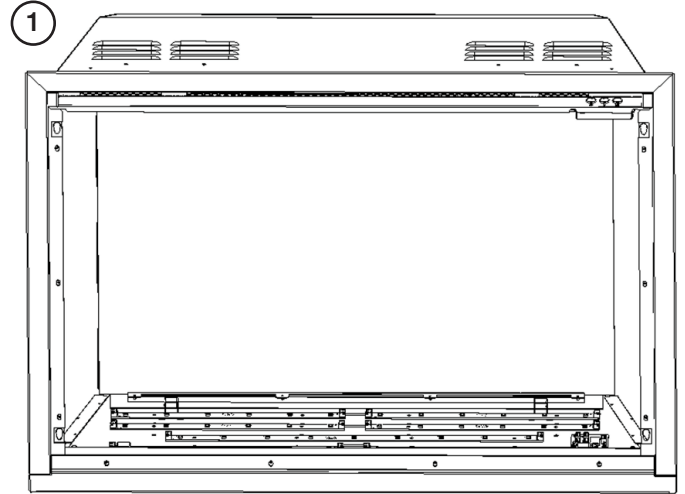

REPLACING THE LED LIGHT BAR

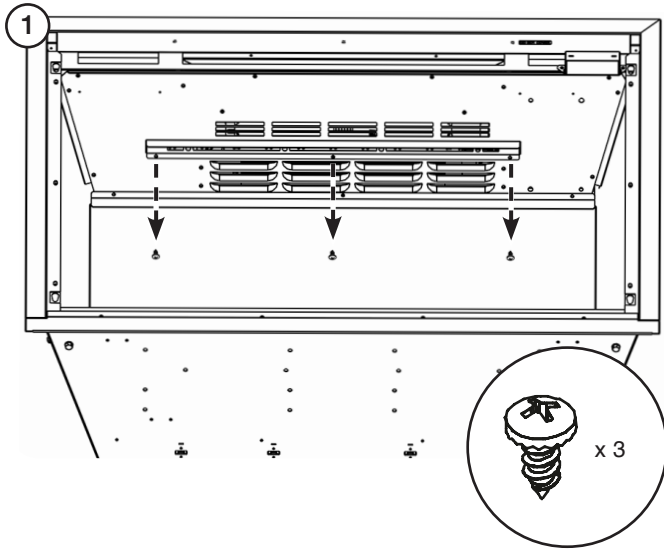

Carefully lower the LED Light Bar and disconnect the cable from the right hand side.

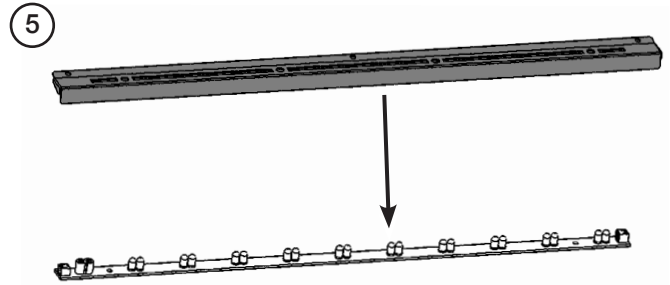
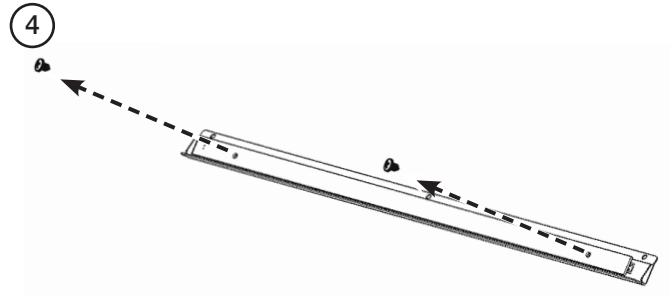
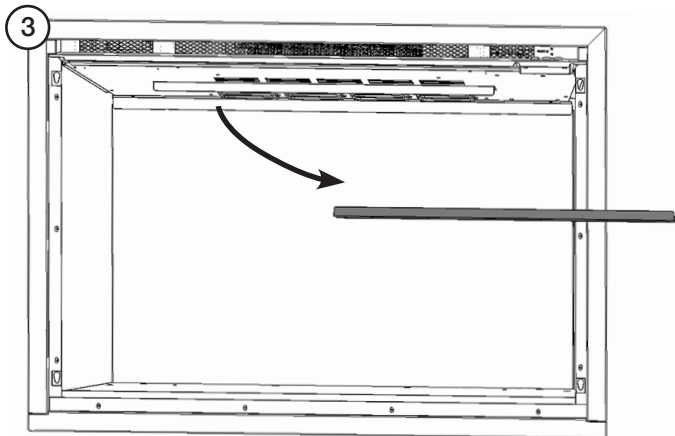
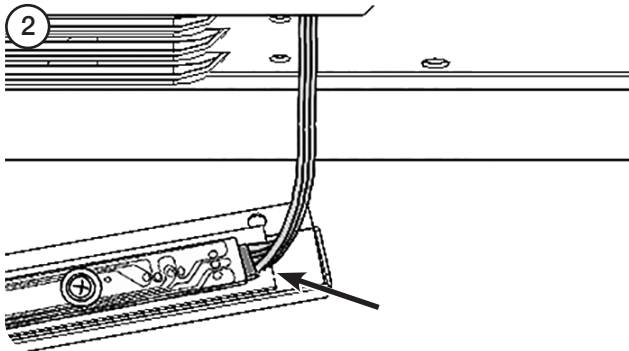

REMOVING THE BUTTON BOARD

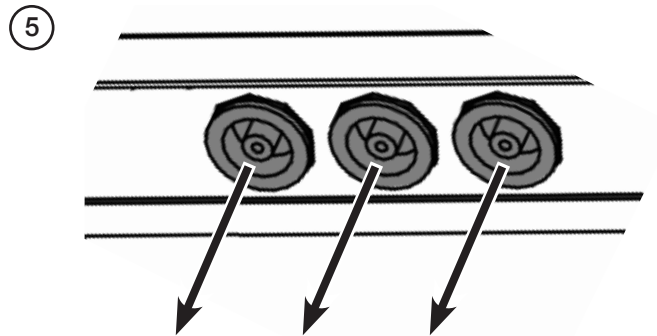
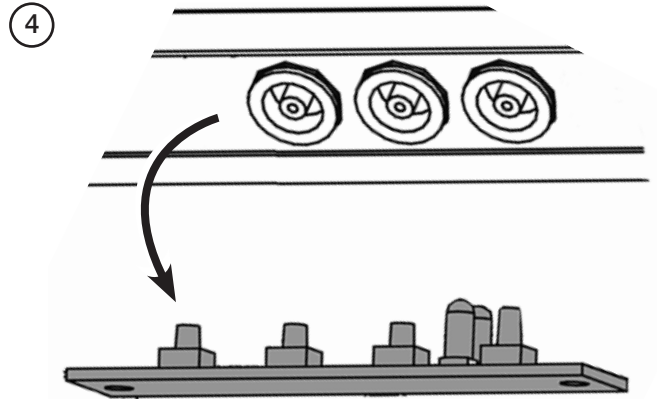
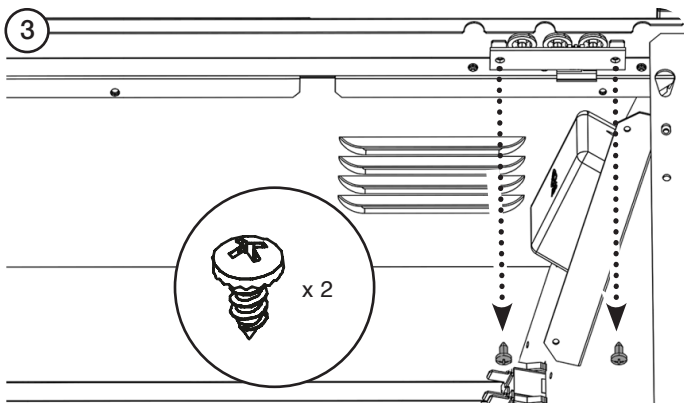
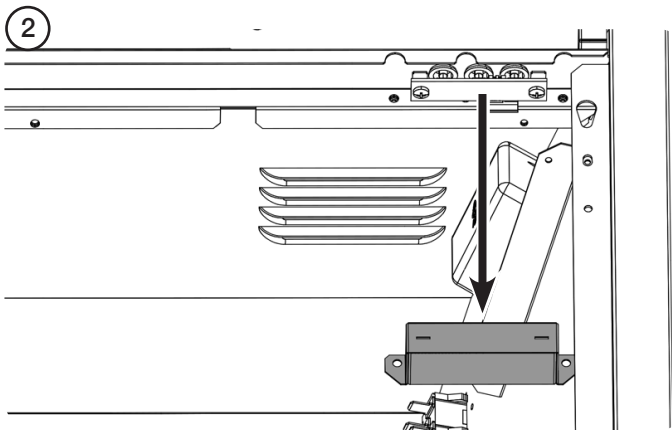
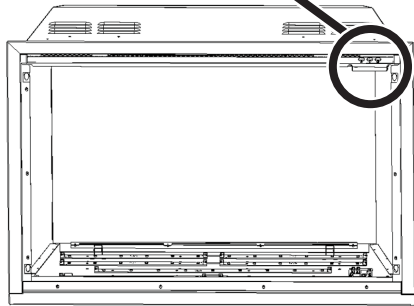
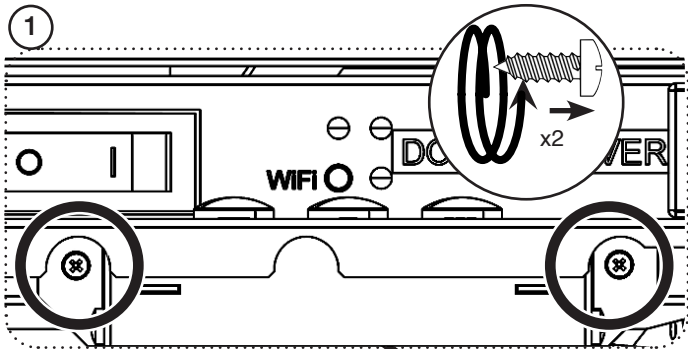

REMOVING THE INNER SCREEN

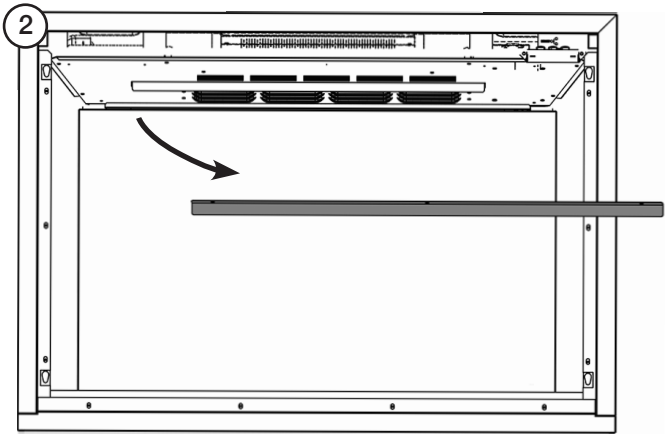
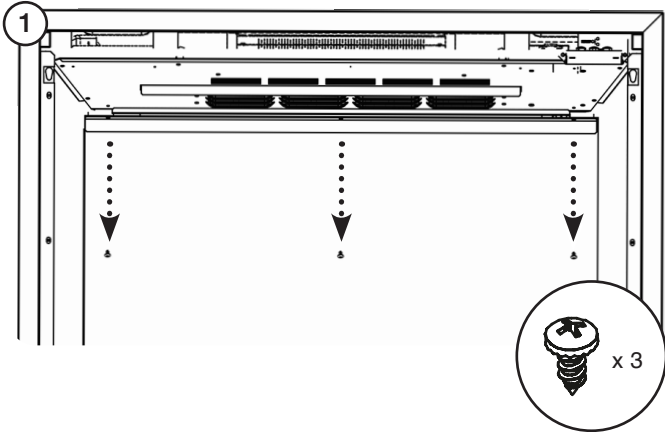

INNER SCREEN

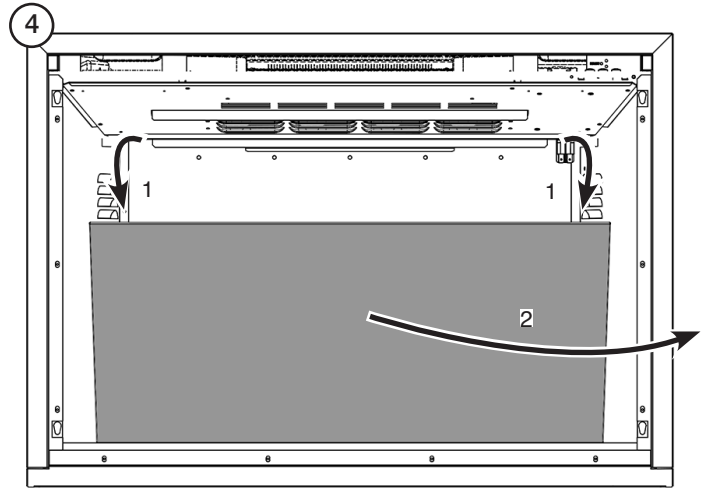

REAR GLASS

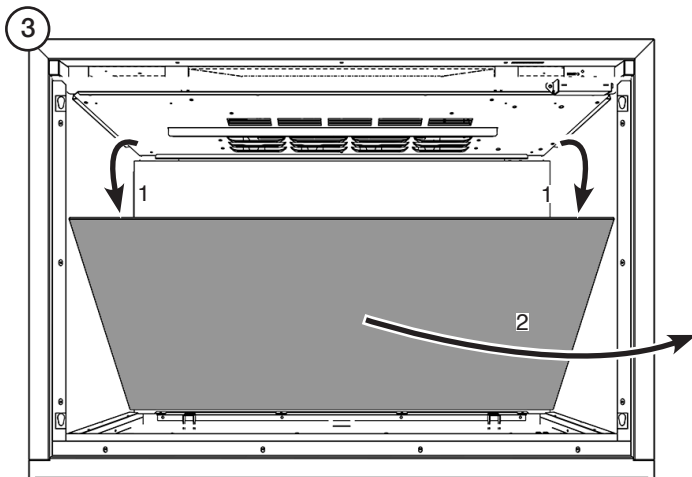

REMOVING THE FLAME EFFECT

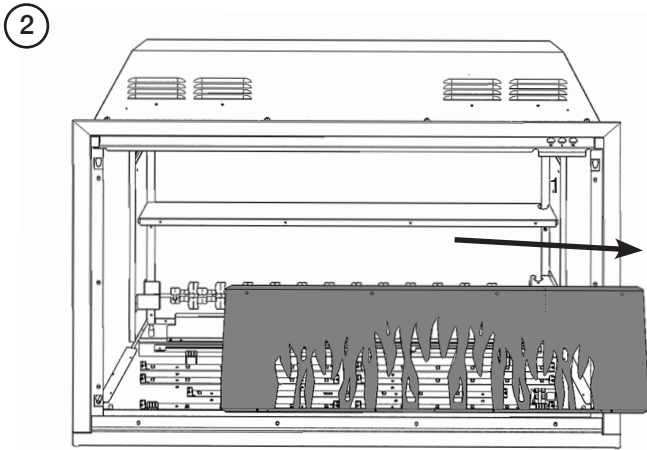
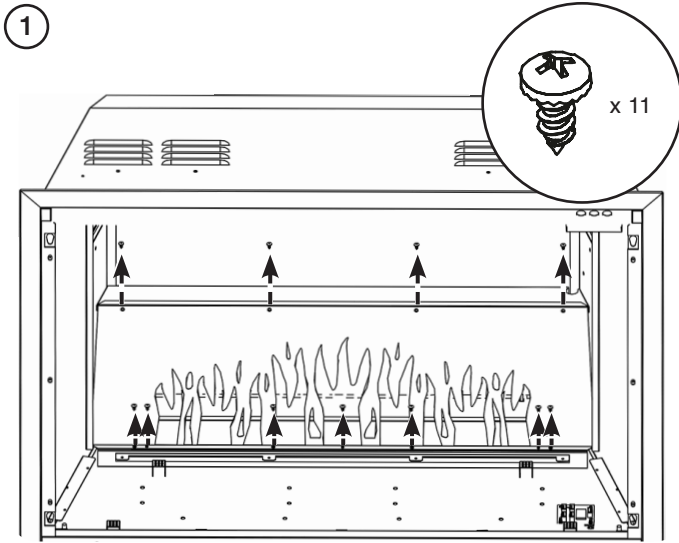

REMOVING THE EFFECT SPINDLE

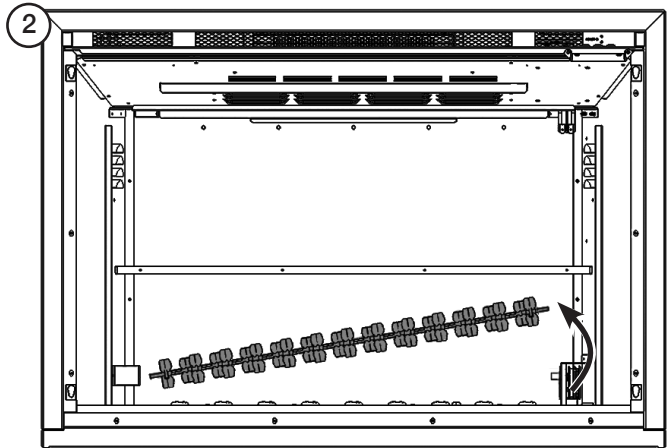
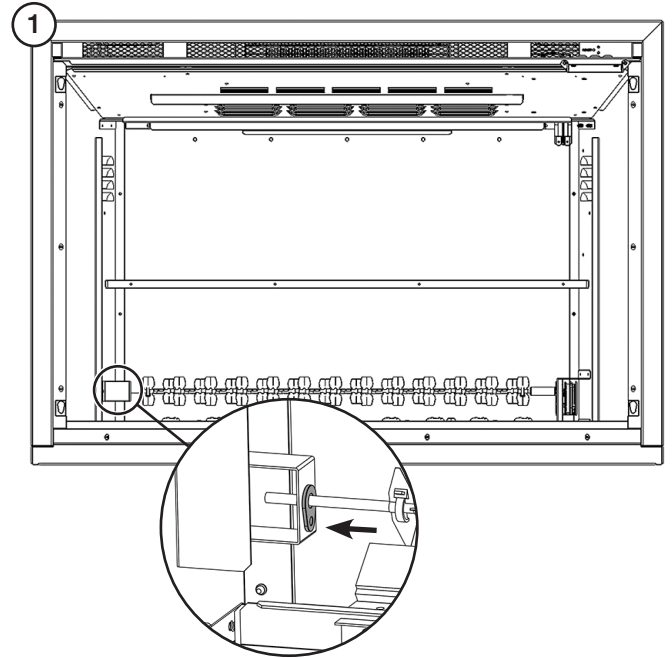

REPLACING THE FLAME EFFECT LEDs

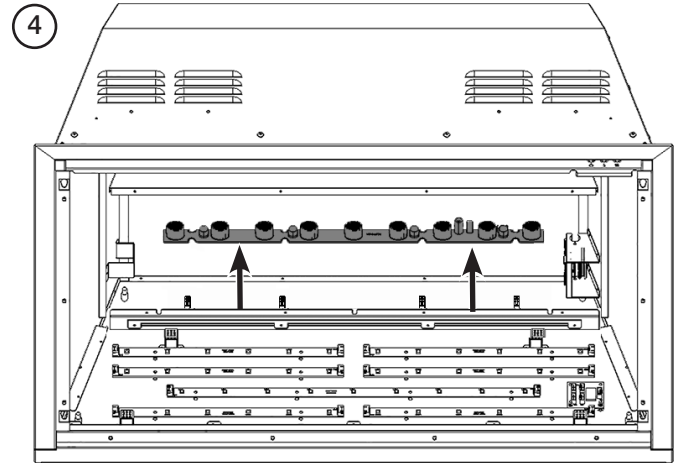
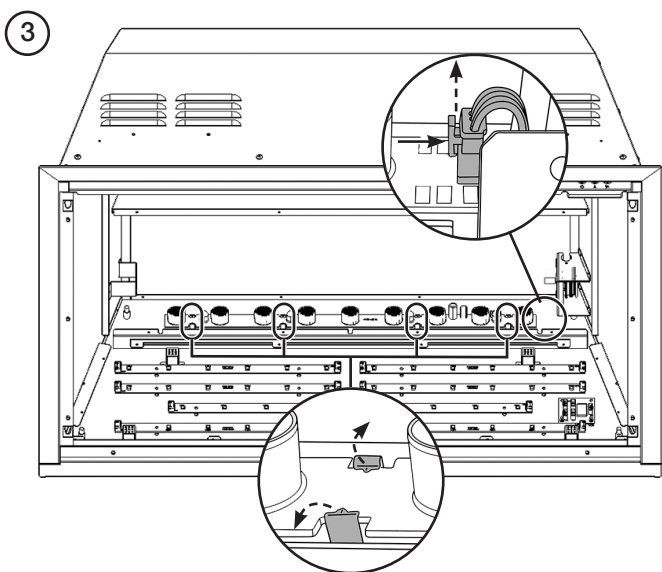
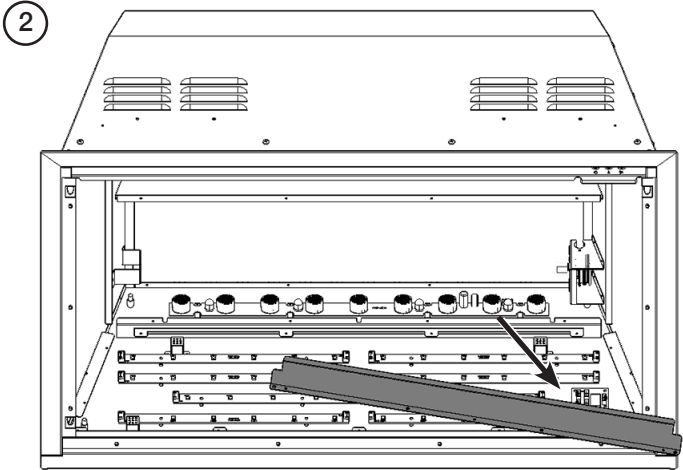
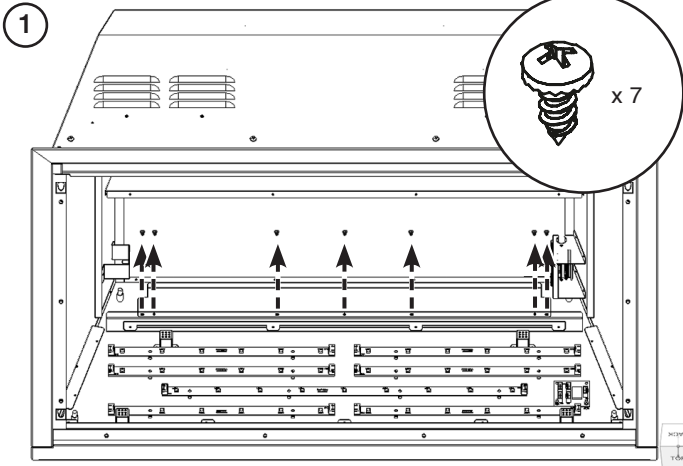

REMOVING THE EFFECT MOTOR

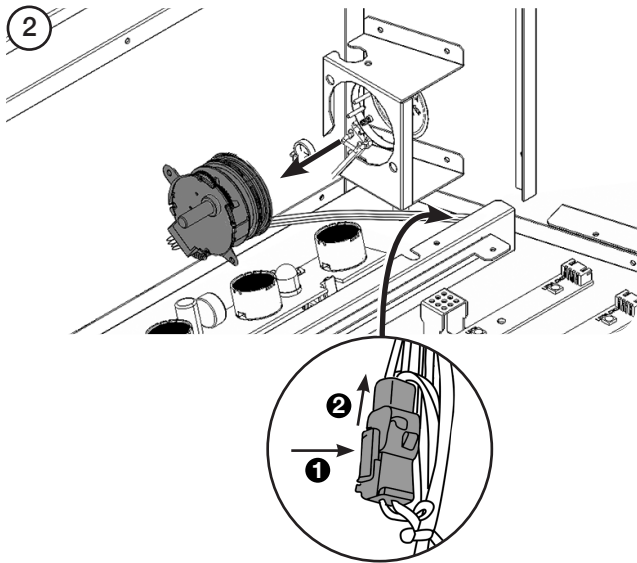
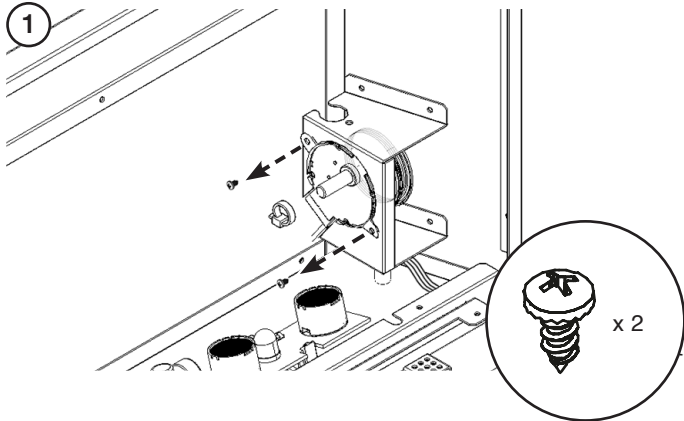

REMOVING TOP Baffle

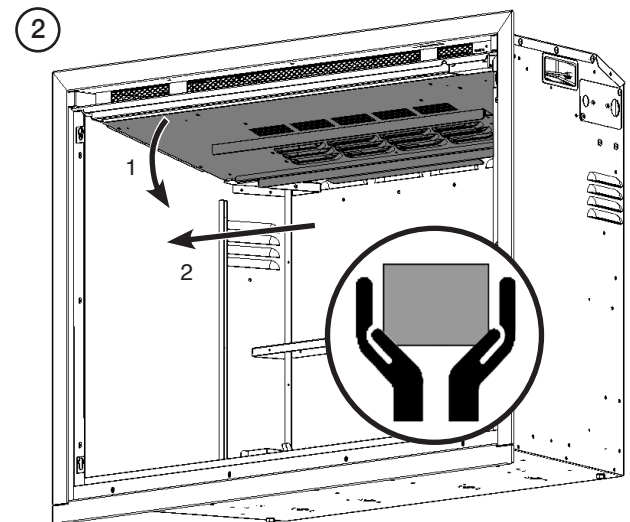
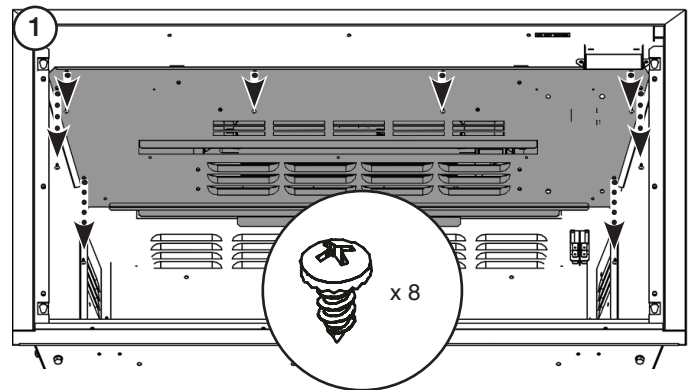
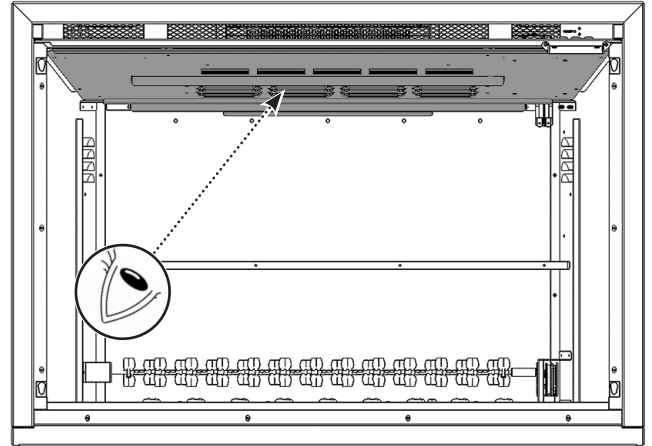

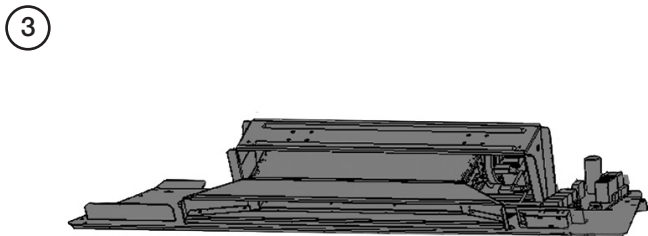
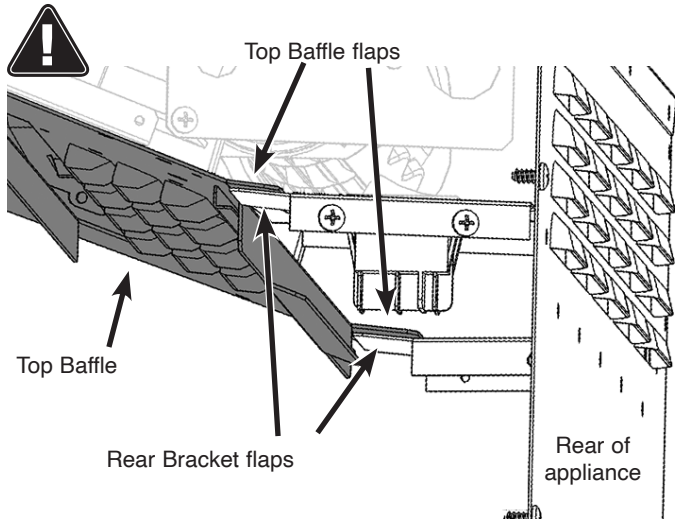

REMOVING THE PCB

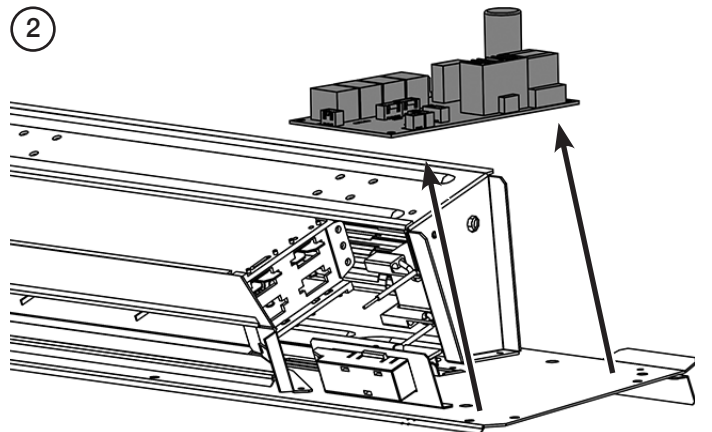
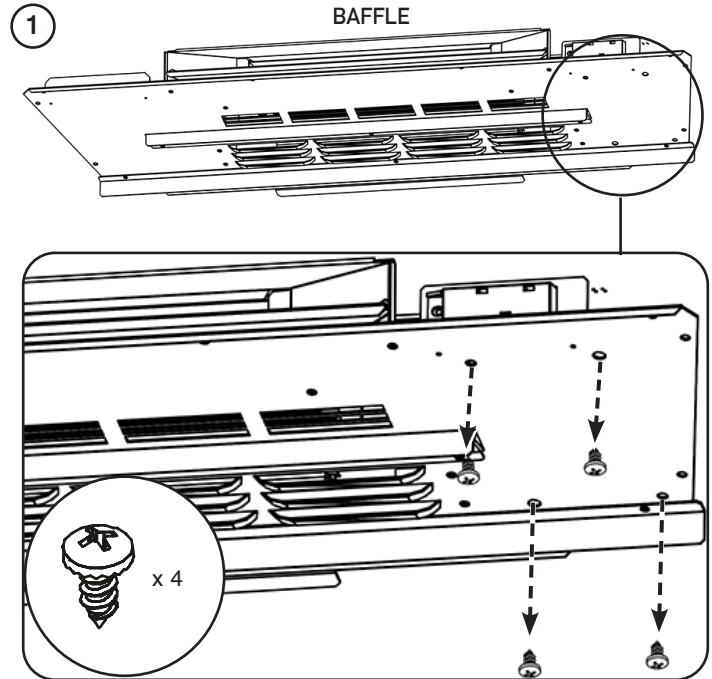

REMOVING THE RECEIVER

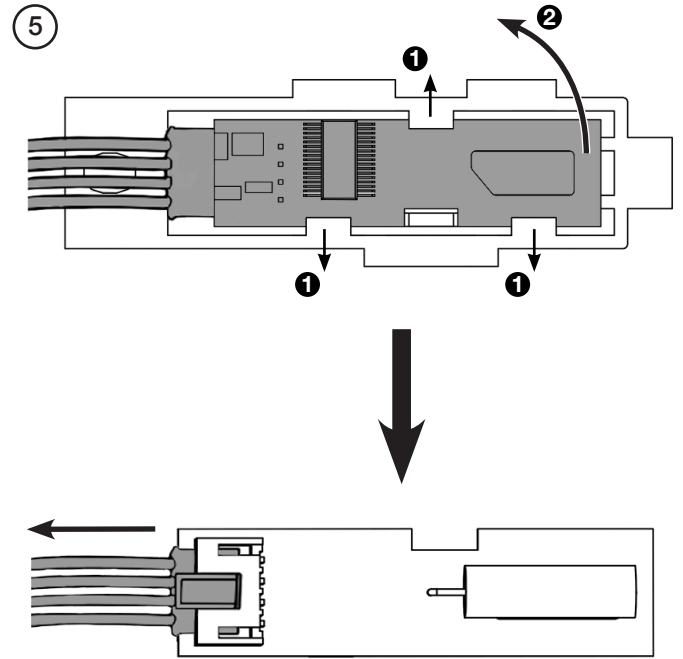
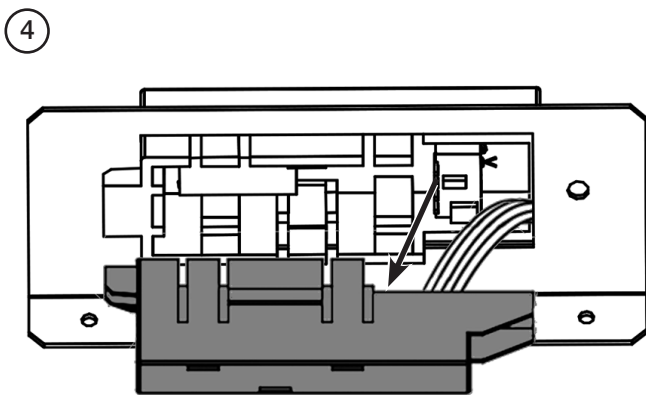
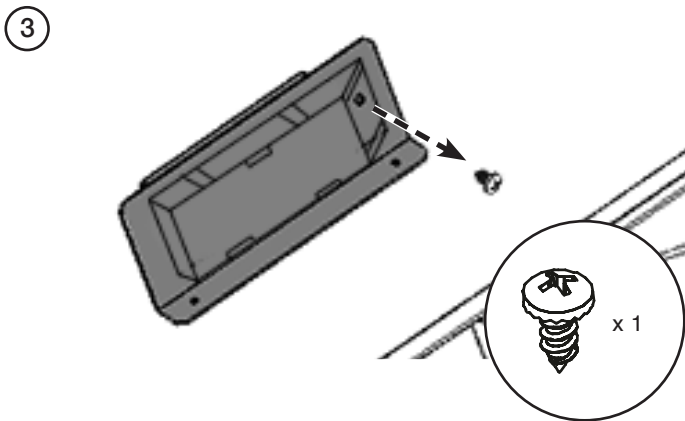
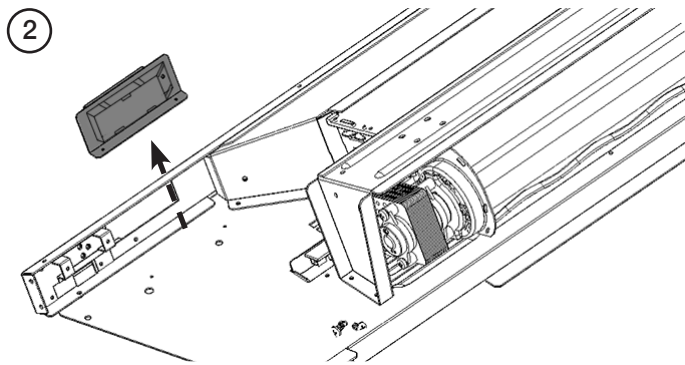
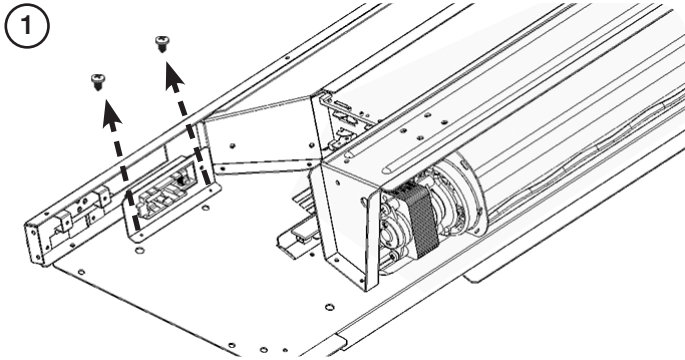

REPLACING THE HEATER

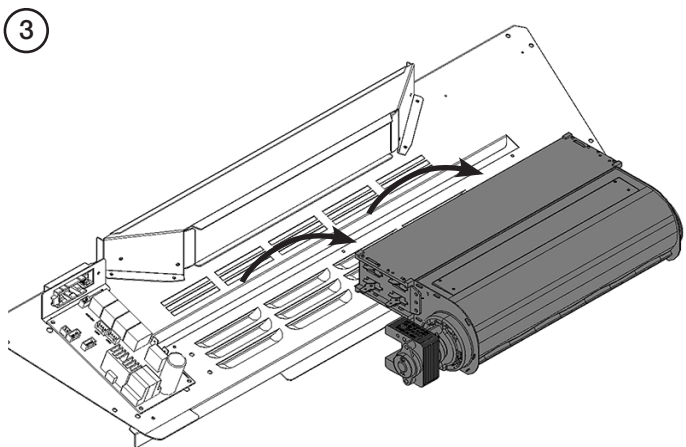
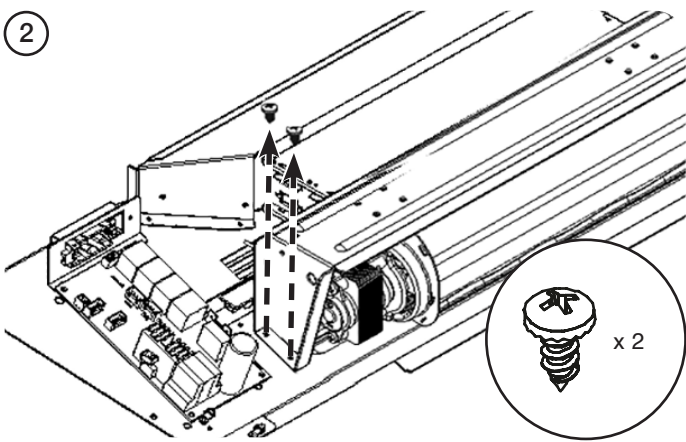
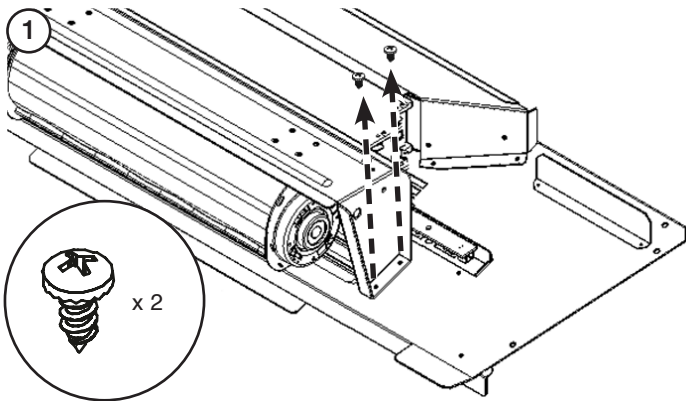

WIRING DIAGRAM

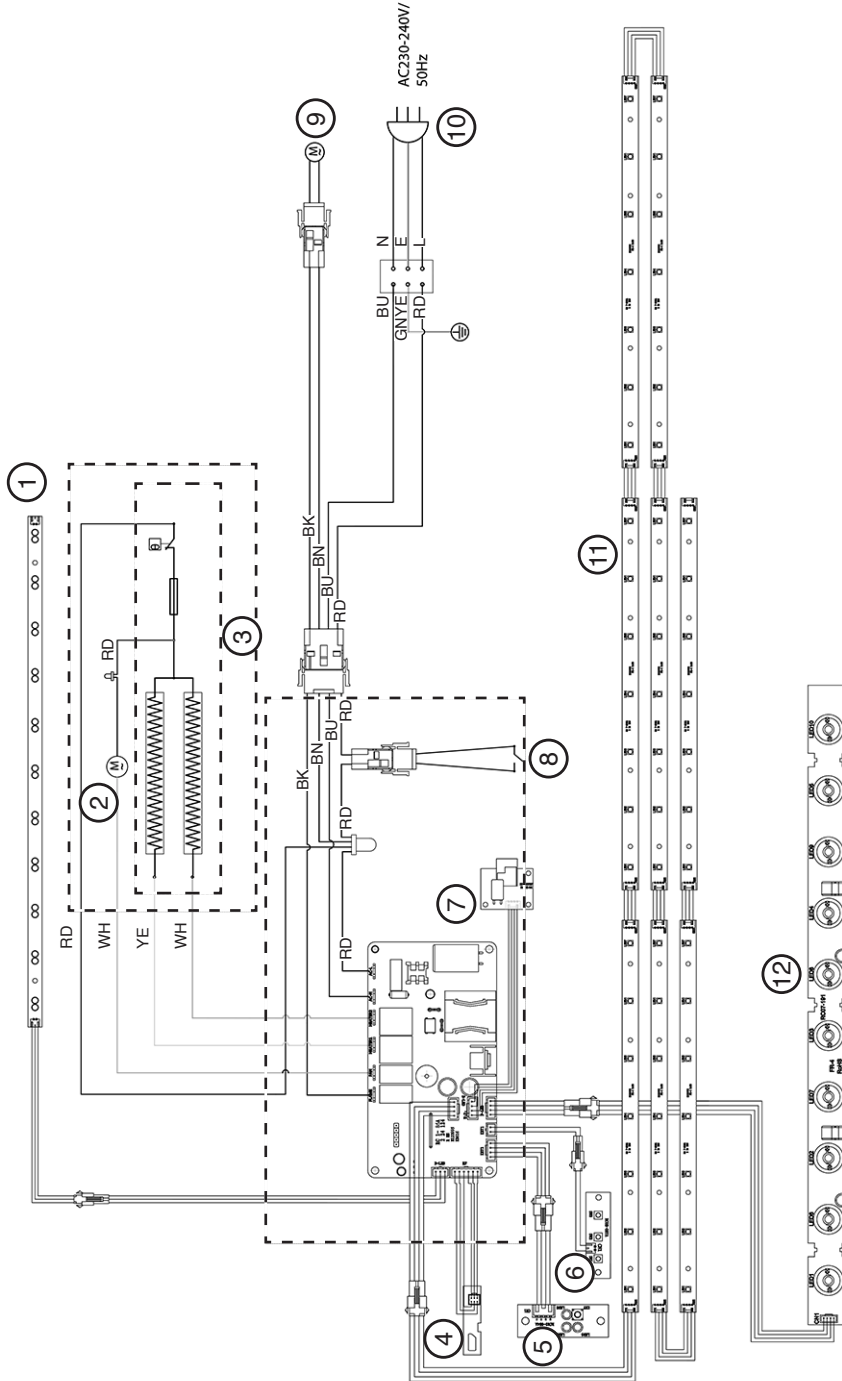

NO.	
1	LED Board RC07-283A
2	Fan Motor
3	Heater
4	Receiver Board
5	WiFi Board RC02-084A
6	Button Board RC02-041A
7	WiFi Receiver Board RC05-015A
8	Switch AC250V 16A
9	Flame Motor
10	Power Cable
11	LED Board RC07-288A (Total 8 pcs)
12	LED board RC07-191D (Total 1 pcs)

COLOUR CODES	
RD	RED
BU	BLUE
YE	YELLOW
WH	WHITE
BK	BLACK
BN	BROWN
GNYE	GREEN & YELLOW

SPARE PARTS

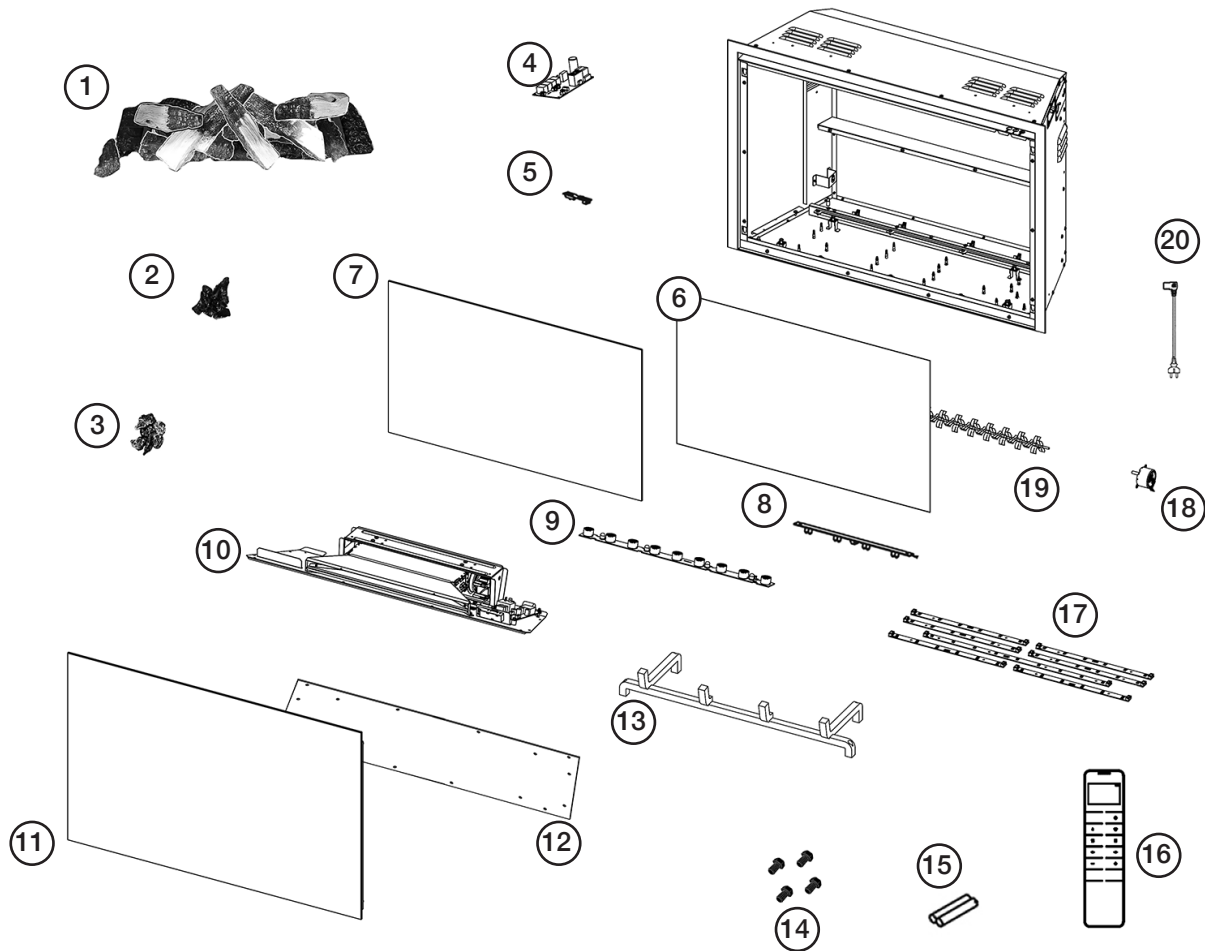

No.	Ei25		
	PART	PART CODE	QTY
1	Log Set	CE2233	1
2	Glass Embers	CE2235	1
3	Amber Crystals	CE2234	1
4	PCB	EL1154	1
5	Receiver	EL1153	1
6	Inner Screen	PL0276	1
7	Rear Glass	CE2237	1
8	Downlight	EL1155	1
9	Flame Effect LED Board	EL1160	1
10	Heater Assembly	EL1157	1
11	Front Glass	CE2236	1
12	Fuel Bed	PL0277	1
13	Grate	PL0279	1
14	Leveling Bolts (Set)	FA0870	1

No.	Ei25		
	PART	PART CODE	QTY
15	AAA Battery	EL0062	1
16	Remote	EL1163	1
17	RC07-288A	Fuelbed LEDs	N/A
	RC07-289A		N/A
	RC07-290A		EL1061
18	Flame Motor	EL0632	1
19	Flame Spindle	EL1109	1
20	Power Cable	EL0549	1

INFORMATION REQUIREMENT FOR ELECTRIC LOCAL SPACE HEATERS

Model		Ei25	
Heat Output	Nominal Heat Output	P_{nom}	2.0kW
	Minimum Heat Output	P_{min}	1.0kW
	Maximum Continuous Heat Output	$P_{max, c}$	2.0kW

Auxiliary Electricity Consumption	At Nominal Heat Output	el_{max}	10.0W
	At Minimum Heat Output	el_{min}	9.5W
	In Standby Mode	el_{sb}	0.84W

Type of heat input, for electric storage local space heaters only

Manual heat charge control, with integrated thermostat	No
Manual heat charge control with room and/or outdoor temperature feedback	No
Electronic heat charge control with room and/or outdoor temperature feedback	No
Fan assisted heat output	No

TYPE OF HEAT OUTPUT/ROOM TEMPERATURE CONTROL

Single stage heat output and no room temperature control	No
Two or more manual stages, no room temperature control	No
With mechanic thermostat room temperature control	No
With electronic room temperature control	Yes
Electronic room temperature control plus day timer	Yes
Electronic room temperature control plus week timer	Yes

OTHER CONTROL OPTIONS

Room temperature control, with presence detection	No
Room temperature control, with open window detection	Yes
With distance control option	Yes
With adaptive start control	Yes
With working time limitation	No
With black bulb sensor	No

WARRANTY

LIMITED WARRANTY

This product comes with an extended Limited Warranty to the original purchaser of this appliance provided the product remains in the original place of installation.

Some conditions apply (see below).

The policy is not transferable, amendable or negotiable under any circumstances.

After the original warranty coverage has expired, any repair and/or replacement parts purchased by the consumer through an accredited distributor or dealer will carry a ninety (90) day warranty (valid only with an original copy of the tax invoice). No labor coverage is included with any repair and/or replacement part.

Replacement parts are limited to one per warranty term.

Conditions:

Warranty protects against defect in manufacture or factory assembled components only, unless herein specified otherwise. This warranty will only apply to those products which are acquired at the time of this warranty being effective. Excluding liability for any damage or loss that falls outside the scope of the warranty.

Any part(s) found to be defective during the warranty period as outlined above will be repaired or replaced at the discretion of our accredited distributor, dealer or pre-approved and assigned agent provided that the defective part is returned to the distributor, dealer or agent for inspection if requested. Alternatively, the supplier may at its own discretion fully discharge all of its obligations under the warranty by refunding the verified purchase price of the product to the original purchaser. The purchase price must be confirmed by an original copy of the tax invoice.

The authorised selling dealer, or an alternative authorised dealer if pre-approved by the supplier, is responsible for all in-field diagnosis and service work related to all warranty claims. This warranty does not cover dealer travel costs for diagnostic or service work. Dealers may charge homeowner for travel and additional time. Check with your selling dealer in advance for any costs to you when arranging a warranty call. The supplier is not responsible for results or costs of workmanship of unauthorised dealers or agents in the negligence of their service work. Additional service fees may apply if you are seeking warranty service from a dealer other than the dealer from whom you originally purchased the product.

At all times the supplier reserves the right to inspect reported complaints on location in the field claimed to be defective and determine whether the warranty will apply prior to processing or authorising of any claim. Failure to allow this upon request will void the warranty.

All warranty claims must be submitted by the dealer servicing the claim, including an original copy of the tax invoice (proof of purchase by you). All claims must be complete and provide full details as requested to receive consideration for evaluation, including proof of maintenance records. Incomplete claims may be rejected. The supplier has absolute discretion to assess and determine any warranty claim and may accept or reject a claim as it considers appropriate. Any part or parts of the unit found to be defective will be repaired or replaced at the option of the supplier, through an accredited distributor or service agent provided that the defective part be returned to the distributor or agent, Transportation Prepaid, if requested. It is the general practice to charge for larger, higher priced replacement parts and issue credit once the replaced component has been returned and evaluated for manufacturer defect.

If a consumer has a unit installed outside an accredited distributor, dealer or pre-approved service agent's service area, or the closest approved service agent is situated more than thirty (30) kilometres from the installation, the supplier is not obliged to arrange warranty repairs or shipping/transportation costs. In these cases, the consumer must arrange warranty service with its selling dealer, and shipping, travel and/or additional labour charges will apply.

Unit must be installed according to all manufacturers' instructions as per the manual.

All Local and National required codes must be met.

The installer is responsible to ensure the unit is operating as designed at the time of installation.

The original purchaser is responsible for annual maintenance of the unit, as outlined in the owner's manual. As outlined below, the warranty may be voided due to problems caused by lack of maintenance. Annual maintenance records should be retained.

WARRANTY

EXCLUSIONS

This Limited Warranty does not extend to paint, rust or corrosion of any kind due to a lack of maintenance or improper venting, combustion air provision, corrosive chemicals (i.e. chlorine, salt, air, etc.), firebrick (rear, sides or bottom), door or glass gasket, or any other additional factory fitted gasket.

Malfunction, damage or performance based issues as a result of environmental conditions, location, chemical damages, downdrafts, installation error, installation by an unqualified installer, incorrect chimney components (including but not limited to cap size or type), operator error, abuse, misuse, use of improper fuels (such as unseasoned timber, mill-ends, construction timber or debris, off-cuts, treated or painted timber, tea tree, metal or foil, plastics, garbage, solvents, cardboard, coal or coal products, oil based products, waxed cartons, compressed pre-manufactured logs), accidents, lack of regular maintenance and upkeep, acts of God, weather related problems from hurricanes, tornados, earthquakes, floods, lightning strikes/bolts or acts of terrorism or war, which result in malfunction of the appliance are not covered under the terms of this Limited Warranty.

The supplier has no obligation to enhance or modify any unit once manufactured (i.e. as products evolve, field modifications or upgrades will not be performed on existing appliances).

Any unit showing signs of neglect or misuse will not be covered under the terms of this warranty policy and may void this warranty. This includes units with rusted or corroded fireboxes which have not been reported as rusted or corroded within three (3) months of installation/purchase. Any alteration to the unit which causes sooting or carboning that results in damage to the exterior fascia or over firing that can cause component or firebox/heat exchanger failure will not be covered by this warranty.

Units which show evidence of being operated while damaged, or with problems known to the purchaser and causing further damages will void this warranty.

Units where the serial no. has been altered, deleted, removed or made illegible will void this warranty.

Minor movement, expansion and contraction of the steel is normal and is not covered under the terms of this warranty.

Freight damages for products or parts are not covered under the terms of the warranty.

Porcelain/Enamel: Absolute perfection is neither guaranteed nor commercially possible. Any chips must be reported and inspected by the authorised selling dealer within three (3) days of installation. Any damage of this type not reported after this time period will be subject to rejection and any related warranty will not apply.

Special Finishes: Expect some changes in color as the product "ages" with constant heating and cooling. The manufacturer warranty does not cover tarnishing, changing colors and/or marks (i.e. finger prints, etc.) after the purchase of the product. Damage from the use of abrasive cleaners is not covered by warranty.

Products made or provided by other manufacturers and used in conjunction with the appliance may void this warranty.

INCORRECT INSTALLATION IS NOT COVERED BY WARRANTY. A SERVICE OR CALLOUT FEE WILL BE CHARGED IN THESE CIRCUMSTANCES.

WARRANTY

LIMITATIONS OF LIABILITY

1. Exclusion of implied terms

The customer may have the benefit of consumer guarantees under the Consumer Law. To the maximum extent permitted by law, all terms, conditions or warranties that would be implied into this Warranty or in connection with the supply of any goods or services by the supplier under law or statute or custom or international conventions are excluded.

2. Limitation of liability

(a) To the maximum extent permitted by law and subject to clause 1, the supplier's total liability arising out of or in connection with its performance or its obligations pursuant to this Warranty, or arising out of or in connection with the supply of specific goods or services (including pursuant to or for breach of this Warranty, under statute, in equity or for tort, including negligent acts or omissions) is limited as follows: (i) the supplier shall have no liability to the customer for any Consequential Loss; (ii) without limiting the effect of clause 2(a)(i), the supplier's total aggregate liability for Loss, however arising, shall not exceed the GST exclusive aggregate price paid by the customer to the supplier for the specific goods or services that gave rise to the Loss in question.

(b) The limitations and exclusions in this sub-clause do not apply to the extent that any Loss is directly attributable to: (i) the personal injury or death caused by the supplier's default, breach of this Warranty or negligence; or (ii) fraud by the supplier.

(c) Each party must take reasonable steps to mitigate any Loss it suffers or incurs. .

3. Subject to Change

This Limited Warranty is given at the time of sale and purchase of the relevant fireplace product. The terms of this Limited Warranty may be amended from time to time in accordance with changes to business practices, consumer laws or other legal requirements. The rights and protections granted under the Limited Warranty are those in force in relation to a fireplace product at the time and in the place of sale of that product, and only those terms will be applicable in respect of that product.

4. Severability

Any term of this Limited Warranty that is invalid or unenforceable in any jurisdiction is to be read down for the purposes of that jurisdiction, if possible, so as to be valid and enforceable, and is otherwise capable of being severed to the extent of the invalidity or unenforceability, without affecting the remaining provisions of this Limited Warranty or affecting the validity or enforceability of that provision in any other jurisdiction.

5. Definitions

For purposes of clauses 1 and 2:

(a) Consequential Loss means loss of expected savings, loss of use, loss of opportunity, loss of profit, loss of revenue, increased financing costs, loss arising from delay, or any consequential, special or indirect loss or damage, whether or not the possibility or potential extent of the loss or damage was known or foreseeable, and whether arising from a claim under indemnity, contract, tort (including negligence), statute or otherwise.

(b) Loss means any expense, cost or damage of any kind and includes Consequential Loss and a fine or penalty imposed by a statutory or other authority.

Fireplace Products Australia Pty Ltd
99 Colemans Road
Dandenong South VIC, 3175
AUSTRALIA
+613 9799 7277
www.regency-fire.com.au

Installer: Please complete the following information

Dealer Name & Address: _____

Installer: _____

Phone #: _____

Date Installed: _____

Serial #: _____

