



# HAMPTON®

www.hampton-fire.com

## H35 Direct Vent Gas Fireplace

## Owners & Installation Manual



MODELS: H35-NG1 Natural Gas H35-LP1 Propane

### WARNING:

If the information in these instructions are not followed exactly, a fire or explosion may result causing property damage, personal injury or loss of life.

### FOR YOUR SAFETY

Do not store or use gasoline or other flammable vapors and liquids in the vicinity of this or any other appliance.

Installation and service must be performed by a qualified installer, service agency or the gas supplier.

### FOR YOUR SAFETY

What to do if you smell gas:

- Do not try to light any appliance
- Do not touch any electrical switch: do not use any phone in your building.
- Immediately call your gas supplier from a neighbour's phone. Follow the gas supplier's instructions.
- If you cannot reach your gas supplier, call the fire department.

Tested by:



**Installer:** Please complete the details on the back cover and leave this manual with the homeowner.

**Homeowner:** Please keep these instructions for future reference.

# HAMPTON®

## Direct Vent Freestanding Gas Stove

To the New Owner:

Congratulations!

You are the owner of a state-of-the-art Hampton® Gas Stove by FPI FIREPLACE PRODUCTS INTERNATIONAL LTD. The H35 is a hand crafted appliance and has been designed to provide you with all the warmth and charm of a wood fireplace at the flick of a switch. The model H35 has been approved by Warnock Hersey for both safety and efficiency. As it also bears our own mark, it promises to provide you with economy, comfort and security for many trouble free years to follow. Please take a moment now to acquaint yourself with these instructions and the many features of your Hampton® Stove.

### UNIT DIMENSIONS

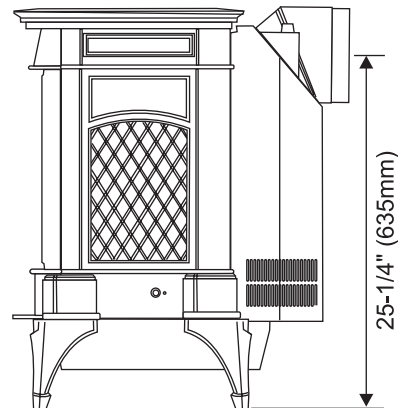
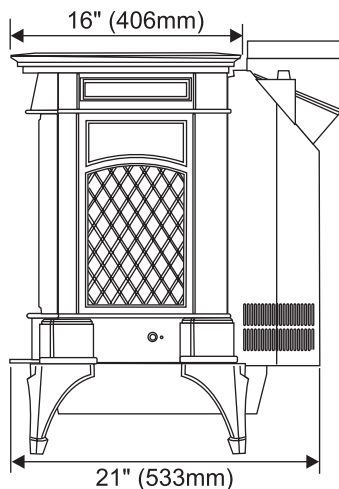
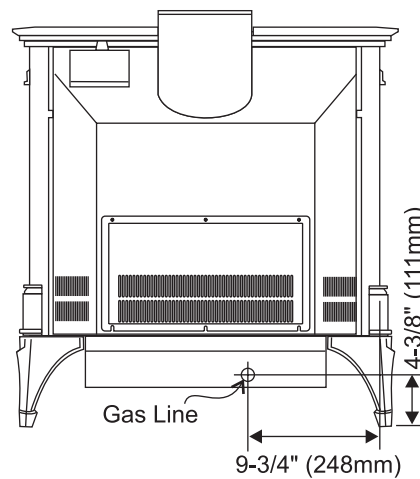
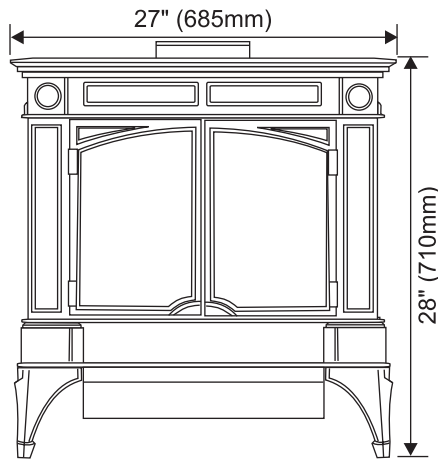

**NATIONAL FIREPLACE INSTITUTE**  
**NFI**  
**CERTIFIED**  
[www.nficertified.org](http://www.nficertified.org)

We recommend that our products be installed and serviced by professionals who are certified in the U.S. by the National Fireplace Institute® (NFI) or in Canada by Wood Energy Technical Training (WETT).

**Wood Energy Technical Training**  
[www.wettinc.ca](http://www.wettinc.ca)

**ONE REGENCY = ONE TREE**

For each Regency sold we plant a tree  
[AmericanForests.org](http://AmericanForests.org)

# TABLE OF CONTENTS

<b>SAFETY LABEL</b>	
Copy of Safety Label .....	4
<b>REQUIREMENTS</b>	
MA Code - CO Detector .....	5
<b>INSTALLATION</b>	
Specifications .....	6
Information for Mobile / Manufactured Homes After First Sale .....	6
General Safety Information .....	7
Installation Checklist.....	7
Clearances to Combustibles .....	7
Locating Your Gas Stove.....	8
Manufactured Mobile Home Additional Requirements ..	8
Combustion and Ventilation Air .....	8
Optional Fan Installation.....	8
Venting Introduction.....	9
Installation Precautions .....	9
Safety Precautions for The Installer .....	9
Vent Restrictor Position .....	9
Exterior Vent Terminal Locations .....	10
4" x 6-5/8" Rigid Pipe Cross Reference Chart .....	11
Rigid Pipe Venting Systems .....	13
Rotating 45° Elbow for Straight .....	14
Horizontal Terminations .....	14
Venting Arrangements .....	14
Vertical Termination With Co-linear Flex System.....	18
DV Stove Horizontal Vent Kit.....	19
Dura-Vent Termination Kit.....	21
Dura-Vent Horizontal Installations .....	22
Dura-Vent Vertical Termination .....	23
Converting Class-A Metal Chimney or .....	25
Masonry Chimney to Direct Vent System.....	25
Cathedral Ceilings .....	26
High Elevation .....	26
Gas Connection.....	26
Aeration Adjustment .....	27
Gas Pipe Pressure Testing.....	27
Conversion Kit #791-969 from NG to LP.....	28
Conversion Kit to Lower BTU Rating.....	32
Optional Brick Panel.....	33
Log Set Installation.....	33
Double Door Installation .....	35
Decorative Door Grill Installation .....	35
Tile Inset Installation.....	35
Door Hinge Removal .....	36
Wiring Diagrams .....	37
Wall Thermostat .....	38
Remote Control .....	38
Final Check .....	39
<b>OPERATING INSTRUCTIONS</b>	
Operating Instructions .....	39
Lighting Procedure .....	39
Shutdown Procedure.....	39
First Fire .....	39
Copy of the Lighting Plate Instructions .....	40
Adjusting Flame Height .....	40
Automatic Convection Fan Operation .....	40
<b>MAINTENANCE</b>	
Normal Operating Sounds of Gas Appliances.....	41
Maintenance Instructions .....	41
Fan Maintenance.....	42
General Vent .....	42
Maintenance .....	42
Log Replacement .....	42
Glass Replacement .....	42
Removing Valve.....	43
Installing Valve Assembly .....	43
Main Assembly .....	44
Burner & Log Assembly .....	45
<b>WARRANTY</b>	
Burner & Log Assembly.....	47

# SAFETY LABEL

This is a copy of the label that accompanies each Direct Vent Freestanding Gas Stove. We have printed a copy of the contents here for your review.

NOTE: Hampton® units are constantly being improved. Check the label on the unit and if there is a difference, the label on the unit is the correct one.

## COPY OF SAFETY LABEL



**Listed:** GAS FIRED VENTED ROOM HEATER  
**Certified for/Certifiée pour:**  
CANADA and U.S.A.



**DO NOT REMOVE THIS LABEL /  
NE PAS ENLEVER CETTE ÉTIQUETTE**

303

**Report No.** 476-1986-00 (Oct. 2001)  
**Tested to:** CGA 2-17-M91, ANSIZ21.88b-2003/CSA 2.33b-2003  
MAY BE INSTALLED IN MANUFACTURED (MOBILE) HOMES AFTER FIRST SALE

Serial No./ No de serie

---

**FACTORY EQUIPPED FOR NATURAL GAS Model:H35-NG1 ÉQUIPÉ À L'UISINE POUR GAZ NATURAL**

○ Model/Modèle: H35-NG1	Minimum supply pressure	5" WC/C.E. (1.25 kPa)	Pression d'alimentation minimum
	Manifold pressure High	3.8" WC/C.E. (0.94 kPa)	Pression à la tubulure d'échappement élevée
	Manifold pressure Low	1.1" WC/C.E. (0.27 kPa)	Pression à la tubulure d'échappement basse
	Maximum Input	36,000 Btu/h (10.55 Kw/h)	Débit Calorifique maximum
	Minimum Input	18,000 Btu/h (5.28 Kw/h)	Débit Calorifique minimum
	Orifice size	#33 DMS (2.87mm)	Dimensions de l'orifice
	Altitude	0-4500 ft/pi (0-1372m)	L'altitude

**Convertible to 30,000**

Orifice Size	#37 DMS	Dimensions de l'orifice
Maximum Input	30,000 Btu/h (8.78 Kw/h)	Débit Calorifique maximum selon
Minimum Input	14,300 Btu/h (4.19 Kw/h)	Débit Calorifique minimum selon
Altitude	0-4500 ft/pi (0-1372m)	L'altitude

---

**FACTORY EQUIPPED FOR PROPANE GAS Model:H35-LP1 ÉQUIPÉ À L'UISINE POUR GAZ PROPANE**

○ Model/Modèle: H35-LP1	Minimum supply pressure	12" WC/C.E. (3.00 kPa)	Pression d'alimentation minimum
	Manifold pressure High	11" WC/C.E. (2.74 kPa)	Pression à la tubulure d'échappement élevée
	Manifold pressure Low	2.9" WC/C.E. (0.72 kPa)	Pression à la tubulure d'échappement basse
	Maximum Input	34,000 Btu/h (9.97 Kw/h)	Débit Calorifique maximum
	Minimum Input	17,500 Btu/h (5.13 Kw/h)	Débit Calorifique minimum
	Orifice size	#51 DMS (1.70mm)	Dimensions de l'orifice
	Altitude	0-4500 ft/pi (0-1372m)	L'altitude

**Convertible to 28,500 Btu**

Orifice Size	#52 DMS	Dimensions de l'orifice
Maximum Input	28,500 Btu/h (8.35 Kw/h)	Débit Calorifique maximum selon
Minimum Input	15,000 Btu/h (4.39 Kw/h)	Débit Calorifique minimum selon
Altitude	0-4500 ft/pi (0-1372m)	L'altitude

---

**Minimum Clearances to Combustibles/Degagement Minimum De Materiaux Combustibles**

Minimum ceiling height from top of unit: 36"/914mm  
Minimum plafond hauteur en haut de l'appareil: 36"/914mm

<b>A</b> 6-1/2"/165mm	<b>C</b> 2" / 50mm
<b>B</b> 6"/152mm	<b>E</b> 2"/50mm

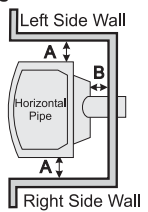

Horizontal Pipe

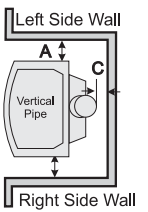

Vertical Pipe

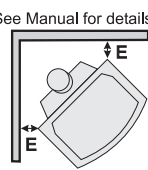

See Manual for details

Minimum clearance of Vent Terminal to Outside Corner & Inside Corner:  
with AstroCap 6"/150mm  
with Dura-Vent Cap 12"/300mm

---

**GAS FIRED VENTED ROOM HEATER:** This appliance must be installed in accordance with local codes, if any; If not, follow: ANSI Z223.1/CAN/CGA-B149 Electrical Supply (115 V, 1.13A, 60 Hz). Not for use with solid fuels.

**POLE R GAS RADIATEUR VENTILE**  
Cet appareil doit être installé conformément aux exigences des codes locaux, s'il n'existe aucun code local, se conformer à la norme: ANSI Z223.1/CAN/CGA-B149 en vigueur. Alimentation électrique. Ne doit pas être utilisé avec un combustible solide.

This appliance is only for use with the type of gas indicated on the rating plate and may be installed in an aftermarket, permanently located, manufactured (mobile) home where not prohibited by local codes. See owner's manual for details. This appliance is not convertible for use with other gases, unless a certified kit is used.

---

**FPI Fireplace Products International Ltd. Delta, BC, Canada**  
Made in Canada/Fabrique au Canada

918-496 

For the State of Massachusetts, installation and repair must be done by a plumber or gasfitter licensed in the Commonwealth of Massachusetts.

For the State of Massachusetts, flexible connectors shall not exceed 36 inches in length.

For the State of Massachusetts, the appliances individual manual shut-off must be a t-handle type valve.

The State of Massachusetts requires the installation of a carbon monoxide alarm in accordance with NFPA 720 and a CO alarm with battery back up in the same room where the gas appliance is installed.

## MA Code - CO Detector (for the State of Massachusetts only)

### 5.08: Modifications to NFPA-54, Chapter 10

(2) Revise 10.8.3 by adding the following additional requirements:

(a) For all side wall horizontally vented gas fueled equipment installed in every dwelling, building or structure used in whole or in part for residential purposes, including those owned or operated by the Commonwealth and where the side wall exhaust vent termination is less than seven (7) feet above finished grade in the area of the venting, including but not limited to decks and porches, the following requirements shall be satisfied:

1. **INSTALLATION OF CARBON MONOXIDE DETECTORS.** At the time of installation of the side wall horizontal vented gas fueled equipment, the installing plumber or gasfitter shall observe that a hard wired carbon monoxide detector with an alarm and battery back-up is installed on the floor level where the gas equipment is to be installed. In addition, the installing plumber or gasfitter shall observe that a battery operated or hard wired carbon monoxide detector with an alarm is installed on each additional level of the dwelling, building or structure served by the side wall horizontal vented gas fueled equipment. It shall be the responsibility of the property owner to secure the services of qualified licensed professionals for the installation of hard wired carbon monoxide detectors

a. In the event that the side wall horizontally vented gas fueled equipment is installed in a crawl space or an attic, the hard wired carbon monoxide detector with alarm and battery back-up may be installed on the next adjacent floor level.

b. In the event that the requirements of this subdivision can not be met at the time of completion of installation, the owner shall have a period of thirty (30) days to comply with the above requirements; provided, however, that during said thirty (30) day period, a battery operated carbon monoxide detector with an alarm shall be installed.

2. **APPROVED CARBON MONOXIDE DETECTORS.** Each carbon monoxide detector as required in accordance with the above provisions shall comply with NFPA 720 and be ANSI/UL 2034 listed and IAS certified.

3. **SIGNAGE.** A metal or plastic identification plate shall be permanently mounted to the exterior of the building at a minimum height of eight (8) feet above grade directly in line with the exhaust vent terminal for the horizontally vented gas fueled heating appliance or equipment. The sign shall read, in print size no less than one-half (1/2) inch in size, "**GAS VENT DIRECTLY BELOW. KEEP CLEAR OF ALL OBSTRUCTIONS**".

4. **INSPECTION.** The state or local gas inspector of the side wall horizontally vented gas fueled equipment shall not approve the installation unless, upon inspection, the inspector observes carbon monoxide detectors and signage installed in accordance with the provisions of 248 CMR 5.08(2)(a)1 through 4.

(b) **EXEMPTIONS:** The following equipment is exempt from 248 CMR 5.08(2)(a)1 through 4:

1. The equipment listed in Chapter 10 entitled "Equipment Not Required To Be Vented" in the most current edition of NFPA 54 as adopted by the Board; and

2. Product Approved side wall horizontally vented gas fueled equipment installed in a room or structure separate from the dwelling, building or structure used in whole or in part for residential purposes.

(c) **MANUFACTURER REQUIREMENTS - GAS EQUIPMENT VENTING SYSTEM PROVIDED.** When the manufacturer of Product Approved side wall horizontally vented gas equipment provides a venting system design or venting system components with the equipment, the instructions provided by the manufacturer for installation of the equipment and the venting system shall include:

1. Detailed instructions for the installation of the venting system design or the venting system components; and

2. A complete parts list for the venting system design or venting system.

(d) **MANUFACTURER REQUIREMENTS - GAS EQUIPMENT VENTING SYSTEM NOT PROVIDED.** When the manufacturer of a Product Approved side wall horizontally vented gas fueled equipment does not provide the parts for venting the flue gases, but identifies "special venting systems", the following requirements shall be satisfied by the manufacturer:

1. The referenced "special venting system" instructions shall be included with the appliance or equipment installation instructions; and

2. The "special venting systems" shall be Product Approved by the Board, and the instructions for that system shall include a parts list and detailed installation instructions.

(e) A copy of all installation instructions for all Product Approved side wall horizontally vented gas fueled equipment, all venting instructions, all parts lists for venting instructions, and/or all venting design instructions shall remain with the appliance or equipment at the completion of the installation.

# INSTALLATION

## IMPORTANT MESSAGE SAVE THESE INSTRUCTIONS

The Direct Vent Freestanding Gas Stove must be installed in accordance with these instructions. Carefully read all the instructions in this manual first. Consult the building authority having jurisdiction to determine the need for a permit prior to starting the installation.

**Note:** Failure to follow the instructions could cause a malfunction of the heater which could result in death, serious bodily injury, and/or property damage. Failure to follow these instructions may also void your fire insurance and/or warranty.

**Note:** These instructions take precedence over Simpson Dura-Vent instructions.

## SPECIFICATIONS

**Fuels:** H35-NG1 is approved for use with natural gas.

H35-LP1 is approved for use with liquefied petroleum gases (propane).

**Electrical:** 120V A.C. system.

**Circulation Fan:** Variable speed, 125/75.

**Log Sets:** Ceramic fibre, 7 per set.

**Vent System:** Coaxial (6-5/8" outer / 4" inner liner) rigid flue and termination cap.

The efficiency rating of the appliance is a product thermal efficiency rating determined under continuous operating conditions and was determined independent of any installed system.

## INFORMATION FOR MOBILE / MANUFACTURED HOMES AFTER FIRST SALE

This Hampton® product has been tested and listed by ITS Testing Services as a Direct Vent Wall Furnace to the following standards: CGA-2.17-M91, and ANSI Z21.88b-2003/CSA 2.33b-2003.

This Direct Vent System Appliance must be installed in accordance with the manufacturer's installation instructions and the Manufactured

Home Construction and Safety Standard, Title 24 CFR, Part 3280, or the current Standard of Fire Safety Criteria for Manufactured Home Installations, Sites, and Communities ANSI/NFPA 501A, and with CAN/CSA Z240-MH Mobile Home Standard in Canada.

This appliance installation must comply with the manufacturer's installation instructions and local codes, if any. In the absence of local codes follow the current National Fuel Gas Code, ANSI Z223.1 and the current National Electrical Code ANSI/NFPA 70 in the U.S.A., and the current CAN/CGA B149 Gas Installation Code and the current Canadian Electrical Code CSA C22.1 in Canada.

This Hampton® Mobile/Manufactured Home Listed appliance comes factory equipped with a means to secure the unit.

This Hampton® Mobile/Manufactured Home listed appliance comes equipped with a dedicated #8 ground lug to which an 18 gauge copper wire from the steel chassis ground must be attached.

**This appliance may only be installed in an aftermarket permanently located, manufactured (USA only) or mobile home, where not prohibited by local codes.**

**This appliance is only for use with the type of gas indicated on the rating plate. This appliance is not convertible for use with other gases, unless a certified kit is used.**

## BEFORE YOU START

Safe installation and operation of this appliance requires common sense, however, we are required by the Canadian Safety Standards and ANSI Standards to make you aware of the following:

**INSTALLATION AND REPAIRS SHOULD BE DONE BY A QUALIFIED SERVICE PERSON. THIS APPLIANCE SHOULD BE INSTALLED, REPAIRED, INSPECTED BEFORE USE AND AT LEAST ANNUALLY BY A QUALIFIED SERVICE PERSON. MORE FREQUENT CLEANING MAY BE REQUIRED DUE TO EXCESSIVE LINT FROM CARPETING, ETC. IT IS IMPERATIVE THAT THE CONTROL COMPARTMENT, BURNERS AND CIRCULATING AIR PASSAGEWAYS OF THE APPLIANCE BE KEPT CLEAN.**

**DUE TO HIGH TEMPERATURES, THE APPLIANCE SHOULD BE LOCATED OUT OF TRAFFIC AND AWAY FROM FURNITURE AND DRAPERIES.**

**WARNING: FAILURE TO INSTALL THIS APPLIANCE CORRECTLY WILL VOID YOUR WARRANTY AND MAY CAUSE A SERIOUS HOUSE FIRE.**

**CHILDREN AND ADULTS SHOULD BE ALERTED TO THE HAZARDS OF HIGH SURFACE TEMPERATURES, ESPECIALLY THE FIREPLACE GLASS, AND SHOULD STAY AWAY TO AVOID BURNS OR CLOTHING IGNITION.**

**YOUNG CHILDREN SHOULD BE CAREFULLY SUPERVISED WHEN THEY ARE IN THE SAME ROOM AS THE APPLIANCE.**

**CLOTHING OR OTHER FLAMMABLE MATERIAL SHOULD NOT BE PLACED ON OR NEAR THE APPLIANCE.**

- 1) Provide adequate clearances for servicing, proper operation and around the air openings into the combustion chamber.
- 2) The appliance must be installed on a flat, solid, continuous surface (e.g. wood, metal, concrete). This may be the floor, or it can be raised up on a platform to enhance its visual impact. The appliance may be installed on carpeting, tile, wood flooring or other combustible material, because the appliance's base extends the full width and depth of the appliance. The Direct Vent Freestanding Gas Stove can be installed in a wide variety of ways and will fit nearly any room layout. It may be installed in a recessed position, framed out into the room, or across a corner.
- 3) The Direct Vent Freestanding Gas Stove is approved for alcove installations, which meet the clearances listed in the "Clearance to Combustibles" section. This unit is approved for manufactured home installations, see the "Manufactured Mobile Home Additional Requirements" section and the "Venting Arrangement" section for the required vent arrangements. If installed into a manufactured home the unit must be bolted down to the floor.
- 4) This appliance is Listed for bedroom installations when used with a Listed Millivolt Thermostat. Some areas may have further requirements, check local codes before installation.
- 5) This appliance is Listed for Alcove installations, maintain minimum Alcove clearances as follows, minimum width of 40" (1016mm), a maximum depth of 36" (914mm), and minimum ceiling height of 64" (1626mm) from floor to ceiling.
- 6) We recommend that you plan your installation on paper using exact measurements for clearances and floor protection before actually installing this appliance. Have a qualified building inspector review your plans before installation.

## GENERAL SAFETY INFORMATION

- 1) The appliance installation must conform with local Canadian Electrical Code.
- 2) The appliance when installed, must be electrically grounded in accordance with local codes, or in the absence of local codes with the current National Electrical Code, ANSI/NFPA 70 or CSA C22.1 Canadian Electrical Code.
- 3) The appliance should be inspected for shipping damage before use and **serviced annually by a professional service person**. More frequent cleaning may be required due to excessive lint from carpeting, bedding material, etc. It is imperative that control compartments, and circulating air passageways of the appliance be kept clean and free from excessive lint from carpeting.
- 4) See general construction and assembly instructions. The appliance and vent should be enclosed when installed in or passing through a living area, where children may come in contact with it.
- 5) This appliance must be connected to the specified vent and termination cap to the outside of the building envelope. Never vent to another room or inside a building. Make sure that the vent is fitted as per the instructions starting in the "Exterior Vent Terminal Locations" section.
- 6) Inspect the venting system annually for blockage and any signs of deterioration.
- 7) Venting terminals shall not be recessed into a wall or siding.
- 8) Any safety glass removed for servicing must be replaced prior to operating the appliance.
- 9) To prevent injury, do not allow anyone who is unfamiliar with the operation to use the fireplace.

Emissions from burning wood or gas could contain chemicals known to the State of California to cause cancer, birth defects or other reproductive harm.

## INSTALLATION CHECKLIST

- 1) Locate your appliance. Refer to the following sections:
  - a. Clearances to combustibles
  - b. Locating Your Gas Stove
  - c. For venting requirements, see "Venting

Introduction" to "Venting Arrangements" sections.

- 2) Install Optional Fan. Refer to the "Optional Fan Installation" section.
- 3) Set vent restrictors. Refer to the "Vent Restrictor Position" section.
- 4) Install venting. Refer to the following sections where applicable:
  - a. Check all venting requirements. See "Venting Introduction" to "Venting Arrangements" sections.
  - b. Vertical Termination with Co-linear Flex System
  - c. DV Stove Horizontal Vent Kit
  - d. Dura-Vent Termination Kit.
- 5) Make gas connections. Refer to the "Gas Connection" section
 

Test the pilot. Must be as per diagram in the "Maintenance Instruction" section.

If converting to Propane, make changes prior see the "Conversion from Natural Gas to Propane" section.
- 6) Test Gas Pressure. Refer to the "Gas Pipe Pressure Testing" section.
- 7) Install standard and optional features. Refer to the following sections where applicable:
  - a. Log Set Installation
  - b. Double Door Installation
  - c. Decorative Door Grill Installation
  - d. Tile Inset Installation
  - e. Wall Thermostat
  - f. Remote Control
- 8) Final check. Refer to the "Final Check" section.
 

Before leaving this unit with the customer, the installer must ensure that the appliance is firing correctly and **operation fully explained to customer**.

### This includes:

- 1) Locking the appliance to ensure the correct firing rate (rate noted on label) after burning appliance for 15 minutes.
- 2) If required, adjusting the primary air to ensure that the flame does not carbon. First allow the unit to burn for 15-20 min. to stabilize.

**CAUTION: Any alteration to the product that causes sooting or carboning that results in damage is not the responsibility of the manufacturer.**

## CLEARANCES TO COMBUSTIBLES

The clearances listed are MINIMUM distances. Measure the clearance to both the appliance and the chimney connector. **The farthest distance is correct if the two clearances do not coincide.**

For example, if the appliance is set as indicated in one of the figures but the connector is too close, move the stove until the correct clearance to the connector is obtained.

This appliance may be installed only with the clearances as shown in the situations pictured. **Do not combine clearances from one type of installation with another in order to achieve closer clearances.**

This unit can be installed on a solid combustible surface like a wood floor. This unit can also be installed directly on carpeting or vinyl.

Use the minimum clearances shown in the diagrams below:

### H35-NG1 & H35-LP1 Clearances

A Side Wall to Unit	6-1/2" / 165 mm
B Back Wall to Unit	6" / 152 mm
C Vertical Vent Pipe to Back Wall	2" / 50 mm
E Unit Corner to Wall	2" / 50 mm
Unit Top to Alcove Ceiling	36" / 914 mm

Minimum ceiling height is 36" / 914 mm from top of unit.

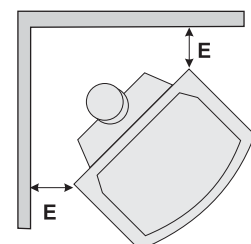
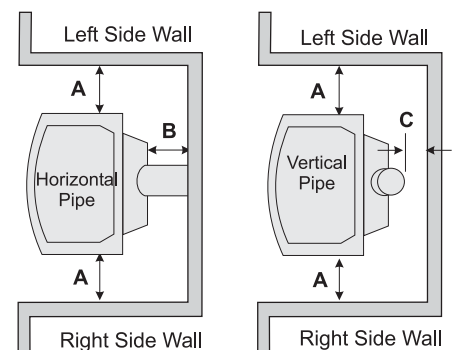



# INSTALLATION

## LOCATING YOUR GAS STOVE

When selecting a location for your stove, ensure that the clearances listed above are met as well as ensuring that there is adequate accessibility for servicing and proper operation.

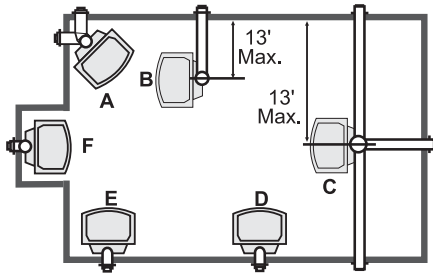

- A) Cross Corner
- B) Room Divider
- C) Island
- D) Flat on Wall
- E) Flat on Wall Corner
- F) Flush with Wall/Alcove

For Vent Termination requirements, see the "Exterior Vent Terminal Locations" section.

## MANUFACTURED MOBILE HOME ADDITIONAL REQUIREMENTS

- 1) Ensure that structural members are not cut or weakened during installation.
- 2) Ensure proper grounding using the #8 ground lug provided.
- 3) Appliance must be anchored to the floor with the supplied anchoring methods.

## COMBUSTION AND VENTILATION AIR

The combustion air from this appliance is drawn from outside the building through the outer flue. **Extra provision for combustion air inside the room is not required.**

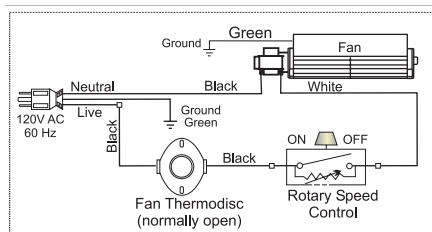

## OPTIONAL FAN INSTALLATION

Fan Kit Contains:

Qty.	Description
1	Fan Speed Controller with nut, and knob.
1	Fan Assembly c/w green wire attached
1	Power cord
1	Plastic locking grommet

- 1) Remove the Top Control Panel Assembly by removing the three screws. Diagram 1.

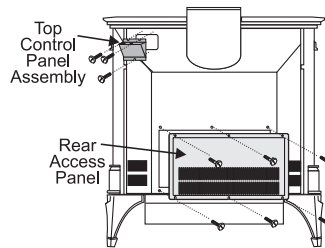

Diagram 1

- 2) Remove the nylon hole plug from the control panel.
- 3) Install the fan speed controller onto the control panel and secure with nut. Connect remaining wire harness wires to speed control. **NOTE:** Speed control wires must be in the down position when control panel is in place.
- 4) Push black knob onto speed control.
- 5) Remove the rear access panel on the back of the stove by removing the 6 screws. Install the fan onto pins as per Diagram 2.

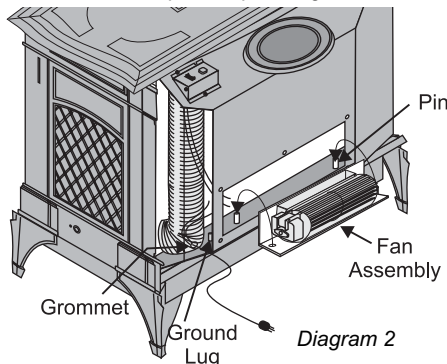

Diagram 2

**NOTE:** Do NOT damage, cut or remove the 3" aluminum air intake pipes.

*Hint for pushing fan down onto pins - rub a bit of dish soap on the pins so the grommets will slide down more easily. Check to make sure the fan is seated properly on the pins - try to move the fan back and forth.*

- 6) Push power cord through hole in the rear panel 14" - 16" and tie a loose knot in the cord on the inside to prevent the power cord from being pulled out. Diagram 2.

- 7) Install locking grommet to power cord and push through hole in the rear panel and give a 1/4 turn to secure.

**NOTE:** When running wires, keep them clear of valve assembly and tubing to avoid tangling of wires and valve.

**NOTE:** Be careful not to cut wires when passing through holes in the firebox.

- 8) Run green ground wire from fan and connect to grounding lug.

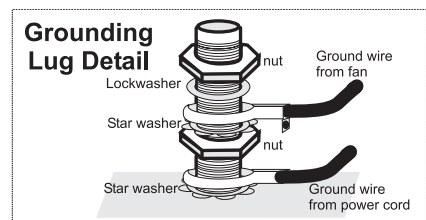

- 9) Connect green power cord ground wire to grounding lug.

- 10) Run the neutral black wire from power cord and connect to fan motor.

- 11) Run the live black wire from power cord and connect to speed control wire.

- 12) Connect the white wire of the wire harness to the fan terminal.

**NOTE:** Pull excess wire next to fan to avoid excessive heat from the firebox.

- 13) Ensure all wires are pulled away from firebox to avoid excessive heat and secure with stick-on wire clip.

- 14) Re-attach control panel with 3 screws, reversing step 1. Re-attach rear access panel with 6 screws, reversing step 5.

**NOTE:** When power cord is plugged in, speed control is in the ON position and stove is burning, allow 10 - 15 minutes for the thermidisc (temperature switch) to activate and turn on the Fan automatically.

### WARNING:

**Electrical Grounding Instructions**  
This appliance is equipped with a three pronged (grounding) plug for your protection against shock hazard and should be plugged directly into a properly grounded three-prong receptacle. Do not cut or remove the grounding prong from this plug.



## VENTING INTRODUCTION

The Horizontal Termination Kit and the Simpson Dura-Vent Direct Vent System Model DV-GS venting systems, in combination with the Direct Vent Freestanding Gas Stoves, H35-NG1, and H35-LP1, have been tested and listed as direct vent heater systems by Warnock Hersey.

These units use the "balanced flue" technology Co-Axial system. The inner liner vents products of combustion to the outside while the outer pipe draws outside combustion air into the combustion chamber thereby eliminating the need to use heated room air for combustion and losing warm room air up the chimney.

**Note: These flue pipes must not be connected to any other appliance.**

The gas appliance and vent system must be vented directly to the outside of the building, and never be attached to a chimney serving a separate solid fuel or gas burning appliance. Each direct vent gas appliance must use its own separate vent system. Common vent systems are prohibited.

### IMPORTANT

Read all instructions carefully before starting the installation. Failure to follow these instructions may create a fire or other safety hazard, and will void the warranty. Be sure to check the venting and clearance to combustible requirements. Consult your local building codes before beginning installation.

The location of the termination cap must conform to the requirements in the "Exterior Vent Terminal Locations" section.

## INSTALLATION PRECAUTIONS

These venting systems are engineered products that have been designed and tested for use with the H35-NG1, and H35-LP1. The warranty will be voided and serious fire, health or other safety hazards may result from any of the following actions:

- 1) Installation of any damaged Direct Vent component
- 2) Unauthorized modification of the Direct Vent System
- 3) Installation of any component part not manufactured or approved by Simpson Dura-Vent or FPI Fireplace Products International Ltd.
- 4) Installation other than as instructed by Simpson Dura-Vent and FPI Fireplace Products International Ltd.

**Warning: Always maintain required clearances (air spaces) to nearby combustibles to prevent a fire hazard. Do not fill air spaces with insulation.**

Be sure to check the vent termination clearance requirements from decks, windows, soffits, gas regulators, air supply inlets and public walkways as specified in the "Exterior Vent Terminal Locations" section and in your local building codes.

**The gas appliance and vent system must be vented directly to the outside of the building, and never be attached to a chimney serving a separate solid fuel or gas-burning appliance.** Each direct vent gas appliance must use its own separate vent system. Common vent systems are prohibited.

## VENT RESTRICTOR POSITION

Vent restriction is required for certain venting installations, see the diagrams in "Venting Arrangement" section to determine if they are required for your installation.

To set the Vent restriction as indicated in the diagrams in the "Venting Arrangement" section, simply loosen the screws and push the vent restrictor plate to the correct position. Tighten the screws.

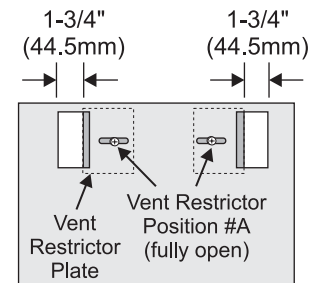

*Horizontal Termination:  
Vent Restrictor setting at 36,000 Btu/h*

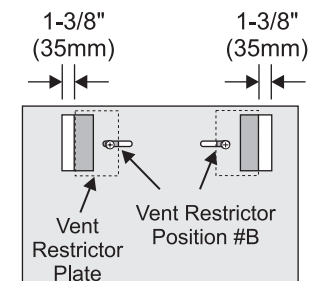

*Vertical Termination:  
Vent Restrictor setting at 36,000 Btu/h*

## SAFETY PRECAUTIONS FOR THE INSTALLER

- 1) Wear gloves and safety glasses for protection.
- 2) Exercise extreme caution when using ladders or on roof tops.
- 3) Be aware of electrical wiring locations in walls and ceilings.

# INSTALLATION

## EXTERIOR VENT TERMINAL LOCATIONS

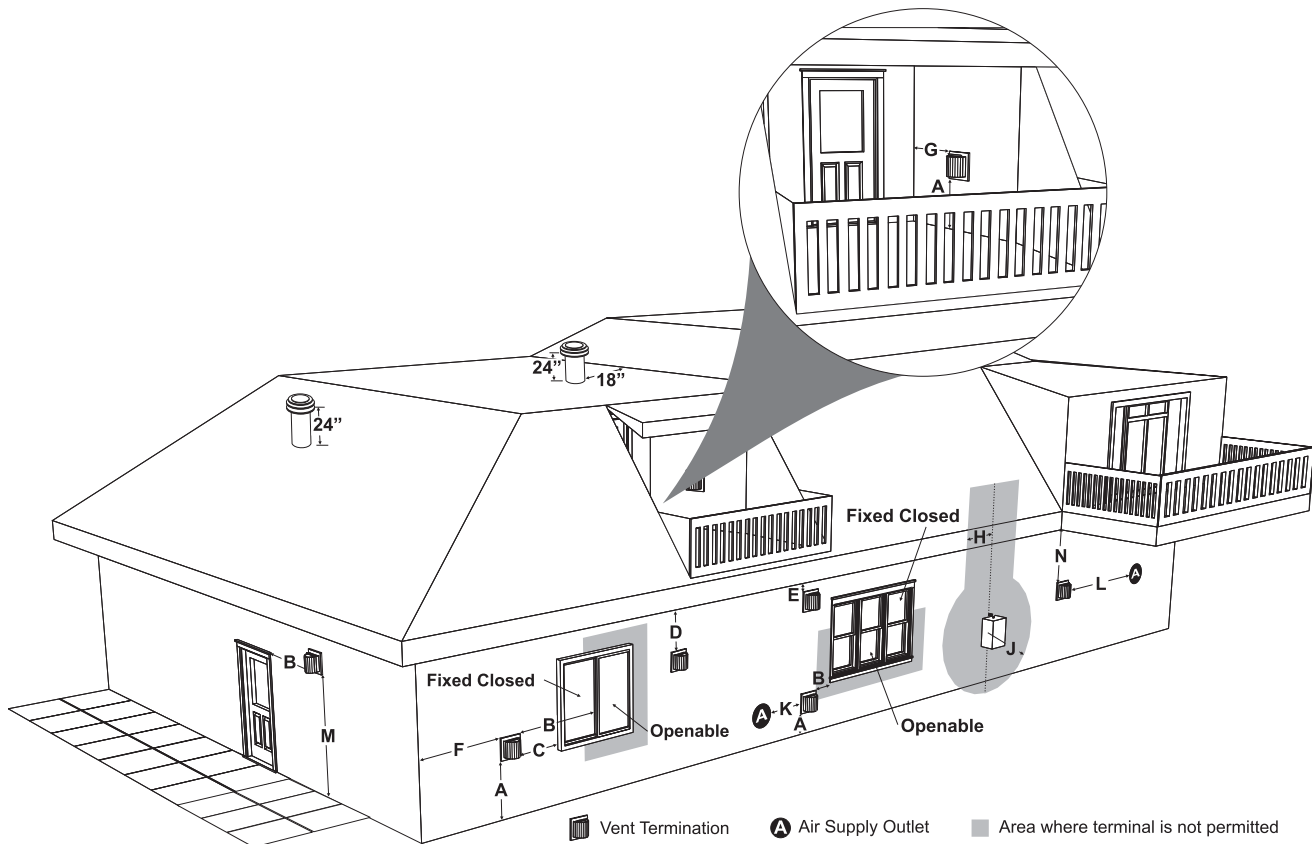

- A= Clearance above grade, veranda, porch, deck, or balcony \*(min. 12"/30cm)
- B= Clearance to window or door that may be opened \*(12"/30cm)
- C= Clearance to permanently closed window \*(min. 12"/30cm)
- D= Vertical clearance to ventilated soffit located above the terminal within a horizontal distance of (24"/60cm) from the centerline of the terminal (min. 22"/55cm) check with local code.
- E= Clearance to unventilated soffit (min. 12"/30cm)
- F= Clearance to outside corner: with AstroCap Termination Cap (min. 6"/15cm), with Dura-Vent Termination Cap (min.12"/30cm), with Riser Vent (min. 6"/15cm)
- G= Clearance to inside corner: with AstroCap Termination Cap (min. 6"/15cm), with Dura-Vent Termination Cap (min.12"/30cm), with Riser Vent (min. 6"/15cm)
- H= Not to be installed above a meter/regulator assembly within (3'/90cm) horizontally from the centerline of the regulator.
- J= Clearance to service regulator vent outlet \*(min. 36"/90cm)
- K= Clearance to non-mechanical air supply inlet to building or the combustion air inlet to any other appliance \*(12"/30cm)
- L= Clearance to a mechanical air supply inlet \*(min. 72"/1.8m)
- M= \*\*Clearance above paved sidewalk or a paved driveway located on public property \*(min. 84"/2.1m)
- N= Clearance under veranda, porch, deck, or balcony \*(min. 12"/30cm)\*\*\*

Note: \* As specified in CGA B149 Installation Code. Note: Local codes or regulations may require different clearances.

\*\*A vent shall not terminate directly above a sidewalk or paved driveway which is located between two single family dwellings and serves both dwellings.

\*\*\*Only permitted if veranda, porch, deck, or balcony is fully open on a minimum of two sides beneath the floor.

## 4" X 6-5/8" RIGID PIPE CROSS REFERENCE CHART

Components from different Manufacturers may not be mixed. Not All Rigid Pipe components are available directly from FPI.

Description	Simpson Direct Vent Pro®	Simpson Direct Vent GS® Discontinued	Selkirk Direct-Temp™	American Metal Products® Amerivent Direct	Metal-Fab® Sure Seal	Security Secure Vent®
6" Pipe Length, Galvanized	46DVA-06	908	4DT-6	N/A	4D6	SV4L6
6" Pipe Length, Black	46DVA-06B	908B	4DT-6B	N/A	4D6B	SV4LB6
7" Pipe Length, Galvanized	N/A	N/A	N/A	4D7	N/A	N/A
7" Pipe Length, Black	N/A	N/A	N/A	4D7B	N/A	N/A
9" Pipe Length, Galvanized	46DVA-09	907	4DT-9	N/A	N/A	N/A
9" Pipe Length, Black	46DVA-09B	907B	4DT-9B	N/A	N/A	N/A
12" Pipe Length, Galvanized	46DVA-12	906	4DT-12	4D12	4D12	SV4L12
12" Pipe Length, Black	46DVA-12B	906B	4DT-12B	4D12B	4D12B	SV4LB12
18" Pipe Length, Galvanized	46DVA-18	N/A	4DT-18	N/A	4D18	SV4LA
18" Pipe Length, Black	46DVA-18B	N/A	4DT-18B	N/A	4D18B	SV4LA
24" Pipe Length, Galvanized	46DVA-24	904	4DT-24	4D2	4D24	SV4L24
24" Pipe Length, Black	46DVA-24B	904B	4DT-24B	4D2B	4D24B	SV4LB24
36" Pipe Length, Galvanized	46DVA-36	903	4DT-36	4D3	4D36	SV4L36
36" Pipe Length, Black	46DVA-36B	903B	4DT-36B	4D3B	4D36B	SV4LB36
48" Pipe Length, Galvanized	46DVA-48	902	4DT-48	4D4	4D48	SV4L48
48" Pipe Length, Black	46DVA-48B	902B	4DT-48B	4D4B	4D48B	SV4LB48
60" Pipe Length, Galvanized	46DVA-60	N/A	N/A	N/A	N/A	N/A
60" Pipe Length, Black	46DVA-60B	N/A	N/A	N/A	N/A	N/A
Adjustable Length 3"-10", Galvanized	N/A	N/A	N/A	N/A	4DAL	N/A
Adjustable Length 3"-10", Black	N/A	N/A	N/A	N/A	4DALB	N/A
Adjustable Length 11"-14", Galvanized	Disc - See 46DV-08A	N/A	4DT-AJ	N/A	N/A	N/A
Adjustable Length 11"-14", Black	Disc - See 46DV-08AB	911B	4DT-AJB	N/A	N/A	N/A
Adjustable Length 17"-24", Galvanized	Disc - See 46DV-16A	917 - N/A from FPI	N/A	N/A	N/A	N/A
Adjustable Length 17"-24", Black	Disc - See 46DV-16AB	917B	N/A	N/A	N/A	SV4LBA24
Adjustable Length 7", Galvanized	N/A	N/A	N/A	4D7A	N/A	N/A
Adjustable Length 7", Black	N/A	N/A	N/A	4D7AB	N/A	N/A
Extension Pipe 8-1/2", Galvanized	46DVA-08A	N/A	N/A	N/A	N/A	N/A
Extension Pipe 8-1/2", Black	46DVA-08AB	N/A	N/A	N/A	N/A	N/A
Adjustable Length 12", Galvanized	N/A	N/A	N/A	4D12A	N/A	SV4LA12
Adjustable Length 12", Black	N/A	N/A	N/A	4D12AB	N/A	SV4LBA12
Extension Pipe 16", Galvanized	46DVA-16A	N/A	N/A	N/A	N/A	N/A
Extension Pipe 16", Black	46DVA-16AB	N/A	N/A	N/A	N/A	N/A
45° Elbow, Galvanized	46DVA-E45	945	4DT-EL45	4D45L	N/A	N/A
45° Elbow, Black	46DVA-E45B	945B	4DT-EL45B	4D45LB	N/A	N/A
45° Elbow, Swivel, Galvanized	Disc - See 46DVA-E45	945G	N/A	N/A	4D45L	SV4E45
45° Elbow, Swivel, Black	Disc - See 46DVA-E45B	945BG	N/A	N/A	4D45LB	SV4EB45
90° Elbow, Galvanized	46DVA-E90	990	4DT-EL90S	4D90LS	N/A	N/A
90° Elbow, Black	46DVA-E90B	990B	4DT-EL90SB	4D90LBS	N/A	SV4EBR90-1
90° Elbow, Swivel, Galvanized	Disc - See 46DVA-E90	990G	N/A	N/A	4D90L	SV4E90-1
90° Elbow, Swivel, Black	Disc - See 46DVA-E90B	990BG	N/A	N/A	4D90LB	SV4EB90-1
90° Starter Elbow, Swivel, Galvanized*	N/A	N/A	N/A	N/A	4D90A	N/A
Adaptor*	N/A	N/A	N/A	N/A	4DDA	N/A
Ceiling Support	N/A	949 - N/A from FPI	4DT-CS	4DFSP	4DSP	SV4SD
Cathedral Support Box	46DVA-CS	941	4DT-CSS	4DRSB	4DRS	SV4CSB
Wall Support/Band	46DVA-WS	988	4DT-WS/B	4DWS	4DWS	SV4BM
Offset Support	46DVA-ES - N/A from FPI	989 - N/A from FPI	4DT-OS	N/A	N/A	SV4SU
Wall Thimble, Black	46DVA-WT	942	4DT-WT	4DWT	4DWT	SV4RSM
Wall Thimble Support Box/Ceiling Support	46DVA-DC	N/A	N/A	N/A	N/A	SV4PF
Firestop Spacer	46DVA-FS	963	4DT-FS	4DFSP	4DFS	SV4BF
Trim Plate, Black	N/A	N/A	4DT-TP	4DFPB	4DCP	SV4LA
Masonry Chimney Flashing	N/A	N/A	N/A	N/A	N/A	N/A
Brass Trim for Wall Thimble/Ceiling Support	DISC.	3951	N/A	N/A	N/A	N/A

# INSTALLATION

## 4" x 6-5/8" Rigid Pipe Cross Reference Chart (Cont.)

Components from different Manufacturers may not be mixed. Not All Rigid Pipe components are available directly from FPI.

Description	Simpson Direct Vent Pro®	Simpson Direct Vent GS® Discontinued	Selkirk Direct-Temp™	American Metal Products® Amerivent Direct	Metal-Fab® Sure Seal	Security Secure Vent®
Attic Insulation Shield 12"	46DVA-IS - N/A from FPI	N/A	N/A	4DAIS12	N/A	SV4RSA
Attic Insulation Shield - Cold Climates 36"	N/A	N/A	N/A	4DAIS36	N/A	N/A
Basic Horizontal Termination Kit (A)	DISC. 46DVA-KHA	970	4DT-HKA	4DHTK2	4DHTKA	SV - SHK
Horizontal Termination Kit (B)	(Changed Components)	971	4DT-HKB	4DHTK1	4DHTKB	SV - HK
Vertical Termination Kit	DISC.	978	4DT-VKC	4DVTK	4DVTK	SV - FK
High Wind Vertical Cap	46DVA-VCH	991	N/A	N/A	N/A	N/A
High Wind Horizontal Cap	46DVA-HC	985	N/A	N/A	N/A	N/A
Horizontal Square Termination Cap	Disc - See 46DVA-HC	984	4DT-HHC	4DHC	4DHT	SV4CHC-1
Vertical Termination Cap	46DVA-VC	980	4DT-HVC	4DVC	4DVT	SV4CGV-1
Storm Collar	46DVA-SC	953	4DT-SC	4DSC	4DSC	SV4FC
Adjustable Flashing, 0/12-6/12	46DVA-F6	943	4DT-AF6	4DF	4DF	SV4FA
Adjustable Flashing, 6/12-12/12	46DVA-F12	943S	4DT-AF12	4DF12	4DF-12	SV4FB
Vinyl Siding Standoff	46DVA-VSS	950	4DT-VS	N/A	4DVS	SV4VS
Vinyl Siding Shield Plate	N/A	N/A	4DT-VSP	N/A	N/A	SV4VS
Snorkel Termination 14"	46DVA-SNK14	982	4DT-ST14	4D12S	4DST14	SV4STC14
Snorkel Termination 36"	N/A	981	4DT-ST36	4D36S	4DST36	SV4STC36
Restrictor Disk	46DVA-RD	929	N/A	N/A	N/A	N/A
Extended Vertical Termination Cap	46DVA-VCE	930	N/A	N/A	N/A	N/A
Chimney Conversion Kit A	46DVA-KCA	931	N/A	N/A	N/A	N/A
Chimney Conversion Kit B	46DVA-KCB	932	N/A	N/A	N/A	N/A
Chimney Conversion Kit C	46DVA-KCC	933	N/A	N/A	N/A	N/A
Chimney Conversion Kit Masonry	46DVA-KMC	934	N/A	N/A	N/A	N/A
Masonry Chimney Conversion Kit (includes: Cap Adapter 18"x18" Flashing)	46DVA-KCT	935	N/A	N/A	N/A	N/A
Wall Firestop	46DVA-WFS	947	N/A	N/A	N/A	N/A
Colinear Flex Connectors	46DVA-ADF	923F	N/A	N/A	N/A	N/A
<b>FPI</b>						
946-506/P	Vent Guard (Optional) for AstroCap	946-205	Vinyl Siding Shield for Riser Vent Terminal			
510-994	Rigid Pipe Adapter (Must use with all Rigid Piping)	946-208/P	Vent Guard (Optional) for Riser Vent Terminal			
640-530/P	Riser Vent Terminal	946-523/P	AstroCap Horizontal Cap			
		946-206	Vinyl Siding Standoff for AstroCap			

**\*NOTE:** When using Metal-Fab Sure Seal Rigid Piping please note that either the Adaptor (4DDA) or 90° Starter Elbow (4D90A) must be used in conjunction with FPI Rigid Pipe Adaptor (510-994).

### Offset Pipe Selection:

Use this table to determine offset pipe lengths.

Pipe Length	4" x 6-5/8" Venting	
	Run (X)	Rise (Y)
0"(0mm)	4-7/8"(124mm)	13-3/8"(340mm)
6"(152mm)	8"(203mm)	16-1/2"(419mm)
9"(229mm)	10-1/8"(257mm)	18-5/8"(473mm)
12"(305mm)	12-1/4"(311mm)	20-3/4"(527mm)
24"(610mm)	20-5/8"(524mm)	29-1/8"(740mm)
36"(914mm)	29"(737mm)	37-1/2"(953mm)
48"(1219mm)	37-7/16"(951mm)	45-15/16"(1167mm)

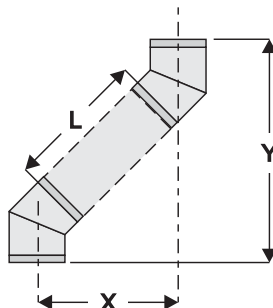

For specific instructions or details on particular venting components please visit the following websites:

**Simpson Direct Vent Pro:** [www.duravent.com](http://www.duravent.com)

**Selkirk Direct-Temp:** [www.selkirkcorp.com](http://www.selkirkcorp.com)

**American Metal Products Amerivent Direct:**  
[www.americanmetalproducts.com](http://www.americanmetalproducts.com)

**Metal-Fab Sure Seal:** [www.mtlfab.com](http://www.mtlfab.com)

**Security Secure Vent:** [www.securitychimneys.com](http://www.securitychimneys.com)

**\*NOTE:** Horizontal runs of vent must be level, or have a 1/4 inch rise for every 1 foot of run towards the termination. Never allow the vent to run downward. This could cause high temperatures and may present a possible fire hazard.

## RIGID PIPE VENTING SYSTEMS *Horizontal or Vertical Terminations*

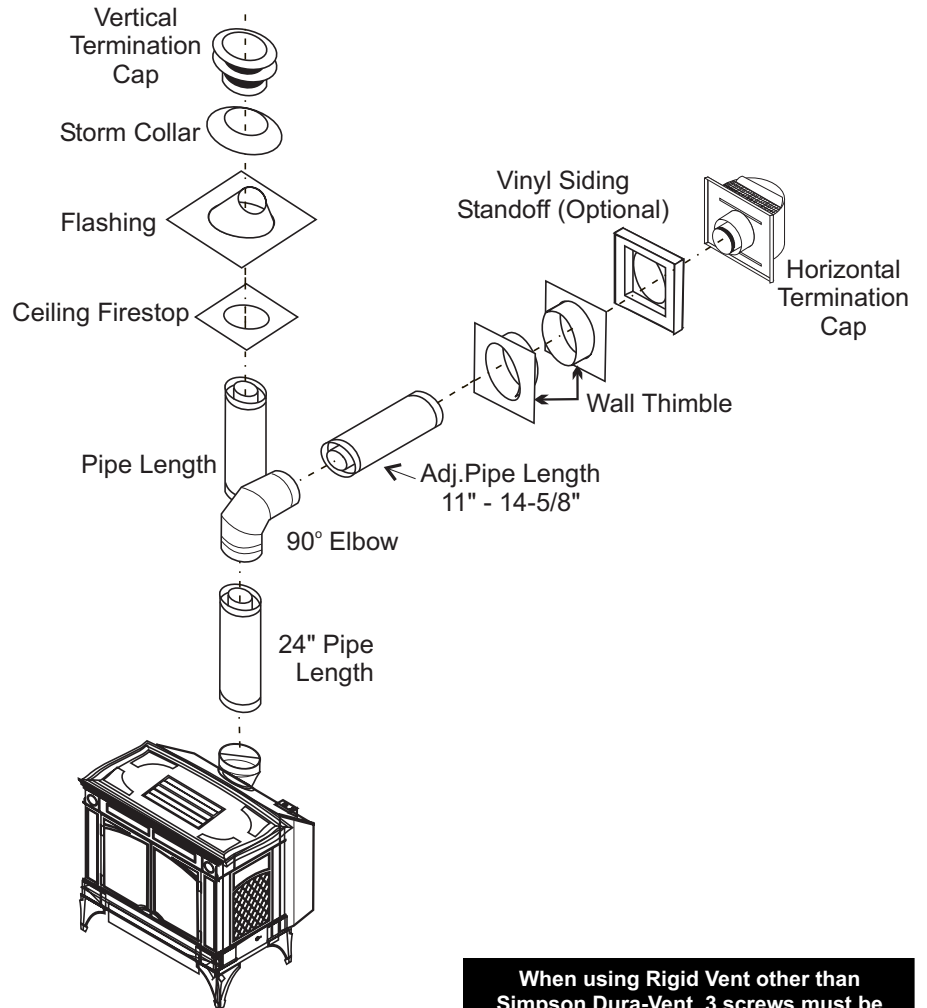
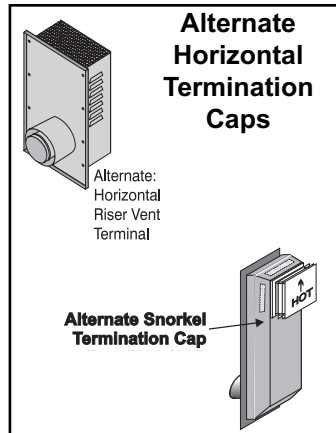

### **WARNING:**

Do not combine venting components from different venting systems.

However use of the the AstroCap™ and FPI Riser is acceptable with all systems.

This product has been evaluated by Intertek for use with DuraVent Direct-Vent GS, Selkirk Direct-Temp, Ameri Vent Direct venting and Security Secure Vent systems.

**When using Rigid Vent other than Simpson Dura-Vent, 3 screws must be used to secure rigid pipe to adaptor.**

The FPI AstroCap™ and FPI Riser Vent terminal are certified for installations using FPI venting systems as well as Simpson Dura-Vent® Direct Vent GS, American Metal Products Ameri Vent Direct Vent, Security Secure Vent®, Selkirk Direct-Temp. AstroCap™ is a proprietary trademark of FPI Fireplace Products International Ltd. Dura-Vent® and Direct Vent GS are registered and/or proprietary trademarks of Simpson Dura-Vent Co. Inc.

# INSTALLATION

## ROTATING 45° ELBOW FOR STRAIGHT HORIZONTAL TERMINATIONS

1) Remove all 4 screws that secure the elbow to the unit using a 1/4" magnetic nut driver.



Remove all 4 screws and washers

2) Rotate the elbow 180°



3) Secure the elbow by securing it with the 4 screws.

## VENTING ARRANGEMENTS

### Horizontal Terminations for All Venting Systems

The shaded areas in the diagram below show all allowable combinations of vertical runs with horizontal terminations. Maximum one 90° elbow (two 45° elbows equal one 90° elbow).

### Propane and Natural Gas: Residential, Manufactured and Mobile Homes Installations

The venting arrangements diagrammed below, have a min. of 75% (flue loss) efficiency with Fan Off, as required for manufactured homes. (Actual efficiency may be as high as 85%)

May be installed in Manufactured (Mobile) Homes after first sale.

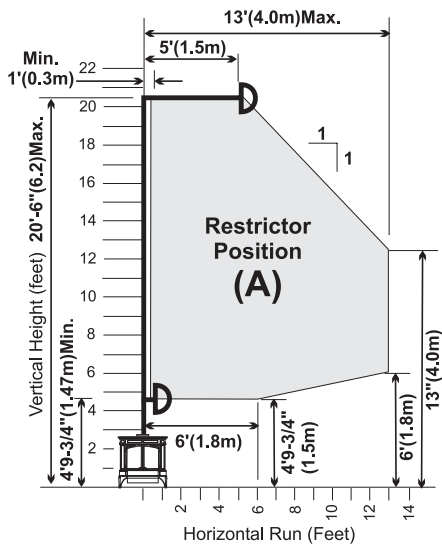

**NOTE: See "Vent Restrictor Position" section for installation instructions for the Vent Restrictor Position.**

### Vertical Terminations Systems for Residential Manufactured and Mobile Homes

The shaded area in the diagram below shows all allowable combinations of straight vertical and offset to vertical runs with vertical terminations. Maximum two 45° elbows.

If the vent is ENCLOSED in a chase (min. size 9" x 9") maintain a 1-1/4" clearance to combustibles.

May be installed in Manufactured (Mobile) Homes after first sale.

### Offset to Vertical Terminations

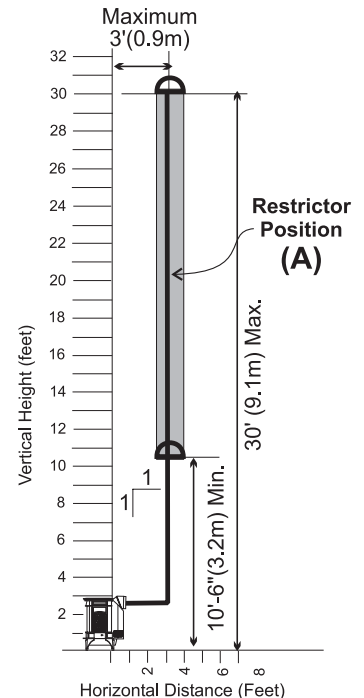
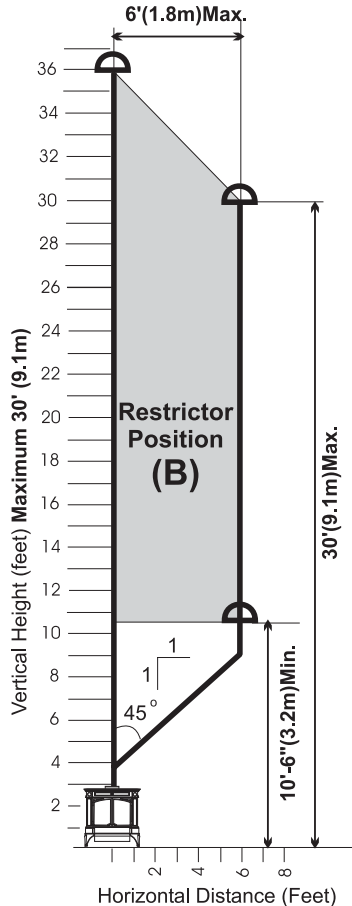



## VENTING ARRANGEMENTS HORIZONTAL TERMINATIONS USING RIGID PIPE

The two diagrams show all allowable combinations of straight horizontal termination using Rigid Pipe. Restrictor position "A".

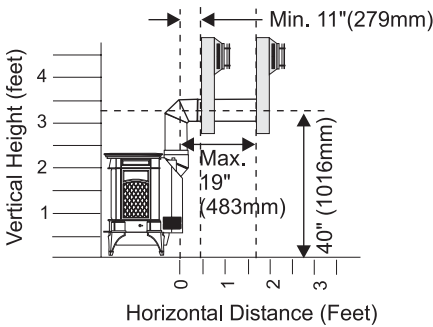

*Dura-Vent Snorkel Termination*

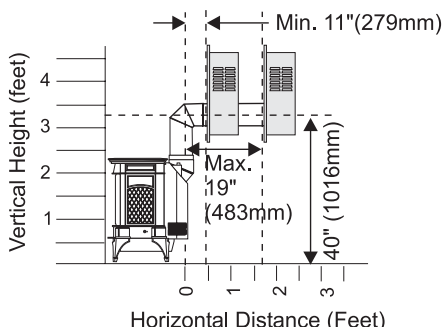

*Riser Vent Termination*

### Venting Arrangements -Straight Horizontal Termination at a De-Rated BTU

The diagrams show all allowable combinations of straight horizontal termination using Rigid Pipe. Restrictor position "A". Refer to the "Conversion Kit to Lower BTU Rating" section for de-rating instructions.

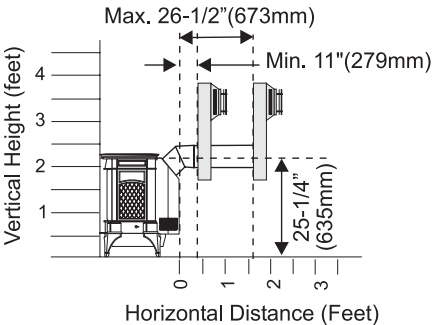

*Dura-Vent Snorkel Termination*

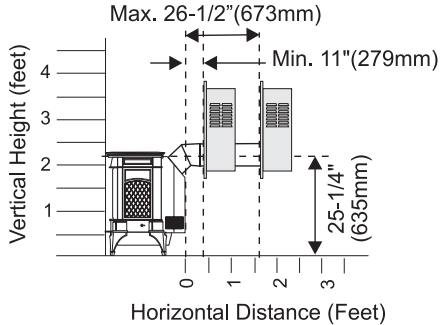

*Riser Vent Termination*

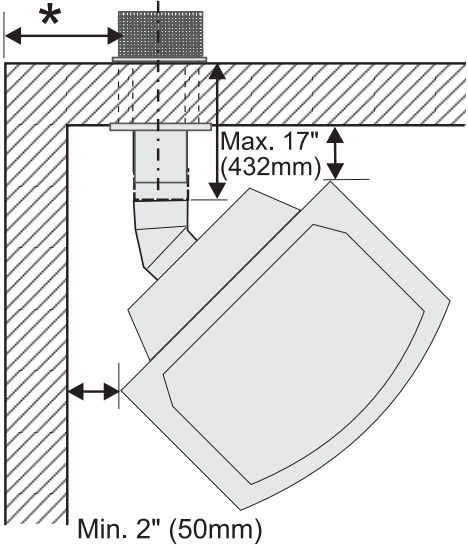

\*If this is an outside corner, the minimum distance between the vent and the outside corner is 6" (15cm). See "F" on the diagram in the "Exterior Vent Terminal Locations" section.

# INSTALLATION

## Horizontal Venting with Two (2) 90° Elbows

One 90° elbow = Two 45° elbows.

Option	V	H + H1	With these options, maximum total pipe length is 30 feet with minimum of 8 feet total vertical and maximum 8 feet total horizontal. <b>Please note minimum 1 foot between 90° elbows is required.</b>
A)	3' Min.	2' Max.	
B)	4' Min.	3' Max.	
C)	5' Min.	4' Max.	
D)	6' Min.	5' Max.	
F)	8' Min.	8' Max.	

Lengths do not include elbow indicated

Vent restrictor position A (fully open), refer to the "Vent Restrictor Position" section.

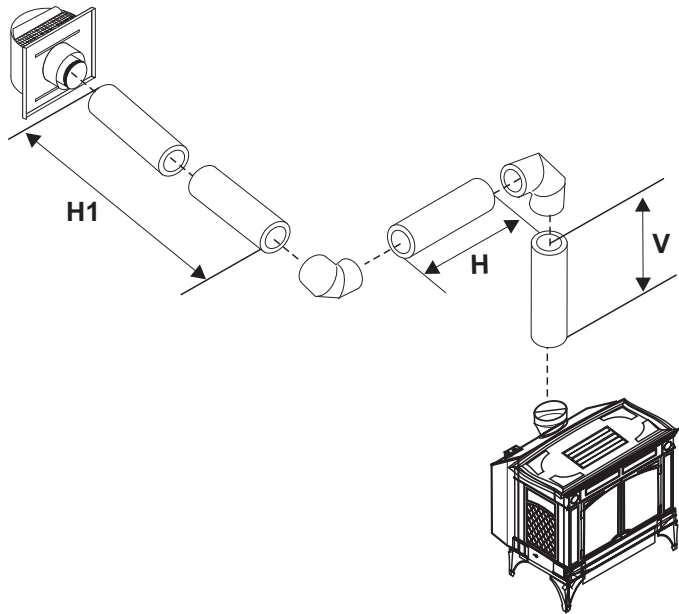

## Horizontal Venting with Two (2) 90° Elbows

One 90° elbow = Two 45° elbows.

Option	H	V	H + H1	With these options, max. total pipe length is 30 feet with min. of 9 feet total vertical and max. 8 feet total horizontal. <b>Please note min. 1 foot between 90° elbows is required.</b>
A)	1' Max.	2' Min.	3' Max.	
B)	2' Max.	3' Min.	5' Max.	
C)	3' Max.	5' Min.	6' Max.	
D)	4' Max.	7' Min.	7' Max.	
E)	5' Max.	9' Min.	8' Max.	

Lengths do not include elbow indicated

Vent restrictor position A (fully open), refer to the "Vent Restrictor Position" section.

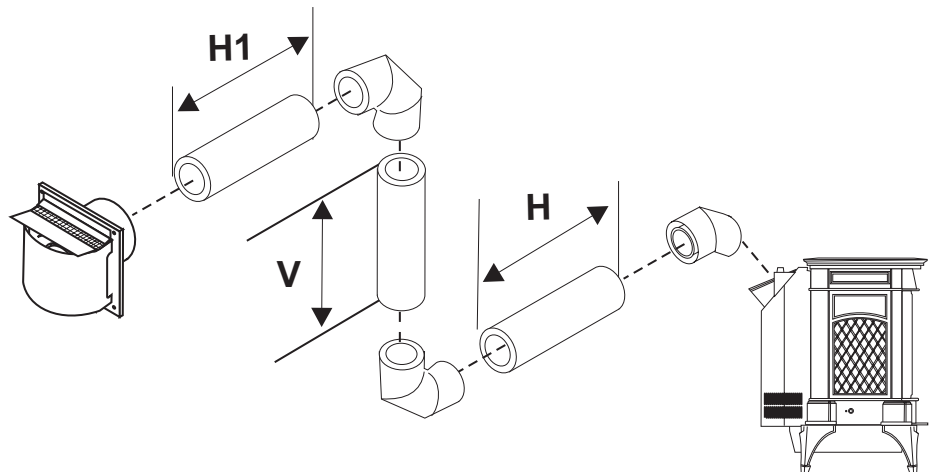

## Vertical Venting with Two (2) 90° Elbows

One 90° elbow = Two 45° elbows.

Option	V	H	V + V1	With these options, max. total pipe length is 30 feet with min. of 6 feet total vertical and max. 7 feet total horizontal. <b>Please note min. 1 foot between 90° elbows is required.</b>
A)	1' Min.	3' Max.	2' Min.	
B)	2' Min.	4' Max.	3' Min.	
C)	3' Min.	5' Max.	4' Min.	
D)	4' Min.	6' Max.	5' Min.	
E)	5' Min.	7' Max.	6' Min.	

Lengths do not include elbow indicated

Vent restrictor position A (fully open), refer to the "Vent Restrictor Position" section.

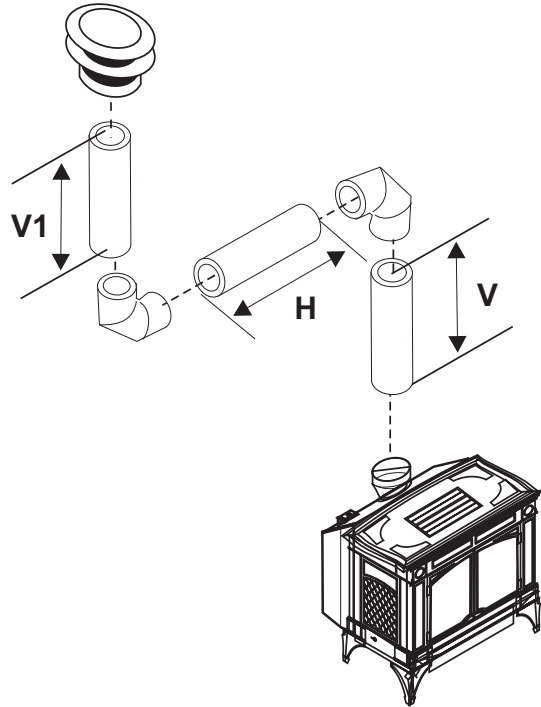

## Vertical Venting with Two (2) 90° Elbows

One 90° elbow = Two 45° elbows.

Option	H + H1	V	With these options, max. total pipe length is 30 feet with min. of 6 feet total vertical and max. 6 feet total horizontal. <b>Please note min. 1 foot between 90° elbows is required.</b>
A)	2' Max.	2' Min.	
B)	3' Max.	3' Min.	
C)	4' Max.	4' Min.	
D)	5' Max.	5' Min.	
E)	6' Max.	6' Min.	

Lengths do not include elbow indicated

Vent restrictor position A (fully open), refer to the "Vent Restrictor Position" section.

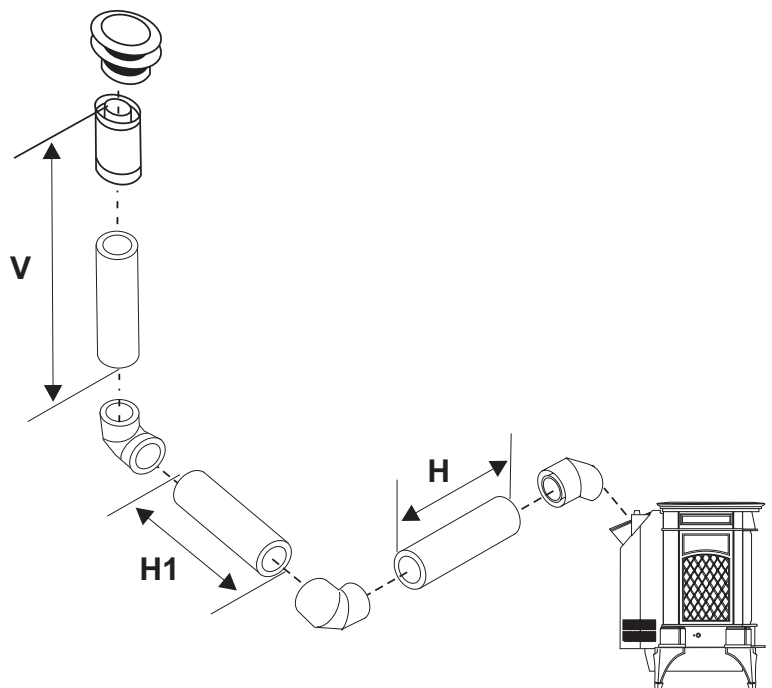

# INSTALLATION

## VERTICAL TERMINATION WITH CO-LINEAR FLEX SYSTEM

**THE APPLIANCE MUST NOT BE CONNECTED TO A CHIMNEY FLUE SERVING A SEPARATE SOLID FUEL BURNING APPLIANCE.**

Masonry chimneys may take various contours which the flexible liner will accommodate. However, **keep the flexible liner as straight as possible**, avoid unnecessary bending.

The Air Intake pipe must be attached to the inlet air collar of the termination cap.

This appliance is designed to be attached to two 3" (76mm) co-linear aluminium flex running the full length of the chimney. See the Venting Arrangements chart below for minimum and maximum flue lengths. See chart below for minimum distances from roof. Periodically check that the vent is unrestricted.

### Required Parts:

Part #	Description
946-529	Co-linear DV Vertical Termination Cap
948-305	3" Flex - 35 ft.
946-563	Co-Axial to Co-Linear Adapter Kit which contains the following: Co-linear Flex Adapter (270-585) Outer Pipe (946-257) Inner Pipe Adapter (946-219)

### Alternate Approved Caps

980	Vertical Termination Cap
991	High Wind Cap
923GK	3" Co-linear Adapter with flashing

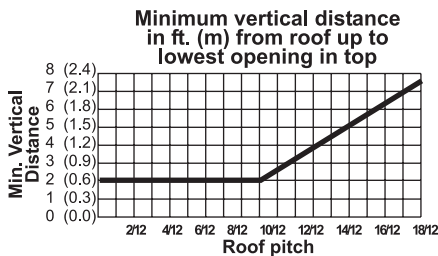

### Venting Arrangements - Vertical Terminations with Co-linear Flex System for both Residential & Manufactured Homes into Masonry Fireplaces

The shaded area in the diagram shows the allowable vertical terminations. Note: Must remove 4 screws from stove collar and rotate 180° to have collar facing straight back. Secure into place with 4 screws.

#### Straight Vertical Terminations

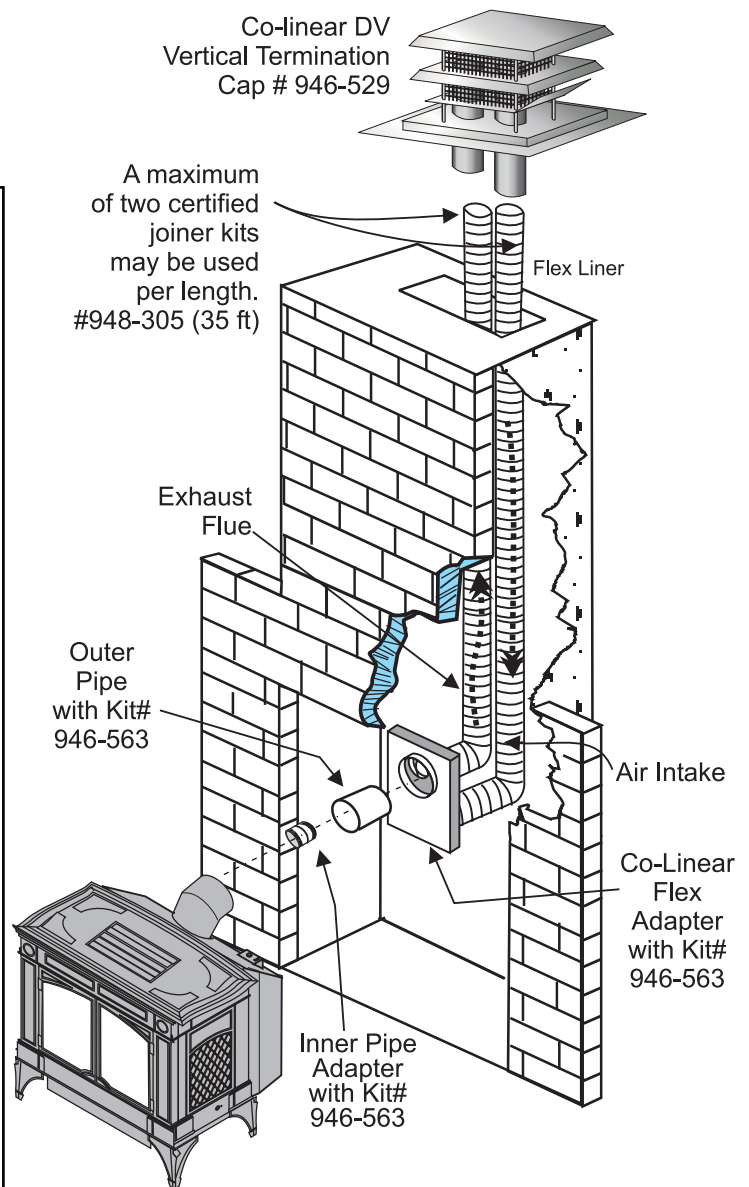
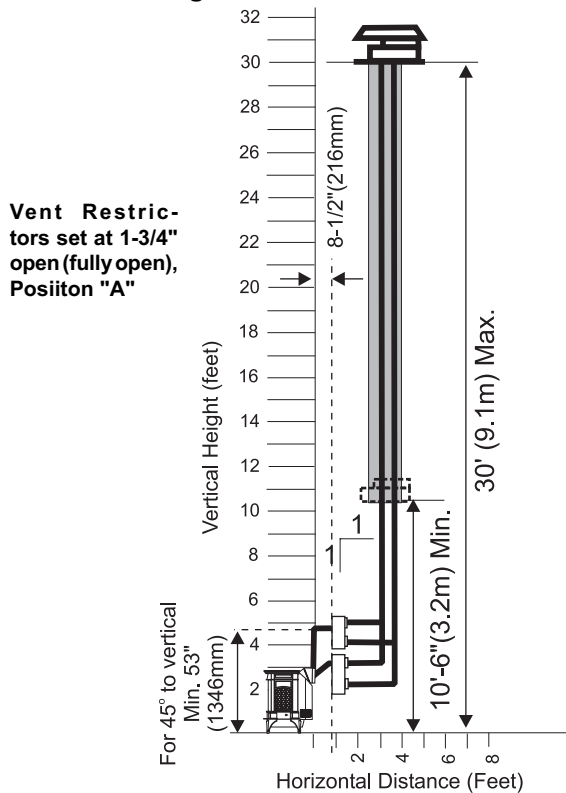

## DV STOVE HORIZONTAL VENT KIT

DV 2 ft. Stove Vent Kit (Part # 946-116) and DV 4 ft. Stove Vent Kit (Part #946-216) includes all the parts needed to install the H35 Direct Vent unit with minimum horizontal and vertical vent dimensions. For installations that require longer vertical and/or horizontal vents use the Dura-Vent system as shown in the "Dura-Vent Termination Kit" and "Dura-Vent Venting Components" sections.

Qty.	Description
1)	1 Rigid Pipe Section (Kit # 946-116: 2 ft. (1.2m) length, Kit # 946-216: 4 ft. (1.2m) length), 6-1/2" (165mm) inside diameter
2)	1 Flex Liner, compressed aluminium 2 ply liner, 4" (102mm) inside diameter
3)	4 Spring Spacers
4)	1 90 deg. Elbow
5)	1 Adjustable pipe section 13-1/2" to 24" (343mm x 610mm), 2 pcs.
6)	1 Thimble Cover
7)	1 Wall Thimble (2 pcs.)
8)	1 Adapter
9)	1 <b>AstroCap</b> Termination Cap
10)	2 Trim Collars
11)	1 Tube of Mill-Pac, high temperature sealant
12)	12 Screws, #8 x 1/2" Self tapping, Stainless Steel
13)	14 Screws, #8 x 1/2" Self tapping, Black
14)	4 Screws #8 x 1-1/2" Drill Point, Black
15)	4 Screws #8 x 1-1/2" Drill Point, Stainless Steel
16)	8 Wood screws #8 x 1"

Required but not included in above Kit:  
45° Elbow (Part #: 946-214)

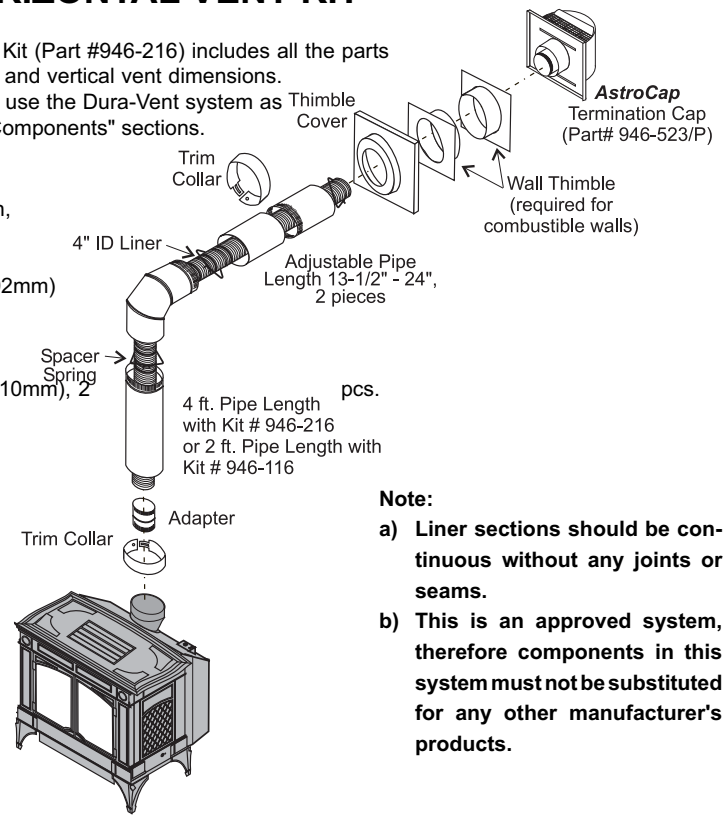

**Note:**

- a) Liner sections should be continuous without any joints or seams.
- b) This is an approved system, therefore components in this system must not be substituted for any other manufacturer's products.

## DV STOVE HORIZONTAL VENT KIT (#946-116 & #946-216) INSTALLATION

Review the following sequence of instructions which are typical of most installations. The sequence may vary depending on wall thickness. See "Exterior Vent Terminal Locations" to "Venting Arrangements" section for vent location and clearance dimensions, and the "Vent Restrictor Position" section to set the Vent Restrictor to the correct position.

- 1) Set the unit in its desired location. Check to determine if wall studs will be in the way of the venting system, adjust location until all clearances are met and there are no obstructions.

**Note:** A 1-1/2" (38mm) clearance around the outer pipe must be maintained except that only a 1" (25mm) clearance is needed at the termination end.

**IMPORTANT:**

**Do not locate termination hood where excessive snow or ice buildup may occur. Be sure to check vent termination area after snow falls, and clear to prevent accidental blockage of venting system. When using snow blowers, make sure snow is not directed towards vent termination area.**

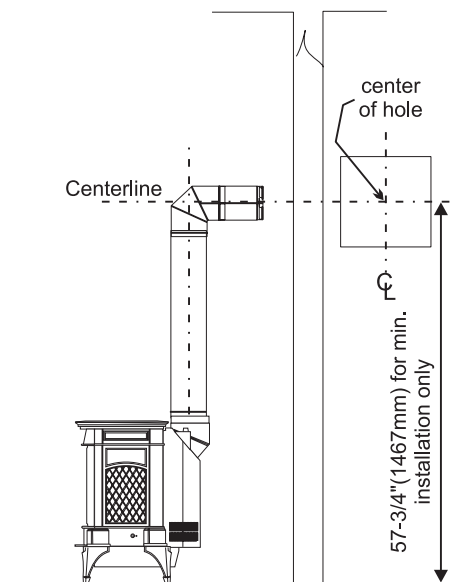

- 2) Assemble a trial fit to determine the vertical center-line for the vent termination.
  - a) Cut a 9-1/2" x 9-1/2" (241mm x 241mm) square hole on both the interior and exterior wall.

- b) Install wall thimbles on both interior and exterior wall with 4 wood screws (#8 x 1") per thimble.
  - c) Attach the 2 piece adjustable pipe section to the vent terminal and slide into position from the exterior. **The larger diameter end of the adjustable pipe goes to the vent terminal.**
  - d) Install the 90° elbow onto the adjustable pipe to determine the vertical centerline.
 

**Note: if the centerline cannot be met, the adjustable sections will have to be cut.**
  - e) Cut the 4 ft. section of rigid pipe to length. Attach the 45° elbow to the rigid pipe, and ensure that the pipe length when cut (with the 45° elbow) will seat onto both the starter collar and the 90° elbow. **Crimped section of rigid pipe seats into the 90° elbow. Only cut the uncrimped side of pipe.**
- Dismantle all pipe sections including vent terminal.

# INSTALLATION

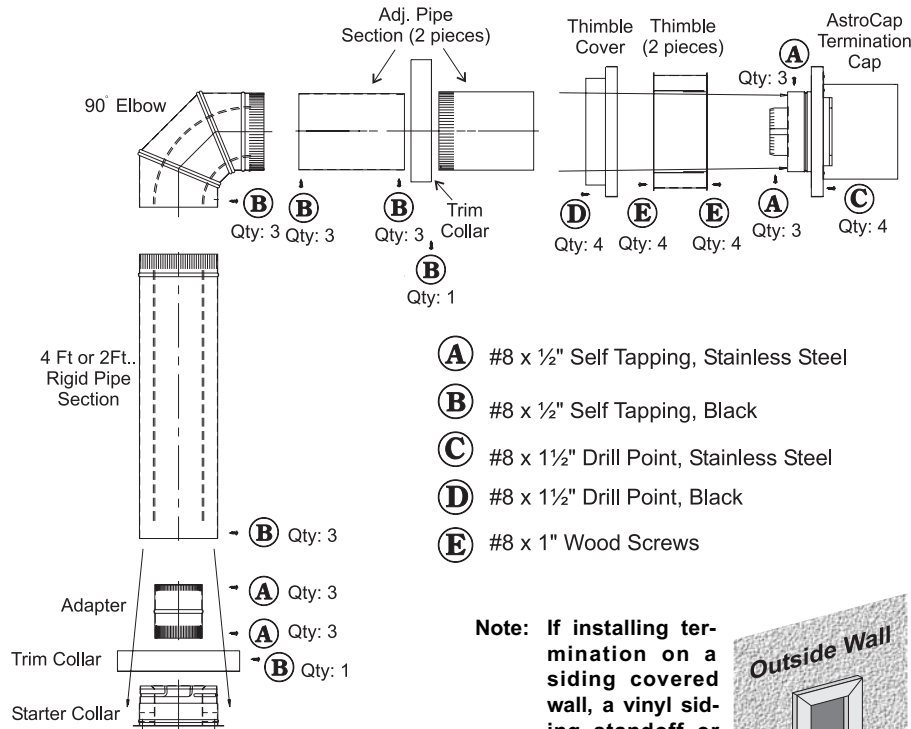

- (A)** #8 x 1/2" Self Tapping, Stainless Steel
- (B)** #8 x 1/2" Self Tapping, Black
- (C)** #8 x 1 1/2" Drill Point, Stainless Steel
- (D)** #8 x 1 1/2" Drill Point, Black
- (E)** #8 x 1" Wood Screws

**Note:** If installing termination on a siding covered wall, a vinyl siding standoff or furring strips must be used to ensure that the termination is not recessed into the siding. For vinyl siding standoff installation refer to the Dura-Vent Termination instructions.

- 3) Attach the 4" dia. flex liner to the vent terminal ensuring that the flex overlaps the collar of the vent terminal by a minimum of 1-3/8"(35mm). Use Mill-Pac to seal and secure with 3 of the #8 x 1/2" screws (stainless steel).
- 4) Attach the adjustable pipe section to the vent terminal using Mill-Pac and/or high temperature silicone and attach with 3 of the #8 x 1/2" screws (stainless steel).

**NOTE:** For best results and optimum performance with each approved venting system, it is highly recommended to apply "Mill-Pac" sealant (supplied) to every inner pipe connection. Failure to do so may result in drafting or performance issues not covered under warranty. Silicone (red RTV) is optional.

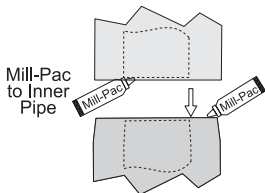

**Note:** The pipe seam should be facing down.

**Note:** To make the installation more aesthetically pleasing, we recommend framing out a square that the cap can be mounted on.

- 5) Slide the partially connected pipe and vent terminal assembly through the wall thimbles (from the exterior into the interior) and secure the cap to the exterior wall with 4 of the supplied screws (#8 x 1-1/2" drill point, stainless steel). Note: pilot holes will need to be drilled through the wall thimble on all 4 corners.

**Note:** The four screws provided for the vent cap should be replaced with appropriate fasteners for stucco, brick, concrete, or other types of sidings.

- 6) A bead of non-hardening mastic should be run around both the termination and vinyl siding standoff to prevent water from entering and to make a tight seal between the cap and the standoff.
- 7) Stretch the 4" dia. flex liner out fully and get a trial fit of the liner onto the 4" dia. starter collar.
- 8) Cut the 4" dia. flex liner to the desired size.

Hint: leave an extra 12" to 16" of length, this will make the final assembly easier to work with.

- 9) Secure the 4" dia. flex liner to the 4" adapter with Mill-Pac and 3 of the #8 x 1/2" screws (stainless steel).

- 10) Slide the decorative Thimble Cover over the pipe sections and secure with 4 screws (#8 x 1-1/2" drill point, black) to the wall.

- 11) Slide the 90° elbow (crimp end up), the 45° elbow and the 4 ft. pipe section (crimp end up) over the 4" dia. flex liner.

- 12) Install the spring spacers onto the pipe sections.

- 13) Secure the 4" dia. flex liner with adapter onto the stove collar. Put a bead of Mill-Pac around the appliance adapter and secure with 3 screws (#8 x 1/2, stainless steel).

- 14) Attach the 45° elbow onto the starter collar by sealing with Mill-Pac and/or high temperature silicone and securing with 3 of the #8 x 1/2" (black) screws.

- 15) Attach the pipe section to the 45° elbow by sealing with Mill-Pac and/or high temperature silicone and securing with 3 of the #8 x 1/2" screws (black). Pipe seams should be facing the wall.

- 16) Attach the 90° elbow onto the pipe section by sealing with Mill-Pac and/or high temperature silicone and securing with 3 of the #8 x 1/2" screws (black).

- 17) Slide the adjustable pipe section onto the 90° elbow. Slide the trim collar over the adjustable pipe sections to cover the joint of the telescopic section.) The flex may have to be compressed back in order for the adjustable pipe to properly mate to the elbow. Seal with Mill-Pac and/or high temperature silicone and secure with 3 of the #8 x 1/2" screws (black). Pipe seams facing down.

- 18) Install the trim collar over the starter collar and secure with a #8 x 1/2" screw (black).

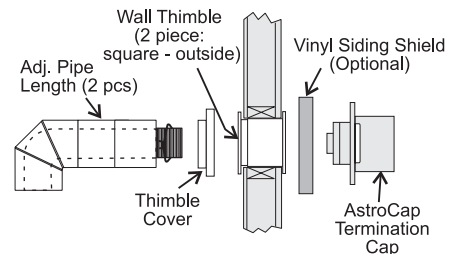

If the pipe needs to be touched up, use only Stove Brite High Temperature Metallic Black Stove Paint.



## DURA-VENT TERMINATION KIT

### Planning Your Dura-Vent Installation

There are two basic types of Dura-Vent Direct Vent System installations: horizontal termination and vertical termination. Confirm the maximum horizontal run and maximum vertical rise from the diagrams in the "Venting Arrangement" section.

When planning your installation, it will be necessary to select the proper length of vent pipe for your particular requirements. For horizontal installations, determine the minimum clearance from the rear of the unit to the wall. It is also important to note the wall thickness. (The wall

thimble is suitable for 2 x 4 or 2 x 6 wall construction.) Select the amount of vertical rise desired for "vertical-to-horizontal" type installations.

**Warning: Always maintain required clearances (air spaces) to nearby combustibles to prevent a fire hazard. Do not fill air spaces with insulation.**

The minimum clearance requirements between the outer wall of the vent pipe and nearby combustible surfaces is 1-1/4 inch. Be sure to check the vent termination clearance requirements from

decks, windows, soffits, gas regulators, air supply inlets and public walkways as specified in the "Exterior Vent Terminal Locations" section and in your local building codes.

To determine the length of vent pipe required for vertical installations, measure the distance from the unit flue outlet to the ceiling, the ceiling thickness, the vertical rise in an attic or second storey, and allow for sufficient vertical height above the roof line.

For multi-storey applications, fire stops are required at each floor level. If an offset is needed, additional pipe, elbows and supports will be required.

Do not exceed the maximum number of elbows. One 90° for horizontal terminations and two 45° for vertical termination.

### Dura-Vent Vertical Termination Installation

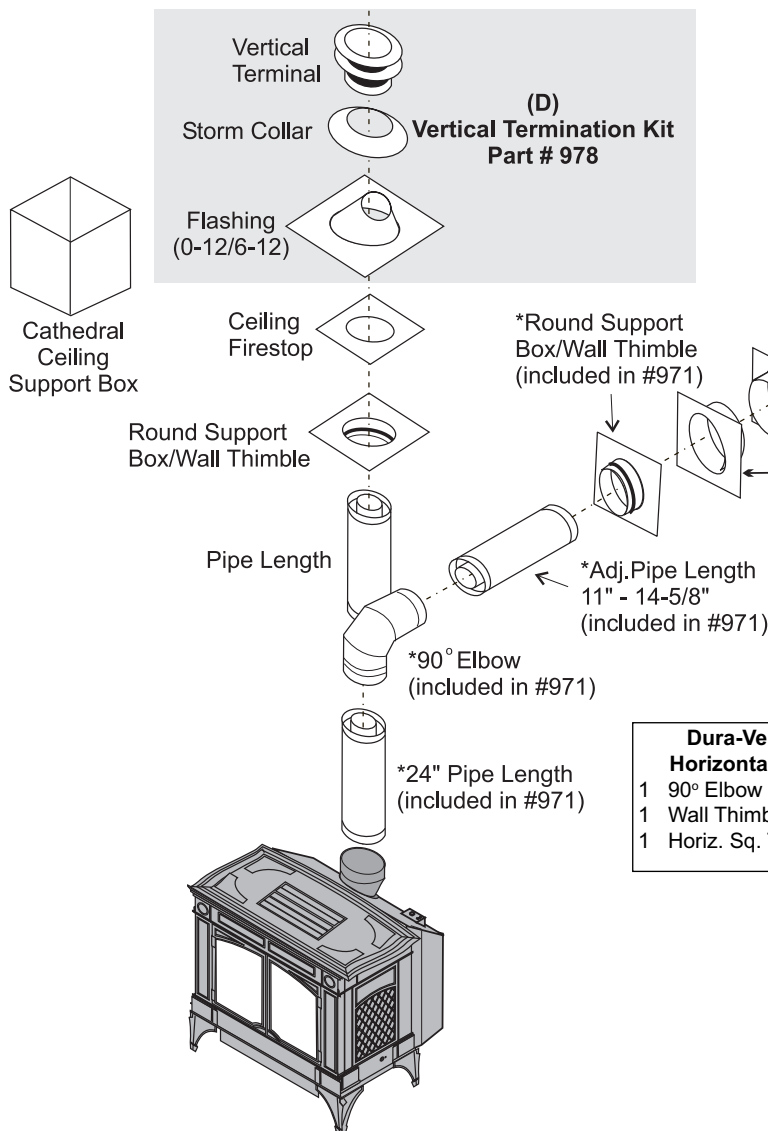

### Dura-Vent Horizontal Termination Installation

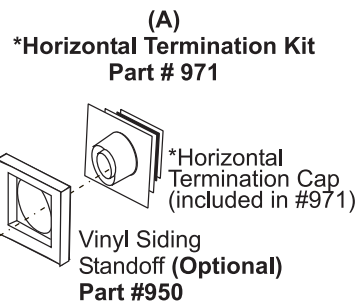

- Dura-Vent Basic Horizontal Kit # 970**
- 1 90° Elbow
  - 1 Wall Thimble Cover
  - 1 Horiz. Sq. Term. Cap

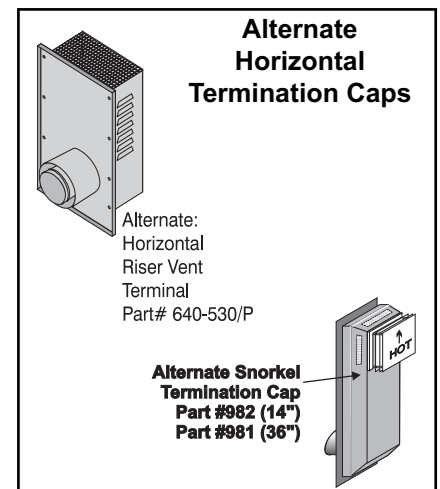

# INSTALLATION

## DURA-VENT HORIZONTAL INSTALLATIONS

- 1) Set the unit in its desired location. Check to determine if wall studs or roof rafters are in the way when the venting system is attached. If this is the case, you may want to adjust the location of the unit.
- 2) Direct Vent pipe and fittings are designed with special twist-lock connections to connect the venting system to the appliance flue outlet. A twist-lock appliance adapter is installed on the unit at the factory. Assemble the desired combination of pipe and elbows to the appliance adapter with pipe seams oriented towards the wall or ceiling, as much out of view as possible. The final positioning of the pipe and 90° elbow assembly is determined by the mounting orientation of the adapter on the stove and twist-locked for a solid connection.

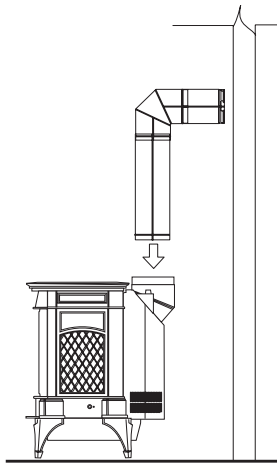
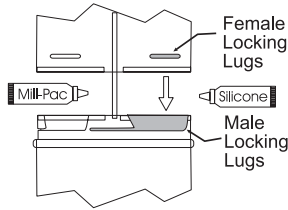

Diagram 1:  
Hint: Apply silicone to female end.



**NOTE: For best results and optimum performance with each approved venting system, it is highly recommended to apply "Mill-Pac" sealant (supplied) to every inner pipe connection. Failure to do so may result in drafting or performance issues not covered under warranty. Silicone (red RTV) is optional.**

b) Horizontal runs of vent must be supported every three feet. Wall straps are available for this purpose.

**c) Snorkel Terminations:**

For installations requiring a vertical rise on the exterior of the building, 14-inch and 36-inch tall Snorkel Terminations and the Riser Vent as shown in Diagrams 2 & 2a are available. Follow the same installation procedures as used for standard Horizontal Termination. NEVER install the snorkel upside down.

\*As specified in CGA B149 Installation Code. Local codes or regulations may require different clearances.

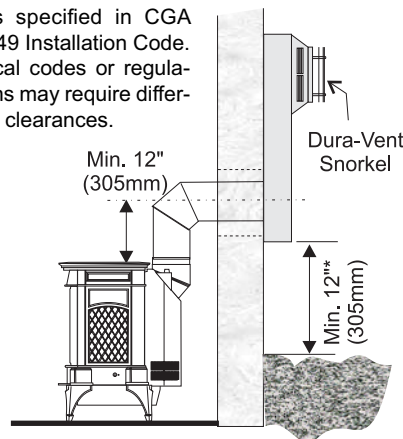

Diagram 2

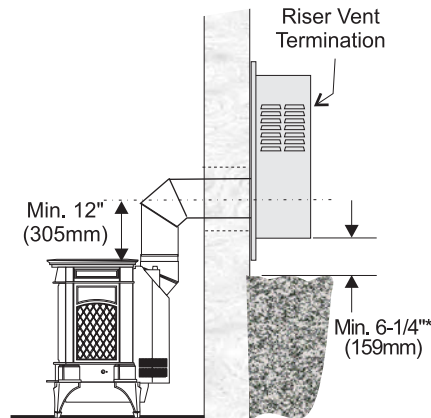

Diagram 2a

### Below Grade Snorkel Installation

If the Snorkel Termination must be installed below grade, i.e. basement application, proper drainage must be provided to prevent water from entering the Snorkel Termination. Refer to Dura-Vent Installation instructions for details. Do not attempt to enclose the Snorkel within the wall, or any other type of enclosure.

- 3) With the pipe attached to the stove, slide the stove into its correct location, and mark the wall for a 10" x 10" (inside dimensions) square hole. The center of the square hole should line up with the centerline of the horizontal pipe, as shown in diagram 3. Cut and frame the 10 inch square hole in the exterior wall where the vent will be terminated. If the wall being penetrated is constructed of non-combustible material, i.e. masonry block or concrete, a 7" diameter hole is acceptable.

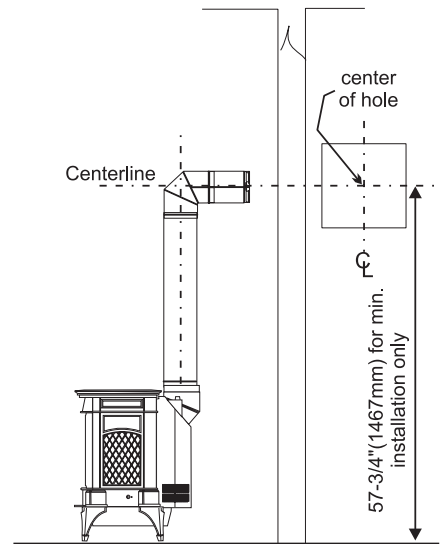

Diagram 3

**Note:**

- a) Twist-lock procedure: Four indentations, located on the female ends of pipes and fittings, are designed to slide straight onto the male ends of adjacent pipes and fittings, by orienting the four pipe indentations so they match and slide in to the four entry slots on the male ends (Diagram 1). Push the pipe sections completely together, then twist-lock one section clockwise approximately one-quarter turn, until the two sections are fully locked. The female locking lugs will not be visible from the outside on the Black Pipe or fittings. They may be located by examining the inside of the female ends.

**Note:**

- a) The horizontal run of vent should have a 1/4 inch rise for every 1 foot of run towards the termination. Never allow the vent to run downward. This could cause high temperatures and may present the possibility of a fire.
  - b) The location of the horizontal vent termination on an exterior wall must meet all local and national building codes, and must not be blocked or obstructed. See diagram in the "External Vent Terminal Locations" section.
- 4) If installing the vent termination to a wall with vinyl siding, the Vinyl Siding Standoff must be used. Attach the Vinyl Siding Standoff to the Horizontal Vent Termination, but first run a bead of non-hardening mastic around its outside edges, so as to make a seal between vent cap and the standoff. Install the Vinyl Siding Standoff (Part # 950) between the vent cap and the exterior wall and attach with the four wood screws provided. Seal around the Vinyl Siding Standoff on all four sides. Diagram 6. **The arrow on the vent cap should be pointing up.** Insure that the 1-1/4" clearances to combustible materials are maintained. See diagram 4.

**Note: If installing termination on a siding covered wall, a vinyl siding standoff or furring strips must be used to ensure that the termination is not recessed into the siding. The four wood screws provided should be replaced with appropriate fasteners for stucco, brick, concrete, or other types of sidings.**

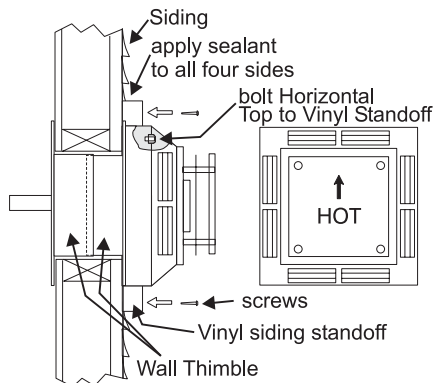

Diagram 4

- 5) Before connecting the horizontal run of vent pipe to the vent termination, slide the black decorative wall thimble cover over the vent pipe, then slide the Wall Thimble (Part #942) over the vent pipe.
- 6) Slide the appliance and vent assembly towards the wall carefully inserting the vent pipe into the vent cap assembly. It is important that the vent pipe extends into the vent cap a sufficient distance so as to result in a minimum pipe overlap of 1-1/4 inches. Secure the connection between the vent pipe and the vent cap by attaching the two sheet metal strips extending from the vent cap assembly into the outer wall of the vent pipe. Use the two sheet metal screws provided to connect the strips to the pipe. Bend any remaining portion of the sheet metal strip back towards the vent cap, so it will be concealed by the decorative wall thimble cover. See Diagram 5.

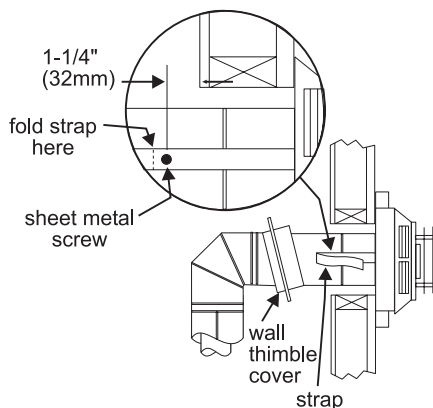

Diagram 5

- 7) Install wall thimble in the center of the 10" square and attach with wood screws.
- 8) Slide the decorative wall thimble up to the wall surface being careful not to scratch the paint and attach with screws provided. Apply decorative brass or chrome trim if desired. See Diagram 6.

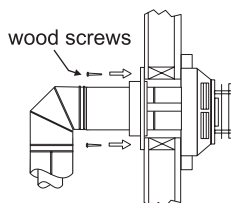

Diagram 6

## DURA-VENT VERTICAL TERMINATION

- 1) Maintain the 1-1/4" clearances (air spaces) to combustibles when passing through ceilings, walls, roofs, enclosures, attic rafter, or other nearby combustible surfaces. Do not pack air spaces with insulation. Check the "Exterior Vent Terminal Locations" section for the maximum vertical rise of the venting system and the maximum horizontal offset limitations.

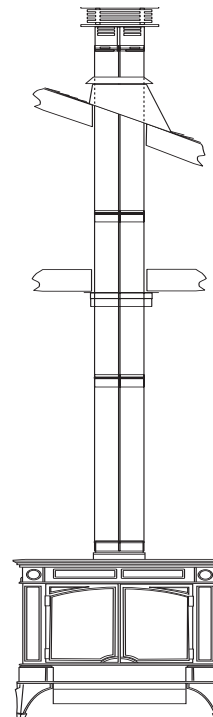

Diagram 7

- 2) Set the gas appliance in its desired location. Drop a plumb bob down from the ceiling to the position of the appliance flue exit, and mark the location where the vent will penetrate the ceiling. Drill a small hole at this point. Next, drop a plumb bob from the roof to the hole previously drilled in the ceiling, and mark the spot where the vent will penetrate the roof. Determine if ceiling joists, roof rafters or other framing will obstruct the venting system. You may wish to relocate the appliance or to offset, as shown in Diagram 8 to avoid cutting load bearing members.

# INSTALLATION

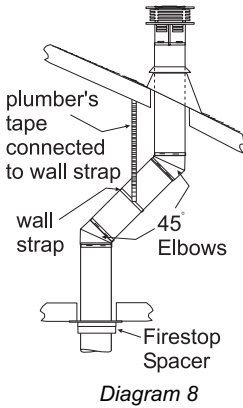

Diagram 8

- 3) To install the Round Support Box/Wall Thimble in a flat ceiling, cut a 10 inch square hole in the ceiling centred on the hole drilled in Step 2. Frame the hole as shown in Diagram 9.

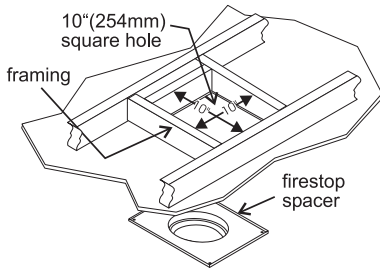
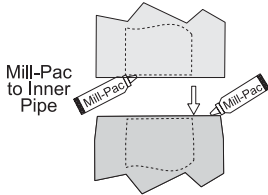

Diagram 9

- 4) Assemble the desired lengths of black pipe and elbows necessary to reach from the appliance adapter up through the Round Support Box. Insure that all pipes and elbow connections are in the fully twist-locked position and sealed.



**NOTE: For best results and optimum performance with each approved venting system, it is highly recommended to apply "Mill-Pac" sealant (supplied to every inner pipe connection. Failure to do so may result in drafting or performance issues not covered under warranty. Silicone (red RTV) is optional.**

- 5) Cut a hole in the roof centred on the small drilled hole placed in the roof in Step 2. The hole should be of sufficient size to meet the minimum requirements for clearance to combustibles of 1-1/4". Slip the flashing under the shingles (shingles should overlap half the flashing) as per Diagram 10.

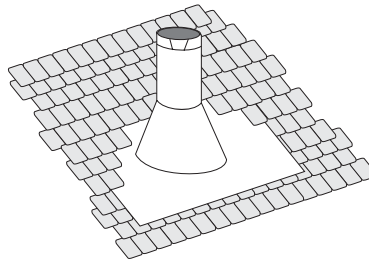

Diagram 10: The upper half of the flashing is installed under the roofing material and not nailed down until the chimney is installed. This allows for small adjustments.

- 6) Continue to assemble pipe lengths.

**Note: If an offset is necessary in the attic to avoid obstructions, it is important to support the vent pipe every 3 feet, to avoid excessive stress on the elbows, and possible separation. Wall straps are available for this purpose. See Diagram 5.**

Galvanized pipe and elbows may be utilized in the attic as well as above the roofline. The galvanized finish is desirable above the roofline due to its higher corrosion resistance.

Continue to add pipe sections through the flashing until the height of the vent cap meets the minimum height requirements specified in Diagram 11 or local codes. Note that for steep roof pitches, the vertical height must be increased. A poor draft, or down drafting can result from high wind conditions near big trees or adjoining roof lines, in these cases, increasing the vent height may solve the problem.

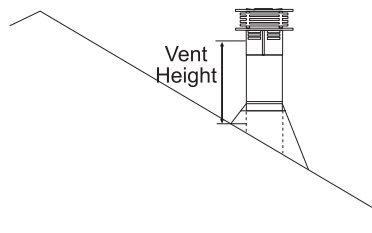

Diagram 11

Roof Pitch	Minimum Vent Height	
	Feet	Meters
flat to 7/12	2	0.61
over 7/12 to 8/12	2	0.61
over 8/12 to 9/12	2	0.61
over 9/12 to 10/12	2.5	0.76
over 10/12 to 11/12	3.25	0.99
over 11/12 to 12/12	4	1.22
over 12/12 to 14/12	5	1.52
over 14/12 to 16/12	6	1.83
over 16/12 to 18/12	7	2.13
over 18/12 to 20/12	7.5	2.29
over 20/12 to 21/12	8	2.44

- 7) Ensure vent is vertical and secure the base of the flashing to the roof with roofing nails, slide storm collar over the pipe section and seal with a mastic.
- 8) Install the vertical termination cap by twist locking it.

**Notes:**

- a) For multistorey vertical installations, a Ceiling Fire stop (Part # 963) is required at the second floor, and any subsequent floor. Diagram 12. The opening should be framed to 10 " x 10" inside dimensions, in the same manner as shown in Diagram 9.
- b) Any occupied areas above the first floor, including closets and storage spaces, through which the vertical vent passes, must be enclosed.

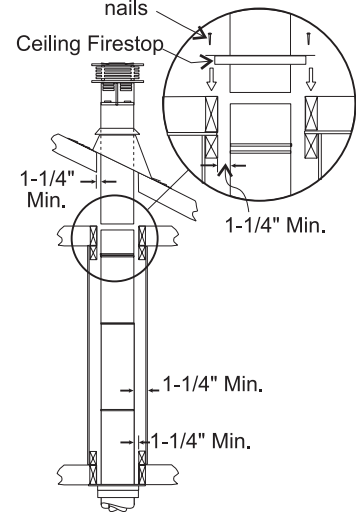
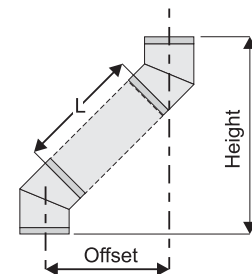

Diagram 12

**Offset Chart**

GS 6"(152mm) Nominal Diameter ID					
Offset	Pipe Length (L)		Height		
	inches	mm	inches	mm	
4 3/4	121	0	0	13 1/4	337
9	229	6	152	17 1/2	445
11 1/4	286	9	229	19 1/2	495
13 1/4	337	12	305	21 3/4	552
21 3/4	552	24	610	30 1/4	768
30 1/4	768	36	914	39	991
38	965	48	1219	47	1194



## CONVERTING CLASS-A METAL CHIMNEY OR MASONRY CHIMNEY TO DIRECT VENT SYSTEM

There are two different types of direct vent conversion systems listed below. Follow the appropriate directions for your installation.

A) Through an existing factory built metal chimney going through the ceiling: A typical conversion of this type is shown in diagram 1. The concept of direct vent conversion is to connect an adaptor to an Underwriters Laboratories (UL) listed 4 inch diameter aluminum flex pipe which is then passed down through the center of the existing metal chimney system. Three sizes of Top Adaptors are available from Simpson Dura-Vent. The Retro Connector (909B) is attached to the bottom of the flex pipe. The Top Adaptor and the Retro Connector are attached to the existing chimney with sheet metal screws. The appliance is then connected to the chimney with appropriate black direct vent pipe and an adjustable length section.

B) Through the wall of an existing masonry chimney: A typical conversion of an existing masonry chimney is shown in Diagram 6. A Top Adaptor (985K) and Flashing are used at the top of the masonry chimney. The 4 inch aluminum liner is connected to the adaptor and is passed down the chimney and out through the masonry wall and attached to the Retro Connector (909B). The Retro Connector is attached to the masonry wall and then connected to the direct vent pipe leading to the appliance.

**Prior to installation and connection of the vent system to a factory-built or masonry chimney, the chimney must be inspected and thoroughly cleaned by a qualified service person, such as a certified chimney sweep or home inspection service.**

**The direct vent system must not be connected to a damaged factory-built or masonry chimney.**

**For factory built, zero clearance, and masonry chimneys cleanout doors and caps or plugs for cleanout tee fittings and ash dumps shall be secured in place and sealed before installing a Direct Vent system within the chimney.**

**If the appliance shuts off during operation, contact a qualified service person to determine if a negative pressure and/or leaky chimney condition exists. Do not operate the appliance until the problem is corrected.**

**Approved for US Installations Only**  
 The use of an existing chimney as an air intake is not covered under the ANSI Z21.88b-1999, CSA 2.33b-M99 test methods and the resulting ITS/WHI product certification. The code Authority Having Jurisdiction must be consulted prior to proceeding with this installation method.

### Converting a Factory Built Metal Chimney

- 1) Remove the existing chimney cap.
- 2) Measure the distance from the top end of the chimney to the bottom of the ceiling support box, add 3" (76mm) to this measurement, and cut a section of the 4" (102mm) flex pipe to that length (the flex should already be extended to its nominal length).

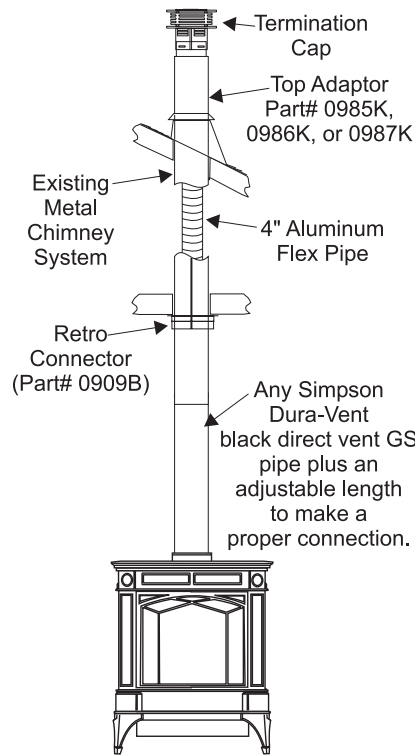

Diagram 1

- 3) Connect the end of the flex pipe section to the underside of the Top Adaptor using 3 sheet metal screws (refer to Diagram 2).

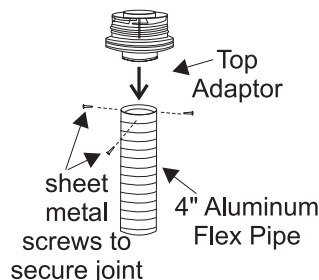

Diagram 2

- 4) Pass the flex pipe down through the center of the chimney system, and center the adaptor on the top of the chimney pipe. Drill four 1/8" diameter holes through the adaptor and into the chimney top. Insure that you are in fact, drilling into the metal on the chimney. Twist-lock the Termination Cap (Part# 980 or 991) onto the Adaptor (refer to Diagrams 3 and 4).

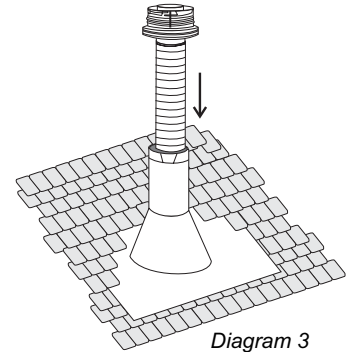

Diagram 3

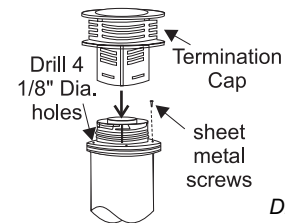

Diagram 4

- 5) Pull the flex pipe down through the ceiling support box, until it protrudes approximately 3" (76mm). Connect the flex pipe to the Retro Connector by slipping it into the 4-3/4" (121mm) diameter sleeve on the top side of the Connector. Use 3 sheet metal screws to assemble these two parts.
- 6) Push the flex pipe back up into the ceiling support box, center the Retro Connector, and attach it to the support box, or decorative sleeve for double wall solid packed pipe, with the sheet metal screws (supplied). The holes in the Retro Connector are pre-punched (refer to Diagram 5).

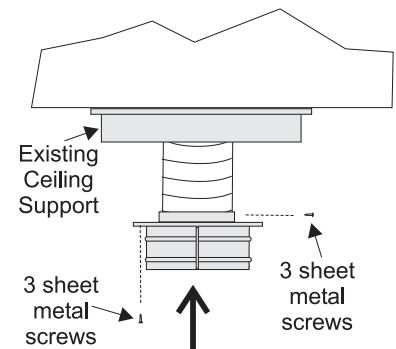

Diagram 5

- 7) The connection between the appliance and the Retro Connector may be completed with sections of black direct vent pipe, together with an adjustable length.



# INSTALLATION

## CATHEDRAL CEILINGS

### Round Support (RDS) & Square Support (SQS)

If your home has a cathedral ceiling (no attic space between the ceiling and the roof), install the chimney and support as follows.

- 1) Situate the chimney in a convenient location as near as possible to the appliance outlet. Cut and frame a hole in the roof for the support. The sides of this hole must be vertical with 1 1/4" (32mm) clearance.
- 2) Place the support in the opening. Lower it to the correct height as determined by the table and diagram below.

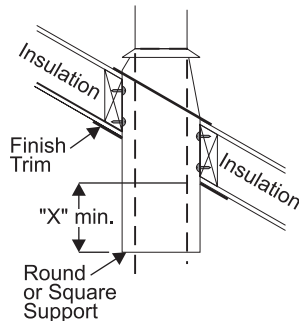

Slope	"X"
0/12 - 2/12	4"
2/12 - 7/12	5-1/2"
7/12 - 12/12	6-3/4"
12/12 - 24/12	7-1/2"
24/12+	12-1/2"

Using a level, make sure the support is vertical. If the support extends above the roof, cut it flush with the top of the roof. Nail the support to the frame opening using (8) 3" spiral nails or #8 x 1-1/2" screws.

**Note: If you are using a 6" square support you may find it difficult to screw it in place because it is fairly small inside.**

Simpson Dura-Vent has provided angle brackets with this support which can be screwed to the outside of the support box and nailed to surrounding framing as required. Use a minimum of four #8 x 1/2" screws per bracket. In some cases these brackets may need to be trimmed (e.g.: to fit under a flashing). Place the Finish Collar around the support and fasten it to the ceiling using the screws provided.

- 3) Use appropriate roof flashing. Place the flashing under the upper shingles and on top of the lower shingles approximately half of the flashing should be under the shingles.

- 4) Assemble the desired lengths of Black Pipe and Elbows necessary to reach from the appliance adapter up through the support box and flashing to proper height as per Diagram 12, local codes or the "Exterior Vent Terminal Locations" section. Ensure that all pipe and elbow connections are in their fully twist lock position.
- 5) Ensure vent is vertical and secure flashing to the roof with roofing nails. Slide the storm collar over the pipe section and seal with a mastic.
- 6) Twist lock the vent cap on to the last section.

### Support Extensions - Round (RDSE) or Square (SQSE)

Steep pitched cathedral ceilings may require the use of a support extension. This piece fits down inside the support and can be adjusted to increase the support's length by up to 22" (559mm). The extension is attached to the support using the eight metal screws provided. Be sure there is at least a 2" (51mm) overlap where the extension joins the support.

## HIGH ELEVATION

This unit is approved in Canada for altitude to 4500 ft. (CAN/CGA-2.17-M91). For Natural Gas installations above 4500 ft. follow current CAN/CGA-B149.1.

## GAS CONNECTION

The gas connection is a 3/8" NPT 90° elbow. The gas line can be rigid pipe or to make installation easier, use a listed flexible connector and/or copper tubing if allowed by local codes. Since some municipalities have additional local codes it is always best to consult with your local authorities and the CAN/CGA B149 installation codes.

For USA installations follow local codes and/or the current National Fuel Gas Code, ANSI Z223.1.

When using copper or flex connectors use only approved fittings. Always provide a union so that gas lines can be easily disconnected for burner and/or valve servicing. Flare nuts for copper lines and flex connectors are usually considered to meet this requirement.

**IMPORTANT: ALWAYS CHECK FOR GAS LEAKS WITH A SOAP AND WATER SOLUTION OR GAS LEAK DETECTOR. DO NOT USE OPEN FLAME FOR LEAK TESTING.**

**Note: Prior to any pressure testing of the gas supply piping system that exceeds test pressures of 1/2 psig, this appliance must be disconnected from the piping system. If test pressures equal to or less than 1/2 psig are used then this appliance must be isolated from the piping system by closing its individual manual shut-off valve during the testing.**

### SYSTEM DATA - H35 For 0 to 4500 feet altitude

#### Natural Gas

Max. Input Rating 36,000 Btu/h  
Min. Input Rating 18,000 Btu/h  
Orifice Size #33 DMS

#### Convertible to:

Max. Input Rating 30,000 Btu/h  
Min. Input Rating 14,300 Btu/h  
Orifice Size #37 DMS

#### Propane

Max. Input Rating 34,000 Btu/h  
Min. Input Rating 17,500 Btu/h  
Orifice Size #51 DMS

#### Convertible to:

Max. Input Rating 28,500 Btu/h  
Min. Input Rating 15,000 Btu/h  
Orifice Size #52 DMS

#### Supply Pressure

Natural Gas min. 5.0" w.c.  
Propane min. 12.0" w.c.

#### Manifold Pressure

Natural Gas 3.8" +/- 0.2" w.c.  
Propane 11" +/- 0.2" w.c.



## AERATION ADJUSTMENT

The burner aeration is factory set but may need adjusting due to either the local gas supply, air supply or altitude.

<b>Natural Gas</b>	<b>1/4" (6.4 mm)</b>
<b>Propane</b>	<b>3/8" (9.5 mm)</b>

The aeration adjustment gears are located on the right side of the burner box. Remove the Hampton® Logo plate on the right side of the unit to access the adjustment gears.

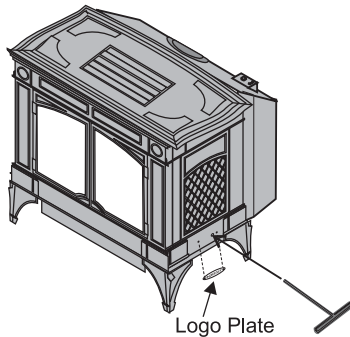

To adjust the aeration: use the allen key to turn the turning gear which will adjust the air shutter. Open the air shutter for a blue flame or close it for a yellower flame.

**Closed - Tall yellow flame**  
**Open - Short blue flame**

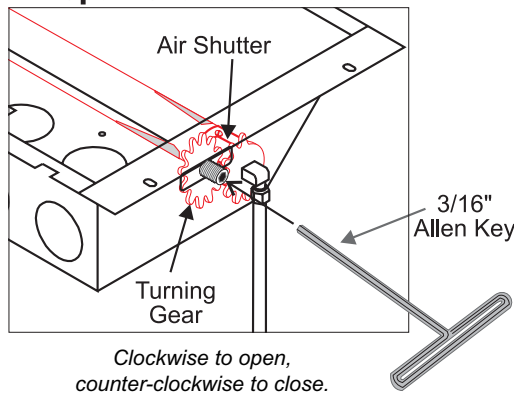

**Caution:** Carbon will be produced if the air shutter is closed too much.

**Note:** Any damage due to carboning resulting from improperly setting the aeration controls is NOT covered under warranty.

**Note:** Aeration Adjustment should only be performed by an authorized Hampton® Installer at the time of installation or service.

## GAS PIPE PRESSURE TESTING

The appliance must be isolated from the gas supply piping system by closing its individual manual shut-off valve during any pressure testing of the gas supply piping system at test pressures equal to or less than 1/2 psig. (3.45 kPa). Disconnect piping from valve at pressures over 1/2 psig.

The manifold pressure is controlled by a regulator built into the gas control, and should be checked at the pressure test point.

**Note:** To properly check gas pressure, both inlet and manifold pressures should be checked using the valve pressure ports on the valve.

- 1) Make sure the valve is in the "OFF" position.
- 2) Loosen the "IN" and/or "OUT" pressure tap(s), turning counterclockwise with a 1/8" wide flat screwdriver.
- 3) Attach manometer to "IN" and/or "OUT" pressure tap(s) using a 5/16" ID hose.
- 4) Light the pilot and turn the valve to "ON" position. Read manometer.

- 5) The pressure check should be carried out with the unit burning and the setting should be within the limits specified on the safety label.
- 6) When finished reading manometer, turn off the gas valve, disconnect the hose and tighten the screw (clockwise) with a 1/8" flat screwdriver. **Note: Screw should be snug, but not overtightened.**

### Valve Description

- 1) Gas on/off knob
- 2) Manual high/low adjustment
- 3) Pilot Adjustment
- 4) Thermocouple Connection
- 5) Main Operator
- 6) Outlet Pressure Tap (Manifold Pressure)
- 7) Inlet Pressure Tap (Supply Pressure)
- 8) Pilot Outlet
- 9) Main Gas Outlet
- 10) Flange Securing Screw Holes
- 11) Alternative TC Connection Point
- 12) Thermoelectric Unit
- 13) Additional Valve Mounting Hole

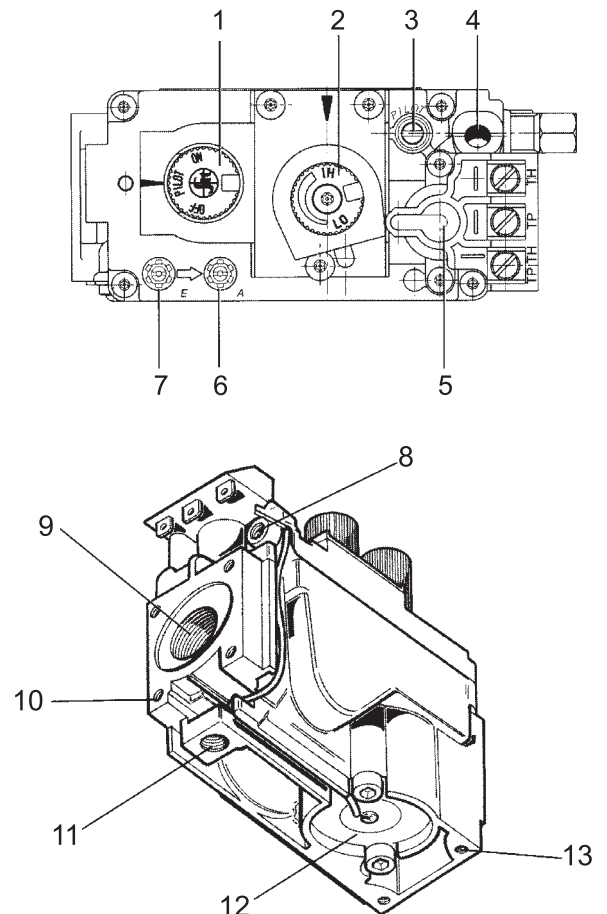

# INSTALLATION

## CONVERSION KIT #791-969 FROM NG TO LP

**THIS CONVERSION MUST BE DONE BY A QUALIFIED GAS FITTER  
IF IN DOUBT DO NOT DO THIS CONVERSION !!**

### Each Kit contains one LPG Conversion Kit and one DC Sparker Kit.

#### LPG Conversion Kit Contains:

Qty.	Part #	Description
1	904-529	5/32" Allen Key
1	904-645	Burner Orifice #51
1	918-590	Label "Converted to LPG"
1	908-528	Red "LPG" label
1	910-037	LP Injector (Pilot Orifice)
1	918-487	Instruction Sheet

#### DC Sparker Kit Contains:

Qty.	Part #	Description
1	820-475	Bracket DC Sparker
1	820-476	Bracket DC Sparker
1	904-153	Washer #8 External Star
1	904-330	Nut 8-32 Hex
1	904-438	Plug Nylon 0.750 Hole, Black (for H35 only)
1	904-531	Bushing Split Plastic 0.500 in.
1	904-543	Screw 8-32 x 3/4 Pan Head
2	904-553	Screw #8 x 1/2 Type "B", Black Oxide
1	910-073	Spark Generator Battery Holder
1	910-074	Spark Generator Switch C/W Wire
1	910-078	Battery Size AA Energizer En91
2	910-199	Clip Wire Holder
1	910-903	Wire Fan To Power Cord Ground 30 in.
	904-781	Velcro Hook, Black
	904-782	Velcro Hook, Black

- 4) Remove the 2 screws holding the Burner Assembly to the firebox base. Push the Burner Assembly to the left and lift out.



Remove the 2 screws, push Burner Assembly to the left and lift out.

- 5) Pull off the pilot cap to expose the pilot orifice.



- 6) Unscrew the pilot orifice with the allen key and replace with the LP pilot orifice in the kit and replace pilot cap.

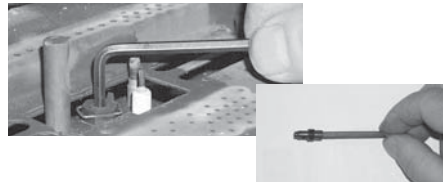

- 7) Remove burner orifice with a 1/2" wrench and discard. Use another wrench to hold on to the elbow behind the orifice.

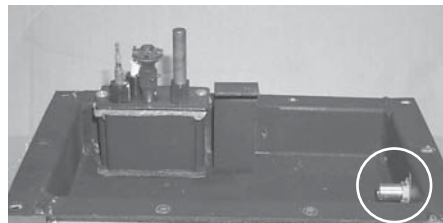

Burner Orifice

- 8) Reinstall new burner orifice LP stamped #51 and tighten.

- 9) Turn control knob to the "OFF" position.

- 10) Remove the black protection cap by hand from the high-low knob (Fig.1).



Fig.1

- 11) Insert a 5/32" or 4mm Allen wrench into the hexagonal key-way of the screw (Fig. 2), rotate it counter-clockwise until it is free and extract it.



Fig.2

- 12) Check that the screw is clean and if necessary remove dirt.

- 13) Flip the screw (Fig. 3).

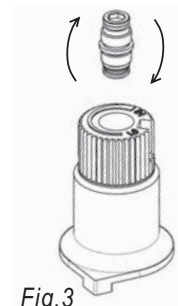

Fig.3

### Installation of LPG Conversion Kit:

- 1) Shut off the gas supply.
- 2) **H35-1:** Lift off the Cast Top and remove the glass front. Also, open up the control panel door.  
**P90-1:** Remove the facade if it is installed. Remove the glass door (refer to the glass door section in the manual).
- 3) Remove the logs, embers, and brick panels (if used).

- 14) Using the Allen wrench as shown in Fig.4, rotate the screw clockwise until snug, do not overtighten.

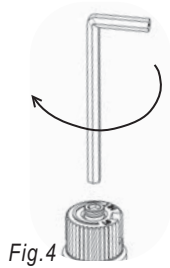

Fig.4

**WARNING!**  
Do not overtighten the screw.  
Recommended to grip the wrench by the short side.

- 15) Verify that if the conversion is from NG to LPG, the screw must be reassembled with the red o-ring visible (Fig. 5).

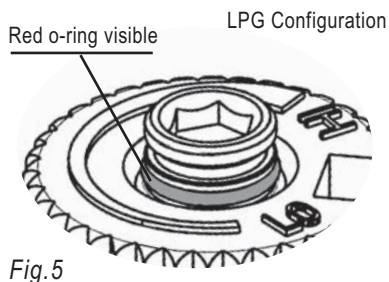

Fig.5

- 16) Reassemble the black protection cap (Fig. 6).

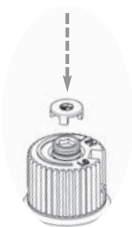

Fig.6

**WARNING!**  
Also check that the pilot and main burner injectors are appropriate for the gas type.

- 17) Reverse steps 4) to 2).
- 18) Attach clear label "This unit has been converted to LPG" near or on top of the serial # decal.
- 19) Replace yellow "Natural Gas" label with red "LPG" label.

## Installation of the DC Sparker for the H35-1 Units Only:

- 1) Remove the control panel by unscrewing the 2 screws.



- 2) First, remove the Piezo Ignition Wire from the Piezo Ignitor. Then remove the Piezo Ignitor from the control panel.

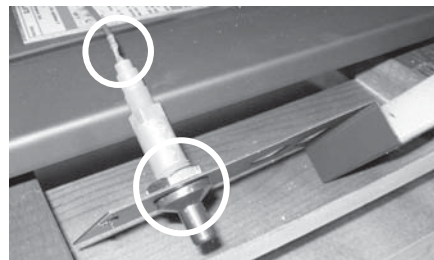

- 3) Plug up the Piezo hole with the plastic bushing.



- 4) Attach the DC sparker generator connector to the valve with a screw.

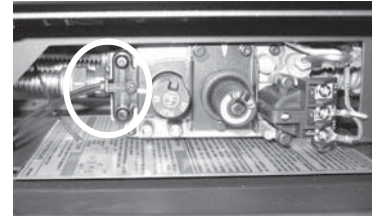
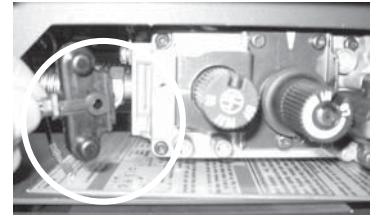

- 5) Remove the stove's rear panel by unscrewing the two screws.

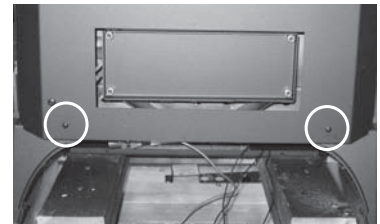

- 6) Attach the ground wire to the grounding stud.

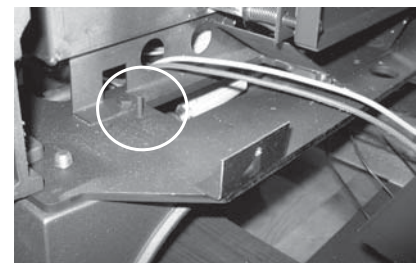

Before

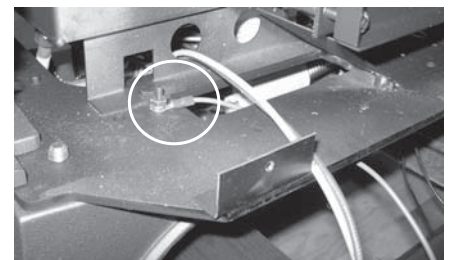

After



# INSTALLATION

- 7) Attach the Piezo ignition wire to the DC Sparker.

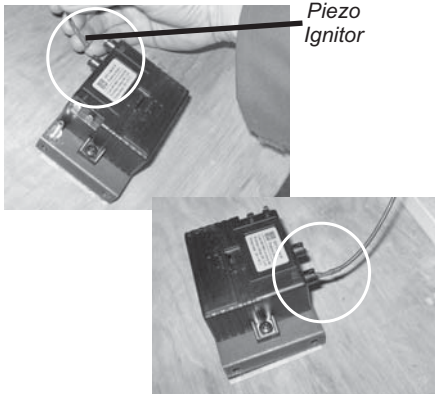

- 8) Insert both the ground wire and the DC sparker generator wire through the hole of the DC spark heat shield.

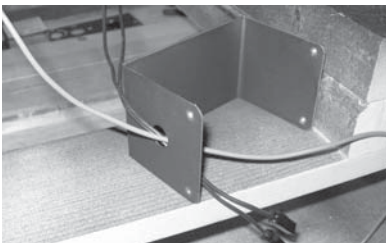

- 9) Install the plastic bushing over the outside of the hole.

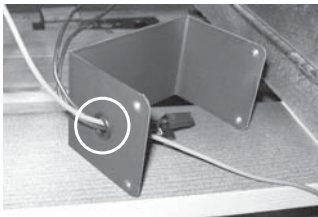

- 10) Attach the ground wire to the DC spark mounting bracket.



- 11) Attach the DC sparker generator wires to the DC sparker.

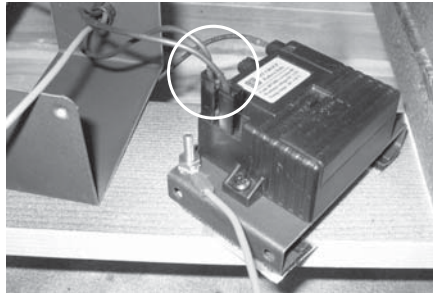

- 12) Install the supplied battery into the DC Sparker Box by opening the battery compartment.

**NOTE:** The battery in the DC Sparker Box will need to be replaced annually.

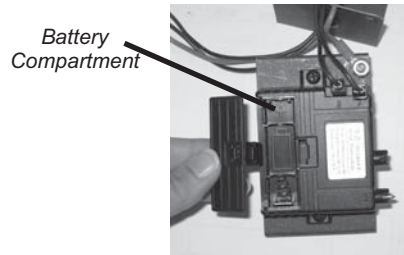

- 13) Attach the heat shield to the DC sparker, then mount this onto the stove.

**Note:** We recommend attaching the DC sparker box to the bottom rear of the stove (or place this in a convenient location, away from the heat source).

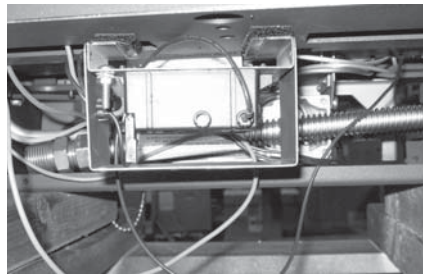

- 14) Tie up the loose wire with the wire clip.

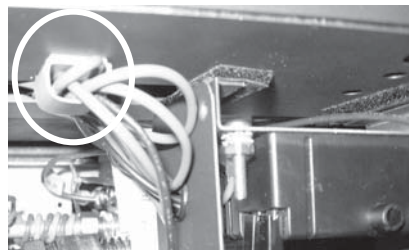

## Installation of the DC Sparker for the P90 Units Only:

- 1) Locate the Piezo Ignitor situated at the side of valve.

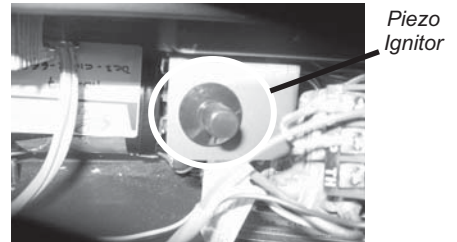

- 2) Remove the Piezo Ignitor by unscrewing the nut at the back of the mounting bracket.

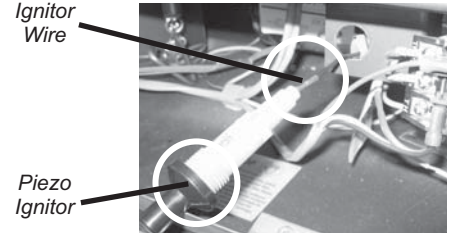

- 3) Disconnect the ignitor wire from the Piezo Ignitor and connect it to the DC Sparker.

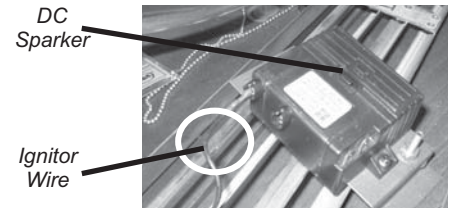

- 4) Connect the DC spark generator wires to the SIT Valve with the screw, which is provided in the kit.

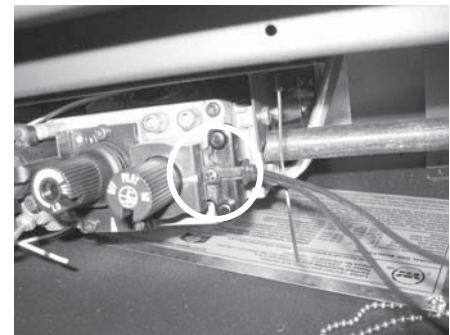

# INSTALLATION

- 5) Locate the ground lug at the receptical box, left of the unit.

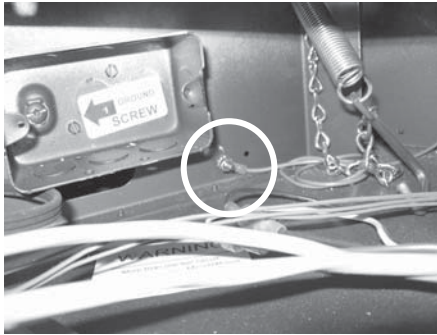

- 6) Connect one end of the supplied green ground wire to the lug with the nut and washer from the kit.

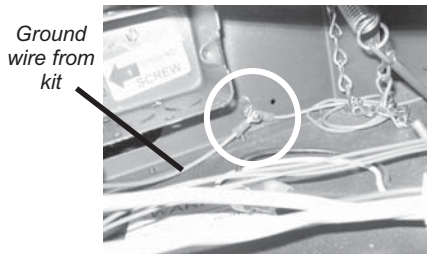

- 7) Install the 1/2" bushing to the heat shield.

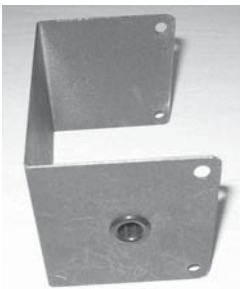

- 8) Run the other end of the ground wire and DC spark generator wires through the bushing on the heat shield.

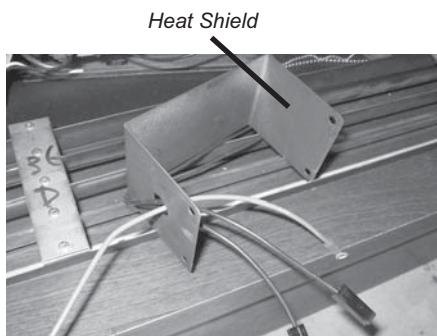

- 9) Plug the DC spark generator wires to the DC Sparker.



- 10) Connect the ground wire to the DC Sparker mounting bracket.

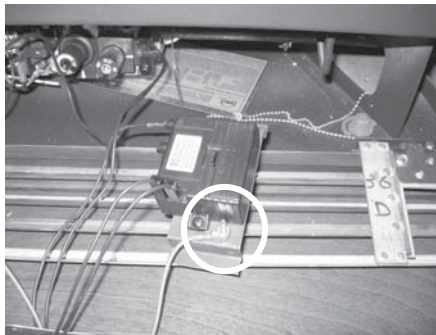

- 11) Install the supplied battery into the DC Sparker Box by opening the battery compartment.

**NOTE:** The battery in the DC Sparker Box will need to be replaced annually.

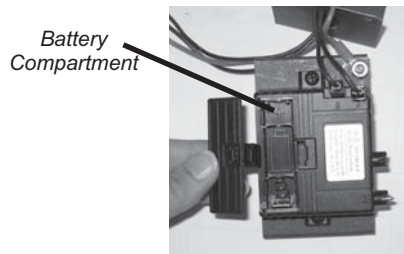

- 12) Mount the heat shield to the DC Sparker. Secure into place with the velcro, which is provided in the kit.

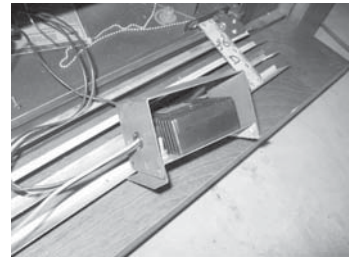

- 13) Find a location which is not too hot and is easy to reach for changing the battery.

- 14) Tie up the loose wire with the wire clip.

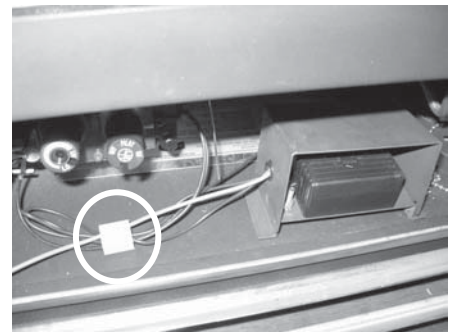

- 15) Check for gas leaks.

- 16) Check inlet and outlet pressures.

- 17) Check operation of flame control.

- 18) Check for proper flame appearance and glow on logs.

**Installer Notice:**  
These instructions must be left with the appliance.

# INSTALLATION

## CONVERSION KIT TO LOWER BTU RATING NATURAL GAS - KIT #: 740-950 PROPANE - KIT # 740-952

**THIS CONVERSION MUST BE DONE BY A QUALIFIED GAS FITTER  
IF IN DOUBT DO NOT DO THIS CONVERSION !!**

### Natural Gas Conversion Kit 740-950 Contains:

Qty.	Part #	Description
1	904-240	Burner Orifice #37 (Natural Gas)
1	918-034	Decal "Converted to 30,000 Btu"
1	918-148	Instruction Sheet

### Propane Conversion Kit 740-952 Contains:

Qty.	Part #	Description
1	904-390	Burner Orifice #52 (Propane)
1	918-149	Decal "Converted to 28,500 Btu"
1	918-148	Instruction Sheet

- 1) Shut off the gas supply.
- 2) Open the front door. Carefully remove the logs and lava rock. (Refer to manual for more detailed instructions.)
- 3) Remove burner by removing 2 screws, sliding the burner to the left and lift out. See diagram below.

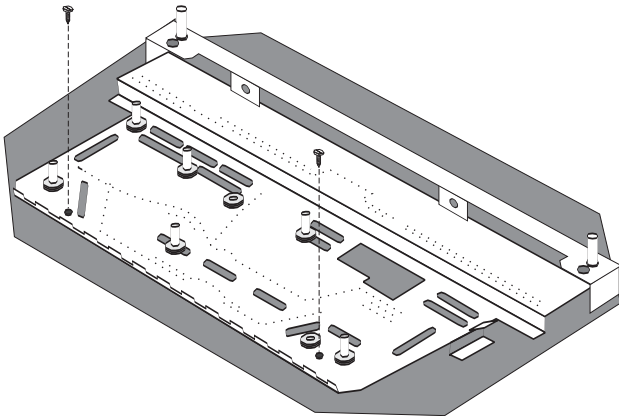

**Note:** Use a magnetic type screwdriver if possible.

- 4) Remove Rear Log Bracket by removing 2 screws. See diagram below.

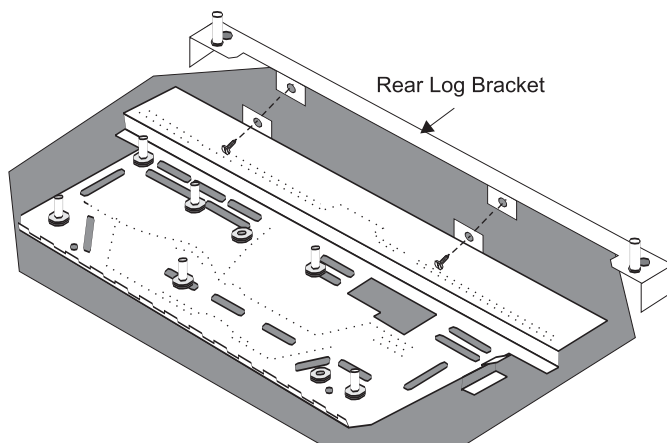

- 5) Unscrew the 2 Rear Log Pins and move to the front hole position.

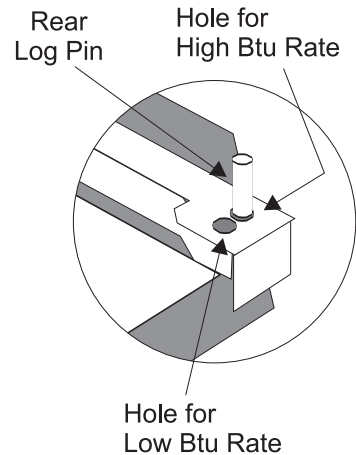

- 6) Reinstall Rear Log Bracket.
- 7) Remove burner orifice with a 1/2" wrench and discard.

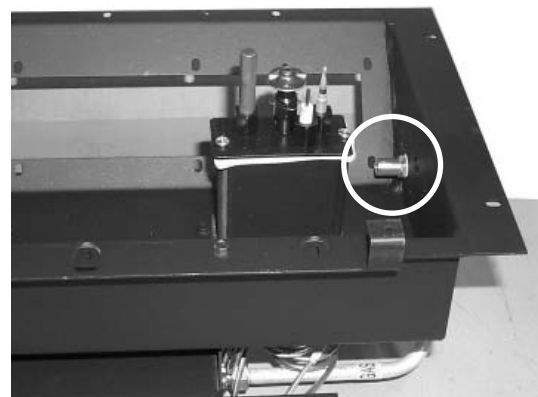

- 8) Reinstall new burner orifice (NG stamped #37 or LP stamped #52) and tighten.
- 9) Reverse steps 3) and 2).



# INSTALLATION

- 10) Adjust Vent restrictor setting: To set the Vent restriction as indicated in the diagram, simply loosen the screws and push the vent restrictor plate to the correct position. Tighten the screws.

Unit	Btu/h	Restrictor Opening
H35 NG	30,000	A 1-3/4" (45mm)
H35 LP	28,500	A 1-3/4" (45mm)

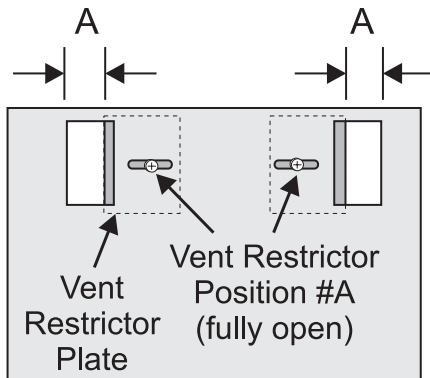

*Vent Restrictor setting at Low Btu for Straight Horizontal Venting*

- 11) Attach the label "This unit has been converted to..." on top of the Serial # decal over the higher Btu information.
- 12) Check for gas leaks.
- 13) Check inlet and outlet pressures.
- 14) Check operation of flame control. Check for proper flame appearance and glow on logs.

## OPTIONAL BRICK PANEL

- 1) Remove the cast top and glass front (see Glass Replacement section in this manual for instructions).
- 2) Remove the log set if installed.
- 3) Insert the back brick panel first by carefully slipping it between the back wall of the firebox and the rear log bracket.

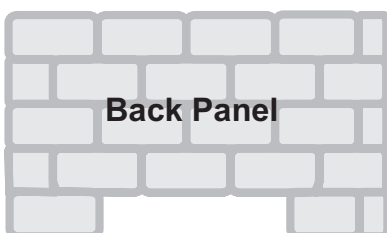

- 4) Before installing the side brick panels, loosen the screws for the brick tabs enough so that you can slide the brick tabs on to the screws easily but that the tabs are secure. For the location of the side brick tab screws see Diagram 1.

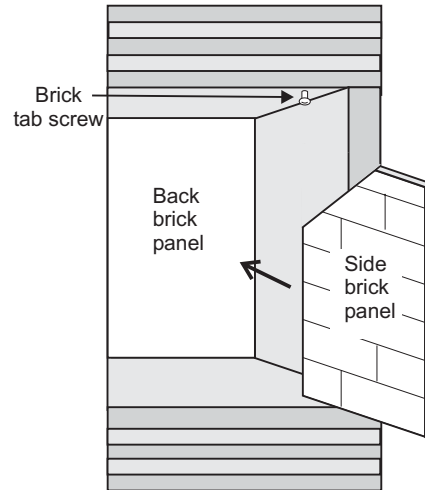
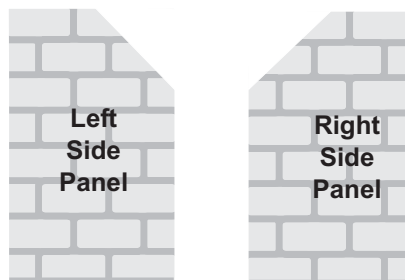

Diagram 1

- 5) Put the side panels in next. Slide them in from the front and push them flat up against the wall. Be very careful not to scratch them on the firebox hardware.



- 6) Install the brick tabs (refer to Diagram 2).

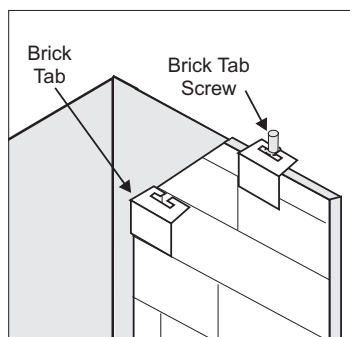

Diagram 2

### IMPORTANT

YOUR BRICK PANELS ARE  
MANUFACTURED FROM A SPECIAL HEAT  
REFLECTIVE CERAMIC MATERIAL  
*HANDLE WITH CARE*  
(DO NOT FORCE INTO POSITION)

## LOG SET INSTALLATION

Read the instructions below carefully and refer to the diagrams. If logs are broken do not use the unit until they are replaced. Broken logs can interfere with the pilot operation.

The gas log kit contains the following:

- 02-43 Rear Log
- 02-56 Middle Left Log
- 02-44 Front Left Log
- 02-46 Left Top Log
- 02-45 Front Right Log
- 02-47 Center Log
- 02-48 Middle Right Log
- Embers
- Lava
- Platinum Embers (supplied with packaged manual)

A) 02-43 D) 02-46 G) 02-48

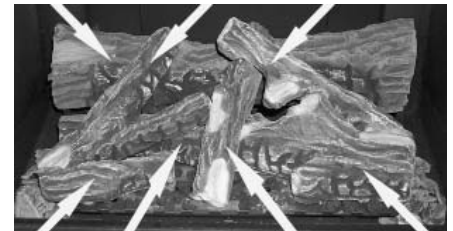

C) 02-44 B) 02-56 F) 02-47 E) 02-45

*The "02" refer numbers (i.e. 02-43) are molded into the rear of each log.*

- 1) Carefully remove the logs from the box and unwrap them. The logs are fragile, handle with care - **do not force into position**.
- 2) Lift off the Cast Top and remove the glass front (refer to the "Glass Replacement" section in this manual).
- 3) Sprinkle the embers on the left and right sides of the firebox base.

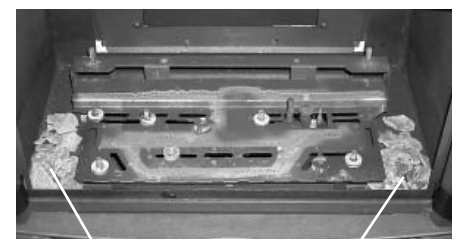

# INSTALLATION

- 4) Place Rear Log A)02-43 on the two pins on the rear log support.

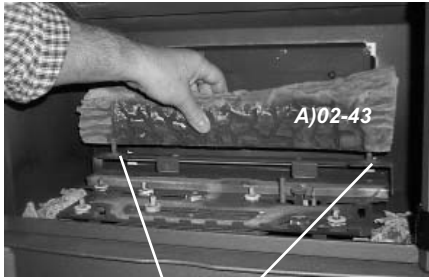

Pins on Rear Log Support

- 8) Place the Left Top Log D)02-46 on the pin on Log B)02-56 and on top of the cutout on Log A)02-43.

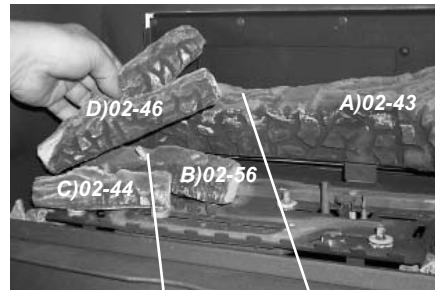

Pin Cutout

- 12) Position notch in Front Right Log G)02-48 on Log F)02-47 and push the bottom right edge against the bracket on the burner tray.

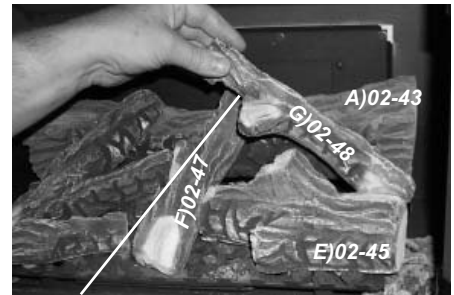

Notch

- 5) Place the Middle Left Log B)02-56 on the two pins as shown.



- 9) Place Front Right Log E)02-45 on the two pins as shown.

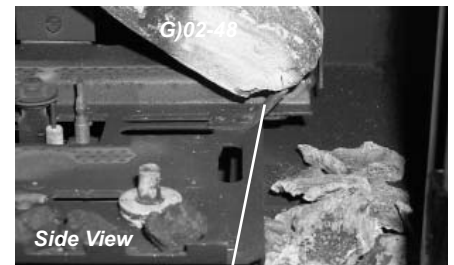

Side View Bracket

The bottom right edge of Log G)02-48 must sit snugly against the bracket. (Front Log 02-45 has been removed so that the bracket can be seen.)

- 6) Sprinkle some lava rock just in front of B)02-56 on the burner holes.

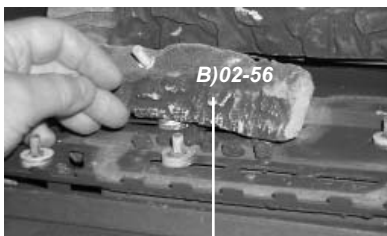

lava rock

- 10) Place the lava rock in the area between the left and right logs, leaving a space in the middle for log (F) 02-47.

Separate platinum embers and place on and around the lava rock. Avoid stacking platinum embers.

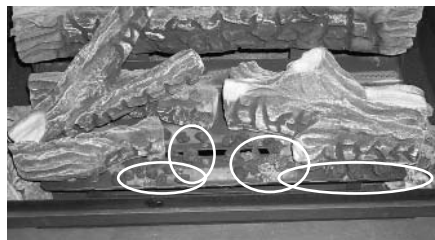

- 13) Test fire to ensure proper light off (make sure flame flows smoothly from one end of burner to the other. If there is any flame hesitation, check that area for any blockage of the burner port.

- 7) Place Front Left Log C)02-44 onto the 2 front pins as shown.



- 11) Place the notch in Center Log F)02-47 over Log E)02-45 and across the cutout on Log A)02-43.

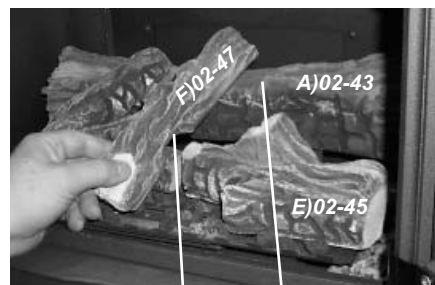

Notch Cutout



## DOUBLE DOOR INSTALLATION

- 1) Secure the Top Door Clip into the Top Front Casting.

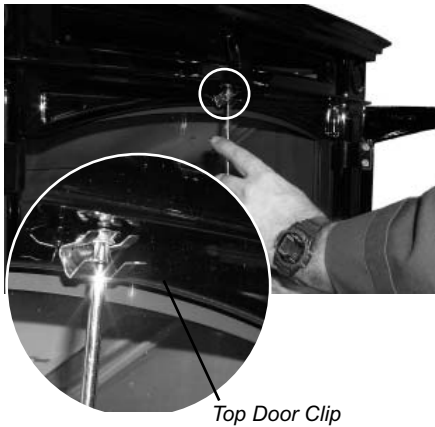

- 2) Pull all four door hinges out from the sides of the Front Casting.



- 3) Fasten the Right Door to the 2 right hinges (2 screws per hinge). Repeat for the Left Door.



## DECORATIVE DOOR GRILL INSTALLATION

- 1) Hook the Top Clip on the Decorative Door Grill into the top lip of the Front Casting.
- 2) Lift the Decorative Door Grill slightly and drop the Bottom Clips into the bottom lip of the Front Casting.

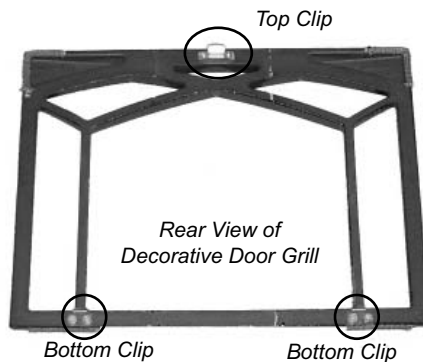

## TILE INSET INSTALLATION

### Side Tile Inset

- 1) Slide the Standard Side Tile Inset out towards the back of the unit.



- 2) Slide the Optional Side Tile Inset into the side panel, over the spring clip.
- 3) Repeat for other side.

### Top Tile Inset

- 1) Lift the Cast Top off the unit.



- 2) Place the Cast Top face down on a soft surface. Take care not to scratch the finish on the Top.

- 3) Remove the Tile Clips holding the Standard Tile Insets in place.

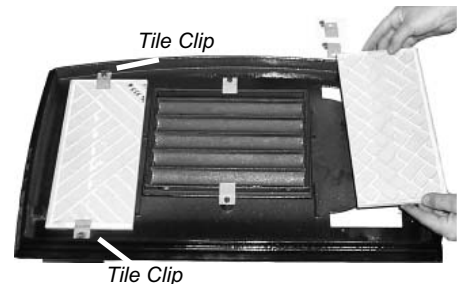

- 4) Place the Optional Tile Insets into position and secure with a top and bottom Tile Clip.

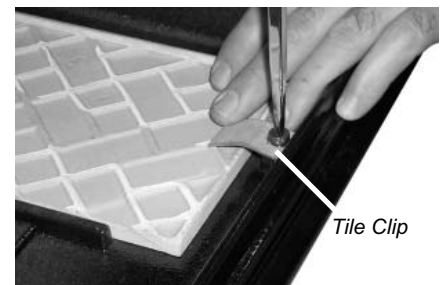

- 5) Replace the Cast Top on the unit.

# INSTALLATION

## DOOR HINGE REMOVAL

- 1) Remove the cast top by lifting it off of the stove.



- 2) Release the catches on the left and right side of the stove that secure the glass.

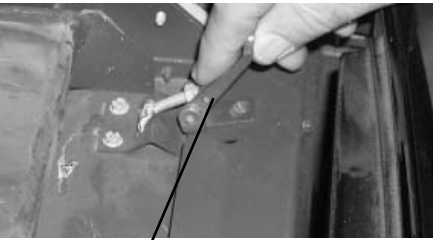

*Release catch by pulling up.*

- 3) Remove the glass by sliding it up and out.



- 4) Pull all four door hinges out from the sides of the front casting.



- 5) Use a 7/16" wrench to remove the screws that secure the door hinges.



*Remove screws.*

## WIRING DIAGRAMS

If any of the original wires as supplied with the appliance must be replaced, it must be replaced with CSA type SEW (200°C) or its equivalent.

This heater does not require a 120V A.C. supply for operation. In case of a power failure, the burner switch and the optional remote control/thermostat will continue to operate. However, a 120V A.C. power supply is needed for the fan/blower operation.

**Caution: Ensure that the wires do not touch any hot surfaces and are away from sharp edges.**

**CAUTION: Label all wires prior to disconnection when servicing controls. Wiring errors can cause improper and dangerous operation.**

### WARNING: Electrical Grounding Instructions

This appliance is equipped with a three pronged (grounding) plug for your protection against shock hazard and should be plugged directly into a properly grounded three-prong receptacle. Do not cut or remove the grounding prong from this plug.

## For NATURAL GAS Units and Units NOT Equipped with DC Spark Boxes

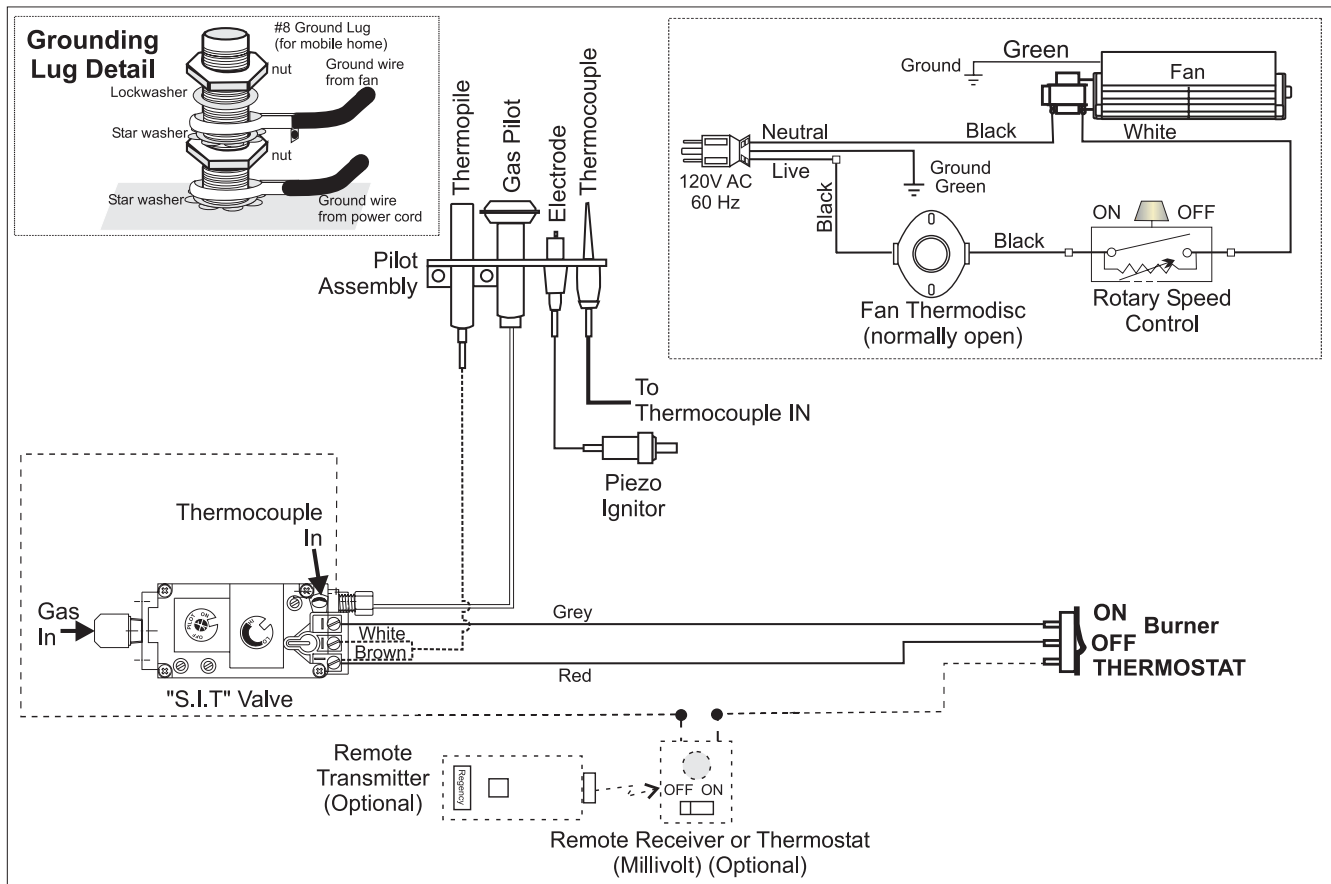

# INSTALLATION

## For PROPANE Units and Units Equipped with DC Spark Boxes\*

\*For installation of the DC Spark Box refer to the LP Conversion instructions in this manual.

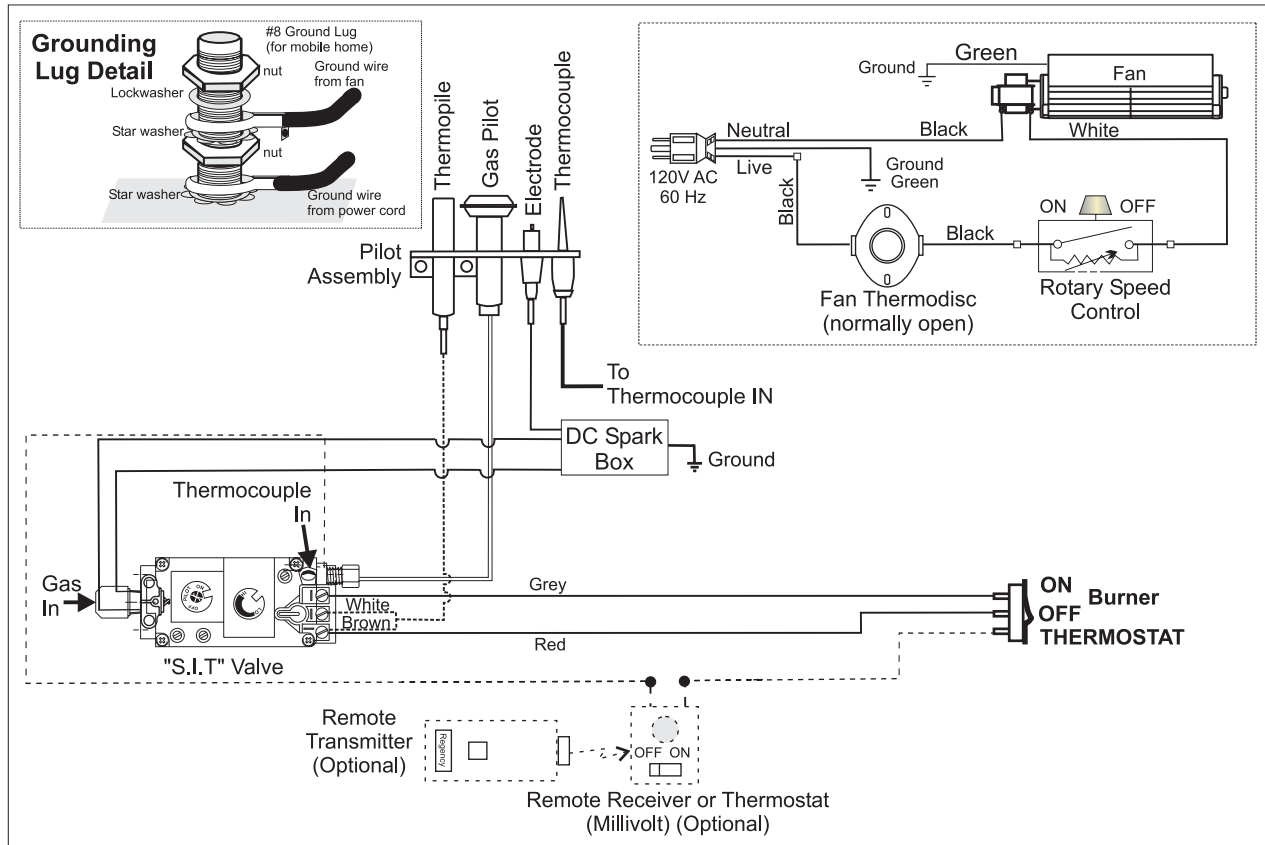

## WALL THERMOSTAT

A wall thermostat may be installed if desired. Connect the wires as per the wiring diagrams. Note that the wires are connected to the "TH" on the gas valve. Use table below to determine the maximum wire length:

**Note: Preferable if the thermostat is installed on an interior wall.**

Hampton® offers an optional programmable thermostat but any 250-750 millivolt rated non-anticipator type thermostat that is CSA, ULC or UL approved may be used.

**CAUTION**  
Do not connect the millivolt wall thermostat wires to the 120V wires.

### Thermostat Wire Table

Recommended Maximum Lead Length (Two-Wire) When Using Wall Thermostat (CP-2 System)	
Wire Size	Max. Length
14 GA.	50 Ft.
16 GA.	32 Ft.
18 GA.	20 Ft.
20 GA.	12 Ft.
22 GA.	9 Ft.

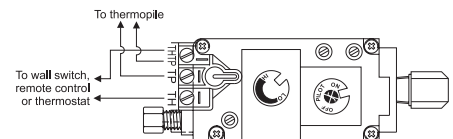

## REMOTE CONTROL

Use the Hampton® Remote Control Kit approved for this unit. Use of other systems may void your warranty.

The remote control kit comes with a hand held transmitter, a receiver and a wall mounting plate.



# OPERATING INSTRUCTIONS

- 1) Choose a convenient location on the wall to install the receiver and the receptacle box (protection from extreme heat is very important). Run wires from the fireplace to that location, use Thermostat Wire Table.
- 2) Connect the wires as per the wiring diagram below.

**CAUTION**  
Do not connect the millivolt remote control wires to the 120V wires.

- 3) Install 3 AAA alkaline batteries in transmitter and 4 AA alkaline batteries in the receiver. Install the receiver and its cover in the wall. Switch the remote receiver to "remote" mode. The remote control is now ready for operation.

## FINAL CHECK

Before leaving this unit with the customer, the installer must ensure that the appliance is firing correctly. This includes:

- 1) Clocking the appliance to ensure the correct firing rate (rate noted on label) at 15 minutes.
- 2) If required, adjusting the primary air to ensure that the flame does not carbon. First allow the unit to burn for 15 min. to stabilize.
- 3) Check for proper draft.

### CAUTION

Any alteration to the product that causes sooting or carboning that results in damage to the exterior facia is not the responsibility of the manufacturer.

## OPERATING INSTRUCTIONS

- 1) Read and understand these instructions before operating this appliance.
- 2) Check to see that all wiring is correct and enclosed to prevent possible shock.
- 3) Check to ensure there are no gas leaks.
- 4) Make sure the glass in the door frame is properly positioned. Never operate the appliance with the glass removed. Never strike the glass or slam the door shut.
- 5) Verify that the venting and cap are unobstructed.
- 6) Verify log placement. If the pilot cannot be

seen when lighting the unit - the logs have been incorrectly positioned.

- 7) The unit should never be turned off, and on again without a minimum of a 60 second wait.

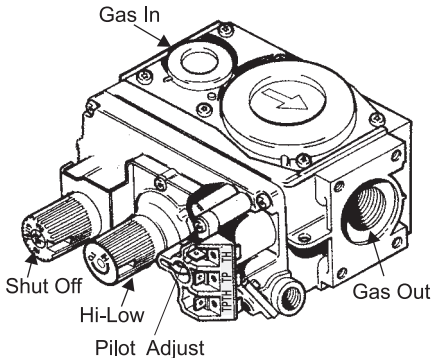

## LIGHTING PROCEDURE

**IMPORTANT**  
To ignite or reignite the pilot, the door to the firebox must be opened.

Only when the pilot holds, without pressure being applied to the control knob, should the door to the firebox be closed. The unit **must never** be operated with the glass or door open.

**NOTE:** For all propane units and units equipped with electric spark boxes, see "Copy of Lighting Plate Instructions" section for more details.

**IMPORTANT:** Gas on/off knob cannot be turned from "PILOT" to "OFF" unless it is partially depressed.

- 1) Turn stove OFF using the Burner "ON/OFF" switch remote or thermostat.
- 2) Turn gas control knob so indicator points to "OFF" position and allow 5 minutes for any gas in the combustion chamber to escape.
- 3) Turn gas control knob counterclockwise so indicator points to the "PILOT" position. Depress the gas control knob fully. Depress the igniter button several times until the pilot lights. After approximately one minute, release the gas control knob. The pilot flame should continue to burn. If the pilot does not remain lit, repeat operation allowing a longer period before releasing gas control knob.

- 4) When the pilot stays lit, turn the gas knob further counterclockwise to the "ON" position.
- 5) Use the thermostat or remote control to turn on the unit.
- 6) Rotate the flame height regulator to adjust the flame height higher or lower.

## SHUTDOWN PROCEDURE

- 1) Use the thermostat or remote control to turn off the main burner.
- 2) Turn the main gas control clockwise to the "OFF" position to turn off the pilot (push knob in slightly).
- 3) Turn off all electric power to appliance if service is to be performed.

## FIRST FIRE

The **FIRST FIRE** in your stove is part of the paint curing process. To ensure that the paint is properly cured, it is recommended that you burn your fireplace for at least four (4) hours the first time you use it with the fan on. When first operated, the unit will release an odour caused by the curing of the paint and the burning off of any oils remaining from manufacturing. Smoke detectors in the house may go off at this time. Open a few windows to ventilate the room for a couple of hours. The glass may require cleaning.

**DO NOT ATTEMPT TO CLEAN THE GLASS WHILE IT IS STILL HOT!**

**Note:** When the glass is cold and the appliance is lit, it may cause condensation and fog the glass. This condensation is normal and will disappear in a few minutes as the glass heats up.

**DO NOT BURN THE APPLIANCE WITHOUT THE GLASS FRONT IN PLACE.**

During the first few fires, a white film may develop on the glass front as part of the curing process. The glass should be cleaned or the film will bake on and become very difficult to remove. Use a non-abrasive cleaner and NEVER clean the glass while it is hot.

# OPERATING INSTRUCTIONS

## COPY OF THE LIGHTING PLATE INSTRUCTIONS

### FOR YOUR SAFETY READ BEFORE LIGHTING

This appliance must be installed in accordance with local codes, if any; if none, follow the National Fuel Gas Code, ANSI Z223.1/ NFPA 54, or Natural Gas and Propane Installation Codes, CSA B149.1. (Australia: AS5601-2004, New Zealand: NZS 5261)

**WARNING: If you do not follow these instructions exactly, a fire or explosion may result causing property damage, personal injury or loss of life. Improper installation, adjustment, alteration, service or maintenance can cause injury or property damage. Refer to the owner's information manual provided with this appliance. For assistance or additional information consult a qualified installer, service agency or gas supplier.**

- A) This appliance has a pilot which must be lighted by hand, following the instructions below exactly.
- B) BEFORE LIGHTING smell all around the appliance area for gas. Be sure to smell next to the floor because some gas is heavier than air and will settle on the floor.
- WHAT TO DO IF YOU SMELL GAS
- Do not try to light any appliance
  - Do not touch any electric switch, do not use any phone in your building
  - Immediately call your gas supplier from a neighbors phone. Follow the gas supplier's instructions.
  - If you cannot reach your gas supplier, call the fire department.
- C) Use only your hand to push in or turn the gas control knob. Never use tools. If the knob will not push in or turn by hand, don't try to repair it, call a qualified service technician. Force or attempted repair may result in a fire or explosion.
- D) Do not use this appliance if any part has been under water. Immediately call a qualified service technician to inspect the appliance and to replace any part of the control system and any gas control which has been under water.
- E) This appliance needs fresh air for safe operation and must be installed so there are provisions for adequate combustion and ventilation air.

**CAUTION: Hot while in operation. Do not touch. Severe Burns may result. Due to high surface temperatures keep children, clothing and furniture, gasoline and other liquids having flammable vapors away. Keep burner and control compartment clean. See installation and operating instructions accompanying appliance.**

### LIGHTING INSTRUCTIONS

STOP! Read the safety information above on this label.

#### FOR UNITS NOT EQUIPPED WITH ELECTRIC SPARK:

- 1) Push in gas control knob slightly and turn clockwise to "OFF". Knob cannot be turned from "PILOT" to "OFF" unless knob is pushed in slightly. Do not force.

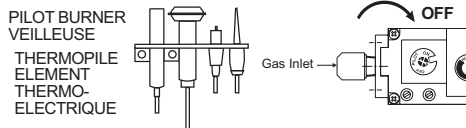

- 2) Wait five (5) minutes to clear out any gas. If you then smell gas STOP! follow "B" in the safety information above on this label. If you don't smell gas, go to the next step.
- 3) Turn knob on gas control counterclockwise to "PILOT".
- 4) Push in control knob all the way and hold in. Immediately push black button on spark igniter until pilot lights. Continue to hold the control knob in for about 1/2 minute after the pilot is lit. Release knob and it will pop back up. Pilot should remain lit. If it goes out, repeat steps 3) and 4).  
If knob does not pop up when released, stop and immediately call your service technician or gas supplier.  
If the pilot will not stay lit after several tries, turn the gas control knob to "OFF" and call your service technician or gas supplier.
- 5) Turn gas control knob counterclockwise to "ON".
- 6) Use rocker switch to operate main burner.

#### FOR ALL PROPANE UNITS AND UNITS EQUIPPED WITH ELECTRIC SPARK BOXES:

- 1) Push in gas control knob slightly and turn to "PILOT" position.
- 2) Push in control knob all the way and hold in until the pilot lights up. Continue to hold the control knob in for about 20 seconds after the pilot is lit. Release knob.
- 3) Push in gas control knob slightly and turn to "ON" position.
- 4) Turn ON the flame switch.

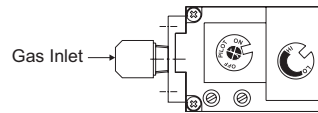

### TO TURN OFF GAS APPLIANCE

- 1) Turn off the flame switch.
- 2) Push in the gas control knob slightly and turn clockwise to "OFF". Do not force.
- 3) Turn off all electric power to the appliance if service is to be performed.
- You may shut off the pilot during prolonged non use periods to conserve fuel.

**DO NOT REMOVE THIS INSTRUCTION PLATE**

918-474a

## ADJUSTING FLAME HEIGHT

Your heater has an adjustable flame to tailor the look and heat output to your specific needs. It is adjusted by turning the flame adjustment dial on the gas control valve.

Turn clockwise to adjust the flame higher, counterclockwise for a lower flame.

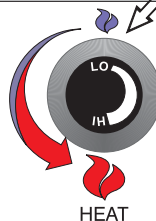
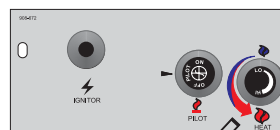

## AUTOMATIC CONVECTION FAN OPERATION

The fan operates automatically - turn the knob at the top right rear corner to adjust to the desired speed. The fan will turn on as the stove comes up to operating temperature. After the unit has been turned off and the unit cooled to below a useful heat output range the fan will shut off automatically.

## NORMAL OPERATING SOUNDS OF GAS APPLIANCES

It is possible that you will hear some sounds from your gas appliance. This is perfectly normal due to the fact that there are various gauges and types of steel used within your appliance. Listed below are some examples. All are **normal operating sounds** and should not be considered as defects in your appliance.

### Blower:

Hampton® gas appliances use high tech blowers to push heated air farther into the room. It is not unusual for the fan to make a "whirring" sound when ON. This sound will increase or decrease in volume depending on the speed setting of your fan speed control.

### Burner Tray:

The burner tray is positioned directly under the burner tube(s) and logs and is made of a different gauge material from the rest of the firebox and body. Therefore, the varying thicknesses of steel will expand and contract at slightly different rates which can cause "ticking" and "cracking" sounds. You should also be aware that as there are temperature changes within the unit these sounds will likely re-occur. Again, this is normal for steel fireboxes.

### Blower Thermodisc:

When this thermally activated switch turns ON it will create a small "clicking" sound. This is the switch contacts closing and is normal.

### Pilot Flame:

While the pilot flame is on it can make a very slight "whisper" sound.

### Gas Control Valve:

As the gas control valve turns ON and OFF, a dull clicking sound may be audible, this is normal operation of a gas regulator or valve.

### Unit Body/Firebox:

Different types and thicknesses of steel will expand and contract at different rates resulting in some "cracking" and "ticking" sounds will be heard throughout the cycling process.

2) Clean glass (never when unit is hot), appliance, and door with a damp cloth. Never use an abrasive cleaner.

3) The heater is finished in a porcelain finish or with a heat resistant paint and should only be refinished with heat resistant paint (not with wall paint).

Never use an abrasive cleaner on the porcelain finish as it may scratch the surface.

4) Make a periodic check of burner for proper position and condition. Visually check the flame of the burner periodically, making sure the flames are steady; not lifting or floating. If there is a problem, call a qualified service person.

5) **CAUTION:** Label all wires prior to disconnection when servicing controls. Wiring errors can cause improper and dangerous operation.

6) The appliance and venting system must be inspected before use, and at least annually, by a qualified field service person, to ensure that the flow of combustion and ventilation air is not obstructed. During the annual service call, the burners should be removed from the burner tray and cleaned. Replace the embers but do not block the pilot.

7) Keep the area near the appliance clear and free from combustible materials, gasoline, and other flammable vapours and liquids.

**CAUTION: ANY SAFETY SCREEN OR GUARD REMOVED FOR SERVICING AN APPLIANCE MUST BE REPLACED PRIOR TO OPERATING THE APPLIANCE.**

**CLOTHING OR OTHER FLAMMABLE MATERIAL SHOULD NOT BE PLACED ON OR NEAR THE APPLIANCE.**

8) Each time the appliance is lit, it may cause condensation and fog the glass. This condensation and fog is normal and will disappear in a few minutes as the glass heats up.

**Never operate the appliance without the glass properly secured in place.**

9) Periodically check the pilot flames. Correct flame pattern has three strong blue flames: 1 flowing around the thermopile and 1 around the thermocouple, and 1 flowing across the rear of the burner (it does not have to be touching the burner).

**Note: If you have an incorrect flame pattern, contact your Hampton® dealer for further instructions.**

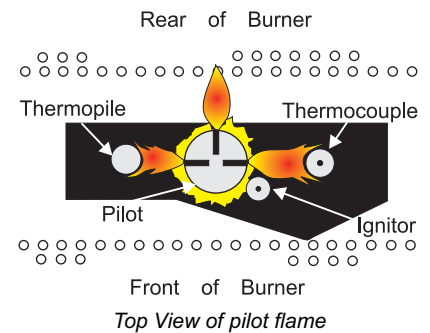

Incorrect flame pattern will have small, probably yellow flames, not coming into proper contact with the rear of the burner or thermopile.

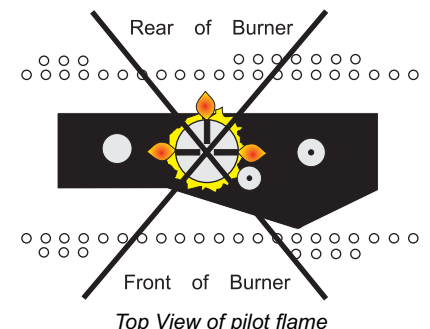

**WARNING: CHILDREN AND ADULTS SHOULD BE ALERTED TO THE HAZARDS OF HIGH SURFACE TEMPERATURE AND SHOULD STAY AWAY TO AVOID BURNS OR CLOTHING IGNITION. YOUNG CHILDREN SHOULD BE CAREFULLY SUPERVISED WHEN THEY ARE IN THE SAME ROOM AS THE APPLIANCE.**

**DO NOT USE THIS APPLIANCE IF ANY PART HAS BEEN UNDER WATER. IMMEDIATELY CALL A QUALIFIED SERVICE TECHNICIAN TO INSPECT THE APPLIANCE AND TO REPLACE ANY PART OF CONTROL SYSTEM AND ANY GAS CONTROL WHICH HAS BEEN UNDER WATER.**

## MAINTENANCE INSTRUCTIONS

1) Always turn off the valve before cleaning. For relighting, refer to lighting instructions. Keep the burner and control compartment clean by brushing and vacuuming at least once a year. When cleaning the logs, use a soft clean paint brush as the logs are fragile and easily damaged.

# MAINTENANCE

## GENERAL VENT MAINTENANCE

Conduct an inspection of the venting system semi-annually. Recommended areas to inspect as follows:

- 1) Check the Venting System for corrosion in areas that are exposed to the elements. These will appear as rust spots or streaks, and in extreme cases, holes. These components should be replaced immediately.
- 2) Remove the Cap, and shine a flashlight down the Vent. Remove any bird nests, or other foreign material.
- 3) Check for evidences of excessive condensation, such as water droplets forming in the inner liner, and subsequently dripping out the joints. Continuous condensation can cause corrosion of caps, pipe, and fittings. It may be caused by having excessive lateral runs, too many elbows, and exterior portions of the system being exposed to cold weather.
- 4) Inspect joints, to verify that no pipe sections or fittings have been disturbed, and consequently loosened. Also check mechanical supports such as Wall Straps, or plumbers' tape for rigidity.

## LOG REPLACEMENT

The unit should never be used with broken logs. Turn off the gas valve and allow the unit to cool before opening door to carefully remove the logs. The pilot light generates enough heat to burn someone. If for any reason a log should need replacement, you must use the proper replacement log. The position of these logs must be as shown in the diagram under Log Installation.

**Note: Improper positioning of logs may create carbon build-up and will alter the unit's performance which is not covered under warranty.**

## GLASS REPLACEMENT

Your stove is supplied with high temperature, 5 mm Neoceram ceramic glass that will withstand the highest heat that your unit will produce. In the event that you break your glass by impact, purchase your replacement door from an authorized Hampton® dealer only, and follow our step-by-step instructions for replacement.

- 1) Lift off the Cast Top.



- 2) Open the 2 latches of the Glass Front.



Latches

- 3) Lift the Glass Front Assembly up.



- 4) Remove the glass and replace with the new glass.
- 5) Replace the door and Cast Top.

Replacement Part # 940-324 Glass

**WARNING: Do not operate appliance with glass panel removed, cracked or broken. Replacement of the glass should be done by a licensed or qualified service person.**

**Note: Wearing gloves will protect your hands while handling glass.**

## FAN MAINTENANCE

If your fan requires maintenance or replacement, access to the fan is through the rear access panel on the back of the unit. **NOTE: the unit MUST NOT be operated without the fan access panel securely in place and correctly sealed.**

**IMPORTANT: These fans collect a lot of dust from within your home. Ensure you maintain these fan motors on a regular basis by vacuuming out the fan squirrel cages, around the motor, and around the grills on the back of the stove.**

### WARNING:

**Electrical Grounding Instructions**  
This appliance is equipped with a three pronged (grounding) plug for your protection against shock hazard and should be plugged directly into a properly grounded three-prong receptacle. Do not cut or remove the grounding prong from this plug.

**IMPORTANT**  
Disconnect power supply before servicing

To remove fan:

- 1) Unplug or disconnect power source to stove.
- 2) Remove the 6 screws holding the access panel in place.

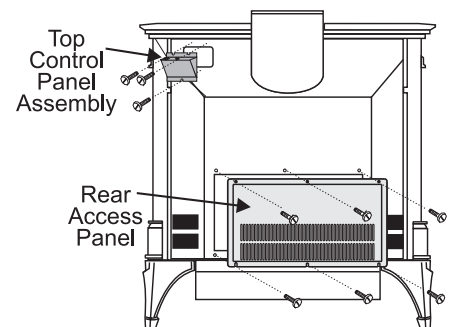

- 3) Unclip the black and white wires from the fan motor.
- 4) Lift fan off of the 2 pins, tip back and pull through rear panel. Do not tear or damage the flex pipe when removing the fan. Disconnect the green ground wire from the right side of the fan as soon as you can reach it.



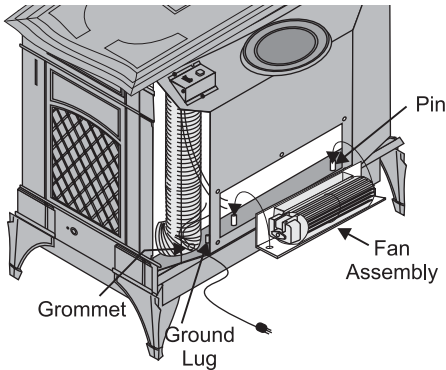

## Replacing the Fan:

Reverse the above steps (1 - 4). Make sure the fan wires and the ground wire are reattached.

*Hint for pushing fan down onto pins - rub a bit of dish soap on the grommet so it will slide more easily onto the pin. Check to make sure the fan is seated properly on the pins - try to move the fan back and forth, there should be no noise, if there is check that the grommets haven't come loose.*

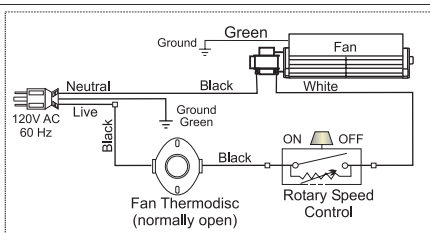

## REMOVING VALVE

If your valve requires maintenance or replacement, use the following instructions:

**Note:** Always close off the gas supply before removing the valve.

- 1) If optional fan is installed, disconnect power source to stove.
- 2) Remove access panel.

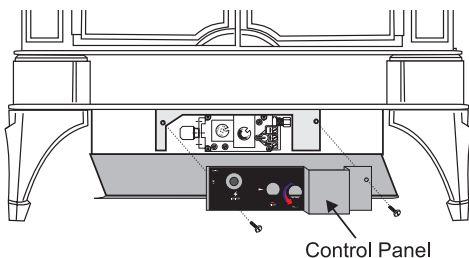

- 3) Disconnect gas line to stove.
- 4) Disconnect 3/8" NPT pipe from 90° elbow on valve.
- 5) Disconnect the two (2) switch wires from valve.

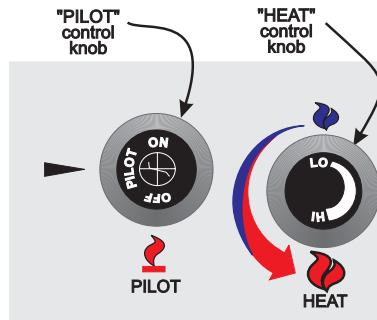

- 6) Disconnect piezo wire.
- 7) Lift off the Cast Top and lift out the front door.
- 8) Carefully remove the logs, embers and rockwool.
- 9) Remove burner (see diagram below).

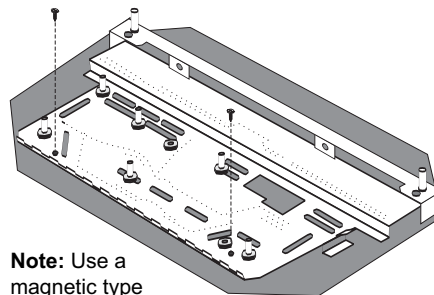

**Note:** Use a magnetic type screwdriver if possible.

- 10) Remove all 18 screws holding the burner tray assembly in place.

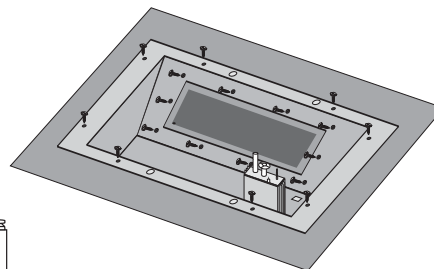

- 11) Carefully lift the burner tray assembly out.

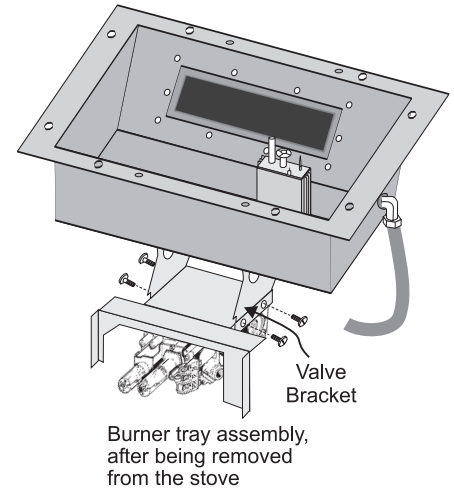

- 12) To replace the burner tray assembly, simply reverse these instructions.

**To remove valve from valve assembly, continue.**

- 13) Remove two (2) thermopile wires.
- 14) Remove thermocouple with a 9 mm (metric) wrench.
- 15) Remove pilot nut with an 11 mm wrench.
- 16) Remove valve to orifice nut with a 13/16" wrench.
- 17) Remove inlet pipe with pipe wrench. Note orientation of 90° elbow.
- 18) Remove two (2) phillips head M5 screws on each side of the valve.
- 19) Remove valve and remove gas out 90° brass fitting. Note orientation of fitting.

## INSTALLING VALVE ASSEMBLY

- 1) To install a new valve assembly, reverse instructions for **removing valve**. See assembly steps 1-12.
- 2) Check for leaks and manifold pressure. See **Gas Pressure Test** instructions.
- 3) To reinstall valve, reverse instructions for removing valve assembly, steps 13-19.

# PARTS LIST

## MAIN ASSEMBLY

Part #	Description	Part #	Description	Part #	Description
1)	942-301** Casting - Top	56)	W842051 Gasket - Upper Air Passage Top	908-106	Decal-Rear Control Panel
2)	942-311** Casting - Top Grill	57)	W260108 Gasket - Upper Air Passage Bottom	260-917	Fan Assembly (Option)
3)	942-321** Casting - Left Side	58)	630-009 Gasket - Lower Air Passage	141)	910-331/P Fan Blower
4)	942-331** Casting - Right Side	59)	* Upper Air Passage Assy	143)	910-330 Fan Speed Control (120 V)
5)	942-341** Casting - Front	61)	945F Direct Vent Adaptor	144)	904-569 Knob - Fan Speed Control
6)	740-931** Casting - Double Door			910-794	910-794 Power Cord (120 V)
8)	942-371** Casting - Bottom Skirt			918-518	Manual
9)	942-381** Casting - Leg				
10)	942-391** Casting - Insert Plate - Top				
11)	942-401** Casting - Insert Plate - Side				
12)	948-219 Hampton® Logo Plate	114)	* Wire Tie Wrap		
14)	740-062 Top Insert Bracket	115)	* Wire Tie Mount Button		
15)	904-209 Concealed Hinge	118)	910-897 High Temperature Wire Harness - Fan End		
16)	740-069 Cast Door Catch - Top	119)	* Grommet for Power Cord		
17)	740-067 Cast Door Catch - Lower	134)	740-049 Rear Panel		
	740-542 Front Door Assembly	135)	260-037 Rear Control Panel		
18)	740-051 Door Support	136)	910-241 Burner ON/OFF Switch		
19)	740-055 Door Frame	137)	* Hole Plug 0.375		
22)	41225 Gasket - Tadpole	138)	630-021 Fan Access Panel		
23)	940-324/P Replacement Glass	139)	910-233 Fan Thermodisc Auto On/Off		
24)	740-056 Glass Bracket				
25)	948-255 Latch				
26)	740-548 Relief Door Assembly				
27)	740-059 Gasket - Mounting Relief				
38)	740-921** Front Grill (Optional)				
39)	* Firebox				
	Baffle Restrictor Assembly				
44)	730-029 Restrictor				
45)	740-048 Baffle for Firebox				
46)	* Heat Exchanger Assy				
47)	* Transition Box Assy				
48)	740-077 Side Insert Bracket				
	Top Relief Door Assembly				
50)	W260260 Top Relief Frame Gasket				
51)	942-117 Top Relief Frame				
52)	W260280 Top Relief Plate Gasket				
53)	290-021 Top Relief Plate				
54)	* Capscrew 1/4 x 1-3/4 NC				
55)	* Gasket - Transition Box/Air Passage				

\*Note: Not available as a replacement part.

\*\*Last digit of part number indicated colour:  
1=Charcoal Grey, 3=Slate Blue, 4=Ivory,  
5=Timberline Brown.

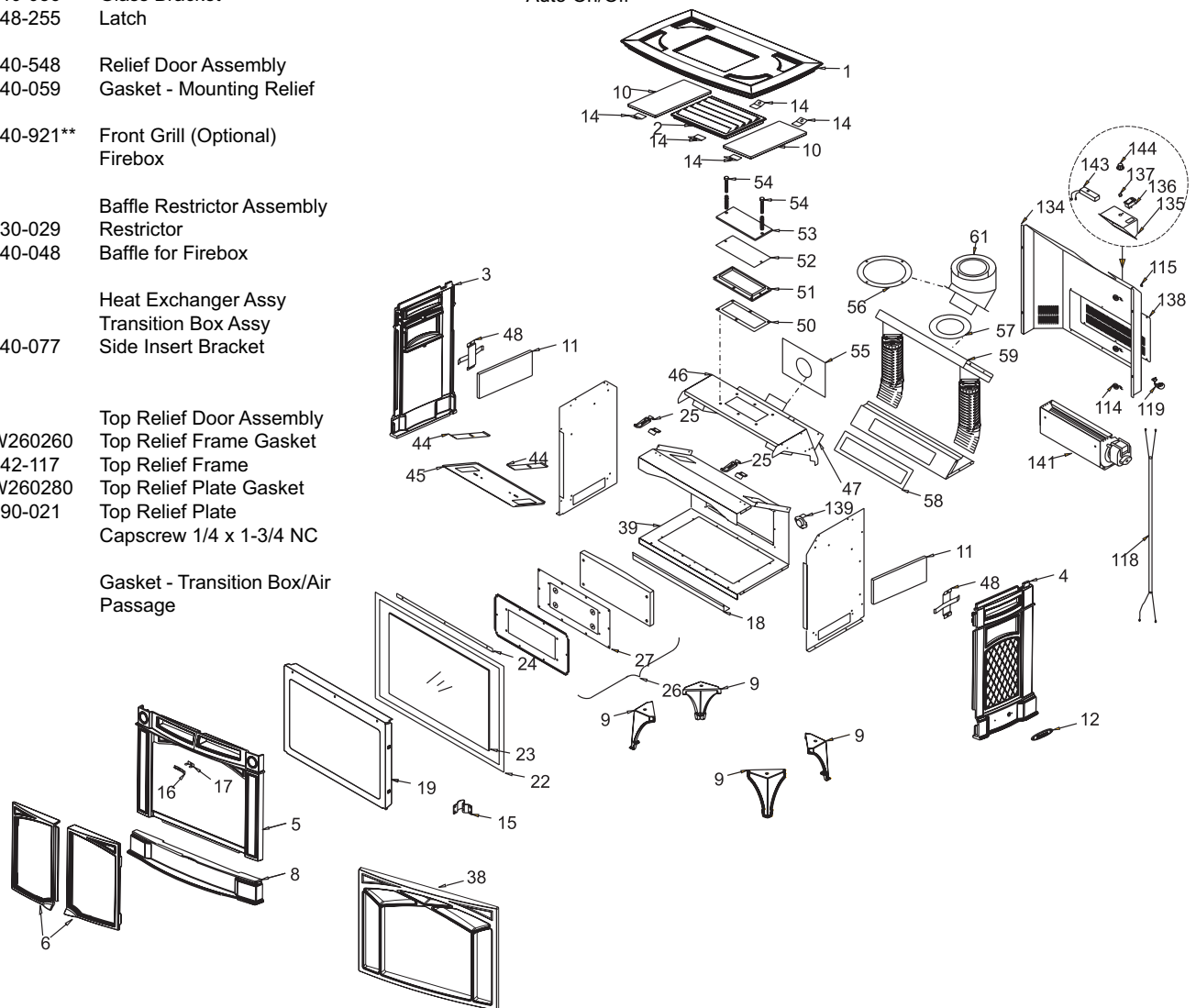



## BURNER & LOG ASSEMBLY

Part #	Description
	740-574/P Valve Assembly S.I.T. - Natural Gas
	740-576/P Valve Assembly S.I.T. - Propane
60)	910-478 Valve S.I.T. - NG/LP
	904-689 #33 Orifice - N.G.
	904-645 #51 Orifice - LP
63)	910-190 Piezo Ignitor & Nut
64)	908-672 Control Panel Decal
65)	490-061 Switch Plate
	910-897 High Temperature Wire Harness (Fan End)
	936-170 Orifice Gasket
66)	910-038 Pilot Assy-SIT-3 flame-NG
	910-039 Pilot Assy-SIT-3 flame-LP
67)	730-041 Pilot Holder
68)	W840470 Pilot Assembly Gasket
69)	* Valve Shield
70)	* Valve Bracket
71)	* Valve Gasket
72)	* Front Support
73)	730-528 Rear Log Bracket Assy
75)	402-935 Log Set
	740-572 Ember Package
78)	730-550 Burner Assy
	740-546 Base Assembly
79)	* Base Plate
80)	* Brick Panel - Right Side
81)	* Brick Panel - Left Side
82)	* Brick Panel - Back
83)	400-090 Brick Clip
84)	948-042 Hinge of Valve Access Door
85)	260-056 Valve Access Door
86)	260-565 Air Shutter Gear Assembly - Female
87)	904-700 T-Handle Hex Key 3/16"
88)	630-008 Burner Tray Firebox Gasket
89)	260-560 Air Shutter Gear Assembly - Male
90)	* Burner Box
	791-969 Conversion Kit from Natural Gas to Propane

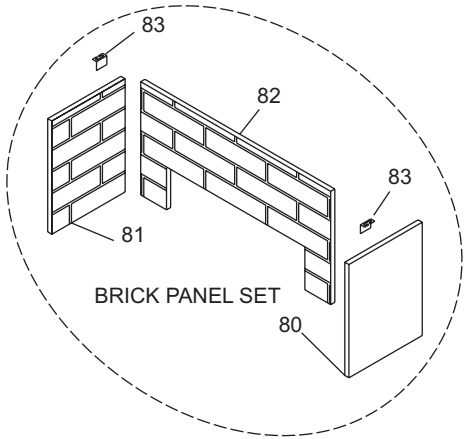
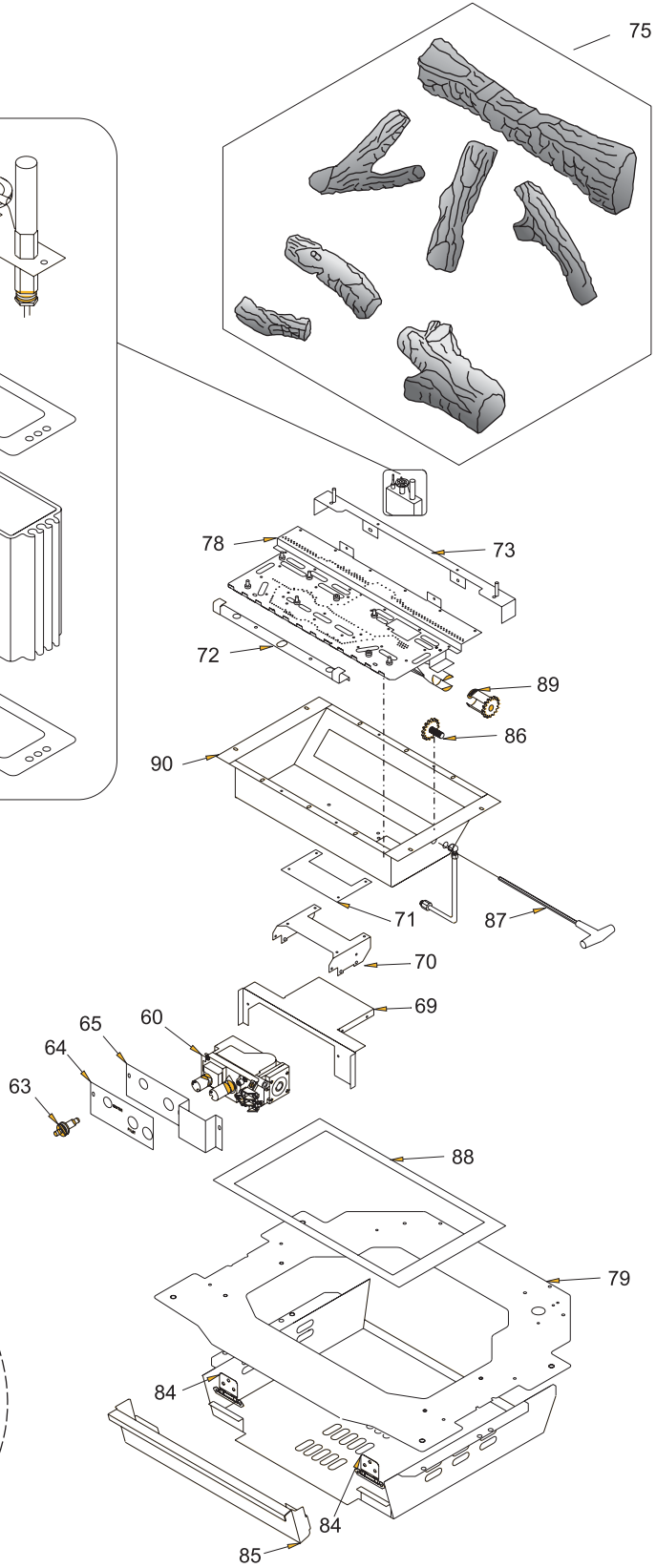
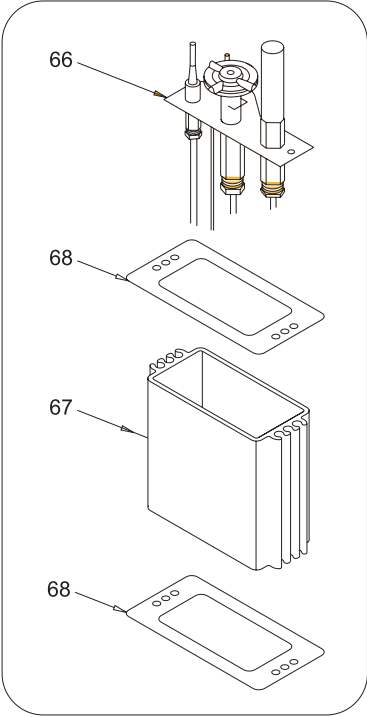

**\*Note:** Not available as a replacement part.





Hampton Fireplace Products are designed with reliability and simplicity in mind. In addition, our internal Quality Assurance Team carefully inspects each unit thoroughly before it leaves our facility. FPI Fireplace Products International Ltd. is pleased to extend this limited lifetime warranty to the original purchaser of a Hampton Product. This warranty is not transferable.

**The Warranty:** Limited Lifetime

External casting, not directly in contact with the fire, such as hobs, sides, ash lips, legs, fronts and fire doors, are covered against cracks and warps resulting from manufacturer defects, parts and subsidized labour\* for three (3) years from the date of purchase and parts only thereafter.

The combustion chamber, heat exchanger, burner tubes/pans and logs are covered under the Limited Lifetime Warranty for five (5) years for parts and subsidized labour\* and parts only thereafter.

Glass is covered for lifetime against thermal breakage only, parts and subsidized labour\* for five (5) years and parts only thereafter from date of purchase.

Electrical and mechanical components such as blowers, switches, wiring, thermodiscs, FPI remote controls, spill switches, thermopiles, thermocouples, pilot assembly components, and gas valves are covered for two years parts and one year subsidized labour\* from the date of purchase. Blowers and valves replaced under warranty are considered repairs and continue as if new with appliance. ie. twelve (12) months from original purchase date of appliance with a minimum of three (3) months coverage from date of replacement.

FPI venting components are covered parts and subsidized labour\* for three (3) years from date of purchase.

Simpson Dura-Vent venting components are covered by Simpson Dura-Vent Inc. warranty.

Repair/replacement parts purchased by the consumer from FPI after the original coverage has expired on the unit will carry a 90 day warranty, valid with a receipt only. Any item shown to be defective will be repaired or replaced at our discretion. No labor coverage is included with these parts.

**Conditions:**

Porcelain/Enamel - Absolute perfection is neither guaranteed nor commercially possible. Any chips must be reported and inspected by an authorized dealer within three days of installation. Reported damage after this time will be subject to rejection.

Any part or parts of this unit which in our judgement show evidence of such defects will be repaired or replaced at FPI's option, through an accredited distributor or agent provided that the defective part be returned to the distributor or agent **Transportation Prepaid**, if requested.

It is the general practice of FPI to charge for larger, higher priced replacement parts and issue credit once the replaced component has been returned to FPI and evaluated for manufacturer defect.

The authorized selling dealer is responsible for all in-field service work carried out on your Hampton product. FPI will not be liable for results or costs of workmanship from unauthorized service persons or dealers.

At all times FPI reserves the right to inspect product in the field which is claimed to be defective.

All claims must be submitted to FPI by authorized selling dealers. It is essential that all submitted claims provide all of the necessary information including customer name, purchase date, serial #, type of unit, problem, and part or parts requested, without this information the warranty will be invalid.

**Exclusions:**

This limited Lifetime Warranty does not extend to or include paint (charcoal units), porcelain (including pinholes, scratches and minor shade mismatch), door or glass gasketing or trim.

At no time will FPI be liable for any consequential damages which exceed the purchase price of the unit. FPI has no obligation to enhance or modify any unit once manufactured. ie. as products evolve, field modifications or upgrades will not be performed.

FPI will not be liable for travel costs for service work.

Installation and environmental problems are not the responsibility of the manufacturer and therefore are not covered under the terms of this warranty policy.

Embers, door and glass, gaskets, door handles, paint are not covered under the terms of this warranty policy.

Any unit which shows signs of neglect or misuse is not covered under the terms of this warranty policy.

The warranty will not extend to any part which has been tampered with or altered in any way, or in our judgment has been subject to misuse, improper installation, negligence or accident, spillage or downdrafts caused by environmental or geographical conditions, inadequate ventilation, excessive offsets, negative air pressure caused by mechanical systems such as furnaces, fans, clothes dryer, etc.

Freight damage to stoves and replacement parts is not covered by warranty and is subject to a claim against the freight carrier by the dealer.

FPI will not be liable for acts of God, or acts of terrorism, which cause malfunction of the appliance.

Performance problems due to operator error will not be covered by this warranty policy.

Products made or provided by other manufacturers and used in conjunction with the operation of this appliance without prior authorization from FPI, may nullify your warranty on this product.

Any alteration to the unit which causes sooting or carboning that results in damage to the interior / exterior facia is not the responsibility of FPI.

\* Subsidy according to job scale as predetermined by FPI.

**Hampton® fireplace products are designed with reliability and simplicity in mind. In addition, our internal Quality Assurance Team carefully inspects each unit thoroughly before it leaves our door.**

**FPI Fireplace Products International Ltd. is pleased to extend this Limited Lifetime Warranty to the original purchaser of a Hampton® Product.**

**See the inside back cover for details.**

**Register your Hampton® online at  
<http://www.hampton-fire.com>**

*Installer: Please complete the following information*

**Dealer Name & Address:** \_\_\_\_\_  
\_\_\_\_\_

**Installer:** \_\_\_\_\_

**Phone #:** \_\_\_\_\_

**Date Installed:** \_\_\_\_\_

**Serial No.:** \_\_\_\_\_