

**Liberty® LRI3E / Regency Horizon® HRI3E  
Gas Insert**

**Owners &  
Installation Manual**



[www.regency-fire.com](http://www.regency-fire.com)

MODELS: LRI3E-NG11 Natural Gas  
HRI3E-NG11 Natural Gas

LRI3E-LP11 Propane  
HRI3E-LP11 Propane

**⚠ WARNING**  
**FIRE OR EXPLOSION HAZARD**  
Failure to follow safety warnings exactly could result in serious injury, death, or property damage.

- Do not store or use gasoline or other flammable vapors and liquids in the vicinity of this or any other appliance.

**- WHAT TO DO IF YOU SMELL GAS**

- Do not try to light any appliance.
- Do not touch any electrical switch: do not use any phone in your building. Leave the building immediately.
- Immediately call your gas supplier from a neighbour's phone. Follow the gas supplier's instructions.
- If you cannot reach your gas supplier, call the fire department.

- Installation and service must be performed by a qualified installer, service agency or the gas supplier.



Certified to/Certifié pour: CSA 2.17-2017  
ANSI Z21.88-2019  
CSA 2.33-2019

**Installer:** Please complete the details on the back cover and leave this manual with the homeowner.  
**Homeowner:** Please keep these instructions for future reference.

## TO THE NEW OWNER

**Congratulations! You are the owner of a state-of-the-art Gas Insert by Regency.**

**The Regency Gas Insert Series of hand crafted appliances has been designed to provide you with all the warmth and charm of a fireplace, at the flick of a switch. The models LRI3E-11 / HRI3E-11 of this series have been approved by Warnock Hersey/Intertek for both safety and efficiency. As it also bears our own mark, it promises to provide you with economy, comfort and security for many trouble free years to follow.**

**Please take a moment now to acquaint yourself with these instructions and the many features of your Regency Fireplace.**



# DANGER

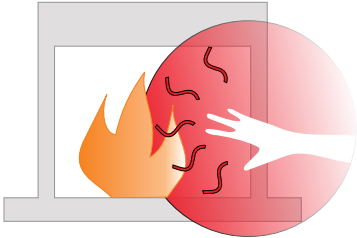

**HOT GLASS WILL  
CAUSE BURNS**

**DO NOT TOUCH GLASS  
UNTIL COOLED**

**NEVER ALLOW CHILDREN  
TO TOUCH GLASS**

A barrier designed to reduce the risk of burns from the hot viewing glass is provided with this appliance and must be installed for the protection of children and other at risk individuals.

**CAUTION:**  
HOT WHILE IN OPERATION. DO NOT TOUCH.  
SEVERE BURNS MAY RESULT. KEEP CHILDREN, CLOTHING, FURNITURE,  
GASOLINE, AND ANY OTHER LIQUIDS WITH FLAMMABLE VAPOURS AWAY.

KEEP BURNER AND CONTROL COMPARTMENT CLEAN.  
SEE INSTALLATION AND OPERATING INSTRUCTIONS ACCOMPANYING  
APPLIANCE.

920-408



**NATIONAL  
FIREPLACE  
INSTITUTE**  
**CERTIFIED**  
www.nficertified.org

We recommend that our products be installed and serviced by professionals who are certified in the U.S. by the National Fireplace Institute® (NFI) or in Canada by Wood Energy Technical Training (WETT).



*Wood Energy  
Technical Training*  
www.wett.org

**This product may be installed in an aftermarket, permanently located, manufacture home (USA only) or mobile home, where not prohibited by local codes.**

**This appliance is only for use with the type of gas indicated on the rating plate. This appliance is not convertible for use with other gases, unless a certified kit is used.**

## OWNER'S INFORMATION

Copy of Safety Label HRI3E-11 / .....	7
Copy of Safety Label LRI3E-11 .....	8
MA Code - CO Detector.....	9
Important Message .....	12
Before You Start.....	12
Important Message .....	12
For Your Safety .....	12
Specifications.....	12
Lighting Procedure .....	13
Shutdown Procedure .....	13
Copy Of Lighting Instruction Plate .....	14
Proflame II Remote Control Operating Instructions ....	15

<b>Warranty .....</b>	<b>62</b>
-----------------------	-----------

## INSTALLER'S INFORMATION

### Dimensions

Unit dimensions with Vignette Faceplate .....	4
Unit dimensions with Vignette Faceplate + Small Backing Plate .....	4
Unit dimensions with 4 sided Vignette Faceplate + Backing Plate .....	5
Unit Dimensions with Arched Vignette Faceplate.....	6
Unit Dimensions with Arched Vignette Faceplate + Backing Plate .....	6

### Installation

Gas Installation Checklist .....	10
Gas Pressure Testing .....	18
Installation Into A Solid Fuel Burning Fireplace or Factory Built Fireplace.....	18
Factory-Built (Metal) Wood-Burning Fireplace Requirements.....	18
Installation Checklist.....	19

### On Demand Pilot (seven day safety timer)

#### Important information if using the appliance in CPI (continuous pilot mode) only

This appliance is a ProFlame 2 system fitted with the "On Demand" Pilot, a safety feature which will shut down the gas valve completely by extinguishing the pilot light in the event of a continuous full seven days of inactivity.

This only applies if the CPI (continuous pilot) switch is in the "on" position in your remote control transmitter.

Each time the main burner shuts down, manually or through the call from the thermostat, the seven day timer starts again.

The seven day inactivity timer is controlled within the circuit board. Therefore, if in CPI mode and when the pilot light is extinguished after seven straight days of inactivity, the CPI setting on the remote control transmitter will remain in the "CPI" (continuous pilot) position. Therefore, all that is required to relight the pilot would be to press the on/off button on the remote control transmitter from "on" to "off" and back to "on". Once the pilot has re-established operation will resume as normal. There is no requirement to do anything with the IPI/CPI mode on the remote control transmitter.

If the unit never goes as long as seven full days without a call for heat, the pilot will remain lit until it is manually shut-off.

If the unit is being operated in IPI (intermittent pilot) mode, neither the above instructions nor the seven day timer will apply.

See the instructions in this manual and on the Lighting Instructions plate on the appliance to light or re-light the pilot.

Materials Required.....	19
Minimum Fireplace Dimensions.....	19
Hardwire Kit Installation .....	20
Minimum Clearances to Combustibles .....	23
Gas Connection.....	25
Alternate Approved Caps/Adaptor .....	25
Standing Pilot .....	25
Vent Restrictor Plate Installation.....	25
Flue / Vent Installation .....	26
Air Shutter Adjustment .....	27
Wiring Diagram with fan (LRI3E-11 / HRI3E-11).....	28
System Data .....	29
High Elevation.....	29
Gas Line Installation .....	29
Pilot Adjustment.....	29
Gas Pipe Pressure Testing .....	29
885 S.I.T. Valve Description.....	29
Conversion from NG to LP .....	30
Media Installation.....	32
HRI3E-11 Optional Log Set Installation .....	33
LRI3E-11 Log Set Installation .....	35
Brick Panel Installation .....	37
Painted Black and Enamel Panel Installation .....	38
Glass Door Removal / Installation .....	39
Vignette Faceplate with Safety Screen Installation .....	40
Inlay Installation .....	41
Backing Plate Installation.....	43
Optional Arched Vignette Faceplate Installation .....	44
Optional Backing Plate Installation.....	45
Optional Hearth Trim Installation.....	46
Optional Mantel Deflector Installation .....	46

### Operating Instructions

First Fire.....	47
Operating Instructions .....	47

### Maintenance

Normal Operating Sounds of Gas Appliances .....	48
Maintenance Instructions .....	48
Door Glass .....	49
Glass Replacement .....	49
Pilot Adjustment.....	50
General Vent Maintenance .....	50
Log Replacement .....	50
Glass Gasket .....	50
Backup Battery Pack.....	50
Fan Replacement - with Remote Control.....	51
Valve Replacement .....	52
Gas Maintenance.....	53

### Parts

LRI3E-11 Parts List.....	55
LRI3E-11 Main Assembly.....	56
HRI3E-11 Parts List .....	57
HRI3E-11 Main Assembly .....	58
Accessories .....	59

<b>Warranty .....</b>	<b>60</b>
<b>Recycling .....</b>	<b>65</b>

# dimensions

## UNIT DIMENSIONS WITH VIGNETTE FACEPLATE

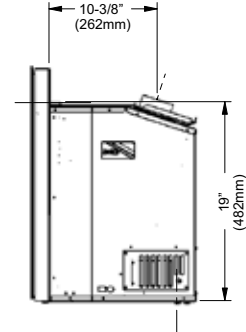
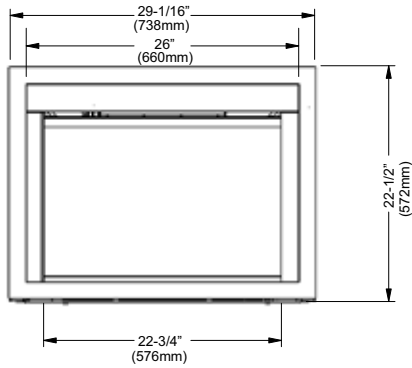
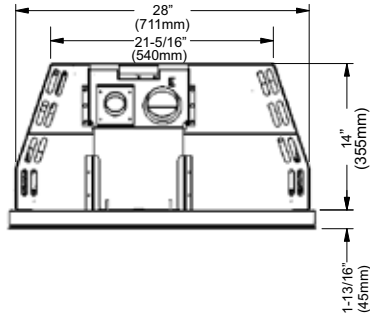

## UNIT DIMENSIONS WITH VIGNETTE FACEPLATE + SMALL BACKING PLATE

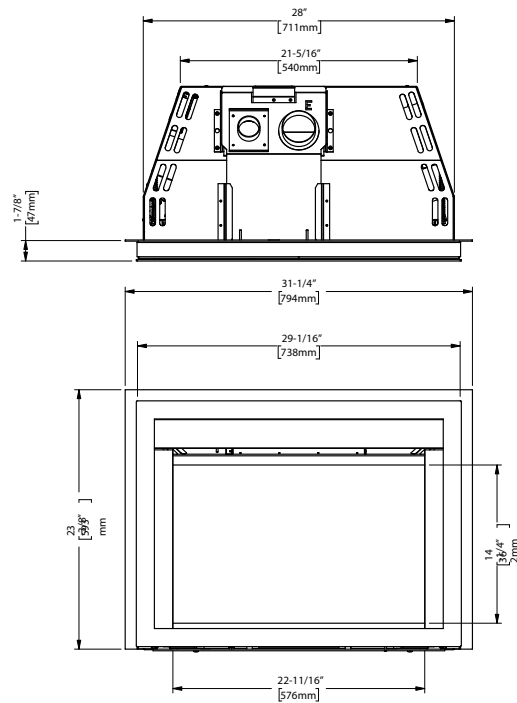

Not Shown:

Regular backing plate - 35-3/4" W x 25-5/8" H

Oversize backing plate - 38-3/16" W x 29-5/8" H

**UNIT DIMENSIONS WITH 4 SIDED VIGNETTE FACEPLATE + BACKING PLATE**

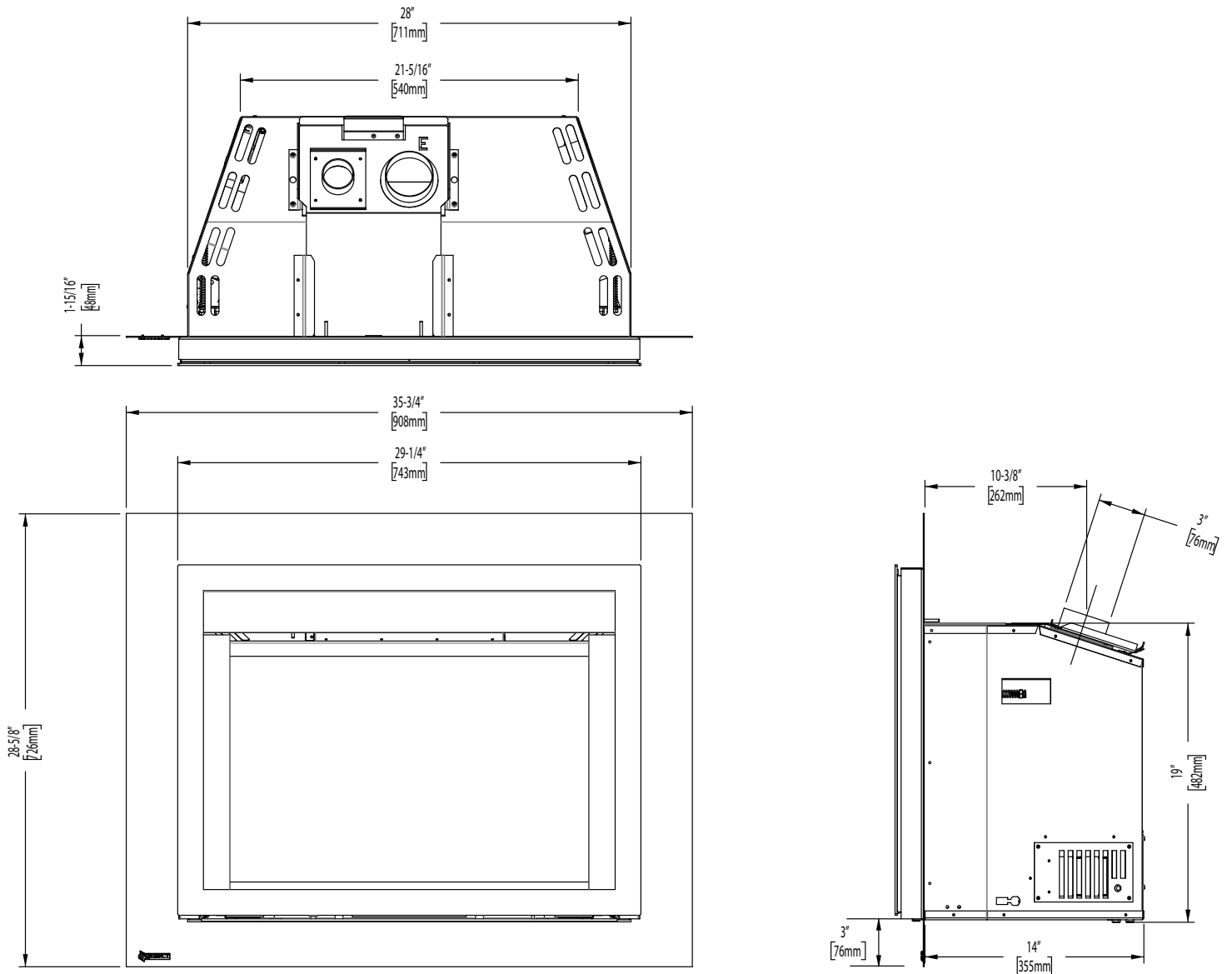

**ALL PICTURES / DIAGRAMS SHOWN THROUGHOUT THIS MANUAL ARE FOR ILLUSTRATION PURPOSES ONLY. ACTUAL PRODUCT MAY VARY DUE TO PRODUCT ENHANCEMENTS.**

# dimensions

## UNIT DIMENSIONS WITH ARCHED VIGNETTE FACEPLATE

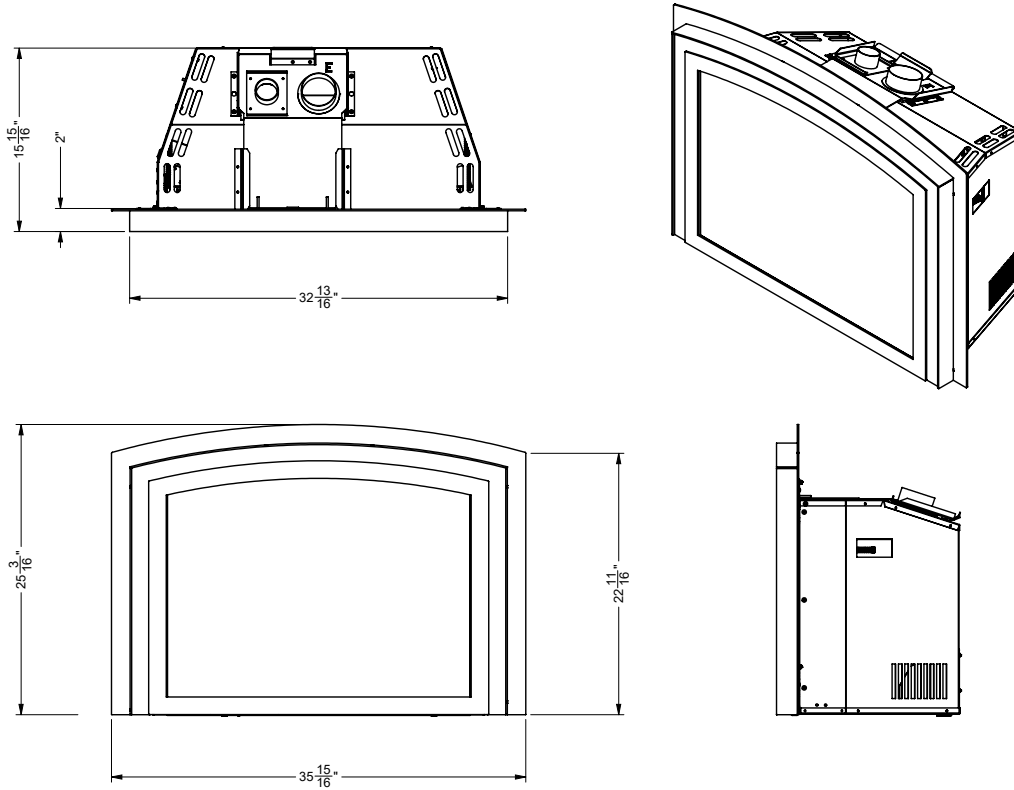



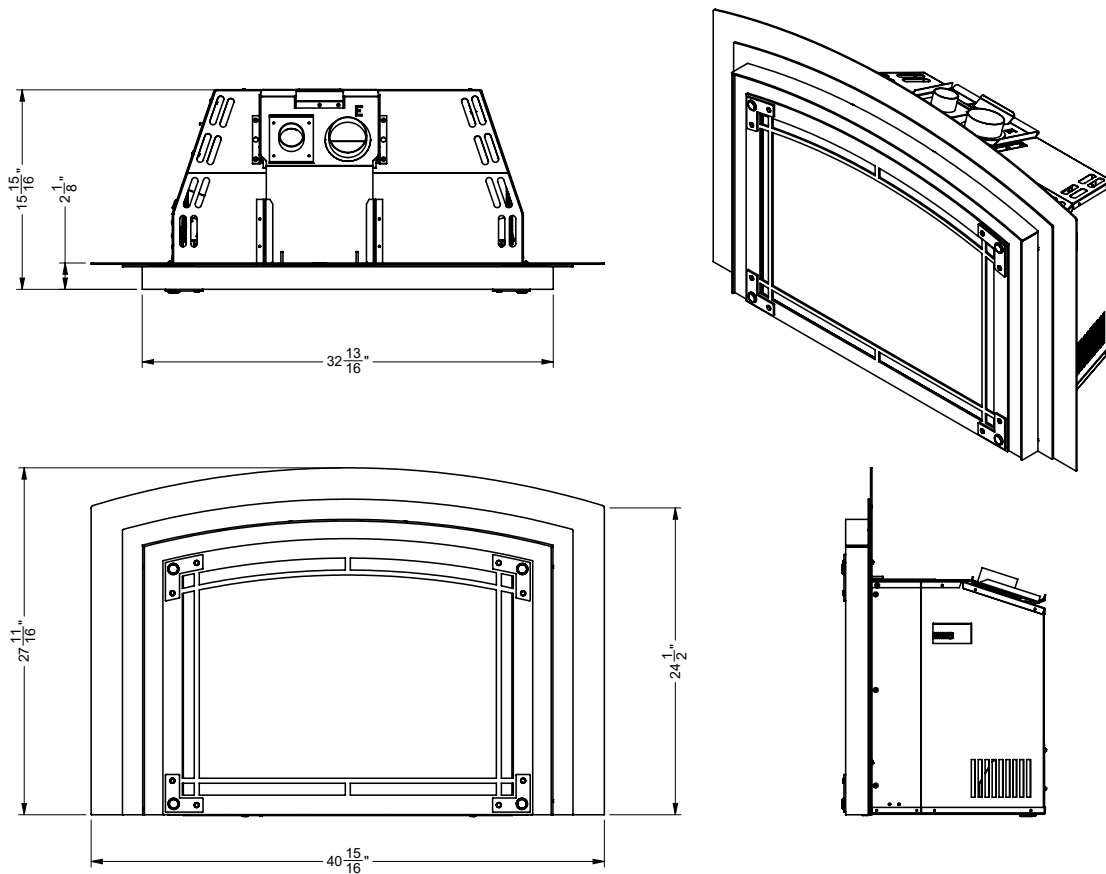

## UNIT DIMENSIONS WITH ARCHED VIGNETTE FACEPLATE + BACKING PLATE

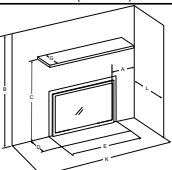

**COPY OF SAFETY LABEL HRI3E-11**

This is a copy of the labels that accompany each HRI3E-11 Gas Insert. We have printed a copy of the contents here for your review.

**NOTE:** Regency units are constantly being improved. Check the label on the unit and if there is a difference, the label on the unit is the correct one.

Duplicate Serial number/Copie No de série		<b>487</b>
	Listed: VENTED GAS FIREPLACE HEATER/FOYER AU GAZ À ÉVACUATION <b>DO NOT REMOVE THIS LABEL / NE PAS ENLEVER CETTE ÉTIQUETTE</b> Certified to/Certifié pour : CSA 2.17-2017 ANSI Z21.88:2019 CSA 2.33:2019	
	<b>487</b>	
Intertek Refer to Intertek's Directory of Building Products for detailed information. Serial No. / No de série C # 4001172 Pour plus de détails, se reporter au Répertoire des produits de construction de Intertek.		
Model/Modèle HRI3E-NG11	<b>NATURAL GAS FIREPLACE INSERT: MODEL HRI3E-NG11</b> <b>Factory Equipped For Altitude 0-4500ft. (0-1370m)</b>	<b>ENCASTRABLE AU GAZ NATUREL</b> <b>MODELE HRI3E-NG11</b>
	Min. supply pressure 5" WC (1.25 kpa) Low Setting Man. pressure 1.6" WC (0.40 kpa) Max. Manifold pressure 3.5" WC (0.87 kpa) Orifice size #45 DMS Minimum input 14,000 Btu/h (4.10 kW) Maximum input 19,500 Btu/h (5.71 kW)	Pression d'alimentation minimale Pression de sortie (manifold) - basse Pression de sortie (manifold) - max. Taille de l'orifice Débit calorifique minimal Débit calorifique maximal
Model/Modèle HRI3E-LP11	<b>PROPANE GAS FIREPLACE INSERT: MODEL HRI3E-LP11</b> <b>Factory Equipped For Altitude 0-4500ft. (0-1370m)</b>	<b>ENCASTRABLE AU GAZ PROPANE</b> <b>MODELE HRI3E-LP11</b>
	Min. supply pressure 11" WC (2.73 kpa) Low Setting Man. pressure 6.4" WC (1.59 kpa) Max. Manifold pressure 10" WC (2.49 kpa) Orifice size #55 DMS Minimum input 15,500 Btu/h (4.54 kW) Maximum input 19,000 Btu/h (5.57 kW)	Pression d'alimentation minimale Pression de sortie (manifold) - basse Pression de sortie (manifold) - max. Taille de l'orifice Débit calorifique minimal Débit calorifique maximal
<b>Minimum Clearances to Combustibles from Insert/Dégagements min. combustibles</b>		<b>Mantel Clearances / Dégagements manteau</b> Min. Hearth Depth/ Prof. min.âtre D 12" (305mm) Min. Hearth Width/ Largeur min.âtre E 36" (914mm) Max. Mantle Depth/ Prof. max. manteau G 12" (305mm)
FPI Fireplace Products International, Ltd Delta BC, CANADA		
		
<b>MADE IN CANADA / FABRIQUÉ AU CANADA</b>		
This appliance must be installed in accordance with local codes, if any; if none, follow the National Fuel Gas Code, ANSI Z223.1, or Natural Gas and Propane Installation Code, CSA B149.1. This appliance is only for use with the type of gas indicated on the rating plate. This appliance is not convertible for use with other gases unless a certified kit is used. This appliance is only for use with the type of gas indicated on the rating plate and may be installed in an aftermarket, permanently located, manufactured (mobile) home where not prohibited by local codes. See owner's manual for details. <b>WARNING:</b> This fireplace has been converted for use with a gas fireplace insert only and cannot be used for burning wood or solid fuels unless all original parts have been replaced, and the fireplace re-approved by the authority having jurisdiction. Cet appareil doit être installé conformément aux codes et règlements locaux, ou, en l'absence de tels règlements, conformément au National Fuel Gas Code ANSI Z223.1, ou au CSA-B149.1 en vigueur. Cet appareil doit être utilisé uniquement avec le type de gaz indiqué sur la plaque signalétique. Cet appareil peut être installé dans une maison préfabriquée ou mobile (E-U, seulement) installée à demeure si les règlements locaux le permettent. Voir la notice de l'utilisateur pour plus de renseignements. Cet appareil ne peut pas être utilisé avec d'autres gaz sauf si une trousse de conversion certifiée est fournie. Cet appareil n'est pas convertible pour une utilisation avec d'autres gaz, sauf si un kit certifié est utilisé. AVERTISSEMENT : Ce foyer a été converti pour être utilisé avec un foyer au gaz encastrable et ne peut être utilisé pour brûler du bois ou d'autres combustibles solides à moins que toutes les pièces d'origine aient été remises en place et que le foyer ait été homologué de nouveau par une autorité compétente. <b>This vented gas fireplace heater is not for use with air filters. For use with glass doors certified with the appliance only. For use only with barrier (Part #716-010) Follow installation instructions.</b> <b>Ne pas utiliser de filtre à air avec ce foyer au gaz à évacuation.</b> Pour utilisation uniquement avec les portes en verre certifiées avec l'appareil. Pour utilisation uniquement avec l'écran (Pièce n°716-010) Suivre les consignes d'installation.		
Electrical supply / Alimentation électrique 115VAC, 2.5 A, 60Hz, Less than 10A Fan Part # 911-207/Pièce ventilateur <b>VENTED GAS FIREPLACE HEATER - NOT FOR USE WITH SOLID FUELS. CATEGORY I.</b> <b>FOYER AU GAZ À ÉVACUATION - NE PAS UTILISER AVEC UN COMBUSTIBLE SOLIDE. CATÉGORIE I.</b>		
	CSA P.4.1 Fireplace Efficiency (FE) /Efficacité énergétique des foyers (EEF) CSA P.4.1 Natural Gas / Gaz naturel 64.36% Propane Gas / Gaz propane 66.24%	
	919-949b	

**DECAL LOCATION**

For the State of Massachusetts, installation and repair must be done by a plumber or gasfitter licensed in the Commonwealth of Massachusetts.

For the State of Massachusetts, flexible connectors shall not exceed 36 inches in length.

For the State of Massachusetts, the appliances individual manual shut-off must be a t-handle type valve.

The State of Massachusetts requires the installation of a carbon monoxide alarm in accordance with NFPA 720 and a CO alarm with battery back up in the same room where the gas appliance is installed.



Remove faceplate from front of unit (see manual)  
 Once the faceplate is removed the rating plate will be located below the glass (see picture).

**DO NOT REMOVE THE DECAL FROM THE UNIT**







# safety decal

## COPY OF SAFETY LABEL LRI3E-11

This is a copy of the labels that accompany each LRI3E-11 Gas Insert. We have printed a copy of the contents here for your review.

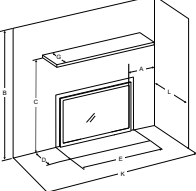
**NOTE:** Regency units are constantly being improved. Check the label on the unit and if there is a difference, the label on the unit is the correct one.

Duplicate Serial number/Copie No de série		488
 <b>ETL</b> <small>CERTIFIED</small> C # 4001172 Intertek Refer to Intertek's Directory of Building Products for detailed information. Pour plus de détails, se reporter au Répertoire des produits de construction de Intertek.	Listed: VENTED GAS FIREPLACE HEATER/FOYER AU GAZ À ÉVACUATION Certified to/Certifié pour : CSA 2.17-2017 ANSI Z21.88:2019 CSA 2.33:2019	
	DO NOT REMOVE THIS LABEL / NE PAS ENLEVER CETTE ÉTIQUETTE	
 Model/Modèle: LRI3E-NG11	<b>NATURAL GAS FIREPLACE INSERT: MODEL LRI3E-NG11</b> <b>Factory Equipped For Altitude 0-4500ft. (0-1370m)</b> Min. supply pressure 5" WC (1.37 kpa) Low Setting Man. pressure 1.6" WC (0.40 kpa) Max. Manifold pressure 3.5" WC (0.87 kpa) Orifice size #45 DMS Minimum input 14,000 Btu/h (4.10 kW) Maximum input 20,500 Btu/h (6.00 kW)	<b>ENCASTRABLE AU GAZ NATUREL</b> <b>MODÈLE LRI3E-NG11</b> Pression d'alimentation minimale Pression de sortie (manifold) - basse Pression de sortie (manifold) - max. Taille de l'orifice Débit calorifique minimal Débit calorifique maximal
 Model/Modèle: LRI3E-LP11	<b>PROPANE GAS FIREPLACE INSERT: MODEL LRI3E-LP11</b> <b>Factory Equipped For Altitude 0-4500ft. (0-1370m)</b> Min. supply pressure 11" WC (2.73 kpa) Low Setting Man. pressure 6.4" WC (1.59 kpa) Max. Manifold pressure 10" WC (2.49 kpa) Orifice size #55 DMS Minimum input 15,500 Btu/h (4.54 kW) Maximum input 19,000 Btu/h (5.57 kW)	<b>ENCASTRABLE AU GAZ PROPANE</b> <b>MODÈLE LRI3E-LP11</b> Pression d'alimentation minimale Pression de sortie (manifold) - basse Pression de sortie (manifold) - max. Taille de l'orifice Débit calorifique minimal Débit calorifique maximal
<b>Minimum Clearances to Combustibles from Insert/Dégagements min. combustibles</b>		
Side wall/mur latéral A 6" (152mm) Ceiling/Plafond B 60" (1524mm) Mantel/Manteau C 38" (965mm) Min. Alcove Width/ Largeur min. alcôve K 54" (1372mm) Max. Alcove Depth/ Prof. max. alcôve L 36" (914mm)		<b>Mantel Clearances / Dégagements manteau</b> Min. Hearth Depth / Prof. min.âtre D 12" (305mm) Min. Hearth Width/ Largeur min.âtre E 36" (914mm) Max. Mantle Depth/ Prof. max. manteau G 12" (305mm)
<b>FPI Fireplace Products International, Ltd</b> <b>Delta BC, CANADA</b>		
This appliance must be installed in accordance with local codes, if any; if none, follow the National Fuel Gas Code, ANSI Z223.1, or Natural Gas and Propane Installation Code, CSA B149.1. This appliance is only for use with the type of gas indicated on the rating plate. This appliance is not convertible for use with other gases unless a certified kit is used. This appliance is only for use with the type of gas indicated on the rating plate and may be installed in an aftermarket, permanently located, manufactured (mobile) home where not prohibited by local codes. See owner's manual for details. <b>WARNING:</b> This fireplace has been converted for use with a gas fireplace insert only and cannot be used for burning wood or solid fuels unless all original parts have been replaced, and the fireplace re-approved by the authority having jurisdiction. Cet appareil doit être installé conformément aux codes et règlements locaux, ou, en l'absence de tels règlements, conformément au National Fuel Gas Code ANSI Z223.1, ou au CSA-B149.1 en vigueur. Cet appareil doit être utilisé uniquement avec le type de gaz indiqué sur la plaque signalétique. Cet appareil peut être installé dans une maison préfabriquée ou mobile (E.-U. seulement) installée à demeure si les règlements locaux le permettent. Voir la notice de l'utilisateur pour plus de renseignements. Cet appareil ne peut pas être utilisé avec d'autres gaz sauf si une trousse de conversion certifiée est fournie. Cet appareil n'est pas convertible pour une utilisation avec d'autres gaz, sauf si un kit certifié est utilisé. <b>AVERTISSEMENT :</b> Ce foyer a été converti pour être utilisé avec un foyer au gaz encastrable et ne peut être utilisé pour brûler du bois ou d'autres combustibles solides à moins que toutes les pièces d'origine aient été remises en place et que le foyer ait été homologué de nouveau par une autorité compétente. <b>This vented gas fireplace heater is not for use with air filters.</b> Ne pas utiliser de filtre à air avec ce foyer au gaz à évacuation. For use with glass doors certified with the appliance only. Pour utilisation uniquement avec les portes en verre certifiées avec l'appareil. For use only with barrier (Part # 716-010) Follow installation instructions. Pour utilisation uniquement avec l'écran (Pièce n°716-010) Suivre les consignes d'installation.		
Electrical supply / Alimentation électrique 115VAC, 2.5 A, 60Hz, Less than 10A Fan Part # 911-207/Pièce ventilateur <b>VENTED GAS FIREPLACE HEATER - NOT FOR USE WITH SOLID FUELS.</b> <b>CATEGORY I. / Foyer au gaz à évacuation - NE PAS UTILISER AVEC UN COMBUSTIBLE SOLIDE. CATÉGORIE I.</b>		
 CANADIAN ENERGY PERFORMANCE VERIFIED Intertek EP5011169 RENDUEMENT ÉNERGÉTIQUE VÉRIFIÉ		CSA P.4.1 Fireplace Efficiency (FE) /Efficacité énergétique des foyers (EEF) CSA P.4.1 Natural Gas / Gaz naturel 66.25% Propane Gas / Gaz propane 66.70%
919-950b		

For the State of Massachusetts, installation and repair must be done by a plumber or gas fitter licensed in the Commonwealth of Massachusetts.

For the State of Massachusetts, flexible connectors shall not exceed 36 inches in length.

For the State of Massachusetts, the appliances individual manual shut-off must be a t-handle type valve.

The State of Massachusetts requires the installation of a carbon monoxide alarm in accordance with NFPA 720 and a CO alarm with battery back up in the same room where the gas appliance is installed.



## MA Code - CO Detector (for the State of Massachusetts only)

### 5.08: Modifications to NFPA-54, Chapter 10

(2) Revise 10.8.3 by adding the following additional requirements:

(a) For all side wall horizontally vented gas fueled equipment installed in every dwelling, building or structure used in whole or in part for residential purposes, including those owned or operated by the Commonwealth and where the side wall exhaust vent termination is less than seven (7) feet above finished grade in the area of the venting, including but not limited to decks and porches, the following requirements shall be satisfied:

1. **INSTALLATION OF CARBON MONOXIDE DETECTORS.** At the time of installation of the side wall horizontal vented gas fueled equipment, the installing plumber or gasfitter shall observe that a hard wired carbon monoxide detector with an alarm and battery back-up is installed on the floor level where the gas equipment is to be installed. In addition, the installing plumber or gasfitter shall observe that a battery operated or hard wired carbon monoxide detector with an alarm is installed on each additional level of the dwelling, building or structure served by the side wall horizontal vented gas fueled equipment. It shall be the responsibility of the property owner to secure the services of qualified licensed professionals for the installation of hard wired carbon monoxide detectors

a. In the event that the side wall horizontally vented gas fueled equipment is installed in a crawl space or an attic, the hard wired carbon monoxide detector with alarm and battery back-up may be installed on the next adjacent floor level.

b. In the event that the requirements of this subdivision can not be met at the time of completion of installation, the owner shall have a period of thirty (30) days to comply with the above requirements; provided, however, that during said thirty (30) day period, a battery operated carbon monoxide detector with an alarm shall be installed.

2. **APPROVED CARBON MONOXIDE DETECTORS.** Each carbon monoxide detector as required in accordance with the above provisions shall comply with NFPA 720 and be ANSI/UL 2034 listed and IAS certified.

3. **SIGNAGE.** A metal or plastic identification plate shall be permanently mounted to the exterior of the building at a minimum height of eight (8) feet above grade directly in line with the exhaust vent terminal for the horizontally vented gas fueled heating appliance or equipment. The sign shall read, in print size no less than one-half (1/2) inch in size, "**GAS VENT DIRECTLY BELOW. KEEP CLEAR OF ALL OBSTRUCTIONS**".

4. **INSPECTION.** The state or local gas inspector of the side wall horizontally vented gas fueled equipment shall not approve the installation unless, upon inspection, the inspector observes carbon monoxide detectors and signage installed in accordance with the provisions of 248 CMR 5.08(2)(a)1 through 4.

(b) **EXEMPTIONS:** The following equipment is exempt from 248 CMR 5.08(2)(a)1 through 4:

1. The equipment listed in Chapter 10 entitled "Equipment Not Required To Be Vented" in the most current edition of NFPA 54 as adopted by the Board; and

2. Product Approved side wall horizontally vented gas fueled equipment installed in a room or structure separate from the dwelling, building or structure used in whole or in part for residential purposes.

(c) **MANUFACTURER REQUIREMENTS - GAS EQUIPMENT VENTING SYSTEM PROVIDED.** When the manufacturer of Product Approved side wall horizontally vented gas equipment provides a venting system design or venting system components with the equipment, the instructions provided by the manufacturer for installation of the equipment and the venting system shall include:

1. Detailed instructions for the installation of the venting system design or the venting system components; and

2. A complete parts list for the venting system design or venting system.

(d) **MANUFACTURER REQUIREMENTS - GAS EQUIPMENT VENTING SYSTEM NOT PROVIDED.** When the manufacturer of a Product Approved side wall horizontally vented gas fueled equipment does not provide the parts for venting the flue gases, but identifies "special venting systems", the following requirements shall be satisfied by the manufacturer:

1. The referenced "special venting system" instructions shall be included with the appliance or equipment installation instructions; and

2. The "special venting systems" shall be Product Approved by the Board, and the instructions for that system shall include a parts list and detailed installation instructions.

(e) A copy of all installation instructions for all Product Approved side wall horizontally vented gas fueled equipment, all venting instructions, all parts lists for venting instructions, and/or all venting design instructions shall remain with the appliance or equipment at the completion of the installation.

# dimensions

## GAS INSTALLATION CHECKLIST

This general checklist does not contain all pertinent installation details or specifics and does not supersede the guidelines in this manual. Your Regency dealer/installer should use it in conjunction with manual instructions. Please follow all local codes and jurisdictions in authority.

<b>Customer:</b> _____	<b>Date Installed:</b> _____	
<b>Install Address:</b> _____	<b>Location of Fireplace:</b> _____	
<b>Serial No:</b> _____	<b>Installer:</b> _____	
<b>Model No:</b> _____		
<b>Site Requirements</b>	<b>YES</b>	<b>NO</b>
If applicable, are the insulation, vapour barrier, and drywall present if installed on an outside wall or chase?		
Does the area have a solid continuous base to support the unit?		
Will the area accommodate the size of the appliance and all clearances?		
Are the gas and electrical roughed into the area where the unit is being installed?		
In City & Grandview series cool wall applications, is the chase enclosure sealed to prevent heat from escaping? All hot air from the unit must exit via the mandatory ventilation openings.		
In City & Grandview applications, Is the chase enclosure vented with the mandatory heat ventilation openings? See manual for details.		
If applicable, is the masonry/factory built fireplace in its original condition with no modifications?		
If applicable, have the hearth requirements been met?		
<b>Unit Setup</b>	<b>YES</b>	<b>NO</b>
If applicable, are the standoffs and top nailing flange extensions installed and at the correct depth to accommodate finishing material? See manual for details.		
If applicable, is the fireplace level and secured, meeting framing clearances? See manual for details.		
If applicable, is the unit converted to top or rear vent per manual instructions, and the insulation discarded?		
<b>Venting</b>	<b>YES</b>	<b>NO</b>
Are the venting components approved for the unit installed?		
Does the venting configuration comply with venting diagrams?		
Is venting installed and secured, and are clearances for the vent pipe and termination cap maintained?		
If applicable, was a 1/4" rise maintained for every foot of horizontal run?		
Was the termination installed and sealed?		
Is the direct vent termination at the highest point in the vent assembly?		
If applicable, are both chimney liners continuous from flue collars to termination?		
<b>Electrical and Wiring</b>	<b>YES</b>	<b>NO</b>
Is the appliance connected to the household's 110/120v per local codes? Check local codes for receptacle placement.		
Were the connections in the fireplace tested with a circuit tester?		
Is the appliance properly grounded?		
If applicable, is the supplied electrical/gang box affixed to the wall to facilitate the mounting of the receiver/battery box ?		
If applicable, is all electrical, Ethernet, HDMI, networking, optical, wire/cables, conduits, etc. run through the wood or steel stud work as wires/cables of any kind cannot be exposed directly above or over the fireplace?		
<b>Gas</b>	<b>YES</b>	<b>NO</b>
Does the supply pressure meet the requirements shown on the rating plate?		
Was a conversion performed?		
Was a leak check performed and manifold pressures verified?		

Is the shut-off valve installed and easily accessible to the customer?		
<b>Finishing</b>	<b>YES</b>	<b>NO</b>
If applicable, is only noncombustible material installed in the noncombustible areas?		
Do clearances meet installation and manual requirements?		
Do the mantels and/or projections comply with the installation manual?		
If applicable, was the solid fuel fireplace warning plate installed?		
Is the chase enclosure fully open the full width, height and depth above the fireplace as per the requirements noted in the framing section?		
<b>Appliance Media Setup</b>	<b>YES</b>	<b>NO</b>
Do commands from the remote or wall switch light the pilot and main burner?		
Are the burner media/log set, glass door, and screen installed per instructions in the manual?		
Was the air shutter on the proper setting after running the unit for 20 minutes?		
If applicable, were the surround and trims installed according to the manual?		
Was the operation of the fan, lights (if installed), and flame modulation checked?		
<b>Customer Tutorial and Presentation</b>	<b>YES</b>	<b>NO</b>
Is the customer confident operating the new gas appliance and aware of all the features on the remote?		
Confirm that the rating and lighting plates are attached to the appliance. Do not remove.		
Was the customer informed of the location of the rating and lighting plates?		
Was accessing unit controls in a power outage explained to the customer?		
Are the model and serial numbers and the date of installation of the unit written in the manual and on the checklist?		
Were the warranty and unit registration reviewed with the customer?		
<b>Comments:</b>		

# owner's information

## IMPORTANT MESSAGE

### SAVE THESE INSTRUCTIONS

The LRI3E-11 / HRI3E-11 Gas Inserts must be installed in accordance with these instructions. Carefully read all the instructions in this manual first. Consult the "authority having jurisdiction" to determine the need for a permit prior to starting the installation. It is the responsibility of the installer to ensure this fireplace is installed in compliance with manufacturers instructions and all applicable codes.

### BEFORE YOU START

Safe installation and operation of this appliance requires common sense, however, we are required by the Canadian Safety Standards and ANSI Standards to make you aware of the following:

**INSTALLATION AND REPAIR SHOULD BE DONE BY AN AUTHORIZED SERVICE PERSON. THE APPLIANCE SHOULD BE INSPECTED BEFORE USE AND AT LEAST ANNUALLY BY A PROFESSIONAL SERVICE PERSON. MORE FREQUENT CLEANING MAY BE REQUIRED DUE TO EXCESSIVE LINT FROM CARPETING, BEDDING MATERIAL, ETC. IT IS IMPERATIVE THAT CONTROL COMPARTMENTS, BURNERS AND CIRCULATING AIR PASSAGEWAYS OF THE APPLIANCE BE KEPT CLEAN.**

**DUE TO HIGH TEMPERATURES, THE APPLIANCE SHOULD BE LOCATED OUT OF TRAFFIC AND AWAY FROM FURNITURE AND DRAPERIES.**

**WARNING: FAILURE TO INSTALL THIS APPLIANCE CORRECTLY WILL VOID YOUR WARRANTY AND MAY CAUSE A SERIOUS HOUSE FIRE.**

**CHILDREN AND ADULTS SHOULD BE ALERTED TO THE HAZARDS OF HIGH SURFACE TEMPERATURES, ESPECIALLY THE FIREPLACE GLASS, AND SHOULD STAY AWAY TO AVOID BURNS OR CLOTHING IGNITION.**

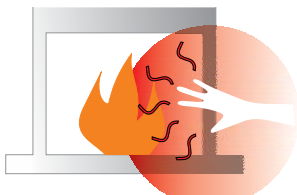

**YOUNG CHILDREN SHOULD BE CAREFULLY SUPERVISED WHEN THEY ARE IN THE SAME AREA AS THE APPLIANCE. TODDLERS, YOUNG CHILDREN AND OTHERS MAY BE SUSCEPTIBLE TO ACCIDENTAL CONTACT BURNS. A PHYSICAL BARRIERS IS RECOMMENDED IF THERE ARE AT RISK INDIVIDUAL IN THE HOUSE. TO RESTRICT ACCESS TO A FIREPLACE OR STOVE, INSTALL AN ADJUSTABLE SAFETY GATE TO KEEP TODDLERS, YOUNG CHILDREN AND OTHER AT RISK INDIVIDUALS OUT OF THE ROOM AND AWAY FROM HOT SURFACES.**

**CLOTHING OR OTHER FLAMMABLE MATERIAL SHOULD NOT BE PLACED ON OR NEAR THE APPLIANCE.**

**A BARRIER DESIGNED TO REDUCE THE RISK OF BURNS FROM THE HOT VIEWING GLASS IS PROVIDED WITH THIS APPLIANCE AND SHALL BE INSTALLED FOR THE PROTECTION OF CHILDREN AND OTHER AT-RISK INDIVIDUALS**

**IF THE BARRIER BECOMES DAMAGED, THE BARRIER SHALL BE REPLACED WITH THE MANUFACTURER'S BARRIER FOR THIS APPLIANCE.**

**ANY SAFETY SCREEN, GUARD, OR BARRIER REMOVED FOR SERVICING AN APPLIANCE MUST BE REPLACED PRIOR TO OPERATING THE APPLIANCE.**

## IMPORTANT MESSAGE SAVE THESE INSTRUCTIONS

The Regency Gas Insert must be installed in accordance with these instructions. Carefully read all the instructions in this manual first. Consult the building authority having jurisdiction to determine the need for a permit prior to starting the installation.

**NOTE:** Failure to follow the instructions could cause a malfunction of the heater which could result in death, serious bodily injury, and/or property damage. Failure to follow these instructions may also void your fire insurance and/or warranty.

**WARNING: Cancer and Reproductive Harm**  
[www.P65Warnings.ca.gov](http://www.P65Warnings.ca.gov)

## FOR YOUR SAFETY

This appliance requires air for proper combustion. Always provide adequate combustion and ventilation air. Follow instructions and information in CSA B149.1 (in Canada) or the National Fuel Gas Code ANSI Z223.1 (in the USA), regarding requirements for combustion and ventilation air.

## SPECIFICATIONS

At pressures over 1/2 psig, the pipe to the unit must be disconnected.

### Gas Max. Input Capacity:

Natural Gas	HRI3E 19,500 Btu/h
	LRI3E 20,500 Btu/h
Propane	HRI3E 19,000 Btu/h
	LRI3E 19,000 Btu/h

### Min. Input

Natural Gas	HRI3E 14,000 Btu/h
	LRI3E 14,000 Btu/h
Propane	HRI3E 15,500 Btu/h
	LRI3E 15,500 Btu/h

**Fuels:** Approved for use with both natural gas, and propane. Approved as is for use at 0' to 4,500' (0-1370m).

**Electrical:** 120V A.C. system.

**Circulation Fan:** Variable speed, 140 CFM.

**Log Set:** Ceramic fibre, 7 per set - LRI3E

**Glass Crystals:** 4lbs of glass crystals - HRI3E

**Optional Log Set:** Ceramic fibre, 5 per set + 4lbs of glass crystals - HRI3E

**Vent System:** 2" intake with 3" exhaust.  
The efficiency rating of the appliance is a product thermal efficiency rating determined under continuous operating conditions and was determined independent of any installed system.

## LIGHTING PROCEDURE

**IMPORTANT:** The remote control system supplied with this appliance has several options for starting/operating the appliance using the battery holder and ON/OFF key on the hand held transmitter.

Prior to operating this appliance, please read the remote control operating instructions (packaged with remote control) to understand how to operate this remote control system.

1. Ensure the battery holder switch is in the Remote position and / or wall mounted battery holder (if equipped) is in the <REMOTE> position.
2. Press and release the ON/OFF button on the remote handheld transmitter (see Diagram 1). An audible beep should be heard from the receiver. If not using the remote, the unit can also be turned on by sliding the battery holder switch to the <ON> position (if equipped).



Diagram 1

Remote shown in Manual Mode on Hi

3. After approximately 4 seconds the spark ignition system will spark for 60 seconds to light the pilot.
4. The unit will turn on.



**Note:** The first try for ignition will last approximately 60 seconds. If there is no flame ignition (rectification) the board will stop sparking for approximately 35 seconds. After wait time, the board will start second try for ignition by sparking for approximately 60 seconds. If there is still no positive ignition the board will go into lock out.

The system will need to be reset as follows:

- a) Turn the system off by pressing the ON/OFF button on the remote.
- b) Wait 5 minutes then repeat from step 2.

## SHUTDOWN PROCEDURE

1. Press the ON/OFF button on the remote
2. If service is to be performed- you must disconnect power and shut off gas to the unit.

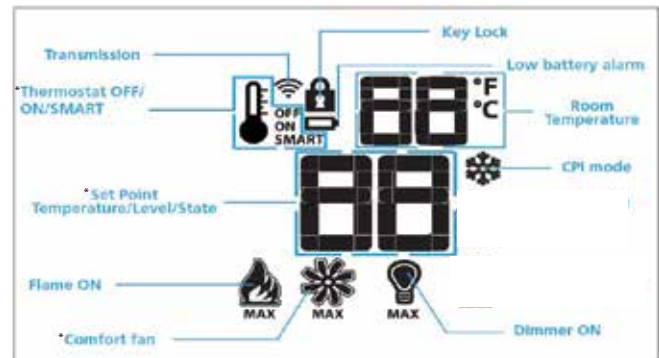

\* Not offered on all models.

**Fan Operation:** The standard fan can be operated by using the remote control supplied with this unit. See remote control instructions.

**Note:** In thermostat mode: When the appliance is turned on, the fan will not come on for the first 5 minutes (if fan is turned on). When the appliance is turned off the fan will not turn off for 12 minutes (if in on position)

**Manual mode:** Fan will turn on and off immediately using the remote control transmitter if the fan function is in the "on" position.

Continuous Pilot/Intermittent Pilot (CPI/IPI) **selection**

See remote control instructions for details.

### On Demand Pilot (seven day safety timer)

**Important information if using the appliance in CPI (continuous pilot mode) only**

This appliance is a ProFlame 2 system fitted with the "On Demand" Pilot, a safety feature which will shut down the gas valve completely by extinguishing the pilot light in the event of a continuous full seven days of inactivity.

This only applies if the CPI (continuous pilot) switch is in the "on" position in your remote control transmitter.

Each time the main burner shuts down, manually or through the call from the thermostat, the seven day timer starts again.

The seven day inactivity timer is controlled within the circuit board. Therefore, if in CPI mode and when the pilot light is extinguished after seven straight days of inactivity, the CPI setting on the remote control transmitter will remain in the "CPI" (continuous pilot) position. Therefore, all that is required to relight the pilot would be to press the on/off button on the remote control transmitter from "on" to "off" and back to "on". Once the pilot has re-established operation will resume as normal. There is no requirement to do anything with the IPI/CPI mode on the remote control transmitter.

If the unit never goes as long as seven full days without a call for heat, the pilot will remain lit until it is manually shut-off.

If the unit is being operated in IPI (intermittent pilot) mode, neither the above instructions nor the seven day timer will apply.

See the instructions in this manual and on the Lighting Instructions plate on the appliance to light or re-light the pilot.

## COPY OF THE LIGHTING PLATE INSTRUCTIONS

**FOR YOUR SAFETY READ BEFORE LIGHTING  
POUR VOTRE SÉCURITÉ – À LIRE AVANT LA MISE EN MARCHÉ**

**WARNING:** If you do not follow these instructions exactly, a fire or explosion may result causing property damage, personal injury or loss of life. Improper installation, adjustment, alteration, service or maintenance can cause injury or property damage. Refer to the owner's information manual provided with this appliance. For assistance or additional information consult a qualified installer, service agency or gas supplier.

**AVERTISSEMENT :** Quiconque ne respecte pas scrupuleusement les instructions de la présente notice risque de déclencher un incendie ou une explosion pouvant entraîner des dégâts matériels ou des blessures pouvant être mortelles.

Tout défaut d'installation, de réglage, de modification, de service ou d'entretien peut entraîner des blessures ou des dommages matériels. Reportez-vous au manuel d'utilisation fourni avec cet équipement. Pour obtenir de l'aide ou des informations complémentaires, consulter un installateur ou un service d'entretien qualifié, ou le fournisseur de gaz.

- A) This appliance is equipped with an ignition device which automatically lights the pilot.  
Do not try to light the pilot by hand.
- B) **BEFORE OPERATING** smell all around the appliance area for gas. Be sure to smell next to the floor because some gas is heavier than air and will settle on the floor.  
**WHAT TO DO IF YOU SMELL GAS**
- Do not try to light any appliance.
  - Do not touch any electric switch, do not use any phone in your building.
  - Leave the building immediately.
  - Immediately call your gas supplier from a neighbours phone. Follow the gas supplier's instructions.
  - If you cannot reach your gas supplier, call the fire department.
- C) Do not use this appliance if any part has been under water. Immediately call a qualified service technician to inspect the appliance and to replace any part of the control system and any gas control which has been underwater.
- A) Cet appareil est muni d'un dispositif d'allumage qui allume automatiquement la veilleuse.  
Ne tentez pas d'allumer la veilleuse manuellement.
- B) **AVANT LA MISE EN MARCHÉ**, reniflez tout autour de l'appareil pour détecter une odeur de gaz. Reniflez au niveau du plancher, car certains gaz sont plus lourds que l'air et peuvent s'accumuler au niveau du sol.
- QUE FAIRE SI VOUS SENTEZ UNE ODEUR DE GAZ :**
- Ne tentez pas d'allumer l'appareil
  - Ne touchez à aucun interrupteur; n'utilisez pas le téléphone se trouvant dans le bâtiment.
  - Quittez immédiatement le bâtiment.
  - Appelez immédiatement votre fournisseur de gaz depuis un téléphone extérieur. Suivez les instructions du fournisseur.
  - Si vous ne pouvez pas rejoindre le fournisseur, appelez le service incendie.
- C) N'utilisez pas cet appareil s'il a été plongé dans l'eau, même partiellement. Faites inspecter l'appareil par un technicien qualifié et remplacez tout élément du système de contrôle ou de commande qui a été plongé dans l'eau.

**CAUTION: Hot while in operation. Do not touch. Severe burns may result. Due to high surface temperatures keep children, clothing and furniture, gasoline and other liquids having flammable vapors away. Keep burner and control compartment clean. See installation and operating instructions accompanying appliance.**

**ATTENTION : Surfaces chaudes lorsque l'appareil est en marche. Ne pas toucher. Risque de brûlures graves. En raison des températures élevées, les enfants, les vêtements et le mobilier, le carburant et tout autre liquide aux vapeurs inflammables doivent être tenus éloignés de l'appareil. Nettoyer régulièrement le brûleur et le compartiment des commandes. Voir les consignes d'installation et d'utilisation fournies avec l'appareil.**

**OPERATING INSTRUCTIONS / CONSIGNES DE FONCTIONNEMENT**

- 1) **STOP!** Read the safety information above on this label.
  - 2) Ensure the Main switch is in the ON position and/or the wall mounted battery holder (if equipped) is in the <REMOTE> position.
  - 3) Press and release the ON/OFF button on the remote handheld transmitter. An audible beep should be heard from the receiver. If not using the remote, the unit can also be turned on by sliding the battery holder switch to the <ON> position (if equipped).
  - 4) After approximately 4 seconds the spark ignition system will spark for 60 seconds to light the main burner.
  - 5) The unit will turn on.  
Note: The first attempt to ignition will last approximately 60 seconds. If there is no flame ignition (rectification) the board will stop sparking for approximately 35 seconds. After this wait time, the board will start a second try for ignition by sparking for approximately 60 seconds. If there is still no positive ignition after the second attempt the board will go into lock out.  
The system will need to be reset as follows (after going into lock out mode):
    - a) Wait 5 minutes - turn the system off by pressing the ON/OFF button on the remote.
    - b) After approximately 2 seconds press the ON/OFF button again.
    - c) Unit will repeat step 2.
  - 6) If the appliance will not operate, follow the instructions, "To Turn Off Gas to Appliance" and call your service technician or gas supplier. This appliance is equipped with an on-demand pilot that shuts off after seven days.
- 1) **STOP!** Lisez les instructions de sécurité sur la portion supérieure de cette étiquette.
  - 2) S'assurer que le commutateur principal est en position ON et/ou que le bloc-piles mural (le cas échéant) est en position <REMOTE>.
  - 3) Appuyer sur la touche ON/OFF de la télécommande puis relâcher. Un bip sonore retentira depuis le récepteur. Si vous n'utilisez pas la télécommande, l'appareil peut également être allumé en faisant glisser le commutateur du bloc-piles sur la position <ON> (le cas échéant).
  - 4) Après environ 4 secondes, le système d'allumage produira une étincelle pendant 60 secondes pour allumer le brûleur principal.
  - 5) L'appareil s'allumera.  
Remarque : Au premier allumage, le système tente d'allumer les flammes pendant 60 secondes. Si l'essai est infructueux, le système fera une pause de 35 secondes. C'est ce qu'on appelle l'étape de rectification. Ce délai écoulé, le système tente à nouveau d'allumer les flammes en produisant des étincelles pendant 60 secondes. Si les flammes ne s'allument toujours pas, le système se met en mode verrouillage.  
Il faut alors le réinitialiser en suivant les étapes ci-dessous (pour le déverrouiller) :
    - a) Attendre 5 minutes et éteindre l'appareil en appuyant sur la touche ON/OFF de la télécommande.
    - b) Attendre 2 secondes et appuyer encore une fois sur la touche ON/OFF.
    - c) L'appareil répètera l'étape 2.
  - 6) Si l'appareil ne fonctionne pas, suivez les instructions "Pour couper le gaz au niveau de l'appareil" et appelez un technicien qualifié ou votre fournisseur de gaz.  
Cet appareil est équipé d'une veilleuse sur demande qui s'éteint après sept jours.

**TO TURN OFF GAS TO APPLIANCE / POUR COUPER LE GAZ AU NIVEAU DE L'APPAREIL**

- 1) Press the ON/OFF button on the remote or slide the wall mount switch to the "OFF" position.
- 1) Appuyer sur la touche ON/OFF de la télécommande ou faites glisser l'interrupteur mural sur la position "OFF".
- 2) If service is to be performed—you must disconnect power and shut off gas to the unit.  
2) Lors de l'entretien de l'appareil, vous devez débrancher l'alimentation électrique et couper le gaz alimentant l'appareil.

**DO NOT REMOVE THIS INSTRUCTION PLATE**

**NE PAS ENLEVER CETTE ÉTIQUETTE D'INSTRUCTIONS**

919-649b

## PROFLAME II REMOTE CONTROL OPERATING INSTRUCTIONS

**IMPORTANT:** The Proflame Transmitter 2 is an integrated part of the Proflame 2 System, which consists of these elements:

- Proflame 2 Transmitter, to be used in conjunction with:
- Integrated Fireplaces Control (Proflame 2 IFC)

The Proflame 2 Transmitter provides for controlling the following hearth appliance functions:

1. Main Burner On/Off
2. Main Burner flame modulation (6 levels)
3. Choice of standing or intermittent pilot (CPI/IPI)
4. Thermostat and Smart thermostat functions
5. Accent light modulation (6 levels)\*\*
6. Split flow valve\*\*
7. Comfort Fan speed modulation (6 levels)\*\*

\*\* This feature is not available on any Hampton models.

The Proflame Transmitter uses a streamline design with a simple button layout and informative LCD display (Fig. 1). A Mode Key is provided to index between the features and a Thermostat Key is used to turn on/off or index through Thermostat functions (Fig. 1 & 2). Additionally, a Key Lock feature is provided (Fig. 22).



Figure 1: Proflame Transmitter

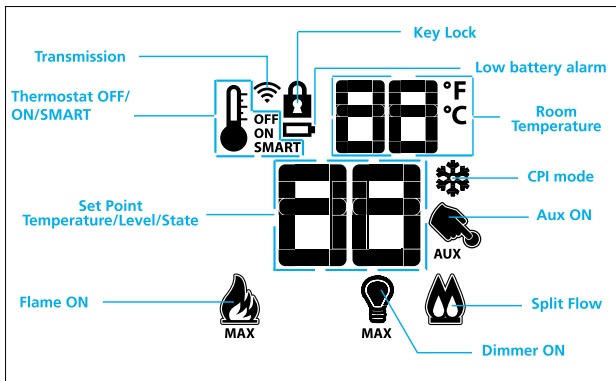

Figure 2: Transmitter LCD Display



TECHNICAL DATA REMOTE CONTROL	
Supply Voltage	4.5V (three 1.5V AAA batteries)
Ambient temperature ratings	0 - 50°C (32 - 122°F)
Radio Frequency	315 MHZ

**WARNING: THE TRANSMITTER AND IFC ARE RADIO FREQUENCY DEVICES.**

### ATTENTION!

- Turn "OFF" the main gas supply of the appliance during installation or maintenance of the IFC.
- Turn "OFF" main gas supply to the appliance prior to removing or reinserting the batteries.
- In case of remote control malfunction, turn off the IFC device using the "ON/OFF" main switch.
- For installation / maintenance, switch off the IFC device removing main power supply plug.

## OPERATING PROCEDURE

### Pairing the remote control to IFC (if required)

Power the IFC. Locate the black reset button on the lower left hand side of the appliance. See this manual for location/instructions. The IFC will "beep" three (3) times to indicate that it is ready to synchronize with a Transmitter. Install the 3 AAA type batteries in the Transmitter battery bay, located on the base of the Transmitter. (fig. 3) With the batteries already installed in the Transmitter, push the On button. The IFC will "beep" four times to indicate the Transmitter's command is accepted and sets to the particular code of that Transmitter. The system is now initialized.

**Note:** Only use regular alkaline batteries. Do not use rechargeable or lithium batteries.



Figure 3: Battery Compartment

### Smart Thermostat (Transmitter Operation)

The Smart Thermostat function adjusts the flame height in accordance to the difference between the set point temperature and the actual room temperatures. As the room temperature gets closer to the set point the Smart Function will modulate the flame down.

To activate this function, press the Thermostat Key (Fig. 1) until the word "SMART" appears to the right of the temperature bulb graphic (Fig. 11). To adjust the set temperature, press the Up or Down Arrow Keys until the desired set temperature is displayed on the LCD screen of the Transmitter (Fig. 12).

Note. When Smart Thermostat is activated, manual flame height adjustment is disabled.

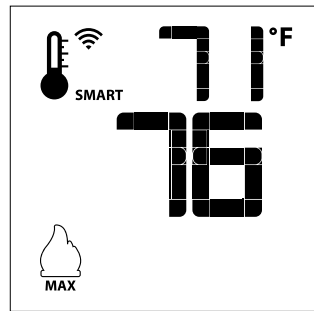

Figure 11: Smart Flame Function

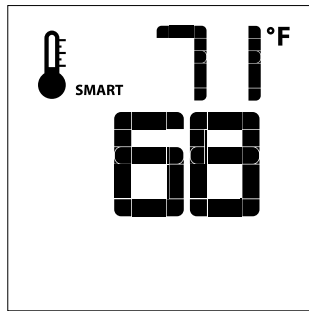

Figure 12

### Fan Speed Control\*\*

If the appliance is equipped with a hot air circulating fan, the speed of the fan can be controlled by the Proflame system. The fan speed can be adjusted through six (6) speeds. To activate this function use the Mode Key (fig.1) to index to the fan control icon (Fig. 13). Use the Up/Down Arrow Keys (fig.1) to turn on, off or adjust the fan speed (fig. 14). A single "beep" will confirm reception of the command.

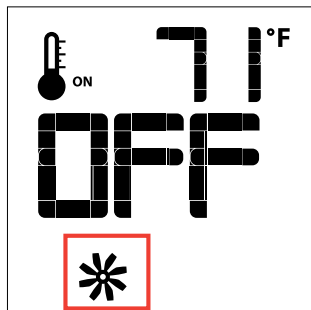

Figure 13

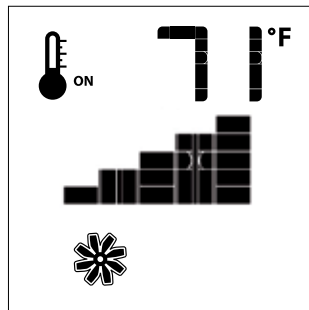

Figure 14

### Remote dimmer control (Light)\*\*

The auxiliary function controls the AUX power outlet by the dimmable light control. To activate this function use the Mode Key (fig. 1) to index to the AUX icon (fig. 15 & 16).

The intensity of the output can be adjusted through six (6) levels. Use the Up/Down Arrow Keys (Fig.1) adjust the output level (Fig. 16). A single "beep" will confirm reception of the command.

**Note:** This function is available only with the IFC Control Module.

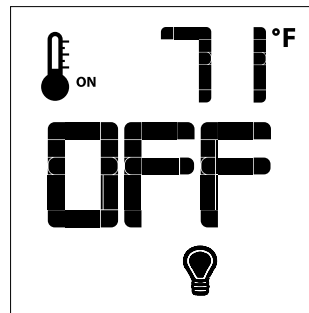

Figure 15

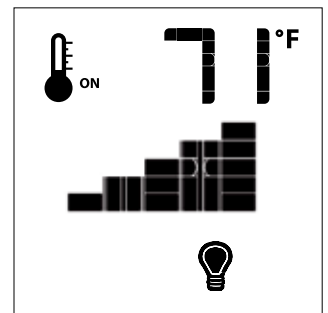

Figure 16

### Split Flow control\*\*

The secondary burner is controlled by the split Flow. To activate this function use the Mode Key (fig. 1) to index to the SPLIT FLOW mode icon (fig. 17 & 18).

Pressing the Up Arrow Key will activate the secondary burner. Pressing the Down Arrow Key will turn the secondary burner off. A single "beep" will confirm the reception of the command.

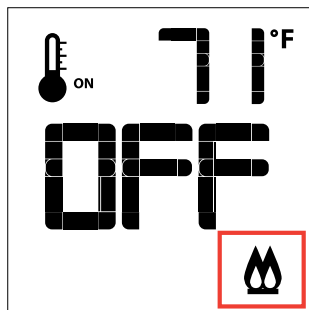

Figure 17

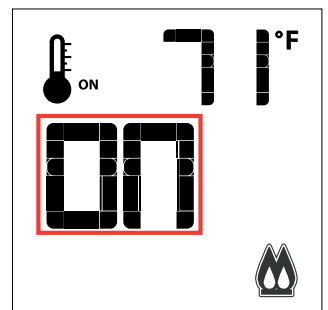

Figure 18



## Continuous Pilot/Intermittent Pilot (CPI/IPI) selection

**Note: Power vent models do not have a Continuous Pilot option.**

With the system in "OFF" position press the Mode Key (fig. 1) to index to the CPI mode icon (fig. 19 & 20). Pressing the Up Arrow Key will activate the Continuous Pilot Ignition mode (CPI). Pressing the Down Arrow Key will return to IPI. A single "beep" will confirm the reception of the command.

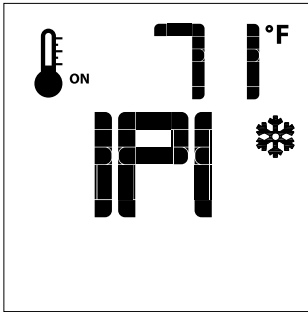

Figure 19

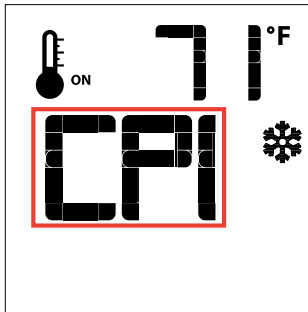

Figure 20

## CPI/IPI SWITCH

This appliance comes equipped with a CPI/IPI switch. The functions of both the CPI/IPI switch are as follows:

**Continuous pilot (CPI)** - A pilot that when in operation, is intended to remain continuously ignited until it is manually interrupted.

**Intermittent pilot (IPI)** - A pilot that is automatically ignited when an appliance is called on to operate and which remains continuously ignited during each period of main burner operation. The pilot is automatically extinguished when each main burner operating cycle is completed. The mode of the fireplace is easily changed from an intermittent pilot ignition system (IPI) to a continuous pilot ignition system (CPI) by using remote control as noted above.

The benefits of having as CPI are as follows:

- Keeps venting primed for trouble free start-up under colder weather conditions or inversions.
  - Keeps the unit glass warm, which decreases the amount of condensation on start-up
  - Provides owners with flexibility to choose a traditional continuous pilot.
- The primary benefit of having the IPI function is a significant savings on fuel as the pilot will only run when there is a call for heat.

**Thermostat Icon:** If the thermostat icon is not present on the remote transmitter, follow instructions noted below:

1. Remove one battery from the remote.
2. Press and hold down the Thermostat button on the remote.
3. Reinstall the battery (removed in Step 1) while still holding down thermostat button.
4. If you see "Set" the thermostat option is now enabled. If you see "Clr" the thermostat option is now disabled.
5. Repeat the procedure if the "Set" or "Clr" to remove or add the option back to the remote did not appear.

Enable all other functions if not present on the remote transmitter, follow instructions noted below:

1. Remove one battery from remote.
2. Press and hold both the **ON/OFF** and **MODE** button at the same time .
3. Reinstall battery removed in Step 1 while holding both buttons—keep holding buttons, then release the **MODE** button only.
4. The screen will show either "Clr" or "Set" as the first option available is to disable or enable a mode.

5. "Clr" will remove a mode—use the up or down arrow while holding down **ON/OFF** and **MODE** (mode icon will disappear once removed).
6. Use the "**MODE**" button to move to the next function.
7. "Set" will add a mode —use the up or down arrow while holding down **ON/OFF** and **MODE** (mode icon will appear when added).
8. Use the "**MODE**" button to move to the next function.

**Note:** You should never program out the fan (if installed) or CPI/IPI mode on the remote.

## KEY LOCK

This function will lock the keys to avoid unsupervised operation. To activate this function, press the MODE and UP Keys at the same time (fig. 21). To de-activate this function, press the MODE and UP Keys at the same time.

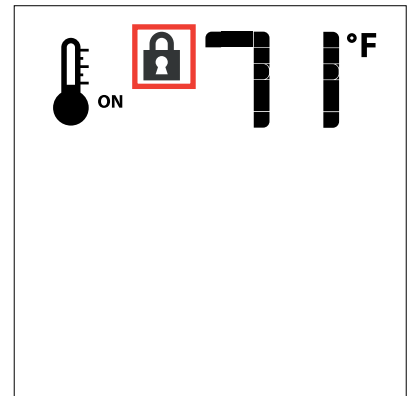

Figure 21

## LOW BATTERY POWER DETECTION

### Transmitter

The life span of the remote control batteries depends on various factors: quality of the batteries used, the number of ignitions of the appliance, the number of changes to the room thermostat set point, etc. When the Transmitter batteries are low, a Battery Icon will appear on the LCD display of the Transmitter (Fig. 22) before all battery power is lost. When the batteries are replaced this Icon will disappear.

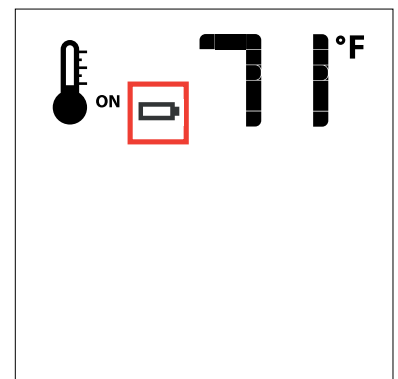

Figure 22

# installation

## GAS PRESSURE TESTING

The appliance must be isolated from the gas supply piping system by closing its individual manual shut off valve during any pressure testing of the gas supply piping system at test pressures equal to or less than 1/2 psig. (3.45 kPa).

## INSTALLATION INTO A SOLID FUEL BURNING FIREPLACE OR FACTORY BUILT FIREPLACE

The LRI3E-11/HRI3E-11 Gas Inserts have been tested and approved to be vented into any masonry fireplace or approved solid fuel burning factory built fireplace that will allow the insert to physically fit into the firebox. Refer to "Minimum Fireplace Dimensions" section for minimum fireplace clearances.

If the factory built fireplace\* height is too low for your Insert, you may remove the smoke baffle plate, damper, refractory (firebricks), glass doors, screen rails, screen mesh and log grates from the factory built fireplace as long as these items are saved and are reinstalled in the event that the Insert is removed. The fireplace flue damper can be fully blocked open or removed for installation of the gas fireplace insert.

Smoke shelves, shields and baffles may be removed if attached by mechanical fasteners. If any part is removed it must not weaken the structural integrity of the factory built fireplace.

The fireplace and fireplace chimney must be clean and in good working order and constructed of non-combustible materials.

The surround panels should not seal ventilation openings on the fireplace.

Chimney clean outs should fit properly.

**NOTE:** Any alterations made to the listed solid fuel burning factory built fireplace may void the listing of the fireplace.

Cutting any sheet metal part of the fireplace, in which the gas fireplace insert is to be installed is prohibited.

\*Check with your local inspector before commencing with this installation.

Installer must mechanically attach the supplied label to the inside of the firebox of the fireplace into which the gas fireplace insert is installed.

**"WARNING:** This fireplace has been converted for use with a gas fireplace insert only and cannot be used for burning wood or solid fuels unless all original parts have been replaced, and the fireplace re-approved by the authority having jurisdiction."

## FACTORY-BUILT (METAL) WOOD-BURNING FIREPLACE REQUIREMENTS

**NOTE:** Any parts that are removed must be removed in a way that would allow them to be re-installed if the insert is ever removed (removal of rivets or screws is acceptable).

To reference parts—see illustration below.

**Must** be removed:

- 1 - Damper
- 2 - Grate (with log set)

May be removed (if applicable):

- 3 - Smoke shelf
- 4 - Internal baffles
- 5 - Screen
- 6 & 7 - Masonry lining or refractory
- 8 - Metal or glass doors

The fireplace must be permanently marked to indicate that it has been altered and is no longer suitable for burning solid fuel (wood), unless the removed parts are re-installed. Cutting of any sheet metal parts is prohibited.

May be removed (in certain cases):

- 9 - Metal floor of the firebox
- 10 - The insulation and any structured rigid frame members must not be removed or altered (side and top of door frame, side and top of the face of the fireplace, metal sides, etc.).

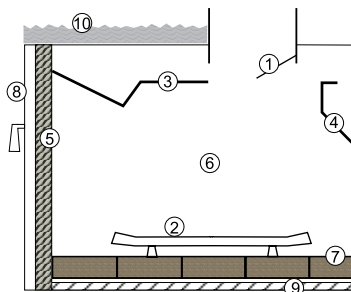

### CAUTION:

Firebox floor removal is not covered under the appliance safety standard (ANSI Z21.88, CSA 2.33) used in the safety certification of this appliance. The Intertek safety certification does not apply to this method of installation. Before installing the appliance using this method, contact the Authority Having Jurisdiction to determine if this installation is acceptable in your area. The sheet metal base of the fireplace must be left in place and a minimum 1/2" cement board sheet placed under the entire length and width of the appliance.

If the factory-built fireplace has no gas access hole(s) provided, an access hole of 1.5 inch (37.5 mm) or less may be drilled through the lower sides or bottom of the firebox in a proper workmanship like manner. This access hole must be plugged with non-combustible insulation after the gas supply line has been installed.

## General Safety Information

1. The appliance installation must conform with local codes or in the absence of local codes, with CSA B149.1 (in Canada) or the National Fuel Gas Code ANSI Z223.1 in the U.S.A. This appliance should be installed by a qualified gas fitter technician only.
2. **Installation and repair should be done by a qualified service person.**
3. The appliance should be inspected before use and at least annually by a professional service person. More frequent cleaning may be required due to excessive lint from carpeting, bedding material, animal hair, etc. It is imperative that control compartments, burners and circulating air passageways of the appliance be kept clean.
4. See general construction and assembly instructions. This appliance may only be installed in a vented, noncombustible fireplace.
5. This appliance is listed for bedroom installations when used with a listed Millivolt Thermostat. Some areas may have further requirements, check local codes before installation.
6. Always connect this insert to a vent system venting to the outside of the building envelope. Never vent to another room or inside a building. Make sure that the vent is properly sized and is of adequate height to provide the proper draft.
7. Inspect the venting system annually for blockage and any signs of deterioration.
8. Any glass removed for servicing must be replaced prior to operating the appliance.
9. To prevent injury, do not allow anyone who is unfamiliar with the operation to use the fireplace.
10. This appliance cannot be operated without brick or enamel panels in place.
11. Due to high temperatures, the appliance should be located out of high traffic areas and away from furniture and draperies. Children and adults should be alerted to the hazards of high surface temperatures, especially the fireplace glass and gold trims, and should stay away to avoid burns or clothing ignition. Young children should be carefully supervised when they are in the same room as the appliance. Clothing or other flammable material should not be placed on or near the appliance.

**WARNING: Failure to position the parts in accordance with the diagrams in this manual or failure to use only parts specifically approved with this appliance may result in property damage or personal injury.**

## INSTALLATION CHECKLIST

Before installing vent system ensure that the damper plate is open and secure to prevent the damper plate from falling down and crushing the liner.

The Regency Gas Insert is installed as listed.

1. Check all clearances to combustibles, (Refer to sections "Minimum Fireplace Dimensions and Clearances to Combustibles")
2. Make the gas connection. (Refer to section "Gas Connection")
3. Install the two liners (2" intake and 3" exhaust) to the sliding connector plate. (Refer to section "Flue Liner Installation.")
4. Slide the unit half way into the fireplace.
5. Pull the vent connector plate through the tapered brackets and fasten to the front plate. Refer to section "Flue Liner Installation."
6. Slide the unit fully into the fireplace. Level if necessary.
7. Hook up 120 volt AC power cord into a suitable receptacle. Optional: Install 4 batteries in the battery pack. Batteries only serve as back up if power is lost within the home.
8. Test gas pressure (Refer to section "Gas Pipe Pressure Testing"). Check aeration system (Refer to section "Gas Insert Aeration System").
9. Install standard and optional features. Refer to the following sections:
  - a. Brick Panels (LRI3E) or Enamel Panels (LRI3E,HRI3E)  
NOTE: Painted panels come with HRI3E. (Panels - must be installed to operate unit)
  - b. Log Set
  - c. Glass Crystals
  - d. Spa stones
  - e. Vignette Faceplate
  - f. Mantel deflector
  - g. Hearth Trim
  - h. Backing plate/4 sided backing plate
10. Final check: Before leaving this unit with the customer, the installer must ensure that the appliance is firing correctly. This includes:
  - a) Clocking the appliance to ensure the correct firing rate.
  - b) Adjusting the primary air, if required, to ensure that the flame does not carbon. See "Gas Insert Aeration System" section.
  - c) Ensuring that the appliance is venting correctly.

## MATERIALS REQUIRED

A 120 Volt AC power cord is hooked up to operate the fan and operate the gas valve when batteries are not installed in the receiver. Plug the 3 wire cord into a suitable receptacle. **Do not cut the ground terminal off under any circumstances.** When connected with 120 volts, the appliance must be electrically grounded in accordance with local codes, current version of CSA C22.1 (in Canada) or in the absence of local codes, with the National Electrical Code ANSI/NFPA 70-1987.

## MINIMUM FIREPLACE DIMENSIONS

The minimum fireplace clearances & dimensions for the Regency gas insert are shown in the following diagrams:

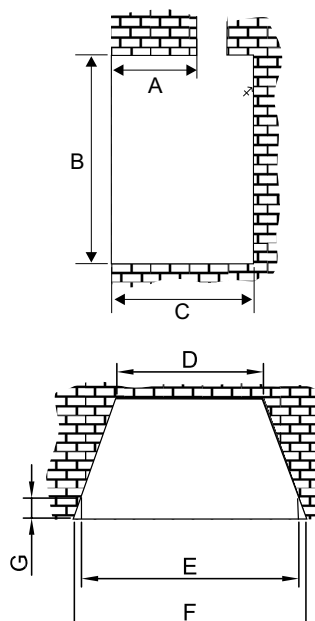

	Max Lintel Bar Depth A	Height B	Depth C	Width (rear) D	Width (front) E	Width F	Front Depth To Taper G
Vignette Faceplate	8-5/8" (219 mm)	19-1/2" (495 mm)	14-1/2" (368 mm)	21-5/8" (549 mm)	28-1/2" (724 mm)	31-1/8" (791 mm)	4" (102 mm)
Arched Vignette Faceplate	8-5/8" (219 mm)	19-1/2" (495 mm)	14-1/2" (368 mm)	21-5/8" (549 mm)	28-5/8" (724 mm)	31-1/8" (791 mm)	4" (102 mm)

# installation

## HARDWIRE KIT INSTALLATION

### IMPORTANT

- Electrical power must be brought to the appliance by a licensed electrician.
- This kit must be installed in accordance with local electrical codes. Consult your local building official for any requirements that must be met in your area.
- Make sure the electrical lead leading to the insert has been disabled prior to installing this kit.

The 946-854 Hardwire Kit contains the following:

	Part #	Description	Qty
1	911-434	Armored Cable - 12/2 AC90 10ft (3m)	1
2	905-114	Adapter Right Angle Zinc 3/8"	1
3	904-687	Connector Clamp 3/8 CI-804	1
4	911-432	Wire Harness Gas Hardwire Kit	1
5	166-451	Hardwire Plate*	1
6	910-199	Clip Wire Holder	1
7	911-252	Twist-On Wire Connector	3
8	911-249	Anti Short Bushing #0 Red	2
9	904-187	Cable Tie Black (CV100W)	1
10	920-833	Instruction Sheet	1

**Shut off the gas and disconnect electrical supply to the unit before beginning.**

Remove safety screen and glass front. See manual.

1. Remove the left control panel cover (5 screws).

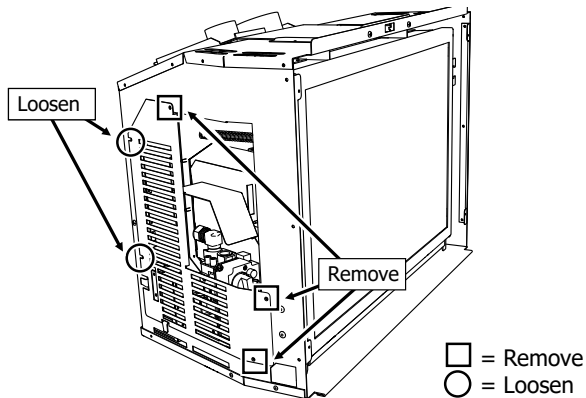

2. Remove 5 screws and loosen 2 screws along the bottom to remove fan access panel.

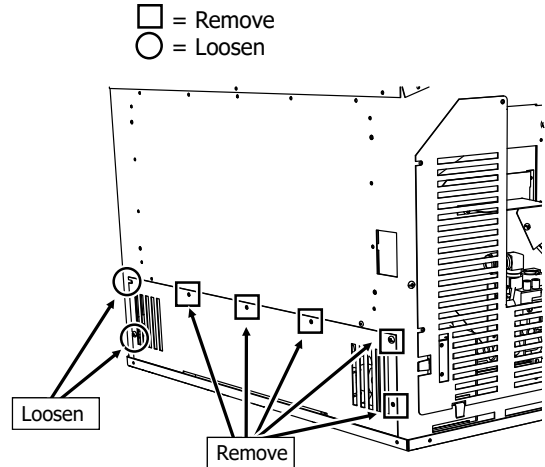

3. Remove ground wire of main harness (X1) from the ground stud.

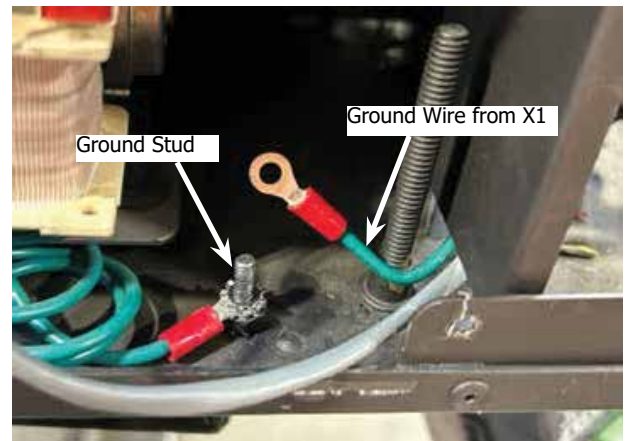

# installation

4. Remove the IFC (2 screws).



5. Remove main wire harness (X1) from the ICF and replace with one provided in the kit.

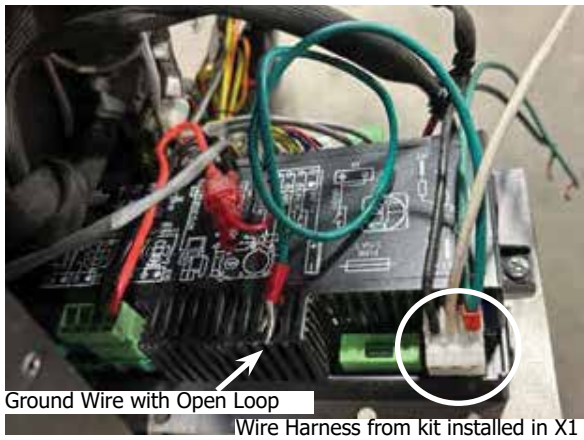

6. Re-install ground wire with open loop back onto ground stud.
7. Remove the plug and harness from the unit and discard.
8. Re-install the IFC (two screws) with the 3 wires of the main harness (X1) routed out.
9. Remove the knockout from the unit for armored cable installation.

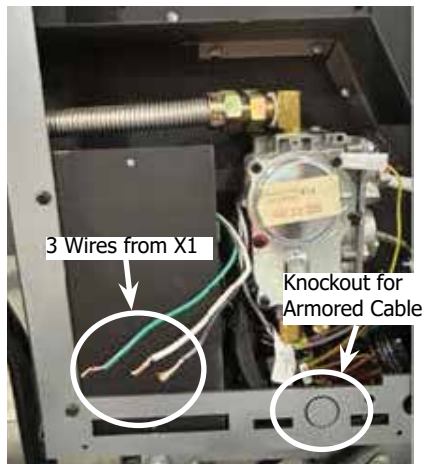

10. Install the armored cable then connect the neutral (white), live (black) and ground wires (green & bare copper) to the main harness (X1).

11. Tuck wires under the valve then re-install the control panel cover.



# installation

12. The gas insert should be placed on the fireplace hearth in position to access the left/right side of the insert depending on model.
13. Route the conduit on the wiring harness through the fireplace to a junction box outside of the fireplace.  
NOTE: Leave extra slack in the conduit to allow for servicing of the gas insert. When placing the gas insert into place, route the conduit away from the insert to prevent it from contacting or being pinched by the insert.
14. Install gas liner and optional accessories to complete the installation.

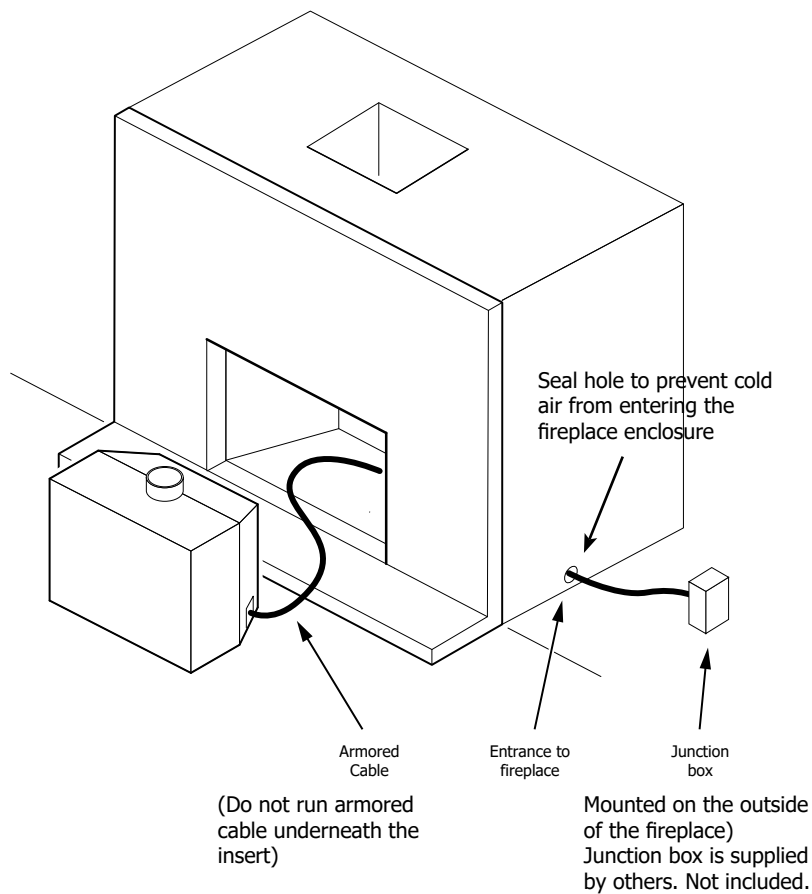

NOTE: Shown with armored cable on the right side. Depending on model: may be on left side.

**MINIMUM CLEARANCES TO COMBUSTIBLES**

The clearances listed below are minimum distances unless otherwise stated:

A major cause of fires is failure to maintain required clearances (air space) to combustible materials. It is of the greatest importance that this decorative gas appliance be installed only in accordance with these instructions.

Clearance:	Dimension	Measured From:
<b>A: Sides</b>	6" / 152 mm	***From inside edge of faceplate / doors
<b>B: Ceiling</b>	60" / 1524 mm	From Base of Unit
<b>C: Mantel (Min. Height)</b>	*28" / 711mm 38" / 965mm	From Base of Unit From Base of Unit
<b>D:Min. Hearth Depth</b>	12" / 305mm	Not required if unit raised 3-1/2" off floor
<b>E: Min. Hearth Length</b>	36" / 914mm	
<b>G: Max. Mantel Depth</b>	0 -12" / 305 mm	@ 47" (1193mm) from bottom of unit without deflector @12" (305mm) deep @ 37" (940mm) from bottom of unit with 3-1/2" deflector @12" (305mm) deep
<b>K: Min. Alcove Width</b>	54" / 1372 mm	
<b>L: Max. Alcove Depth</b>	36" / 914 mm	
<b>M: Mantel Deflector</b>	3-1/2" / 89mm	

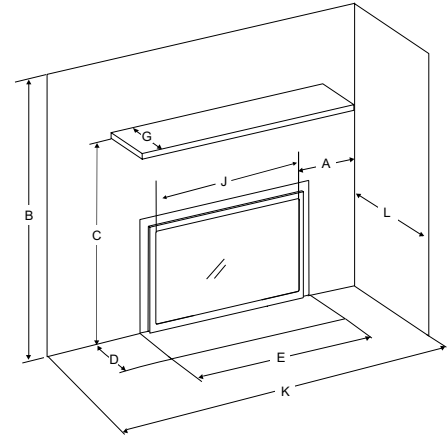

Diagram 1

**NOTE:** 36" (914 mm) wide x 12" (305mm) deep non combustible hearth is required in front of the appliance, unless the unit is raised 3-1/2" (89 mm) off the floor surface.  
\*An optional 3-1/2" deflector, reduces the mantel height to 28" from bottom of unit @ 1" depth.  
**(J):** \*\*\*Measured from inside edge of faceplate/doors - Reference Only: 27-1/4" / 692mm

**MANTEL CLEARANCES WITHOUT DEFLECTOR**

**MANTEL CLEARANCES WITH 3-1/2" DEFLECTOR**

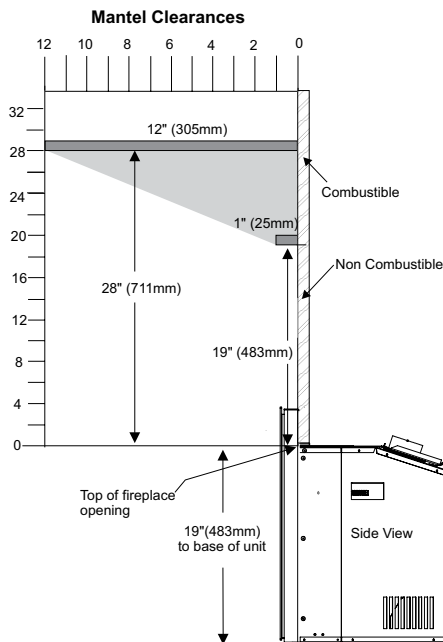

Diagram 2

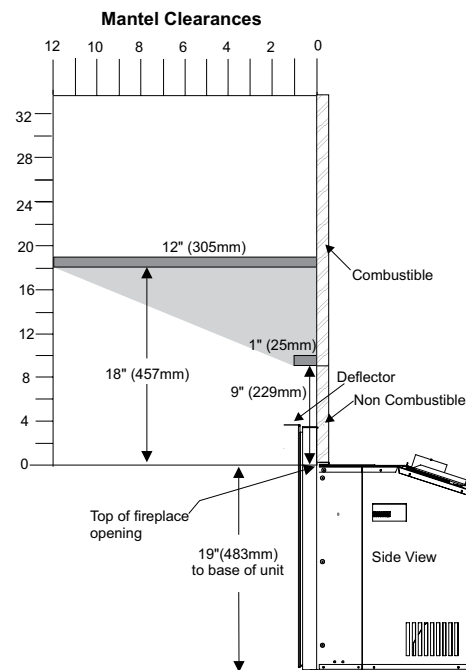

Diagram 3

**WARNING**  
Although this appliance passes safety certification, the hearth in front of the fireplace becomes very hot when the fireplace heats. Do not use the hearth as a seat or shelf.

**Note:** A 3-1/2" mantel deflector to reduce mantel height to 28" from bottom of unit @ 1" depth.  
A noncombustible mantel may be installed at a lower height if the framing is made of metal studs covered with a non-combustible board. The non-combustible

mantel when installed at a lower overall height may not be lower than 6 inches from the top of the fireplace opening.

**Note:** All material used must be **completely non-combustible**.

# installation

## GAS CONNECTION

**GAS CONNECTION WARNING:**  
**Only persons licensed to work with gas piping may make the necessary gas connections to this appliance.**

1. If the appliance is to be installed into an existing chimney system, thoroughly clean the masonry or factory built fireplace.
2. The appliance is provided with an opening on the left hand side of the control compartment. A 3/8" NPT gas supply pipe must be brought near this inlet hole.
3. Locate the center point where the vent will pass through the chimney above the appliance. Move the appliance into the exact location where it is to be installed. Ensure that the Insert is level.
4. Do not cut any sheet-metal parts of the fireplace, in which the gas fireplace insert is to be installed.
5. If the factory-built fireplace has no gas access hole(s) provided, an access hole of 1-1/2" (37.5mm) or less may be drilled through the lower sides or bottom of the firebox in a proper workmanship like manner. This access hole must be plugged with a non-combustible insulation after the gas supply line has been installed.

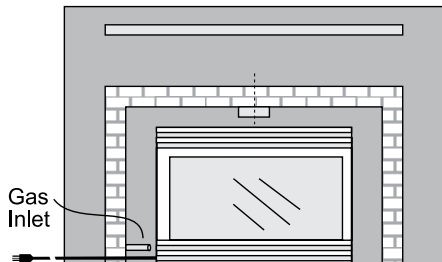

Gas & Electrical Connections

## THE APPLIANCE MUST NOT BE CONNECTED TO A CHIMNEY FLUE SERVING A SEPARATE SOLID FUEL BURNING APPLIANCE.

Masonry chimneys may take various contours which the flexible liner will accommodate. However, **keep the flexible liner as straight as possible**, avoid unnecessary bending.

The LRI3E-11/HRI3E-11 are also approved for use with a 2" liner for air intake and a 3" liner for exhaust. This would be suitable for a Class A wood burning chimney with a minimum 6" round flue.

The chimney must be lined with one 2" diameter liner for intake and one 3" diameter liner for exhaust. The minimum vent length is 8' and maximum is 35'.

The Air Intake pipe must be attached to the inlet air collar of the termination cap. Periodically check that the vent is unrestricted.

## INSTALLATION WITH 3" & 2" LINERS

**IMPORTANT :** Use only the listed termination caps/flex liner noted below and on next page. This appliance was tested/certified as a complete system with the noted termination caps and flex liner. Use of other termination caps/flex liner not listed in this manual will void the warranty and certification of this appliance. It is also important not to enclose the termination cap inside a masonry chimney rain cap, or similar. The termination must be exposed on all four sides and above to exhaust and to draw air into the firebox.

Part #	Description
948-305	3" Flex - 35 ft. (exhaust)
948-316	2" Flex - 35 ft. (intake)
946-582	Regency Co-linear DV Vertical Termination Cap, Flashing & 2" Collar

Vent Run	Vent Restrictor Position
Up to 8'	Position 1
Beyond 8'	No restrictor

**NOTE:** See instructions in the "Vent Restrictor Position" section on positioning of the vent restrictor.

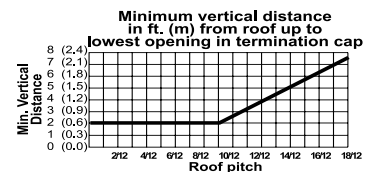
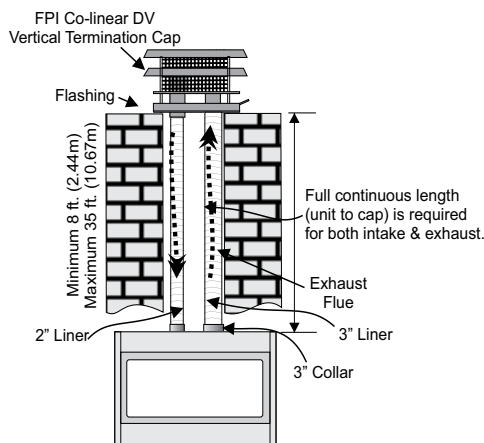



## ALTERNATE APPROVED CAPS/ADAPTOR

46DVA-GK 3" Co-linear Adaptor with flashing  
 46DVA-VC Vertical Termination Cap  
 or  
 46DVA-VCH High Wind Cap  
 \* 948-417/P 2" to 3" Increaser (Air inlet)

\*Note : The 46DVA-GK Co-linear Adaptor with flashing comes with 2 - 3" collars. The increaser is required to adapt the flex (air inlet side) which is 2 inch to the 46DVA-GK Co-linear Adaptor with flashing. The optional 2"-3" increaser for the air inlet must be affixed to the termination end between the 2" liner and the 46DVA-GK Co-linear Adaptor with flashing. This must not be affixed to the appliance stove collar. In areas of consistently high winds, we recommend using the Simpson Dura-Vent System (46DVA-GK adapter and 46DVA-VCH high-wind cap). The Air Intake pipe must be attached to the inlet air collar of the termination cap. This chimney system is also ideal when the chimney termination is found in applications where this appliance is being installed into a factory built fireplace.

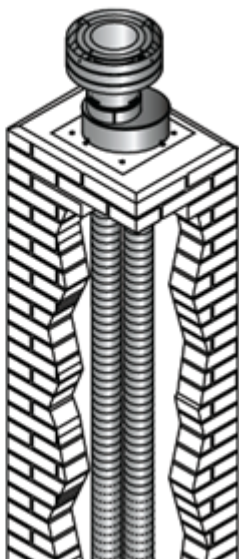

## STANDING PILOT

The LRI3E-11/HRI3E-11 use a heat exchanger and efficient combustion technology to provide extreme heating efficiencies. The more efficient an appliance becomes, the lower the flue gas temperatures becomes. On start-up, flue temperatures are required to initiate venting action.

Here are some considerations when setting up the LRI3E-11/HRI3E-11:

When operating the unit in temperatures below 50°F/10°C, run the pilot in "Standing Pilot" mode, 1. Press and hold the small flame icon on the hand held remote control to set the appliance at continuous pilot.

Note: If after 7 days the appliance has not had a call for heat, the pilot will extinguish and will not be present. To enable pilot operation you will need to repeat steps for continuous pilot operation.

## VENT RESTRICTOR PLATE INSTALLATION

Note: only installed on runs at the minimum 8 feet vent height from above unit. If longer than 8 feet the restrictor is not required.

1. Remove flue connector plate by sliding out toward the back of the unit - see next page.
2. Remove left flue connector plate guide by removing 2 screws as shown below.

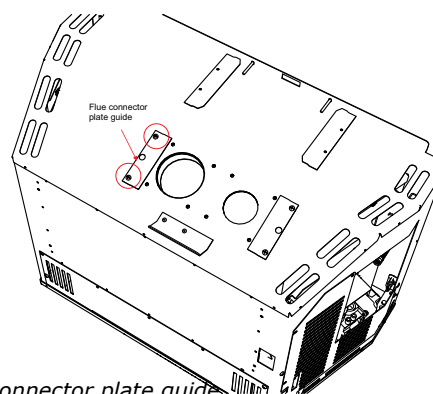

*Remove connector plate guide*

3. Flip the flue connector plate gasket to the right (out of the way) to allow ease of installation of the vent restrictor.
4. Install vent restrictor with 2 screws in location shown below.

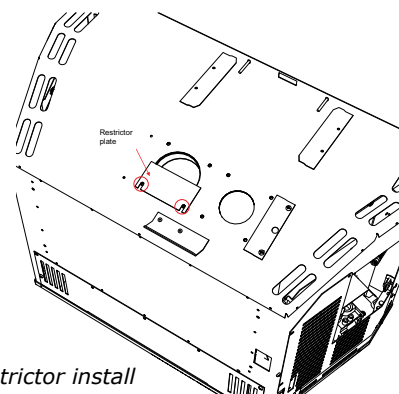

*Vent restrictor install*

# installation

## FLUE / VENT INSTALLATION



**NOTE:** Flue Plate Connector Gasket must not be damaged or removed. Care must be taken to ensure that this gasket remains intact to prevent flue leakage.

### Connecting the Vent Liners

1. Detach the Flue Connector Plate from the unit by removing the Connector Plate Screws and sliding the Flue Connector Plate forward and off the unit.

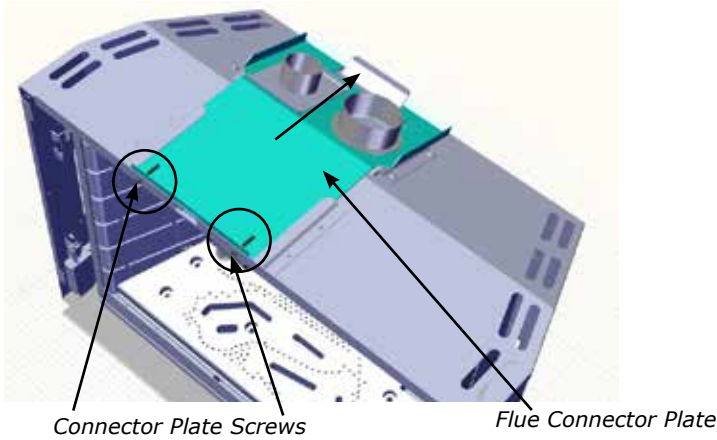

2. Attach the Flue Liners onto the Flue Connector Plate using non RTV type sealant, then fasten with 3 screws. See the section in this manual on Venting installation.
3. Position the unit in front of the fireplace opening, start the Flue Connector Plate into the Flue Connector Plate Guides.

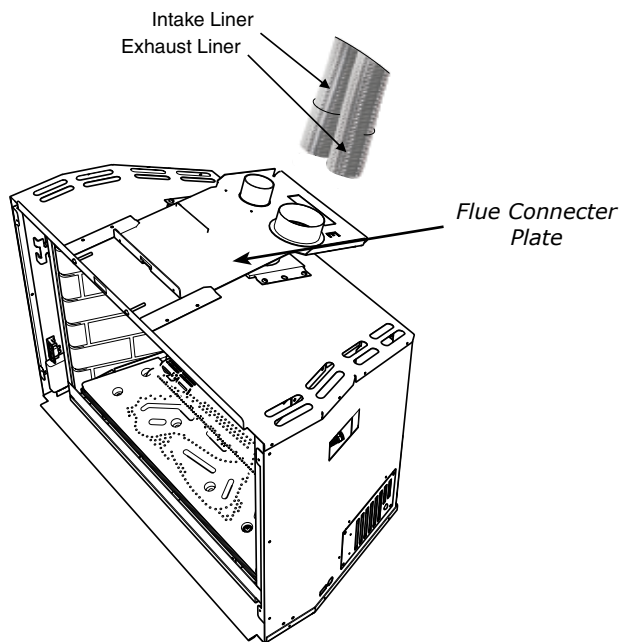

### WARNING:

Failure to position the parts in accordance with these diagrams or failure to use only parts specifically approved with this appliance may result in property damage or personal injury.

4. Use the Flue Connector Slide Tool to slowly pull the Flue Connector Plate forward as you move the Insert rearward into the Fireplace Chase.

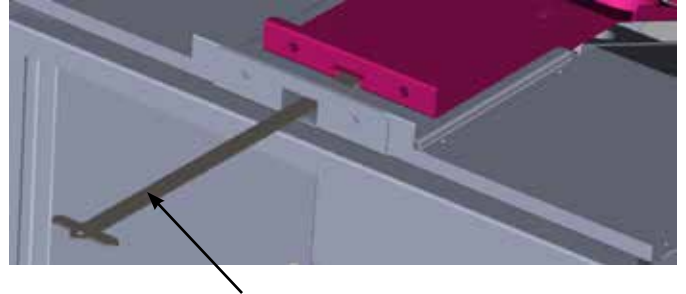

Flue Connector Slide Tool

5. When the Flue Connector Plate is close to the front of the unit, engage the Flue Connector Screws and carefully tighten the Flue Connector Plate the final amount.

\*\* Make sure the Rear Tab connects into the slot in the Flue Connector Plate. Failure to do so will result in flue gas leakage and degrade the operation of the unit \*\* (See diagram below of location.)

The Flue connection is complete when the Flue Connector Plate is fully forward and the Rear Tabs are fully engaged.

6. Remove the Flue Connector Tool and store for future use.



Tab connected correctly

## AIR SHUTTER ADJUSTMENT

The burner aeration is factory set but may need adjusting due to either the local gas supply or altitude.

Air Shutters are required to increase or decrease the amount of air that is mixed with the fuel before combustion. This will have an affect on how well the fuel combusts and how the flame appears physically.

Low primary air will leave a taller, yellower flame while higher primary air will leave a lower, bluer flame.

This setting is largely for appearance, however, not enough primary air may lead to carboning, sooting or a flame that reaches the top of the firebox. Situations that may require more primary air are; units that are burning propane, units installed at higher elevations or units that are run on high most of the time.

Unit	Fuel Type	Min. Air Setting
LRI3E	NG	1/8" (3mm)
LRI3E	LP	1/4" (6mm)
HRI3E	NG	1/8" (3mm)
HRI3E	LP	5/16" (8mm)

NOTE: In higher elevations, air shutter settings may have to be opened more to compensate.

The minimum air settings noted for the HRI3 are good for both media and driftwood log set.

**CAUTION:** Carbon will be produced if air shutter is closed too much.

**Note:** any damage due to carboning resulting from improperly setting the aeration controls is NOT covered under warranty.

**Note:** Aeration Adjustment should only be performed by an authorized Regency Installer at the time of installation or service.

LRI3E- Remove the burner by removing 2 screws in locations shown below. Slide burner to the left and lift out to remove.



LRI3E

HRI3E - Remove the burner by removing 5 screws in locations shown below to remove burner cover and 2 screws to remove burner (shown below). Slide burner to the left to remove.

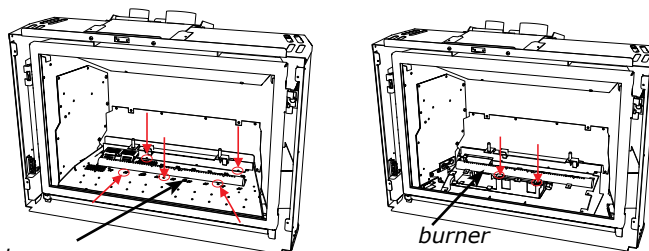

burner cover

burner

HRI3E

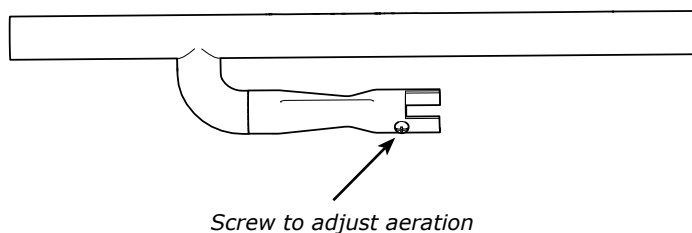

Screw to adjust aeration

# installation

## WIRING DIAGRAM - SYSTEM WITH FAN (LRI3E-11 / HRI3E-11)

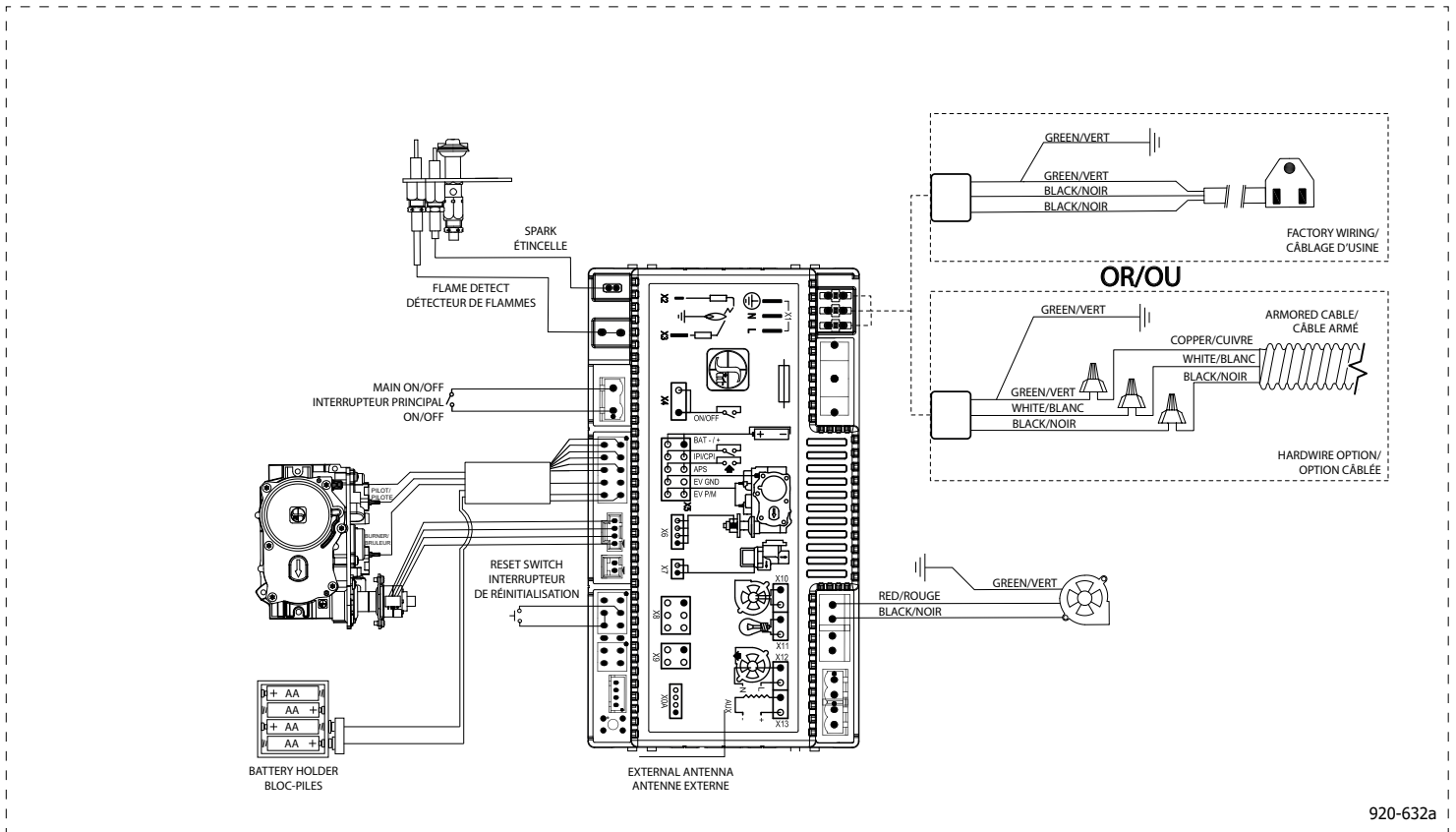

**CAUTION: Label all wires prior to disconnection when servicing controls. Wiring errors can cause improper and dangerous operation.**

**Caution: Ensure that the wires do not touch any hot surfaces and are away from sharp edges.**

If any of the original wire as supplied with the appliance must be replaced, it must be replaced with type CPE wire or its equivalent.

**IMPORTANT:** The 120V fan control module serves as the power source for this unit. The AA batteries in the battery holder are recommended as a backup in case 120 volt power is lost within the home.

HRI3E-NG11 SYSTEM DATA	
Min. Supply Pressure	5" WC (1.25 kpa)
Max. Supply Pressure	1/2" Psi (3.45 kpa)
Manifold Pressure - High	3.5" WC (0.87 kpa)
Manifold Pressure - Low	1.6" WC (0.40 kPa)
Orifice Size	#45 DMS
Maximum Input	19,500 Btu/h (5.71 kW)
Minimum Input	14,000 Btu/h (4.10 kW)

HRI3E-LP11 SYSTEM DATA	
Min. Supply Pressure	11" WC (2.73 kpa)
Max. Supply Pressure	1/2" Psi (3.45 kpa)
Manifold Pressure-High	10" WC (2.49 kpa)
Manifold Pressure-Low	6.4" WC (1.60 kpa)
Orifice Size	#55 DMS
Maximum Input	19,500 Btu/h (5.71 kW)
Minimum Input	14,000 Btu/h (4.10 kW)

LRI3E-NG11 SYSTEM DATA	
Min. Supply Pressure	5" WC (1.25 kpa)
Max. Supply Pressure	1/2" Psi (3.45 kpa)
Manifold Pressure - High	3.5" WC (0.87 kpa)
Manifold Pressure - Low	1.6" WC (0.40 kPa)
Orifice Size	#45 DMS
Maximum Input	20,500 Btu/h (6.0 kW)
Minimum Input	14,000 Btu/h (4.10 kW)

LRI3E-LP11 SYSTEM DATA	
Min. Supply Pressure	11" WC (2.73 kpa)
Max. Supply Pressure	1/2" Psi (3.45 kpa)
Manifold Pressure-High	10" WC (2.49 kpa)
Manifold Pressure-Low	6.4" WC (1.60 kpa)
Orifice Size	#55 DMS
Maximum Input	19,000 Btu/h (5.57 kW)
Minimum Input	15,500 Btu/h (4.54 kW)

## HIGH ELEVATION

This unit is approved for altitude 0 to 4500 ft. (CSA 2.17-2017).

## GAS LINE INSTALLATION

Since some municipalities have additional local codes it is always best to consult with your local authorities and the CSA B149.1 installation code.

For USA installations follow local codes and/or the current National Fuel Gas Code, ANSI Z223.1.

When using copper or flex connectors use only approved fittings. Always provide a union so that gas lines can be easily disconnected for servicing. Flare nuts for copper lines and flex connectors are usually considered to meet this requirement.

**NOTE: A shutoff / dante valve should be supplied in or near the unit (or as per local codes) for ease of servicing this appliance.**

**IMPORTANT: Always check for gas leaks with a soap and water solution or gas leak detector. Do not use open flame for leak testing.**

## PILOT ADJUSTMENT

Periodically check the pilot flames. Correct flame pattern has two strong blue flames: 1 flowing around the flame sensor and 1 flowing across the burner (it does not have to be touching the burner).

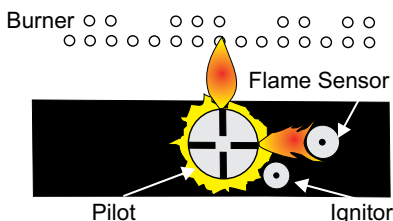

**Note: If you have an incorrect flame pattern, contact your Regency® dealer for further instructions.**

Incorrect flame pattern will have small, probably yellow flames, not coming into proper contact with the rear burner or flame sensor.

## GAS PIPE PRESSURE TESTING

The appliance must be isolated from the gas supply piping system by closing its individual manual shut-off valve during any pressure testing of the gas supply piping system at test pressures equal to or less than 1/2 psig. (3.45 kPa). Disconnect piping from valve at pressures over 1/2 psig.

The manifold pressure is controlled by a regulator built into the gas control, and should be checked at the pressure test point.

**Note: To properly check gas pressure, both inlet and manifold pressures should be checked using the valve pressure ports on the valve.**

1. Make sure the unit is in the "OFF" position.
2. Loosen the "IN" and/or "OUT" pressure tap(s), turning counterclockwise with a 1/8" wide flat screwdriver.
3. Attach manometer to "IN" and/or "OUT" pressure tap(s) using a 5/16" ID hose.
4. Turn the unit on with the remote or wall switch
5. The pressure check should be carried out with the unit burning and the setting should be within the limits specified on the safety label.
6. When finished reading manometer, turn off the unit, disconnect the hose and tighten the screw (clockwise) with a 1/8" flat screwdriver.  
**Note: Screw should be snug, but do not over tighten.**

## 885 S.I.T. VALVE DESCRIPTION

- 1) 6 Stage flame adjustment
- 2) Pilot adjustment
- 3) Inlet Pressure Tap
- 4) Outlet Pressure Tap
- 5) Pilot Outlet
- 6) Main Gas Outlet
- 7) Main Gas Inlet

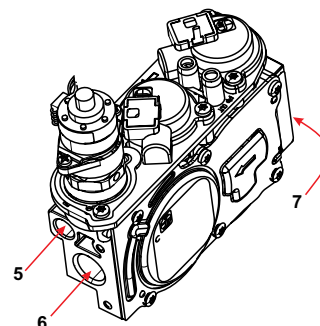
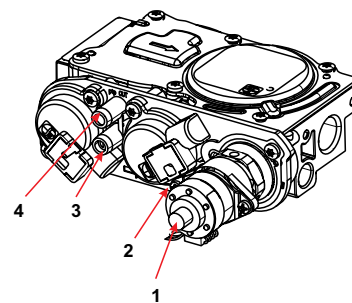

# installation

## CONVERSION FROM NG TO LP LRI3E/HRI3E USING PROFLAME 885 VALVE

**THIS CONVERSION MUST BE DONE BY A QUALIFIED GAS FITTER  
IF IN DOUBT DO NOT DO THIS CONVERSION!**

### WARNING

This conversion kit shall be installed by a qualified service agency in accordance with the manufacturer's instructions and all applicable codes and requirements of the authority having jurisdiction. If these instructions are not followed exactly, a fire, explosion or production of carbon monoxide may result causing property damage, personal injury or loss of life. The qualified service agency is responsible for the proper installation of this kit. The installation is not proper and complete until the operation of the converted appliance is checked as specified in the manufacturer's instructions supplied with the kit.

Conversion Kit #717-977 includes:

1	904-575	Burner Orifice #55
1	910-037	Pilot Orifice #30
1	908-590	Decal - Conversion to LP
1	911-011	Stepper Motor - LP
1	904-529	5/32" long Allen Key
1	908-528	Label Propane Red
1	920-032	Instruction Sheet

**This conversion should be done before the unit is initially installed:**

**If installed already, the draft hood assembly will need to be removed so appliance may be slid out from the fireplace opening for ease of conversion. See manual for details**

**Before you begin:**

**Shut off the gas supply to the unit.**

**Disconnect all electrical supply to the unit.**

**Always let the appliance cool to room temperature before servicing.**

1. Remove faceplate, glass door, inner panels, glass crystals, media, logs (if already installed)—see instructions in the manual.
2. Slide unit out and remove 3 front screws and loosen 2 back screws to remove the left side control cover.

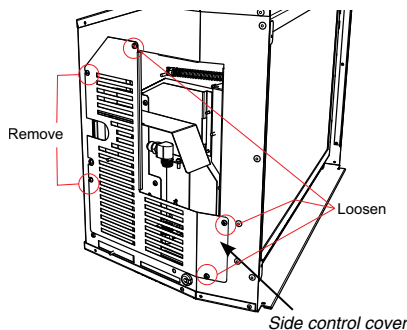

3. Disconnect the cable coming from the pressure regulator motor.

4. Remove and discard 2 Pressure regulator screws A (T20 or slot), Pressure Regulator B, Spring and Diaphragm C.
5. Ensure the rubber gasket, which is prefitted as part of the Assembly, is properly positioned. Install the new Pressure Regulator using the 2x M4 x .7 screws supplied. Tighten the screws to 25lb-in. In the event that the screw threads are cross threaded or stripped, replace the valve assembly.

Install the enclosed propane identification label to the valve body where it can be easily seen.

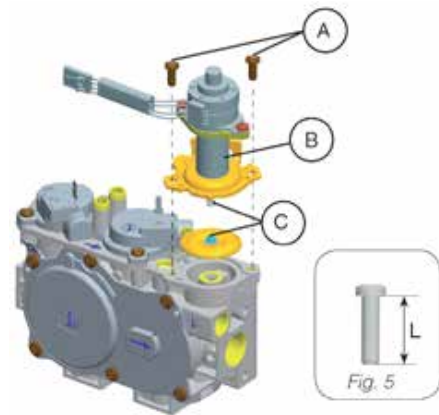

6. Reattach the pressure regulator wire.
7. LRI3E- Remove the burner by removing 2 screws in locations shown below.



LRI3E

HRI3E- See next page.

HRI3E - Remove the burner by removing 5 screws in locations shown below to remove burner cover and 2 screws to remove burner (shown below).

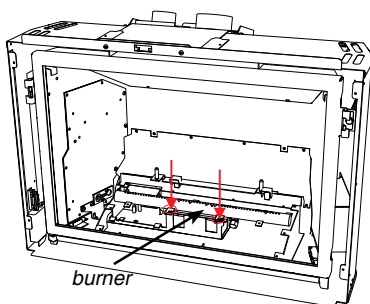
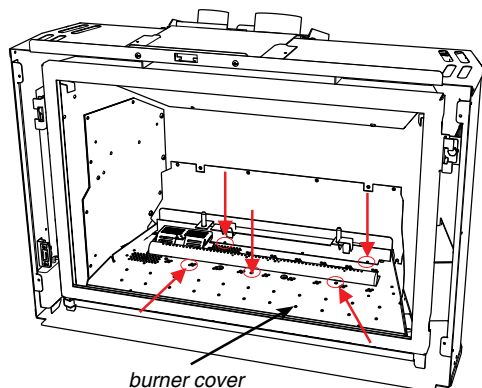

HRI3E

8. From inside the firebox, remove pilot retainer clip with pliers and pull off the pilot cap to expose the pilot orifice.

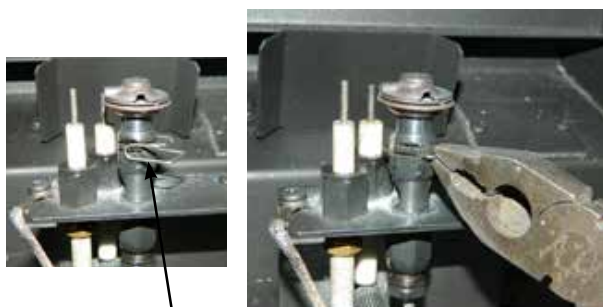

Pilot retainer clip



9. Unscrew the pilot orifice with the Allen key; then replace with the LPG pilot orifice and the pilot cap, provided in the kit.



10. Remove burner orifice with a 1/2" wrench. Use another wrench to hold onto the elbow behind the orifice. Recycle orifice.



11. Reinstall new burner orifice LPG stamped #55 and tighten.

12. Attach the label "This unit has been converted to LPG" near or on top of the serial # decal.

13. Replace red "NG" label with yellow "LPG" label.

14. Adjust aerations settings:

LRI3E = 1/4" (6 mm)

HRI3E = 5/16" (8 mm))

**NOTE:** In higher elevations, air shutter settings may have to be opened more to compensate.

The minimum air settings noted for the HRI3E are good for both media and driftwood log set.

15. Reinstall burner removed in Step 7.

16. Check for gas leaks.

17. Check inlet and outlet pressures. See Gas Pipe Pressure Testing in manual.

18. Reverse steps 2-1 to reassemble unit.

19. Check operation of flame control.

**Installer Notice:**  
These instructions must be left with the appliance.

# installation

## MEDIA INSTALLATION

Spread the Media evenly over the burner. Ensure installed media does not overlap excessively as this will affect the flame pattern.

### IMPORTANT NOTE:

Only the supplied approved Media is to be used with these fireplaces. Use of any other type of media can alter the unit's performance, any damage caused by the use of any unapproved media will not be covered under warranty.

When using Ceramic Spa/Volcanic Stones **DO NOT** cover burner ports or pilot light that leads to pilot flame.

BURNER PACKAGES			
Unit	Glass Crystals	Fire Beads	Stones - Spa / Ceramic / Volcanic Stones / Pebbles / Driftwood Logs
HRI3E	4 lbs	4 lbs	4 lbs Glass (burner) + 1 package (70 Spa Stones) 4 lbs Beads (burner) + 1 package (70 Spa Stones) 4 lbs Glass (burner) + 26 Volcanic Stones 4 lbs Beads (burner) + 26 Volcanic Stones 4 lbs Glass (burner) + 1 bags Pebbles
<b>NOTE:</b> Media is not supplied with the unit. Must purchase separately - see quantities above. Spa stone package contains 70 stones.			



*DO NOT block pilot area with glass crystals or other media  
Note: Crystals and rocks may be placed on top of the pilot*



*Installing Glass Crystals*



**Caution:** Do not cover pilot or burner ports with stones.



**HRI3E OPTIONAL LOG SET INSTALLATION**

Read the instructions below carefully and refer to the images. If the logs are broken do not use the unit until they are replaced. Broken logs can interfere with pilot operation.

Improper positioning of the logs may create carbon build-up and can alter the unit's performance which is not covered under warranty.

\*For Touch Ups: Dark Brown paint is included.

1	Rear Centre Log
2	Left Angled Log
3	Right Angled Y-Shaped Log
4 a	Left Front Log Piece
4b	Right Front Log Piece
	Embers

Ensure unit has cooled to room temperature and remove glass door.

1. Install 4lbs of glass crystals on the burner—see glass crystal install in the installation manual for details.
2. Install the two log support brackets—install each bracket measuring 4-1/2" from the side panel to the outside of the bracket.



Log bracket install

3. Install Log 1 at the back of the firebox—resting on the firebox and the brackets installed in the previous step.



Log 1 install

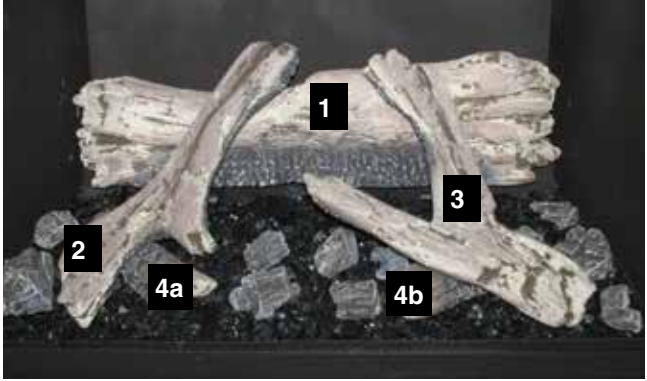

4. Install Log 4a—seat it on the glass crystals, burned end facing to the back corner of the firebox. Install Log 2 diagonally, it will rest in the indent of Log 1 and the small Y in Log 2 will rest on Log 4a as shown.



Log 2 and 4a install

5. Install Log 3, rest the back part of the "Y" in the indent of Log 1, the opposite end will rest on the glass crystals.
6. Tilt Log 3 up slight and place Log 4b halfway underneath Log 3, at the "Y" junction.

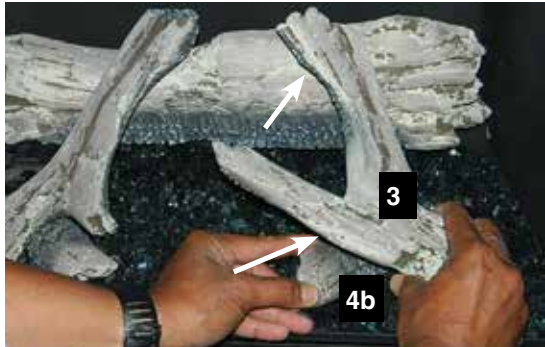

Log 3 and 4b install

# installation

7. Place the supplied embers on the glass crystals as shown.

Note: do not cover burner ports with embers. This will cause sooting on the logs.



*Ember install*

8. Test fire to ensure proper light off (make sure flame flows smoothly from one end of the burner to the other). If there is any flame hesitation, check that area for any blockage of the burner ports.



*Final install*

## LRI3E LOG SET INSTALLATION

Read the instructions below carefully and refer to the images. If the logs are broken do not use the unit until they are replaced. Broken logs can interfere with pilot operation.

Improper positioning of the logs may create carbon build-up and can alter the unit's performance which is not covered under warranty.

\*For Touch Ups: Dark Brown paint is included.

1	Rear Centre Log
2	Left Angled Log
3	Right Angled Log
4	Left Front Log Piece
5	Right Front Log Piece
6	Centre Log
7	Centre Right Cross Log

Ensure unit has cooled to room temperature and remove glass door.

1. Install Log 1 at the back of the burner. Line up pin locators on Log with pins on the burner and seat Log

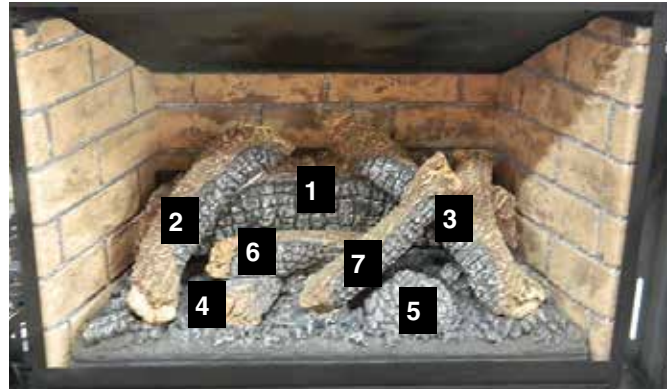

Log 1 install

2. Install Log 2—Log 2 will rest diagonally in the indent on the left side of Log 1 the bottom end with rest in the indent of the burner as shown below.



Log 2 install

3. Install Log 3—Log 3 will rest diagonally in the indent on the right side of Log 1, the bottom end with rest in the indent of the burner as shown below.



Log 3 install

4. Install Log 4 on the left side in the indent of the burner as shown below.

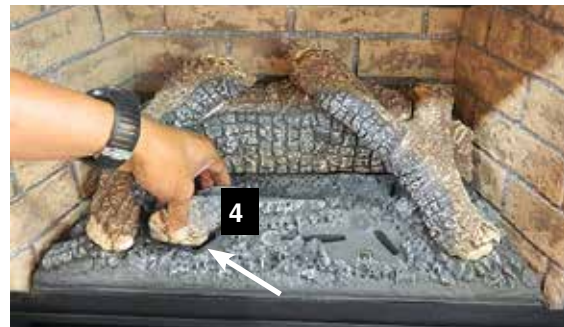

5. Install Log 5 on the right side in the indent of the burner as shown below.



# installation

6. Install Log 6 in the indent of the burner as shown below.



*Log 6 install*

7. Install Log 7 on a diagonal, one end will rest in an indent in the burner and the other end will rest at the "Y" on Log 3.



*Log 7 install*

8. Test fire to ensure proper light off (make sure flame flows smoothly from one end of the burner to the other). If there is any flame hesitation, check that area for any blockage of the burner ports.



*Final install*

**BRICK PANEL INSTALLATION**

**Important: This appliance cannot be operated without brick (LRI3E-11 only), enamel panels (HRI3E-11/LRI3E-11) or painted panels (HRI3E-11 only) installed.**

Brick panels are soft and fragile. Use caution when handling the panels, being careful not to jar them or scratch the painted surfaces.

- 1. Carefully unpack brick panels.
- 2. Install back brick panel - place against back wall of firebox, the side panels (once installed) will secure the back panel in position.

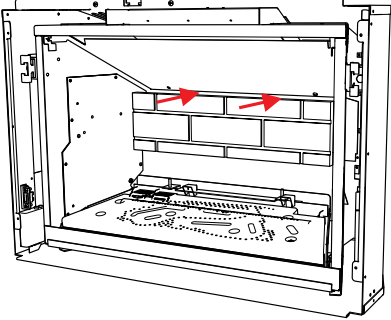

*Install back brick panel*

- 4. Loosen bracket screw in firebox in location shown below, slide right brick panel into position until it contacts the back panel. Slide the panel bracket on from the back of the unit and tighten the bracket screw.

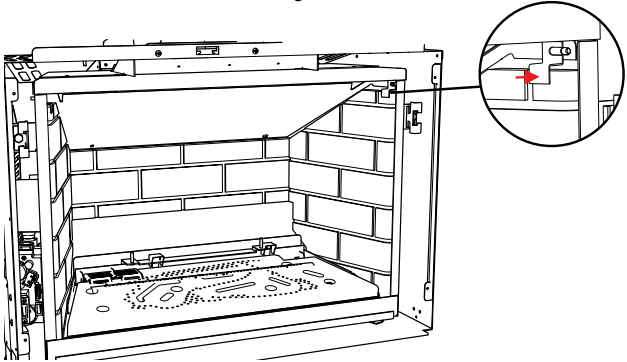

*Install right brick panel*

- 3. Loosen bracket screw in firebox in location shown below, slide left brick panel into position until it contacts the back panel. Slide the panel bracket on from the front of the unit and tighten the bracket screw.

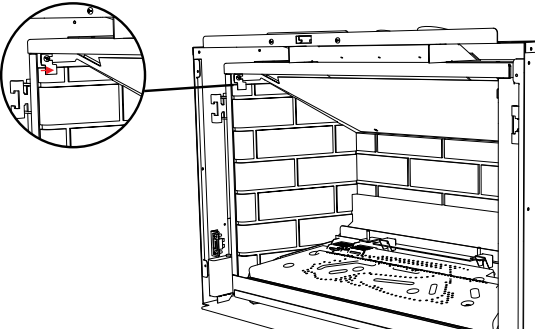

*Install left brick panel*

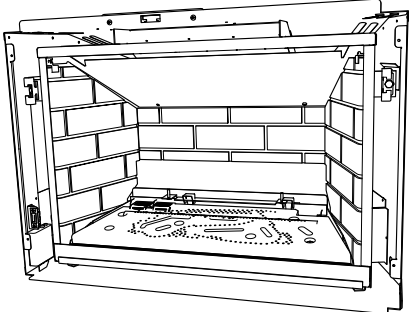

*Final install*

# installation

## PAINTED BLACK AND ENAMEL PANEL INSTALLATION

**Important: This appliance cannot be operated without brick (LRI3E-11), enamel panels (HRI3E-11/LRI3E-11) installed or painted panels (HRI3E-11 only) installed.**

### Before you Start:

#### Black Enamel Panels Only

- Black Enamel panels must be inspected for scratches and dimples prior to installation. All claims to be recorded at this time. Claims for damage after installation will not receive consideration.

- Black Enamel panels will discolor a little during normal operation. This is normal and should not be considered a defect.

- \* All hand and finger marks **MUST** be cleaned off with a soft cloth. Use an ammonia based cleaner (ie. glass cleaner) to remove any fingerprints before applying heat to the unit. **Failure to do this will result in burn stains on panels which you will be unable to remove.** Not protected by product warranty.

1. Carefully unpack painted black or enamel panels.
2. Install back painted/enamel panel - place against back wall of firebox, the side panels (once installed) will secure the back panel in position.

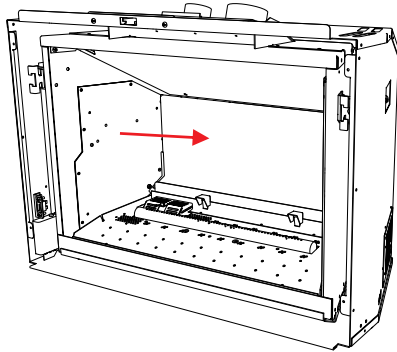

3. Loosen bracket screw in firebox in location shown below, slide left panel into position until it contacts the back panel. Slide the panel bracket on from the front of the unit and tighten the bracket screw.

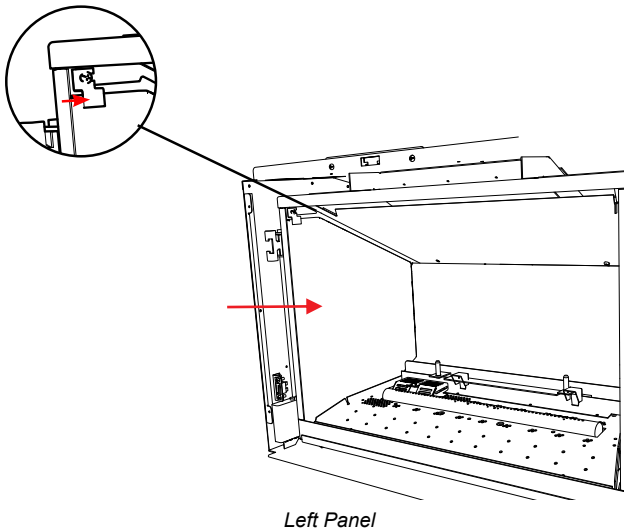

4. Loosen bracket screw in firebox in location shown below, slide right panel into position until it contacts the back panel. Slide the panel bracket on from the back of the unit and tighten the bracket screw.

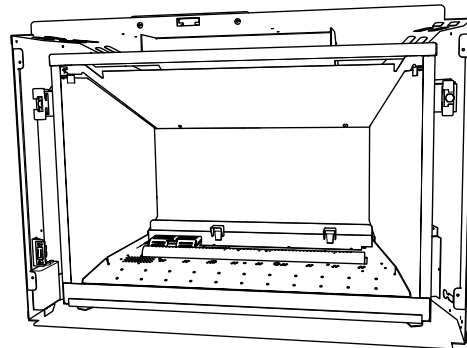
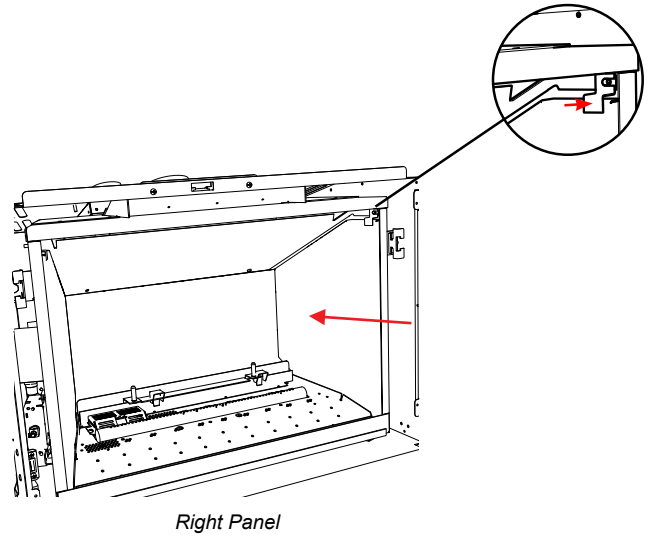

**GLASS DOOR REMOVAL / INSTALLATION**

**WARNING: Do not operate the appliance with the glass panels removed, cracked or broken. Replacement of the glass panels should be done by a licensed or qualified service person.**

1. Insert the door tool into the side door latch.

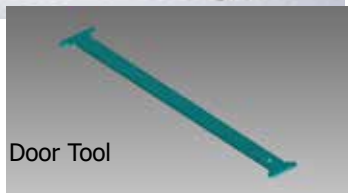
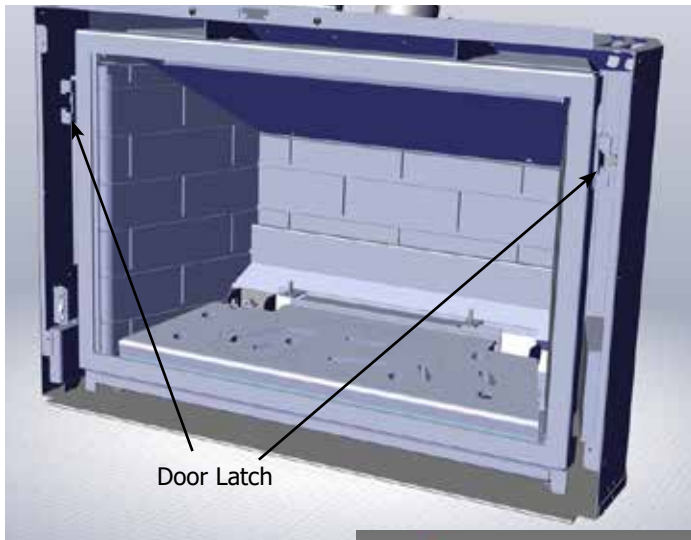

2. Pull forward until the side door latch is disengaged from the door frame.

3. Push to the outside of the unit until the side door latch is below the door frame.



4. Release the side door latch until it reaches its resting point.

5. Support the top of door as it will fall forward after the 2nd door latch is released. The bottom of the door will be supported in the lower frame.

**Note:** Gently ease the glass back. Do not put any force on the glass assembly as this may cause damage to the lower frame and or glass frame assembly.

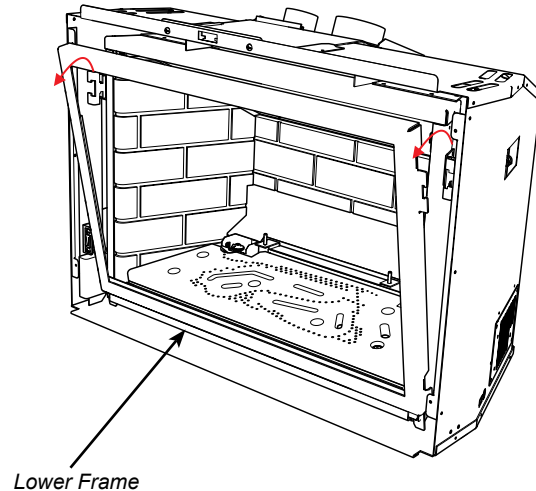

6. Remove the door tool and repeat steps 1-4 on the opposite door latch.

7. To install the glass door - reverse steps.

# installation

## VIGNETTE FACEPLATE WITH SAFETY SCREEN INSTALLATION

1. Install the back faceplate and secure with 4 screws as shown.

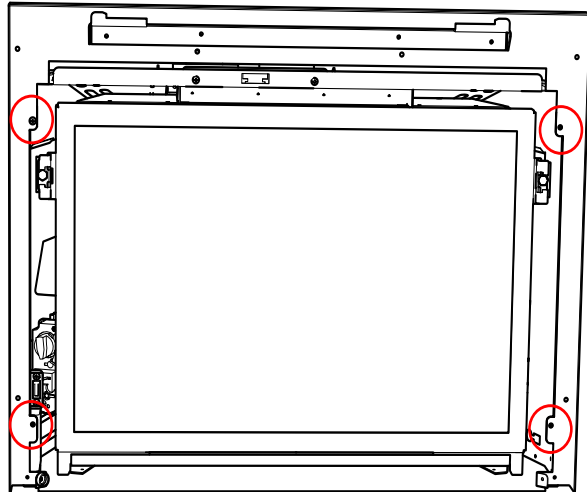

*Back Faceplate Install*

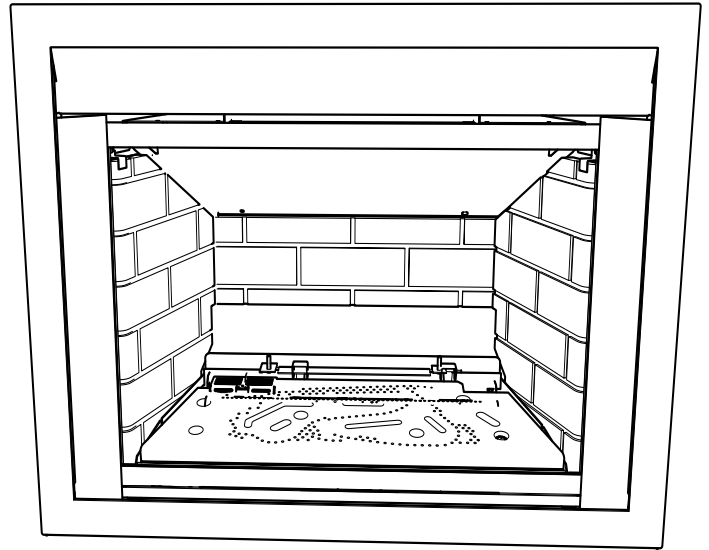

*Final Install*

2. Install the outer (front) faceplate by hooking the flange over the hanger located on the back faceplate (installed in the previous step) as shown.

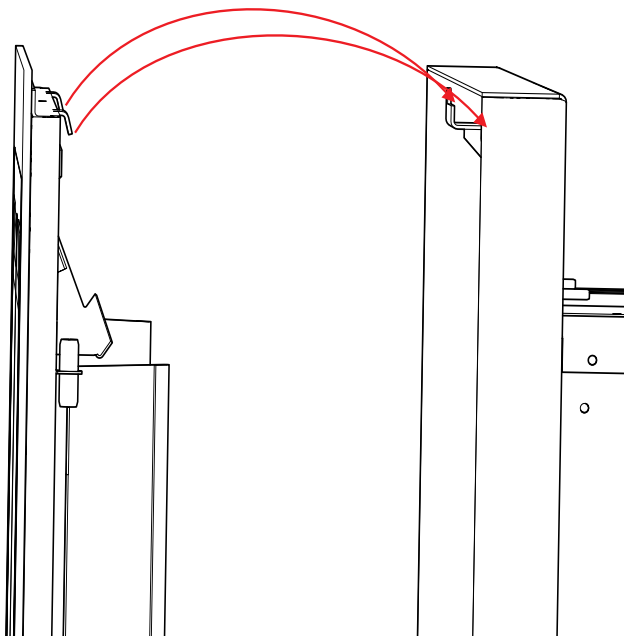

*Front Faceplate Install*



**INLAY INSTALLATION**

- 1. Remove 5 screws from the backside of the Vignette frame cover and keep them aside (3 at bottom and 2 at top).

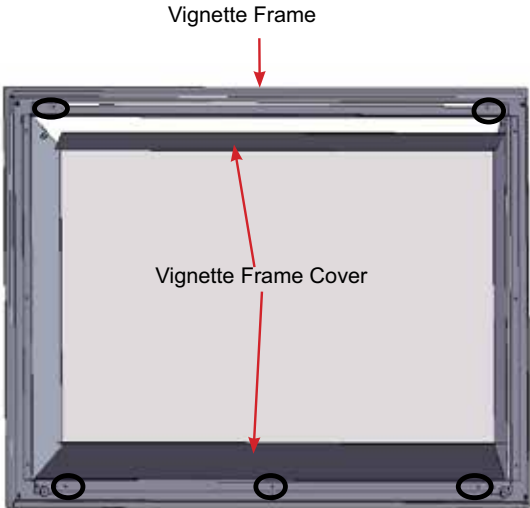

- 2. Take the mesh screen out of the Vignette front frame as shown below.

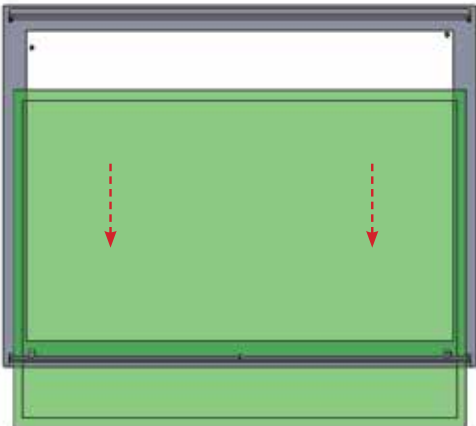

- 3. Place the Inlay on the Front Trim Assembly.

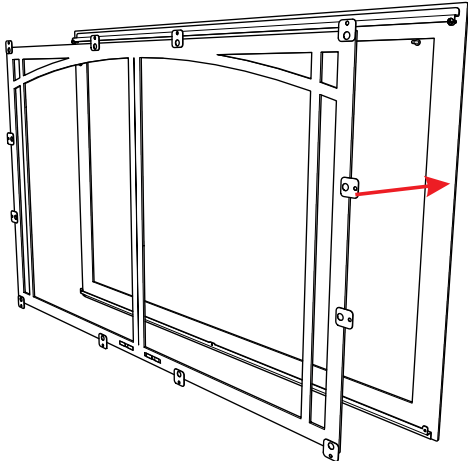

- 4. Center the inlay inside the Front Trim Assembly

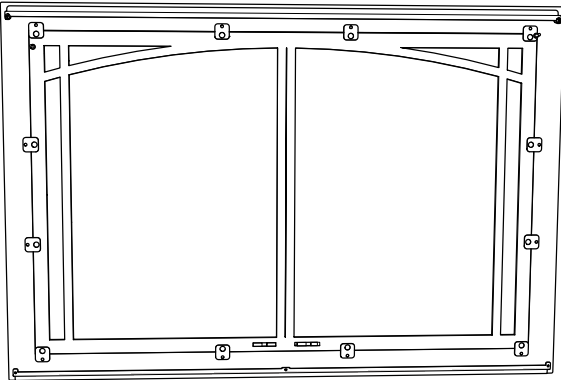

# installation

5. With the Inlay in position, place the mesh screen over the inlay.

**NOTE: The flush side of the mesh screen should face the inlay.**

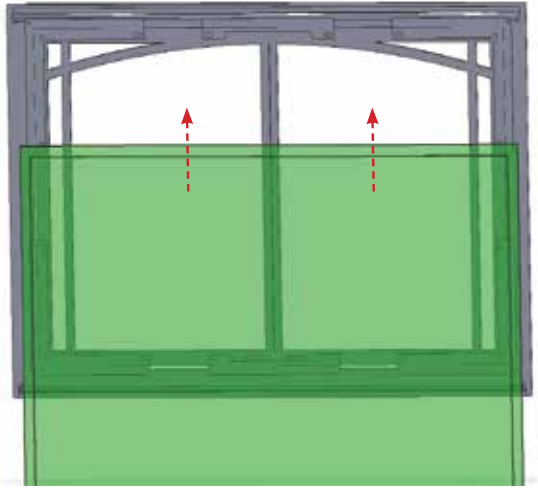

6. Reverse step1.

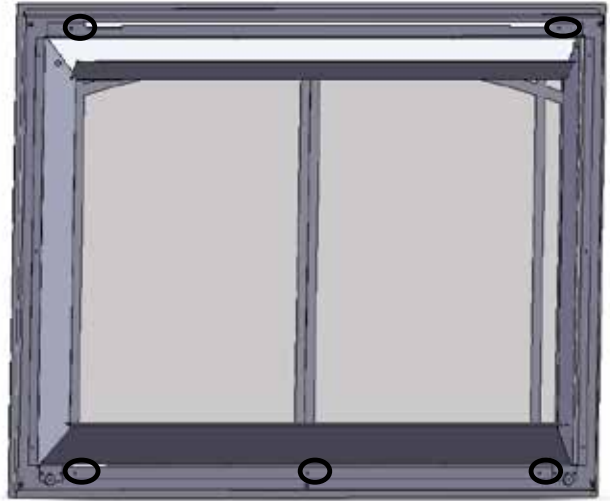

7. Install the Vignette frame with Inlay onto the 2 hooks provided on the unit.

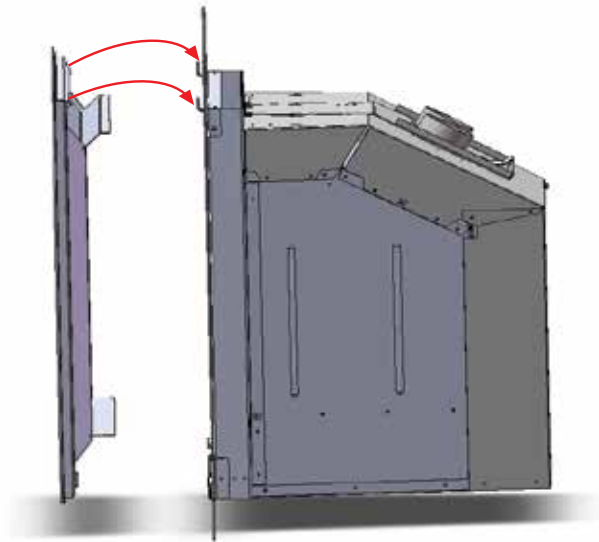

**BACKING PLATE INSTALLATION**

1. Remove Vignette (front) faceplate from unit and lay on a soft \ surface.



*Remove Front Faceplate*

2. Remove the back faceplate by removing the 4 screws as shown.

**Note:** the two top and two bottom screws can be loosened - slide the back faceplate up on out to remove.

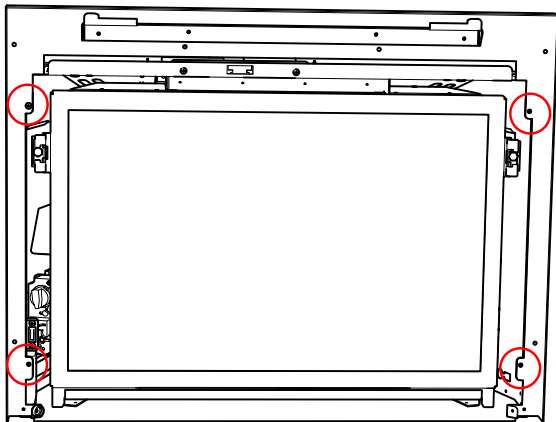

*Remove Back Faceplate*

3. Attach the backing plate to the back faceplate from the front with 6 screws (4 along the top and 1 on each side).

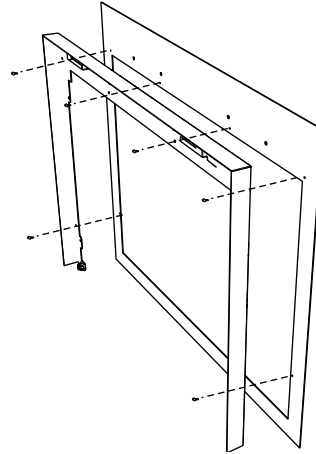

*Backing Plate Install*

4. Reinstall the back faceplate with backing plate—reverse Step 2.
5. Reinstall the Vignette faceplate and safety screen to complete.

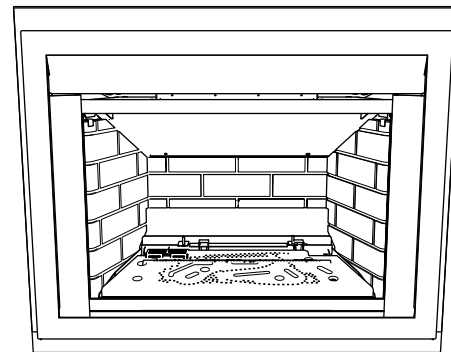

*Final Install-shown with 4 sided backing plate*

# installation

## OPTIONAL ARCHED VIGNETTE FACEPLATE INSTALLATION

1. Shut off unit and allow to return to room temperature
2. Install 4 supplied screws (loosely) onto unit in locations shown below.

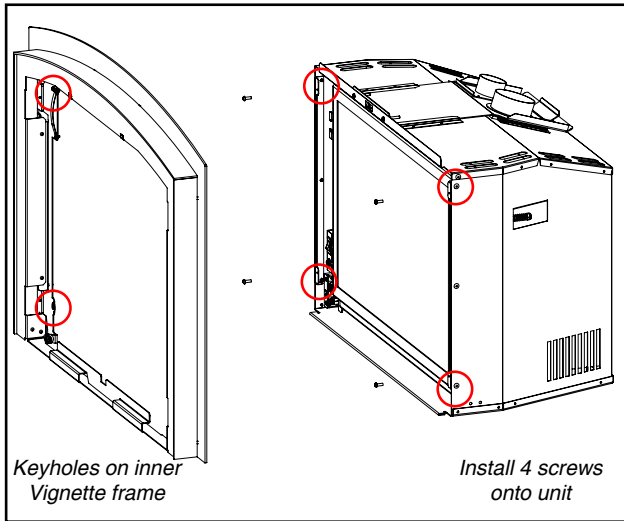

3. Install the inner Vignette frame by hanging the frame off the 4 screws via the keyhole openings on the frame. When in position, tighten the 4 screws.

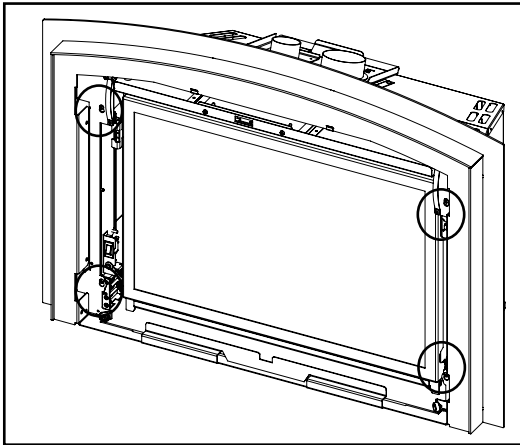

4. Install the safety screen into the inner Vignette frame by slightly tilting the safety screen frame and placing it up into the Vignette frame. Let the safety screen slightly drop down into position within the Vignette frame. The bottom of the screen will be held in position by magnets.

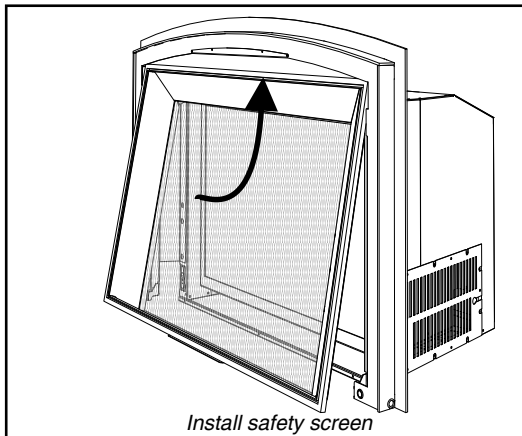

5. Install the outer Vignette frame onto the inner Vignette frame by hanging tabs into slots on inner Vignette frame.

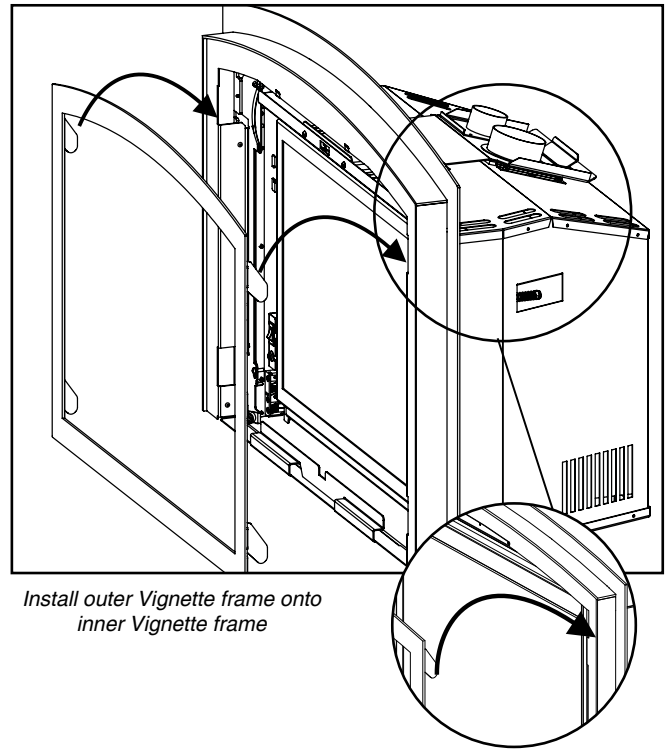

6. Route power cord to a near by receptacle on left hand side prior to sliding appliance into final position.

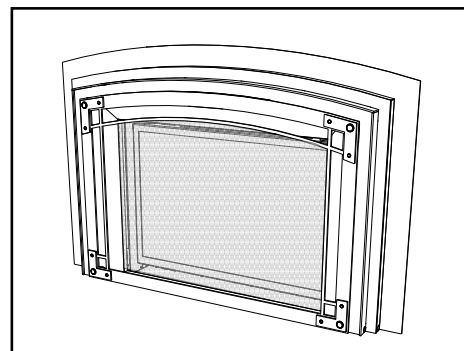
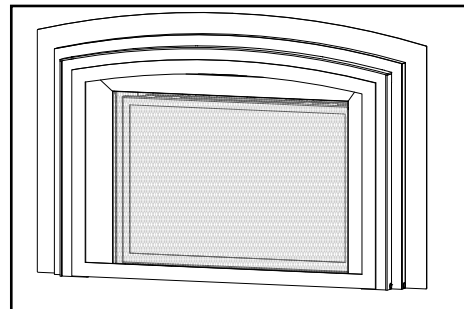

## OPTIONAL BACKING PLATE INSTALLATION

1. Shut off unit and allow to return to room temperature
2. Attach the backing plate with 4 screws from the back of the Vignette frame.

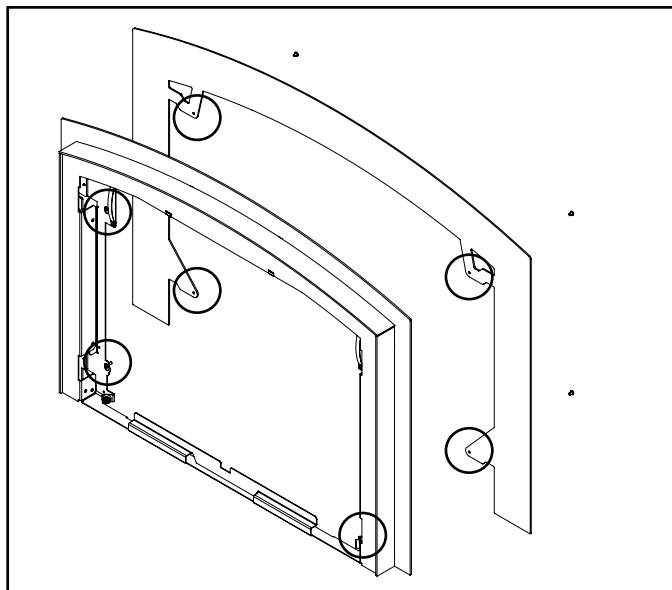

*Install backing plate to inner Vignette frame with 4 screws*

3. Install the backing plate + inner Vignette frame and outer Vignette frame as per Arched Vignette frame instructions.

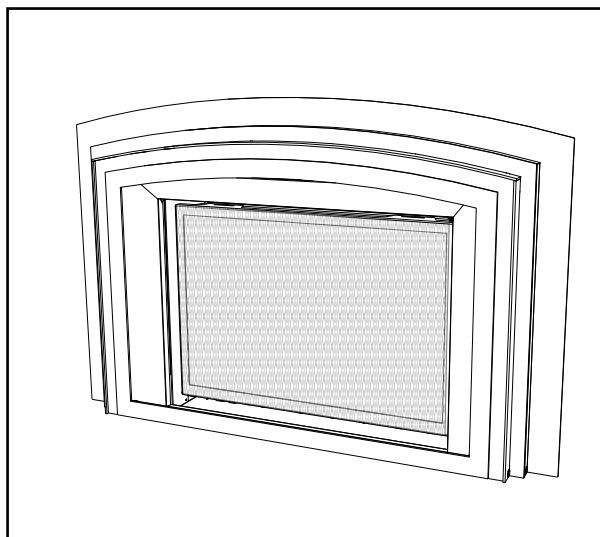

*Completed Arch Vignette Faceplate with spacer and backing plate installed*

# installation

## OPTIONAL HEARTH TRIM INSTALLATION

### Customizing the Hearth Trim

The Hearth Trim can be adjusted to custom fit an installation by pulling apart the top piece from the bottom piece. Minimum height of the hearth trim is 2" and can be adjusted up to maximum 6".

1. Cut the top of the bottom piece of the hearth trim to the appropriate height using a metal cutting blade.

**NOTE:** The tab bends at the back of the top piece of the hearth trim should be used as the measuring point to the hearth to measure the height required.

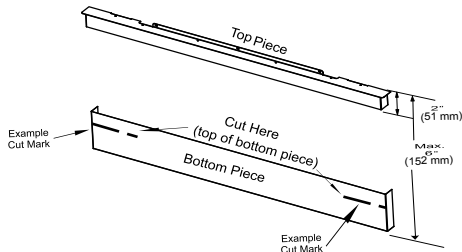

2. Reattach the top piece of the hearth trim to the cut bottom piece by fitting in place and secure with supplied clips, one on each side.

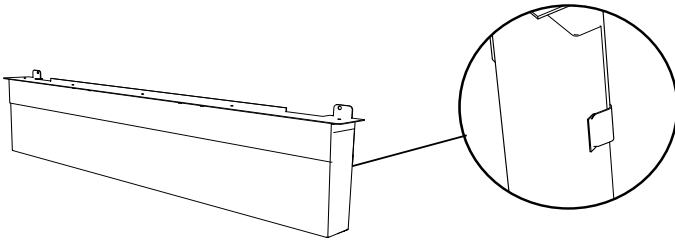

3. Ensuring back faceplate is in place - line up the hearth trim with base of the unit and secure it with 2 screws as shown below.

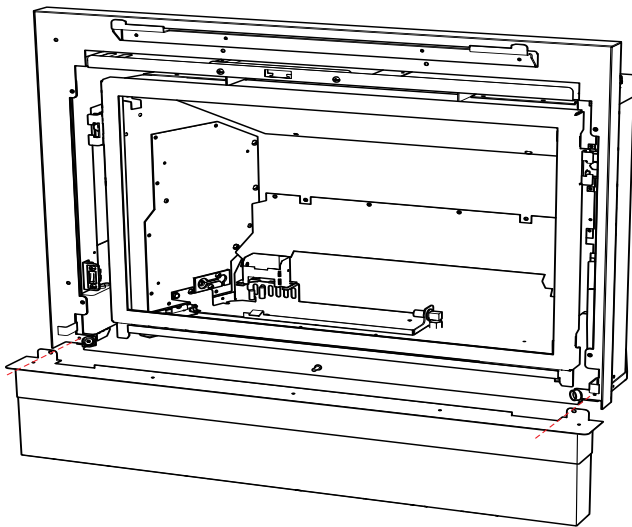

## OPTIONAL MANTEL DEFLECTOR INSTALLATION

A mantel deflector may be installed to reduce the minimum mantel height. Refer to the instruction manual for minimum mantel clearances.

1. Remove the outer faceplate if already installed.

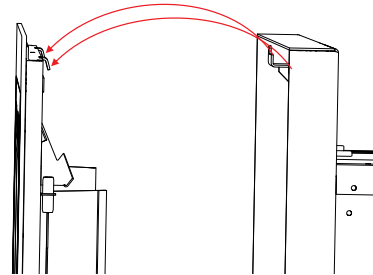

2. Remove back faceplate by removing 4 screws in locations shown below.

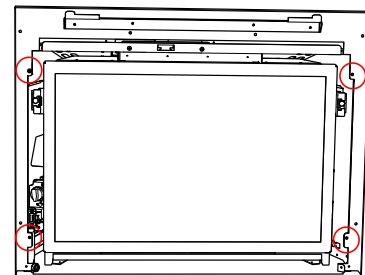

3. Install mantel deflector onto the back side of the back faceplate with 2 screws as shown below.

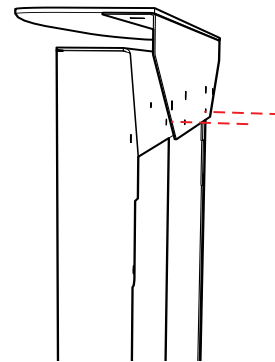

4. Reverse steps 2 & 1 to complete install.

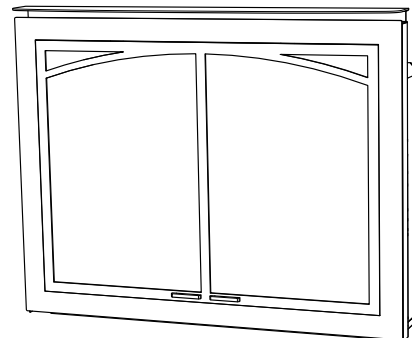

## FIRST FIRE

The first fire in your fireplace is part of the paint curing process. To ensure that the paint is properly cured, it is recommended that you burn your fireplace for at least four (4) hours the first time you use it with the fan on. When first operated, the unit will release an odour caused by the curing of the paint, the burning off of any oils remaining from manufacturing. Smoke detectors in the house may go off at this time. Open a few windows to ventilate the room for a couple of hours.

The glass panel may require cleaning after the unit has cooled down.

## DO NOT ATTEMPT TO CLEAN THE GLASS WHILE IT IS HOT.

**Note:** When the glass is cold and the appliance is lit, it may cause condensation and fog the glass. This condensation is normal and will disappear in a few minutes as the glass heats up.

**During the first few fires, a white film may develop on the glass front as part of the curing process. The glass should be cleaned or the film will bake on and become very difficult to remove. Use a non-abrasive cleaner and NEVER clean the glass while it is hot.**

**DO NOT BURN THE APPLIANCE WITHOUT THE GLASS FRONT IN PLACE.**

## OPERATING INSTRUCTIONS

1. Read and understand these instructions before operating this appliance.
2. Check to see that all wiring is correct and enclosed to prevent possible shock.
3. Check to ensure there are no gas leaks.
4. Make sure the glass in the door frame is properly positioned. Never operate the appliance with the glass removed.
5. Verify that the venting and cap are unobstructed.
6. Verify log placement. If the pilot cannot be seen when lighting the unit, the logs have been incorrectly positioned.
7. The unit should never be turned off, and on again without a minimum of a 60 second wait.

8. Remote control requires coding. See remote coding instructions for details.

**NOTE:** This appliance will operate with 4 AA back-up batteries installed (see Back-up Battery section for details) during power outages. Only the fan and light will not operate until power is restored. If the remote is misplaced, the unit can be shut off by flipping the main ON/OFF switch, located behind the the faceplate, to the OFF position.

**IMPORTANT:** The remote control system supplied with this appliance has several options for starting/operating the appliance, please read the remote control operating instructions (packed with remote control) to understand how to operate this remote system.

## CODING/PAIRING OF REMOTE CONTROL TRANSMITTER WITH ON/OFF SWITCH

1. Plug in 120 volt power. If power is not present proceed to step 1a.
- 1a. Install the 4 AA batteries into the battery holder. Note the polarity of the battery and insert into the battery bay as indicated on the Battery cover (+/-).
2. Ensure the main ON/OFF switch (located at lower left of unit) is in the <ON> position.

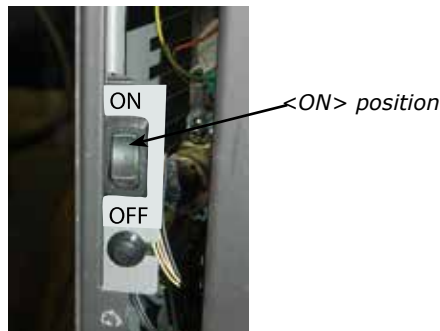

3. Press and release the black SYNC button (below the ON/OFF switch). The Receiver will "beep" three (3) times to indicate that it is ready to synchronize with a Transmitter.

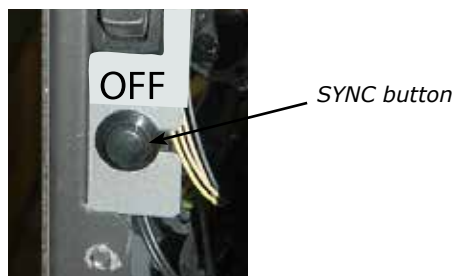

4. Install the 3 AAA type batteries in the Transmitter battery bay, located on the base of the Transmitter. With the batteries already installed in the Transmitter, push the <ON> button. The Receiver will "beep" four times to indicate the Transmitter's command is accepted and sets to the particular code of that Transmitter.

5. The system is now initialized.

## MANUAL OPERATION (NO REMOTE CONTROL)

To divorce the remote transmitter follow instructions below.

1. Press the black button on the lower left side (when facing unit) until it beeps 3 times.
2. Within 10 seconds press and hold the black button again until a beep is heard.
3. After divorcing the remote transmitter, the ON/OFF switch located at the lower left side of the appliance will control the unit.

# operating instructions

## NORMAL OPERATING SOUNDS OF GAS APPLIANCES

It is possible that you will hear some sounds from your gas appliance. This is perfectly normal due to the fact that there are various gauges and types of steel used within your appliance. Listed below are some examples. All are **normal operating sounds** and should not be considered as defects in your appliance.

### Blower:

Regency® gas appliances use high tech blowers to push heated air farther into the room. It is not unusual for the fan to make a "whirring" sound when ON. This sound will increase or decrease in volume depending on the speed setting of your fan speed control.

### Burner Tray:

The burner tray is positioned directly under the burner tube(s) and logs and is made of a different gauge material from the rest of the firebox and body. Therefore, the varying thicknesses of steel will expand and contract at slightly different rates which can cause "ticking" and "cracking" sounds. You should also be aware that as there are temperature changes within the unit these sounds will likely re-occur. Again, this is normal for steel fireboxes.

### Pilot Flame:

While the pilot flame is on it can make a very slight "whisper" sound.

### Gas Control Valve:

As the gas control valve turns ON and OFF, a dull clicking sound may be audible, this is normal operation of a gas regulator or valve.

### Unit Body/Firebox:

Different types and thicknesses of steel will expand and contract at different rates resulting in some "cracking" and "ticking" sounds will be heard throughout the cycling process.

## MAINTENANCE INSTRUCTIONS

1. Always turn off the valve before cleaning. For relighting, refer to lighting instructions. Keep the burner and control compartment clean by brushing and vacuuming at least once a year. When cleaning the logs, use a soft clean paint brush as the logs are fragile and easily damaged.

2. Clean glass (never when unit is hot), appliance, and door with a damp cloth. Never use an abrasive cleaner.

3. The heater is finished in a porcelain finish or with a heat resistant paint and should only be refinished with heat resistant paint (not with wall paint).

Never use an abrasive cleaner on the porcelain finish as it may scratch the surface.

4. Make a periodic check of burner for proper position and condition. Visually check the flame of the burner periodically, making sure the flames are steady; not lifting or floating. If there is a problem, call a qualified service person.

5. **Caution:** Label all wires prior to disconnection when servicing controls. Wiring errors can cause improper and dangerous operation.

6. The appliance and venting system must be inspected before use, and at least annually, by a qualified field service person, to ensure that the flow of combustion and ventilation air is not obstructed.

During the annual service call, the burner should be removed from the burner tray and cleaned. Replace the embers but do not block the pilot.

7. Keep the area near the appliance clear and free from combustible materials, gasoline, and other flammable vapours and liquids.

**WARNING: CHILDREN AND ADULTS SHOULD BE ALERTED TO THE HAZARDS OF HIGH SURFACE TEMPERATURE AND SHOULD STAY AWAY TO AVOID BURNS OR CLOTHING IGNITION. YOUNG CHILDREN SHOULD BE CAREFULLY SUPERVISED WHEN THEY ARE IN THE SAME ROOM AS THE APPLIANCE.**

**DO NOT USE THIS APPLIANCE IF ANY PART HAS BEEN UNDER WATER. IMMEDIATELY CALL A QUALIFIED SERVICE TECHNICIAN TO INSPECT THE APPLIANCE AND TO REPLACE ANY PART OF CONTROL SYSTEM AND ANY GAS CONTROL WHICH HAS BEEN UNDER WATER.**

**CAUTION: ANY SAFETY SCREEN OR GUARD REMOVED FOR SERVICING AN APPLIANCE MUST BE REPLACED PRIOR TO OPERATING THE APPLIANCE.**

**CLOTHING OR OTHER FLAMMABLE MATERIALS SHOULD NOT BE PLACED ON OR NEAR THE APPLIANCE.**

8. Each time the appliance is lit, it may cause condensation and fog the glass. This condensation and fog is normal and will disappear in a few minutes as the glass heats up.

**Never operate the appliance without the glass properly secured in place.**

9. Periodically check the pilot flames. Correct flame pattern has three strong blue flames: 1 flowing around the thermopile and 1 around the thermocouple, and 1 flowing across the rear of the burner (it does not have to be touching the burner).

**Note:** If you have an incorrect flame pattern, contact your Regency® dealer for further instructions.

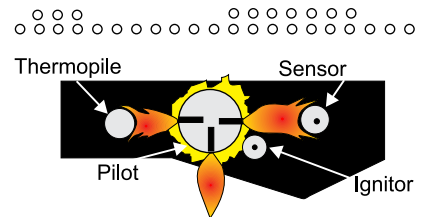

Top View of pilot flame

Incorrect flame pattern will have small, probably yellow flames, not coming into proper contact with the rear of the burner.

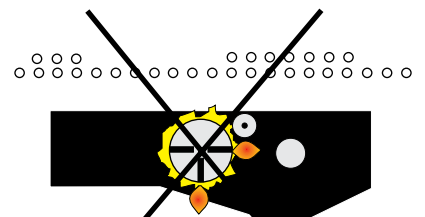

Top View of pilot flame

10. Verify operation after servicing.



## DOOR GLASS

Your Regency insert is supplied with high temperature, Neoceram ceramic glass that will withstand the highest heat that your unit will produce. If your glass requires cleaning, we recommend using an approved glass cleaner available at all authorized dealers. Do not use abrasive materials. Do not clean the glass when hot.

In the event that you break your glass by impact, purchase your replacement from an authorized Regency dealer only, and follow our step-by-step instructions for replacement.

**Warning: Do not operate appliance with glass panels removed, cracked or broken. Replacement of the glass should be done by a licensed or qualified service person.**

### CAUTION & WARNINGS:

- \* Do not clean when the glass is hot.
- \* The use of substitute glass will void all product warranties.
- \* Care must be taken to avoid breakage of the glass.
- \* Do not strike or abuse the glass.
- \* Do not operate this fireplace without the glass front or with a cracked or broken glass front.
- \* Wear gloves when removing damaged or broken glass.
- \* Replacement of the glass panel(s) should be done by a licensed or qualified service person.

### GLASS REPLACEMENT

In the event that you break your glass by impact, purchase your replacement from an authorized Regency® dealer only. Replacement Neoceram glass (Part # 940-454/P) is shipped with a gasket.

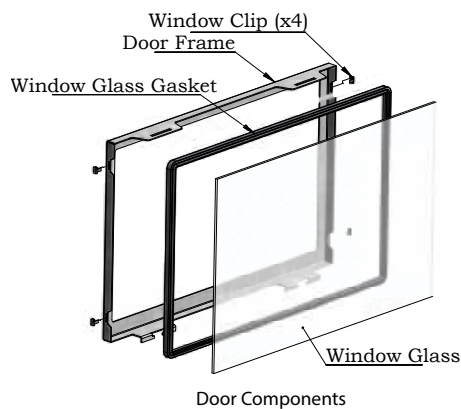

# maintenance

## PILOT ADJUSTMENT

Periodically check the pilot flames. Correct flame pattern has two strong blue flames: 1 flowing around the flame sensor and 1 flowing across the burner (it does not have to be touching the burner).

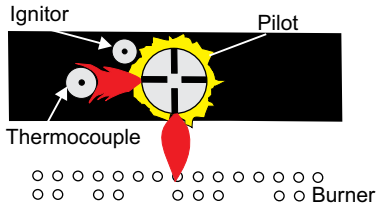

**Note:** If you have an incorrect flame pattern, contact your Regency® dealer for further instructions.

Incorrect flame pattern will have small, probably yellow flames, not coming into proper contact with the rear burner or flame sensor.

## GENERAL VENT MAINTENANCE

Conduct an inspection of the venting system semi-annually. Recommended areas to inspect as follows:

1. Check the Venting System for corrosion in areas that are exposed to the elements. These will appear as rust spots or streaks, and in extreme cases, holes. These components should be replaced immediately.
2. Remove the Termination Cap, and shine a flashlight down the Vent. Remove any bird nests, or other foreign material.
3. Check for evidences of excessive condensation, such as water droplets forming in the inner liner, and subsequently dripping out the joints. Continuous condensation can cause corrosion of caps, pipe, and fittings. It may be caused by having excessive lateral runs, too many elbows, and exterior portions of the system being exposed to cold weather.
4. Inspect joints, to verify that no pipe sections or fittings have been disturbed, and consequently loosened. Also check mechanical supports such as Wall Straps, or plumbers' tape for rigidity.

## LOG REPLACEMENT

The unit should never be used with broken logs. Turn off the gas valve and allow the unit to cool before opening door to carefully remove the logs. The pilot light generates enough heat to burn someone. If for any reason a log should need replacement, you must use the proper replacement log. The position of these logs must be as shown in the diagram under Log Installation.

NOTE: Improper positioning of logs may create carbon build-up and will alter the unit's performance which is not covered under warranty.

## GLASS GASKET

If the glass gasket requires replacement use glass gasket (Part # 846-697).

## BACKUP BATTERY PACK

There is a back up battery pack located on the left side of the unit, used in case of a power outage.

1. Remove battery pack from left side of unit (attached with velcro).
2. Install 4-AA batteries.
3. Reinstall battery pack on to unit.



## FAN REPLACEMENT - WITH REMOTE CONTROL

**Note:** To access the rear access panel both the gas and venting will need to be disconnected (see vent/flue installation in this manual) for proper removal. There is no access to the blower from the front of this appliance.

**Before you begin:**  
**Shut off the gas supply to the unit.**  
**Disconnect all electrical supply to the unit.**  
**Always let the appliance cool to room temperature before servicing.**

1. Remove 5 screws and loosen 2 screws along the bottom to remove fan access panel -see Diagram 1.

□ = Remove  
 ○ = Loosen

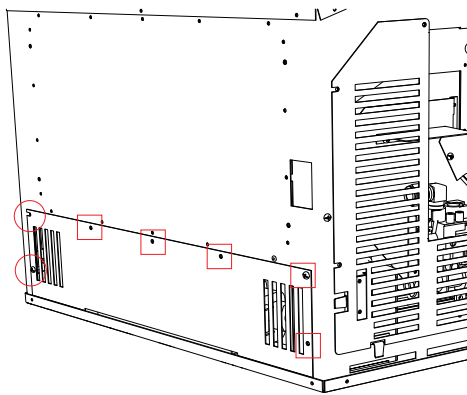

Diagram 1

2. Disconnect the fan wire harness through the rear panel. Disconnect 2 x 1/4" spade connectors to the fan terminals. Disconnect the ground lug to the fan using the screw provided.

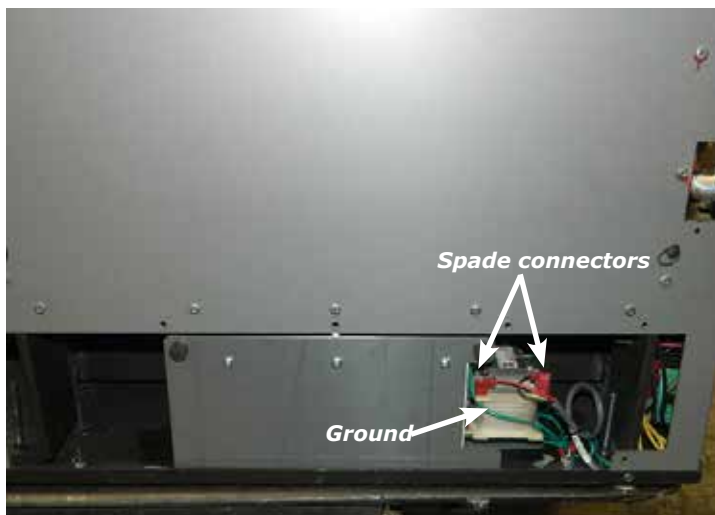

Diagram 2

3. Remove fan from unit by lifting up off pins.

4. To reinstall - reverse steps.

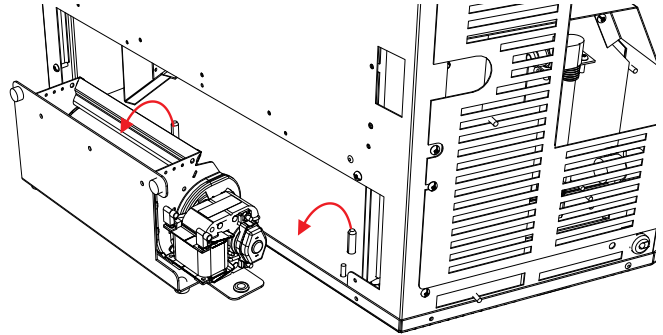

Diagram 3

### WARNING

**Electrical Grounding Instructions**  
 This appliance is equipped with a three-prong (grounding) plug for your protection against shock hazard and should be plugged directly into a properly grounded three-prong receptacle. Do not cut or remove the grounding prong from this plug.

# maintenance

## VALVE REPLACEMENT

### Before you begin:

\* Shut off the gas supply to the unit.  
Disconnect all electrical supply to the unit.

Always let the appliance cool to room temperature before servicing.

**Note:** To access the left control panel cover, the venting will need to be disconnected (see vent/flue installation in this manual) for proper removal.

1. Remove the Faceplate, glass door and inner panels - see instructions in this manual.
2. Remove the Left Control Panel Cover.

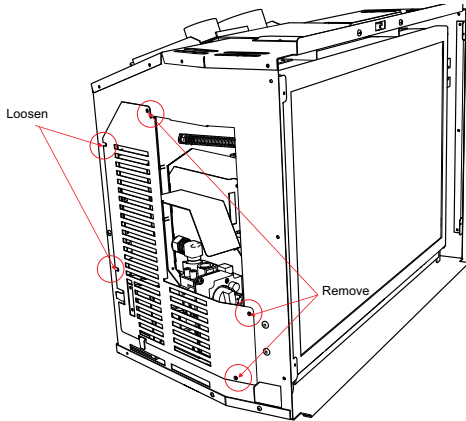

Diagram 1

3. Disconnect gas line from valve.
4. Remove the burner.

**LRI3E** - Remove the burner by removing 2 screws in locations shown below.



LRI3E Diagram 2

**HRI3E** - Remove the burner by removing 5 screws in locations shown below to remove burner cover and 2 screws to remove burner (shown below).

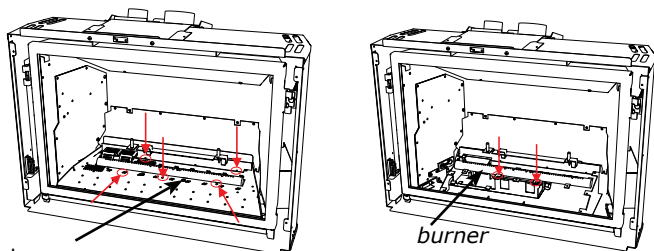

HRI3E Diagram 3

5. Remove the burner support by removing 3 screws as shown below.



Diagram 4

6. Remove the back deflector by removing 4 top screws and loosening 2 bottom screws.



Diagram 5

7. Remove the valve access plate by removing 11 screws on the side panel and 3 on the bottom as shown below.



Diagram 6

8. Lift out panel (part of valve assembly) with valve and pilot assembly.

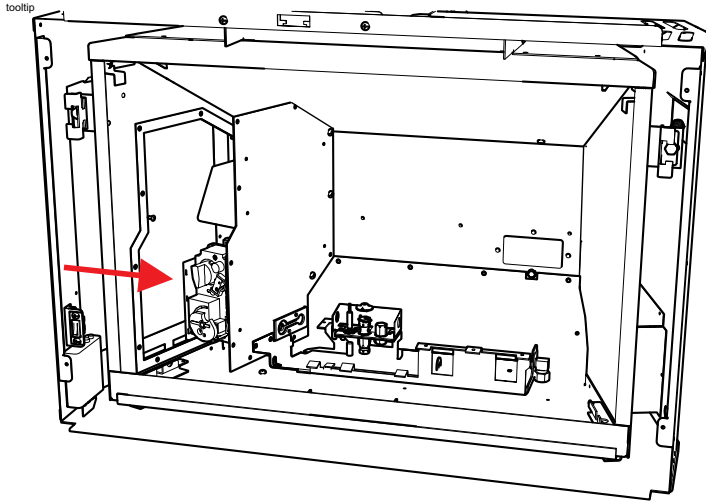

Diagram 7

9. Replace with new valve assembly, ensuring to use a new gasket before securing new valve access plate to unit.
10. Reassemble unit by reversing Steps 8-1.
11. Reconnect the gas and electrical supply to the unit. Once the unit has been refired, use a soapy water mixture to check all fitting and gas supply lines for gas leaks.

# maintenance

## GAS MAINTENANCE - RECOMMENDED ANNUAL ROUTINE

In order for your Regency appliance to continue to provide comfort to your home periodic maintenance must be performed to ensure it is operating at peak efficiency. The items in the list should be checked by a licensed gas service technician during the annual service check. Your unit may require more frequent maintenance checks if you notice any changes in how it operates. Operational changes to look for can include, but are not limited to, extended start up time, increased fan noise, residue/carbon build up, white build up on the glass/firebox, increased operating noise etc. Should any of these or other conditions arise, discontinue use and schedule a service check with your local licensed gas technician. The list below shows items your licensed service technician will need to check and service at least annually.

### Clean

- Glass
- Interior bricks / panels
- Burner ports & burner air shutter
- Fan blades
- Log set
- Pilot orifices
- Pilot hood (change as needed)
- Flame sensor (electronic ignition models)
- Flame electrode
- Burner orifice
- Thermocouple (millivolt models)
- Thermopile (millivolt models)

### Inspect

- Pilot assembly
- Burner
- Pressure relief gaskets/doors
- Flue connector gasket if present
- Door seal
- Firebox
- Venting
- Batteries (remote handheld, remote receiver, DC sparker, change as needed)
- Burner media (change as needed)
- Air shutter setting
- Wiring

### Check

- Voltage on thermocouple/thermopile (millivolt models)
- Ohms reading on flame sense (electronic ignition models)
- Inlet/outlet fuel pressures as per rating plate
- Voltage/ohms readings on gas valve
- Ohms reading to on/off switch circuit (Millivolt models)

### Gas Leak Tests

- Check main gas line connection to valve
- Check shut off valve connections
- Check connection at gas valve outlet
- Check connection at main burner orifice
- Check pilot fuel line at valve and at pilot assembly

## LRI3E-11 PARTS LIST

	Part #	Description
1	717-574/P	Valve Assembly - NG
1	717-776/P	Valve Assembly - LP
2	911-084	Novasit 885 Valve - NG IPI 885.001
2	911-085	Novasit 885 Valve - LP IPI 885.002
3	911-010	Stepper Motor/Modulator - NG 0.907.013
3	911-011	Stepper Motor/Modulator - LP 0.907.012
4	911-276	Pilot Assembly IPI NG 2 Flame 0.199.050
4	911-277	Pilot Assembly IPI LP 2 Flame
5	910-036	Orifice SIT Pilot - NG #51 977.165
5	910-037	Orifice SIT Pilot - LP #30 977.167
6	911-039	2 Way Pilot Hood
7	911-137	Pilot Hood Clip
8	911-037	Novasit Flame Sense
9	911-038	Novasit Flame Electrode
10	910-432	Novasit Pilot Tubing With Nuts
11	466-081	Pilot Shield
12	910-246	Switch 2 Way Gold Contact
13	911-027	Battery Holder W/9V Snap 4 Cell Horz AA
14	911-242	Reset Switch With Wire & Connector
15	716-011	Firebox Baffle
16	716-017	Rear Inner Air Deflector
17	716-539	Rear Log Tray Assembly
18	716-079F	Plate - Fan Access
19	716-515	Flue Adaptor Assembly
20	716-076	Flue Adaptor Gasket
21	911-207/P	Fan Motor Only Including Squirell Cage
22	716-530	Ceramic Burner Assembly NG/LP
23	716-012	Door Frame Only - No Glass
24	940-454/P	Replacement Glass - Include Gasket (Size: 24 1/8 " W. X 15 11/16" H.)
25	846-697	Glass Gasket Tadpole Tape (12') (936-155)
26	717-002	Left Side Valve Cover Plate
27	717-005	Outer Valve Cover Plate
28	904-655	Burner Orifice #45 NG
28	904-575	Burner Orifice #55 LP
N/S	932-017	Tubing SS Flexible 3/8 x 17 inch
N/S	904-599	Fitting Elbow 90 Degree

	Part #	Description
N/S	904-629	Fitting Elbow 90 Degree Forged
N/S	904-606	Fitting 90 Street Elbow Extruded
N/S	904-658	Inlet Flex Line Gas SS Steel 24 inch
N/S	716-034F	Side Firebox Bracket
N/S	716-046	Valve Assembly Gasket
N/S	936-221	Orange Gasket (Side Firebox)
	Part #	Description
N/S	911-266/P	IFC Board SIT Proflame II 7day PV+5 Sec. FFRT 0.584.625
N/S	911-175	Hand Held Remote Control GTMFL SIT 0.584.042
N/S	911-178	Wire 2 Pos IFC Burner On/Off
N/S	396-105	Spring Pressure Relief Door 4.5 in. x 0.5 in.
N/S	716-016	Brick Clip (Each)
N/S	716-038	Firebox Base Deflector
N/S	716-537	Door Latch Assembly (Each) Includes Spring
N/S	716-067F	Flue Restrictor Plate
N/S	911-179	Power Cord IFC Proflame II 120 Volts
N/S	911-180	Wire Fan On/Off Grey
N/S	911-257	Wire Harness 4 Position IFC Fan
N/S	716-930	Log Set - Complete
N/S	904-751	Leveling Bolt 1/4-20 x 4-1/2 Hex Hd Zinc Pd Gr.5
N/S	904-691	Glass Clip-U
N/S	396-042F	Glass Door Frame Tool
N/S	716-018	Side Panel Guide (Each)
N/S	717-003	On/Off/Reset Switch Bracket
N/S	908-529	Label Natural Gas Yellow
N/S	908-528	Label Propane Red
N/S	716-010	Replacement Safety Screen (Vignette Faceplate)

# parts list

## LRI3E-11 MAIN ASSEMBLY

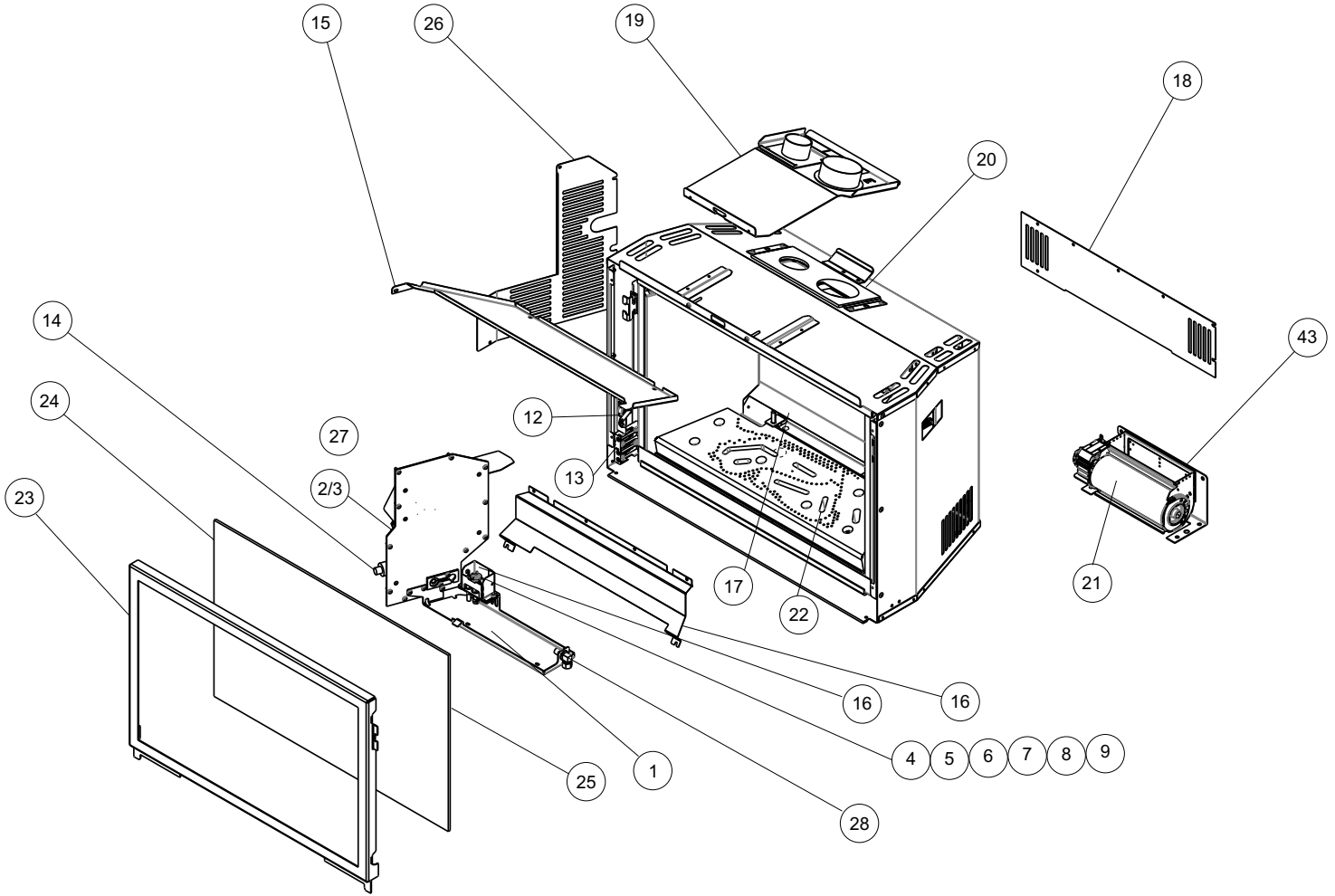



**HRI3E-11 PARTS LIST**

	Part #	Description
1	717-578/P	Valve Assembly - NG
1	717-780/P	Valve Assembly - LP
2	911-084	Novasit 885 Valve - NG IPI 885.001
2	911-085	Novasit 885 Valve - LP IPI 885.002
3	911-010	Stepper Motor/Modulator - NG 0.907.013
3	911-011	Stepper Motor/Modulator - LP 0.907.012
4	911-006	Pilot Assembly IPI NG 2 Flame 0.199.050
4	911-277	Pilot Assembly IPI LP 2 Flame
5	910-100	Orifice SIT Pilot - NG #62 977.166
5	910-037	Orifice SIT Pilot - LP #30 977.167
6	911-039	2 Way Pilot Hood
7	911-137	Pilot Hood Clip
8	911-037	Novasit Flame Sense
9	911-038	Novasit Flame Electrode
10	910-432	Novasit Pilot Tubing With Nuts
11	466-081	Pilot Shield
12	910-246	Switch 2 Way Gold Contact
13	911-027	Battery Holder W/9V Snap 4 Cell Horz AA
14	911-242	Reset Switch With Wire & Connector
15	716-011	Firebox Baffle
18	716-079F	Plate - Fan Access
19	716-515	Flue Adaptor Assembly
20	716-076	Flue Adaptor Gasket
21	911-207/P	Fan Motor Only Including Squirell Cage
22	911-266/P	IFC Board SIT PF II 7 day PV + 5 Sec. FFRT 0.584.625
23	716-012	Door Frame Only - No Glass
24	940-454/P	Replacement Glass - Include Gasket (Size:24 1/8 " W. X 15 11/16" H.)
25	846-697	Glass Gasket Tadpole Tape (12') (936-155)
26	717-002	Left Side Valve Cover Plate
27	717-005	Outer Valve Cover Plate
28	904-655	Burner Orifice #45 NG
28	904-575	Burner Orifice #55 LP
29	716-525	Burner Tube Assembly NG/LP
30	716-039	Burner Cover/Tray
N/S	932-017	Tubing SS Flexible 3/8 x 17 inch
N/S	904-599	Fitting Elbow 90 Degree

	Part #	Description
N/S	904-629	Fitting Elbow 90 Degree Forged
N/S	904-606	Fitting 90 Street Elbow Extruded
N/S	904-658	Inlet Flex Line Gas SS Steel 24 inch
N/S	716-034F	Side Firebox Bracket
N/S	716-046	Valve Assembly Gasket
N/S	936-221	Orange Gasket (Side Firebox)
N/S	911-175	Hand Held Remote Control GTMFL SIT 0.584.042
N/S	911-178	Wire 2 Pos IFC Burner On/Off
N/S	396-105	Spring Pressure Relief Door 4.5 in. x 0.5 in.
N/S	716-016	Brick Clip (Each)
N/S	716-038	Firebox Base Deflector
N/S	716-537	Door Latch Assembly (Each) Includes Spring
N/S	716-067F	Flue Restrictor Plate
N/S	911-179	Power Cord IFC Proflame II 120 Volts
N/S	911-180	Wire Fan On/Off Grey
N/S	911-257	Wire Harness 4 Position IFC Fan
N/S	716-935/P	Driftwood Log Set - Complete
N/S	904-751	Leveling Bolt 1/4-20 x 4-1/2 Hex Hd Zinc Pd Gr.5
N/S	904-691	Glass Clip-U
N/S	396-042F	Glass Door Frame Tool
N/S	716-018	Side Panel Guide (Each)
N/S	717-003	On/Off/Reset Switch Bracket
N/S	908-529	Label Natural Gas Yellow
N/S	908-528	Label Propane Red
N/S	716-010	Replacement Safety Screen (Vignette Faceplate)

# maintenance

## HRI3E-11 MAIN ASSEMBLY

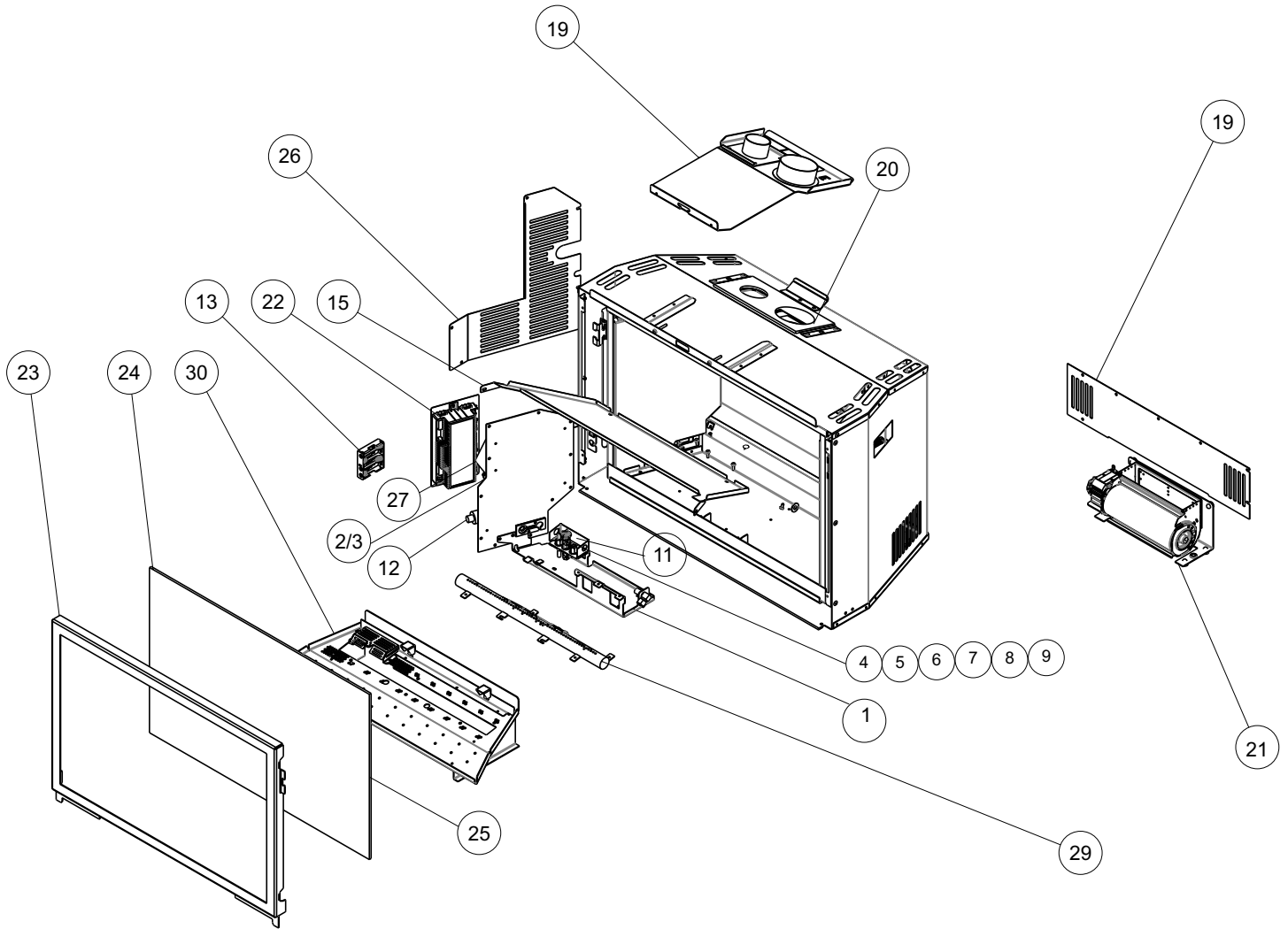

**ACCESSORIES**

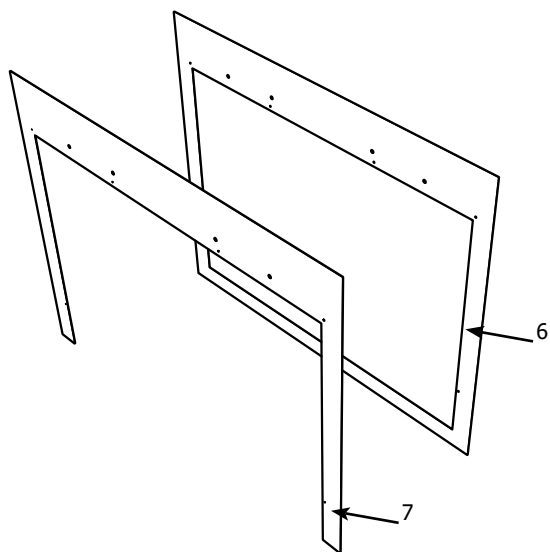
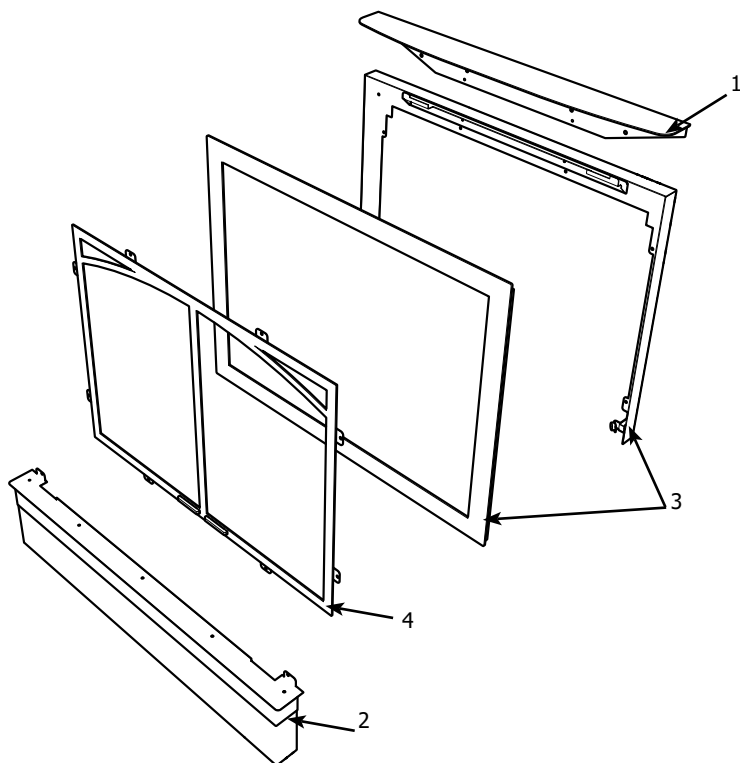

#	Part #	Part Description
1	716-920	Mantel Deflector
2	716-919	Hearth Trim Adjustable
3	716-921	Faceplate Vignette Tuscan Sunset
	716-922	Faceplate Vignette Black Chrome
	716-923	Faceplate Vignette Metallic Black
	716-924	Faceplate Vignette Platinum
6	716-928	Backing Plate 4-Sided Vignette
7	716-925	Backing Plate Vignette Small
	716-926	Backing Plate Vignette Regular
	716-927	Backing Plate Vignette Oversize
	Not shown	
	716-901	Brick Panel Standard Brown (LRI3 only)
	716-902	Brick Panel Standard Red (LRI3 only)
	716-703	Brick Panel Standard Black (LRI3 only)
	716-908	Inner Panel Black Enamel
	716-911	Vignette Door Inlay Tuscan Sunset
	716-912	Vignette Door Inlay Black Chrome
	716-913	Vignette Door Inlay Metallic Black
	716-914	Vignette Craftsman Inlay Tuscan Sunset
	716-915	Vignette Craftsman Inlay Black Chrome
	716-916	Vignette Craftsman Inlay Metallic Black
	716-925	Backing Plate Vignette Small
	716-926	Backing Plate Vignette Regular
	716-927	Backing Plate Vignette Oversize
	716-931	Backing Plate Custom 3-Sided Vignette
	716-932	Backing Plate Custom 4-Sided Vignette
	716-933	Faceplate Vignette Georgian Metallic Black
	716-934	Faceplate Vignette Georgian Iron Gray
	717-843	Faceplate Arched Vignette Metallic Black
	717-845	Faceplate Decorative Arched Vignette Metallic Black
	717-847	Backing Plate Arched Vignette
	717-977	Conversion Kit LP
	717-968	Conversion Kit NG
	HRI3E only	
	946-672	Stones - River Pebbles
	946-974	Stones - Ceramic Spa (70 stones)
	946-675	Fireglass Black Reflective 1/4in.1Lb Pkg
	946-676	Fireglass Copper 1/4 in. 1Lb Pkg
	946-677	Fireglass Starfire 1/4 in. 1Lb Pkg
	946-775	Fireglass Black Reflective 1/4in.5Lb Pkg
	946-776	Fireglass Copper 1/4 in. 5Lb Pkg
	946-777	Fireglass Starfire 1/4 in. 5Lb Pkg
	946-780	Crushed Glass Coal Black 3/4in. 3.5 Lbs
	946-781	Crushed Glass Iceberg Chips 3/4in. 3.5 Lbs
	946-735	Firebeads Black 1 Lb Pkg
	946-736	Firebeads Sangria Luster 1 Lb Pkg
	946-737	Firebeads Glacier Ice 1 Lb Pkg
	946-738	Firebeads Caramel Luster 1 Lb Pkg
	946-739	Firebeads Black 5 Lb Pkg

## Indoor Gas Product Warranty

### Limited Lifetime Warranty

FPI Fireplace Products International Ltd. (for Canadian customers) and Fireplace Products US, Inc. (for US customers) (collectively referred to herein as “FPI”) extends this Limited Lifetime Warranty to the original purchaser of this Appliance provided the product remains in the original place of installation. The items covered by this Limited Lifetime Warranty and the period of such coverage are set forth in the table below.

An Appliance in this policy is defined as an Indoor Gas Fireplace, Indoor Gas Insert, Indoor Gas Freestanding Stove.

**This Appliance has only been certified and listed for use indoors.**

This Limited Lifetime Warranty starts on the day the Appliance was purchased.

**The Limited Lifetime Warranty is not transferable, amendable or negotiable under any circumstances.**

Indoor Gas Products Warranty Coverage Parts and Labor	Limited Lifetime	5 years	2 years	1 year	Subsidized Labor Coverage* (Years)
Firebox and Heat Exchanger	✓				3
Steel Burner Tube	✓				3
Glass Thermal breakage only	✓				3
All painted Surrounds/Inlays Finishes		✓			3
Brick Panels/Log sets/Ceramic Burners		✓			3
All Castings		✓			3
Valve assembly and all gas control components (Pilot assembly, flame sensors, Spark Electrode, Pilot Tubing, Orifices, Thermocouple, Thermopile)			✓		2
All Other Electrical components (Ignition Control Boards, Wiring, Switches, Blowers, Blower Control Module, Battery Pack, Remote Control Systems)			✓		2
Enamel Panels			✓		1
Venting/Venting Components			✓		1
All Stainless steel surrounds All black chrome Brushed nickel/Antique copper Faceplates/surrounds All Inner/Outer Black Glass panels				✓	1
All Firebox Media (Crystals, Fire beads, Volcanic, Ceramic, Spa Stones, River Pebbles)				✓	1
All hardware				✓	1
WIFI Dongle				✓	1
Mesh/Glass Safety Barriers				✓	1
Accent Light Bulbs				✓	1
Glass (Crazing)				✓	1

**Note:** Warranty coverage noted above may not be applicable as components/options vary based on appliance purchased.

### Conditions:

Warranty protects against defect in manufacture or FPI factory-assembled components only, unless herein specified otherwise.

**\*This warranty does not cover dealer travel costs, mileage, fuel, tolls for diagnostic or service work. All labor rates paid to authorized dealers are subsidized, pre-determined rates. Dealers may charge you for travel and additional time beyond their subsidy.**

Any part(s) found to be defective during the warranty period as outlined above will be repaired or replaced at FPI's option through an accredited distributor, dealer or pre-approved and assigned agent; provided that the defective part is returned to the distributor, dealer or agent for inspection if requested by FPI. Alternatively, FPI may, at its discretion, fully discharge all of its obligations under warranty by refunding the verified purchase price of the product to the original purchaser. The purchase price must be confirmed by the original Bill of Sale. **The authorized selling dealer, or an alternative authorized FPI dealer if pre-approved by FPI, is responsible for all in-field diagnosis and service work related to all warranty claims. FPI is not responsible for results or costs of workmanship of unauthorized FPI dealers or agents in the negligence of their service work.**

At all times, FPI reserves the right to inspect reported in the field/on location complaints of products claimed to be defective before processing or authorizing any claim. Failure to allow this upon request will void the warranty.

All warranty claims must be submitted by the dealer servicing the claim, including a copy of the Bill of Sale (proof of purchase by you). All claims must be complete and provide full details as requested by FPI to receive consideration for evaluation. **Incomplete claims may be rejected.**

**Replacement Appliances to the original purchaser are limited to one per warranty term.** Appliances must be installed according to all manufacturers' instructions as per the manual. All Local and National required codes must be met.

The installer is responsible for ensuring the Appliance is operating as designed at the time of installation.

The original purchaser is responsible for the annual maintenance of the Appliance, as outlined in the owner's manual. As outlined below, the warranty may be voided due to problems caused by a lack of maintenance.

Purchased parts: Repair/replacement parts purchased by the consumer from FPI after the original coverage has expired on the Appliance will carry a **90-day** warranty from the purchase date, valid with a receipt only. Any item shown to be defective will be repaired or replaced at our discretion. No labor coverage is included with these parts.

Special Finishes - One year on brushed nickel, black chrome and antique copper faceplates/surrounds. You can expect some changes in color as the product "ages" with constant heating and cooling. FPI warrants the product for any manufacturing defects on the original product. However, the manufacturer's warranty does not cover changing colors and marks, i.e. fingerprints, etc. applied after the purchase of the product. Damage from the use of abrasive cleaners is not covered by warranty.

If freight damage has been found either externally or internally, the dealer must be informed within 3 days. All claims as a result of damage must be submitted by the dealer servicing the claim, including a copy of the Bill of Sale (proof of purchase). All claims must be complete and provide full details as requested by FPI to receive consideration for evaluation. **Incomplete claims may be rejected.**

As this is a Limited Lifetime Warranty, if the Appliance needs to be replaced, the Appliance that was purchased at the time of sale might not be replaced with exactly the same model Appliance. In that case, FPI will replace your Appliance with one that is similar at the time of replacement under the terms of this Limited Lifetime Warranty, but **ONLY** in the event that an item covered by the Limited Lifetime Warranty is found to be defective. Please refer to the table on first page of this warranty for items covered by the Limited Lifetime Warranty. Product changes might be the result of the original Appliance being discontinued, changes in regulatory requirements, product advancements, etc., which are beyond the control of FPI. **This Limited Lifetime Warranty does not cover any installation costs, or costs associated with changes of required clearances for the replacement Appliance, hearth pads, mantles, facing and/or facing materials such as framing, completed walls made of drywall, wood, non-combustible board, tile, brick, stone, marble etc., venting/chimney systems, or components of the chimney system.**

If a suitable replacement is not available, FPI will refund **50%** of the purchase price of the Appliance and any applicable FPI accessories (faceplates, brick panels, media, etc.) purchased at the time of sale. **In no event will FPI refund any portion of the purchase price of, or reimburse costs associated with, any other items, including without limitation, installation of a new Appliance, changes of required clearances for a new Appliance, hearth pads, mantles, facing and/or facing materials such as framing, completed walls made of drywall, wood, non-combustible board, tile, brick, stone, marble etc., venting/chimney systems, or components of the chimney system. A copy of the receipt or bill of sale will be necessary to validate the purchase price.**

# warranty

## **Exclusions:**

This Limited Lifetime Warranty does not extend to paint, rust or corrosion of any kind due to a lack of maintenance or improper venting, combustion air provision, corrosive chemicals (i.e. chlorine, salt, air, etc.), door or glass gasketing, batteries, color fading, carbon/sooting of the log sets due to use and does not cover lava rock, platinum/glowing embers, vermiculite.

Malfunction, damage or performance-based issues as a result of environmental conditions, location, chemical damages, downdrafts, installation error, an installation by an unqualified installer, incorrect chimney components (including but not limited to cap size or type), operator error, abuse, misuse, use of improper fuels, lack of regular maintenance and upkeep, acts of God, weather-related problems from hurricanes, tornados, earthquakes, floods, lightning strikes/bolts or acts of terrorism or war, which result in a malfunction of the Appliance are not covered under the terms of this Limited Lifetime Warranty.

FPI has no obligation to enhance or modify any Appliance once manufactured (i.e. as products evolve, field modifications or upgrades will not be performed on existing Appliances).

Any Appliance showing signs of neglect or misuse will not be covered under the terms of this warranty policy and may void this warranty, including Appliances with rusted or corroded fireboxes that have not been reported as rusted or corroded within **three (3)** months of installation/purchase.

Appliances which show evidence of being operated while damaged, or with problems known to the purchaser and causing further damages will void this warranty.

Appliances where the serial no. has been altered, deleted, removed or made illegible will void this warranty.

Minor movement, expansion and contraction of the steel is normal and is not covered under the terms of this warranty.

Freight damages for products or parts are not covered under the terms of the warranty.

Products made or provided by other manufacturers and used in conjunction with the FPI Appliance without prior authorization from FPI may void this warranty.

## **Limitations of Liability:**

The original purchaser's exclusive remedy under this warranty, and FPI's sole obligation under this Limited Lifetime Warranty, express or implied, in contract or in tort, shall be limited to replacement, repair, or refund, as outlined above. IN NO EVENT WILL FPI BE LIABLE UNDER THIS WARRANTY FOR ANY INCIDENTAL OR CONSEQUENTIAL COMMERCIAL DAMAGES OR DAMAGES TO PROPERTY. TO THE EXTENT PERMITTED BY APPLICABLE LAW, FPI MAKES NO EXPRESS WARRANTIES OTHER THAN THE WARRANTY SPECIFIED HEREIN. THE DURATION OF ANY IMPLIED WARRANTY IS LIMITED TO DURATION OF THE EXPRESSED WARRANTY SPECIFIED ABOVE. IF IMPLIED WARRANTIES CANNOT BE DISCLAIMED, THEN SUCH WARRANTIES ARE LIMITED IN DURATION TO THE DURATION OF THIS WARRANTY.

Some US states do not allow limitations on how long an implied warranty lasts, or allow exclusion or limitation of incidental or consequential damages, so the above limitations or exclusions may not apply to you.

Customers located outside the US should consult their local, provincial or national legal codes for additional terms, which may apply to this warranty.

**How to Obtain Warranty Service:**

Customers should contact the authorized selling dealer to obtain warranty service. In the event the authorized selling dealer is unable to provide warranty service, please contact FPI by mail at the address listed below. Please include a brief description of the problem and your address, email and telephone contact information. A representative will contact you to make arrangements for an inspection and/or warranty service.

Canadian Warrantor:**FPI Fireplace Products International Ltd.**

6988 Venture St.  
Delta, British Columbia  
Canada, V4G 1H4

U.S. Warrantor:**Fireplace Products US, Inc.**

PO Box 2189 PMB 125  
Blaine, WA  
United States, 98231

Or contact the Regency Customer Care Centre at 1-800-442-7432 (phone) / 604-946-4349 (fax)  
/customerservice@regency-fire.com (e-mail)

**Product Registration and Customer Support:**

Thank you for choosing a Regency Fireplace. Regency strives to be a world leader in the design, manufacture, and marketing of hearth products. To provide the best support for your product, we request that you complete a product registration form at <http://www.regency-fire.com/Customer-Care/Warranty-Registration.aspx> within **ninety (90)** days of purchase.

# Warranty Registration Card



**Product Registration and Customer Support:**

Thank you for choosing a Regency Fireplace. Regency strives to be a world leader in the design, manufacture, and marketing of hearth products. To provide the best support for your product, we request that you complete a product registration form found on our Web Site under Customer Care within ninety (90) days of purchase.

For purchases made in **CANADA or the UNITED STATES:**

<http://www.regency-fire.com/Customer-Care/Warranty-Registration.aspx>

For purchases made in AUSTRALIA:

<http://www.regency-fire.com.au/Customer-Care/Warranty-Registration.aspx>

You may also complete the warranty registration form below to register your Regency Fireplace Product and mail and/or fax it back to us, and we will register the warranty for you. It is important you provide us with all the information below in order for us to serve you better.

**Warranty Registration Form (or Register online immediately at the above Web Site):**

<b>Warranty Details</b>	
Serial Number (required):	
Purchase Date (required) (mm/dd/yyyy):	
<b>Product Details</b>	
Product Model (required):	
<b>Dealer Details</b>	
Dealer Name (required):	
Dealer Address:	
Dealer Phone #:	
Installer:	
Date Installed (mm/dd/yyyy):	
<b>Your Contact Details (required)</b>	
Name:	
Address:	
Phone:	
Email:	

For purchases made in CANADA:

**FPI Fireplace Products International Ltd.**  
6988 Venture St.  
Delta, British Columbia  
Canada, V4G 1H4

Phone: 604-946-5155  
Fax: 1-866-393-2806

For purchases made in the UNITED STATES:

**Fireplace Products US, Inc.**  
PO Box 2189 PMB 125  
Blaine, WA  
United States, 98231

Phone: 604-946-5155  
Fax: 1-866-393-2806

For purchases made in AUSTRALIA:

**Fireplace Products Australia Pty Ltd**  
99 Colemans Road  
Dandenong South, Vic.  
Australia, 3175

Phone: +61 3 9799 7277  
Fax: +61 3 9799 7822

For fireplace care and tips and answers to most common questions please visit our Customer Care section on our Web Site. Please feel free to contact your selling dealer if you have any questions about your Regency product.



**PRODUCT LIFE CYCLE:**

By recycling your used appliances, you divert waste from your local landfills and help the environment. You also reduce the need for raw materials to manufacture new products. Contact your local municipality for appliance recycling services, local recycling programs, or appliance removal services to ensure your Regency appliance components, and packaging are properly recycled.





***Installer: Please complete the following information***

**Dealer Name & Address:** \_\_\_\_\_  
\_\_\_\_\_

**Installer:** \_\_\_\_\_

**Phone #:** \_\_\_\_\_

**Date Installed:** \_\_\_\_\_

**Serial #:** \_\_\_\_\_