



Pro Series Wood Fireplace Insert

Owners & Installation Manual



French Manual: <https://bit.ly/3vaoKti>
Manuel en Français : <https://bit.ly/3vaoKti>

www.regency-fire.com

MODEL: CI2700/HI500



Installer: Please complete the details on the back cover and leave this manual with the homeowner.
Homeowner: Please keep these instructions for future reference.

Thank-you for purchasing a **REGENCY FIREPLACE PRODUCT**.

The pride of workmanship that goes into each of our products will give you years of trouble-free enjoyment. Should you have any questions about your product that are not covered in this manual, please contact the **REGENCY DEALER** in your area. Keep those **REGENCY FIRES** burning.

"This wood heater has a manufacturer set minimum low burn rate that must not be altered. It is against federal regulations to alter this setting or otherwise operate this wood heater in a manner inconsistent with operating instructions in this manual." Failure to follow the manual details can lead to smoke and CO emissions spilling into the home. It is recommended to have monitors in areas that are expected to generate CO such as heater fuelling areas.

"U.S. ENVIRONMENTAL PROTECTION AGENCY Certified to comply with 2020 particulate emission standards using cordwood." Model Regency CI2700 and HI500 – 1.3g/hr."

SAFETY NOTE: If this wood stove is not properly installed, a house fire may result. For your safety, follow the installation instructions, contact local building, fire officials, or authority having jurisdiction about restrictions and installation inspection requirements in your area.

The following statements are required by the Environmental Protection Agency:

"This manual describes the installation and operation of the Regency CI2700 and HI500 catalytic equipped wood heater. This heater meets the 2020 U.S. Environmental Protection Agency's crib wood emission limits for wood heaters. Under specific test conditions this heater has been shown to deliver heat at rates ranging from 8,292 BTU/hr to 29,511 BTU/hr." Efficiency is determined using the B415 method resulting in lower and higher heat values. This heater generates the best efficiency when operated using well-seasoned wood and installed in the main living areas where the majority of the chimney is within the building envelope and fully lined."

"This wood heater contains a catalytic combustor, which needs periodic inspection and replacement for proper operation. It is against federal regulations to operate this wood heater in a manner inconsistent with operating instructions in this manual, or if the catalytic element is deactivated or removed."

CAUTION: BURN UNTREATED WOOD ONLY. OTHER MATERIALS SUCH AS WOOD PRESERVATIVES, METAL FOILS, COAL, PLASTIC, GARBAGE, SULPHUR OR OIL MAY DAMAGE THE CATALYST

"This heater is designed to burn natural wood only. Higher efficiencies and lower emissions generally result when burning air dried seasoned hardwoods, as compared to softwoods or to green or freshly cut hardwoods."

DO NOT BURN:

- Treated wood
- Coal
- Garbage
- Cardboard
- Solvents
- Colored Paper
- Trash
- Lawn clippings or yard waste
- Materials containing rubber including tires
- Materials containing plastic
- Waste petroleum products, paints or paint thinners or asphalt products
- Materials containing asbestos
- Construction or demolition debris
- Railroad ties
- Manure or animal remains
- Saltwater driftwood or other previously salt water saturated materials
- Unseasoned wood
- Paper products, cardboard, plywood or particle board. The prohibition against burning these materials does not prohibit the use of fire starters made from paper, cardboard, saw dust, wax and similar substances for the purpose of starting a fire in a wood heater

Burning these materials may result in release of toxic fumes or render the heater ineffective and cause smoke.

The authority having jurisdiction (such as Municipal Building Department, Fire Department, Fire Prevention Bureau, etc.) should be consulted before installation to determine the need to obtain a permit.

This unit must be connected to either a listed factory built chimney suitable for use with solid fuels and conforming to, UL1777, ULCS635 and ULCS640, or code approved masonry chimney with flue liner. CI2700/HI500 is tested and certified to UL-1482 (R2015), and ULC-S628 (R1997).

SAVE THESE INSTRUCTIONS



919-874

Copy of Safety Decal 4
 Location of the Safety Decal..... 4

Dimensions

Dimensions - Contemporary Faceplate 5
 Dimensions - Standard Cast Faceplate and Offset Flue Collar 6
 Dimensions - Low Profile Faceplate 7
 Dimensions - Standard Cast Faceplate 7
 Dimensions - Standard Backing Plate 8
 Dimensions - Oversized Backing Plate 8

Installation

Masonry and Factory Built Fireplace Clearances 9
 How To Determine If Alternate Floor Protection Materials Are Acceptable 9
 Wood Insert Specifications 9
 Installation Into A Masonry Fireplace 10
 Before Installing your Insert.....10
 Chimney Specifications10
 Installation into a Factory Built Fireplace11
 Altering the Fireplace.....11
 Draft11
 Installing Your Insert12
 Digital Catalytic Combustor Monitor14
 Levelling Bolts15
 Optional Cast Grill Installation16
 Firebrick Assembly.....16
 Optional Backing Plate Installation.....17
 Contemporary Faceplate Installation18
 Low Profile Faceplate Installation.....20
 Cast Faceplate Installation22
 Oversize Cast Faceplate Installation24
 Optional Fan/Blower Installation26
 Removable Door Handle28
 Bypass Handle28

Operating Instructions

Seasoned Wood 29
 Operating Instructions 30
 Draft Control 30
 First Fire 30
 Ash Disposal 31
 Fan Operation 31
 Creosote..... 31
 Removal for Cleaning..... 31
 Ways to Prevent and Keep Unit Free of Creosote 31
 Wood Storage 31
 Safety Guidelines & Warnings..... 31
 Catalytic Combustor (Part # 106-534)..... 33
 Combustor Assembly Removal/Replacement 34
 Bypass Door Gasket Replacement 35

Maintenance

Door Gasket..... 36
 Glass Cleaning 36
 Glass Replacement 36
 Glass Removal..... 36
 Annual Maintenance 37
 Secondary Air Tube Removal/Installation..... 38
 Door Catch Adjustment..... 38
 Cast Bypass Top Plate Removal/Installation 39
 Fan Operation Into Auto Mode 39
 Sweeping the Flue From the Top Down 40

Parts List

Main Assembly 41
 Brick Layout..... 43

Warranty

Warranty 44
 Catalytic Combustor Coverage Warranty..... 49

CAUTION: To avoid burns or wood splinters, when opening/closing the fuel door or adding wood to the fire, You should always wear appropriate protective gloves to protect your hands from the heat being emitted from this fireplace.

4 | safety decal

SAFETY LABEL FOR CI2700

This is a copy of the label that accompanies your **Regency Insert**. We have printed a copy of the contents here for your review.

NOTE: Regency units are constantly being improved. Check the label on the unit and if there is a difference, the label on the unit is the correct one.



Report #0219WN0175

LISTED FACTORY BUILT FIREPLACE INSERT
CONSTRUITS EN USINE CHEMINÉE INSERT
CERTIFIED FOR USE IN CANADA AND U.S.A.
CERTIFIÉE POUR: CANADA AND U.S.A.
MODEL NO./LE: CI2700/HI500
TESTED TO: UL-1482 (R2015), and ULC-S628 (R1997)



DO NOT REMOVE THIS LABEL
NE PAS ENLEVER CETTE ETIQUETTE

U.S. ENVIRONMENTAL PROTECTION AGENCY CERTIFIED TO COMPLY WITH 2020 PARTICULATE EMISSION STANDARDS USING CORD WOOD. * TESTED TO ASTM E3083. MODEL REGENCY CI2700/HI500 - 1.3G /HR. THIS WOOD HEATER NEEDS PERIODIC INSPECTION AND REPAIR FOR PROPER OPERATION. CONSULT THE OWNER'S MANUAL FOR FURTHER INFORMATION. IT IS AGAINST FEDERAL REGULATIONS TO OPERATE THIS WOOD HEATER IN A MANNER INCONSISTENT WITH THE OPERATING INSTRUCTIONS IN THE OWNER'S MANUAL. CERTIFIÉ CONFORME AUX NORMES 2020 DU U.S. ENVIRONMENTAL PROTECTION AGENCY EN MATIÈRE D'ÉMISSION DE PARTICULES DE BOIS AVEC DU BOIS DE CORDE*. APPROUVÉ ASTM E3083. MODÈLE REGENCY CI2700/HI500 - 1,3 G/H. CET APPAREIL DE CHAUFFAGE AU BOIS DOIT ÊTRE INSPECTÉ PÉRIODIQUEMENT ET RÉPARÉ POUR FONCTIONNER CORRECTEMENT. CONSULTEZ LE MANUEL D'INSTALLATION POUR PLUS D'INFORMATION. LA RÉGLEMENTATION FÉDÉRALE INTERDIT DE FAIRE FONCTIONNER UN TEL APPAREIL SI LES CONSIGNES D'UTILISATION CONTENUES DANS LE PRÉSENT MANUEL NE SONT PAS RESPECTÉES.

INSTALL AND USE ONLY IN ACCORDANCE WITH THE MANUFACTURER'S INSTALLATION AND OPERATING INSTRUCTIONS. INSTALL AND USE ONLY IN MASONRY FIREPLACE OR FACTORY BUILT FIREPLACE. CONTACT LOCAL BUILDING OR FIRE OFFICIALS ABOUT RESTRICTIONS AND INSTALLATION INSPECTION IN YOUR AREA. INSTALLER ET UTILISER SELON LES INSTRUCTIONS DU FABRICANT. INSTALLER ET UTILISER DANS UN FOYER DE MAÇONNERIE OU PRÉFABRIQUÉ. APPELÉZ VOTRE INSPECTEUR DE BÂTIMENT OU LE DÉPARTEMENT D'INCENDIE LOCAL POUR LES CODES LOCAUX ET POUR INSPECTÉE VOTRE INSTALLATION ET FOYER.

MINIMUM CLEARANCES TO COMBUSTIBLE MATERIALS (MEASURED FROM TOP/SIDE DOOR)
UN MINIMUM DE DÉGAGEMENT DE MATÉRIAUX COMBUSTIBLES (MESURÉE À PARTIR DU HAUT/PORTE LATÉRALE)

<p>ADJACENT SIDEWALL / LATÉRAL ADJACENT A) 12-3/16 in / 310 mm MANTLE / MANTEAU B) 21-5/8 in / 549 mm TOP FACING/FACE SUPÉRIEUR C) 14 in / 356 mm SIDE FACING / FACE CÔTÉ D) 7-3/8 in / 187 mm</p>	<p>INSTALL ONLY ON A NON-COMBUSTIBLE HEARTH COMBUSTIBLE FLOOR MUST BE PROTECTED BY NON-COMBUSTIBLE MATERIAL EXTENDING (E) 18 IN / 457 MM TO FRONT AND (G) 8 IN / 205 MM TO SIDES FROM FUEL DOOR. IN CANADA, SIDE HEARTH PROTECTION TO BE MEASURED FROM SIDE OF UNIT. FLOOR PROTECTION NEEDS TO BE WITH R VALLÉE = 2.13 INSTALLER SUR UN ÂTRE DE MATÉRIAU NON COMBUSTIBLE SURÉLEVÉ COMBUSTIBLE ADJACENT. LE PLANCHER COMBUSTIBLE DOIT ÊTRE PROTÉGÉ PAR LE MATÉRIAU NON COMBUSTIBLE QUI ÉTENDRE (E) 18 po / 457 MM À L'AVANT ET (G) 8 po / 205 MM SUR LES CÔTÉS DE LA PORTE DE CARBURANT. AU CANADA, LA PROTECTION DE FOYER DE CÔTÉ ÊTRE MESURÉE À PARTIR CÔTÉ DE L'APPAREIL. PROTECTION DE PLANCHER BESOIN D'ÊTRE AVEC LA VALEUR R = 2.13</p>
---	--



CAUTION

HOT WHILE IN OPERATION DO NOT TOUCH. KEEP CHILDREN, CLOTHING AND FURNITURE AWAY. CONTACT MAY CAUSE SKIN BURNS. READ NAMEPLATE AND INSTRUCTIONS.

AVERTISSEMENT

CHAUD PENDANT LE FONCTIONNEMENT. NE PAS TOUCHER. GARDER LES ENFANTS, LES VÊTEMENTS ET LES MEUBLES À L'ÉCART. LE CONTACT AVEC LA PLaque PEUT OCCASIONNER DES BRÛLURES. LIRE LA PLAQUE SIGNALÉTIQUE ET LES INSTRUCTIONS.

COMPONENTS REQUIRED FOR INSTALLATION: 6" (152mm) STAINLESS STEEL LINER - LISTED TO: UL1777, ULC6835 OR ULC6840. OPTIONAL COMPONENT: FAN (PART# 106-917), ELECTRICAL RATING: VOLTS 115, 60 HZ, 0.6 AMPS, CONTEMPORARY FACEPLATE, CONTOUR FACEPLATE, CAST FACEPLATE, OFFSET FLUE COLLAR, OR BACKER PLATE.
DANGER: RISK OF ELECTRIC SHOCK. DISCONNECT POWER BEFORE SERVICING UNIT. DO NOT ROUTE POWER CORD UNDER OR IN FRONT OF APPLIANCE. DO NOT CONNECT THIS UNIT TO A CHIMNEY FLUE SERVICING ANOTHER APPLIANCE. DO NOT REMOVE BRICKS OR MORTAR IN MASONRY FIREPLACE. FOR USE WITH SOLID WOOD FUEL ONLY. DO NOT USE GRATE OR ELEVATE FIRE. BUILD WOOD FIRE DIRECTLY ON HEARTH. RISK OF SMOKE AND FLAME SPILLAGE, OPERATE ONLY WITH DOORS FULLY CLOSED. OPEN FEED DOOR TO FEED FIRE ONLY. REPLACE GLASS ONLY WITH CERAMIC GLASS (5MM). INSPECT AND CLEAN CHIMNEY FREQUENTLY. UNDER CERTAIN CONDITIONS OF USE CREOSOTE BUILDUP MAY OCCUR RAPIDLY. DO NOT OVERFIRE. IF INSERT GLOWS, YOU ARE OVER-FIRING. CAUTION: THE COMBUSTOR (PART #106-534) IS FRAGILE, HANDLE CAREFULLY. CAUTION: BURNING OF METAL FOILS, COAL, PLASTIC, GARBAGE, SULPHUR AND DIESEL OIL WILL RENDER THE CATALYST IN THE COMBUSTOR INACTIVE. THE PERFORMANCE OF THE CATALYTIC DEVICE OR ITS DURABILITY HAS NOT BEEN EVALUATED AS PART OF THE CERTIFICATION. CAUTION: HOT PARTS-DO NOT OPERATE WITH DOOR REMOVED.
PIÈCES NÉCESSAIRES POUR INSTALLATION: 6" (152MM) CONDUITS EN ACIER INOXYDABLE. HOMOLOGUÉ SELON: UL1777, ULC6835 OU ULC6840. COMPOSANT FACULTATIF: VENTILATEUR (PIÈCE 106-917); CARACTÉRISTIQUES ÉLECTRIQUES ASSIGNÉES: 115 V, 60 HZ, 0.6 A; FAÇADE CONTEMPORAINE, FAÇADE BISEAUTÉE, FAÇADE EN FONTE, BUSET DE CONDUIT DE CHEMINÉE COUDÉ OU PLAQUE DE FIXATION. ATTENTION: RISQUE DU CHOC ÉLECTRIQUE. AVANT DE L'ENTRETIEN, DÉBRANCHER L'APPAREIL. NE PLACEZ PAS LE CORDON D'ALIMENTATION EN FACE OU EN DESSOUS DE L'APPAREIL. NE PAS ENLEVER DE BRIQUES OU DE MORTIER D'UNE CHEMINÉE DE MAÇONNERIE. N'UTILISER QUE DU COMBUSTIBLE SOLIDE. REMPLACEZ LA VITRE SEULEMENT PAR DU VERRE EN NEOCERAM. NE PAS SURÉLÉVER LES BûCHES NI LES PLACER SUR DES GRILLES. LES DÉPOSER DIRECTEMENT SUR L'ÂTRE. RISQUE DE DÉGAGEMENT DE FUMÉE OU DE FLAMMES: TOUJOURS GARDER LES PORTES BIEN FERMÉES LORSQUE L'APPAREIL FONCTIONNE. OUVRIRE LA PORTE UNIQUEMENT POUR ALIMENTER LE FEU. INSPECTER ET NETTOYER FREQUENTEMENT LA CHEMINÉE. SELON LE TYPE D'USAGE, LE CRÉOSOTE PEUT S'ACCUMULER RAPIDEMENT.
NE PAS SURCHAUFFER. SI L'ENCASTRABLE SE MET À ROUGIR, IL S'AGIT D'UNE SURCHAUFFE.
AVERTISSEMENT: LE CATALYSEUR (PIÈCE 106-534) EST FRAGILE ET DOIT ÊTRE MANIPULÉ SOIGNEUSEMENT. LA COMBUSTION DE PAPIER D'ALUMINIUM, DE CHARBON, DE PLASTIQUE, DE DÉCHETS, DE SOUFRE OU D'ESSENCE DIESEL RENDRA LE CATALYSEUR INACTIF. NI LE RENDEMENT NI LA DURABILITÉ DU CATALYSEUR N'ONT ÉTÉ ÉVALUÉS DANS LE CADRE DU PROCESSUS D'HOMOLOGATION. REMARQUE: TEMPÉRATURES ÉLEVÉES. NE JAMAIS FAIRE FONCTIONNER L'APPAREIL SI LA PORTE VITRÉE N'EST PAS BIEN EN PLACE.

Manufactured By: **FIREPLACE PRODUCTS INTERNATIONAL LTD.**
6988 VENTURE ST., DELTA, BC V4G 1H4

Serial No./ No de série
516

DATE OF MANUFACTURE

Jan	Feb	Mar	Apr	May	June	July	Aug	Sept	Oct	Nov	Dec
<input type="checkbox"/>	<input type="checkbox"/>	<input type="checkbox"/>	<input type="checkbox"/>	<input type="checkbox"/>	<input type="checkbox"/>	<input type="checkbox"/>	<input type="checkbox"/>	<input type="checkbox"/>	<input type="checkbox"/>	<input type="checkbox"/>	<input type="checkbox"/>

2021 2022 2023 2024 2025

(Duplicate Serial #) 516

LOCATION OF THE SAFETY LABEL

1. If low profile faceplate is installed would need to be removed to expose decal.
2. If Contemporary or cast faceplate is installed the bottom drawer would need to be opened up to expose decal
3. If fan assembly is installed would need to be removed to expose decal.

4 | CI2700/HI500 Wood Insert

DIMENSIONS - CONTEMPORARY FACEPLATE

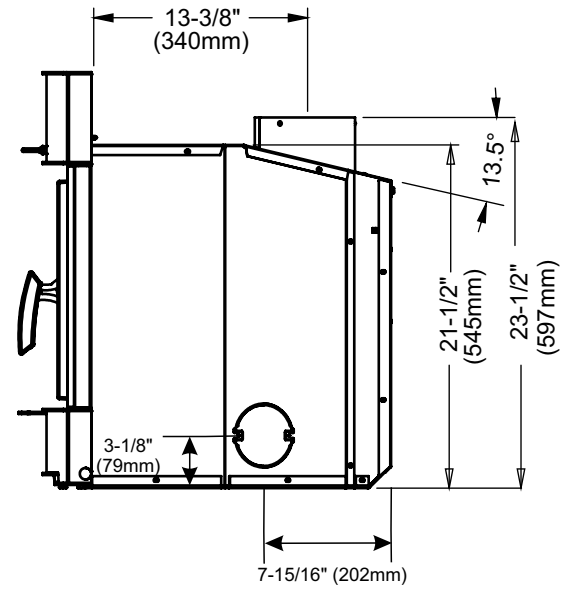
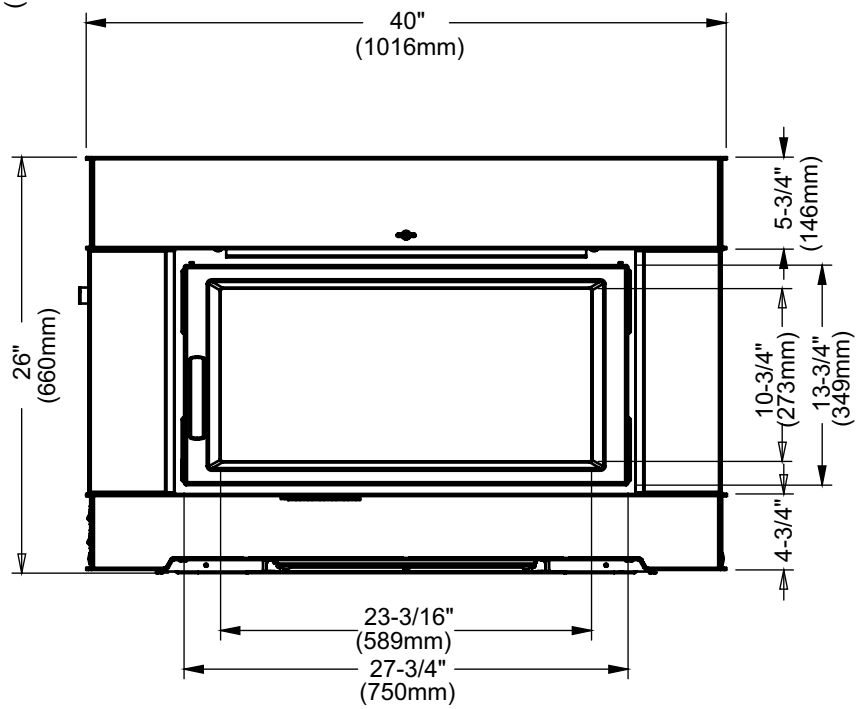
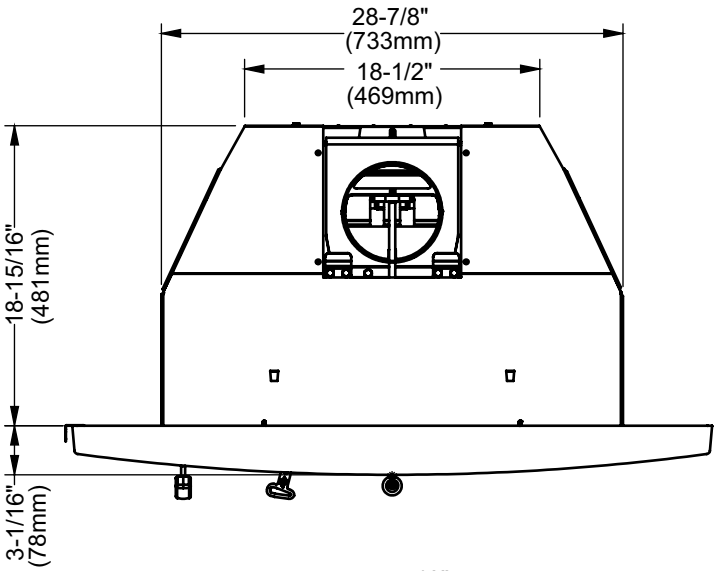

ALL PICTURES / DIAGRAMS SHOWN THROUGHOUT THIS MANUAL ARE FOR ILLUSTRATION PURPOSES ONLY. ACTUAL PRODUCT MAY VARY DUE TO PRODUCT ENHANCEMENTS.

6 | dimensions

DIMENSIONS - STANDARD CAST FACEPLATE AND OFFSET FLUE COLLAR

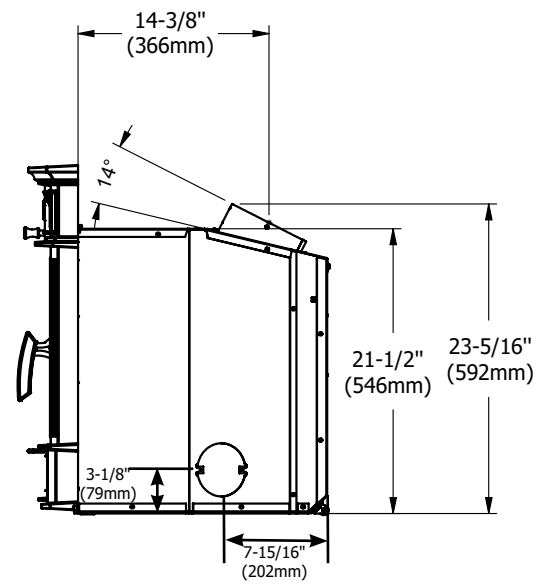
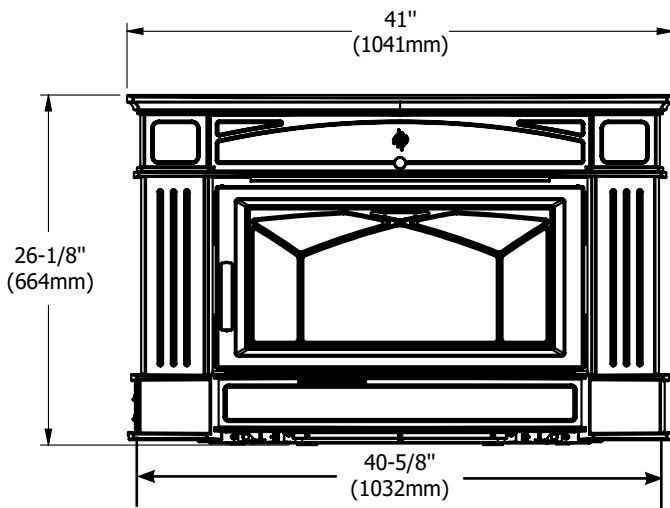
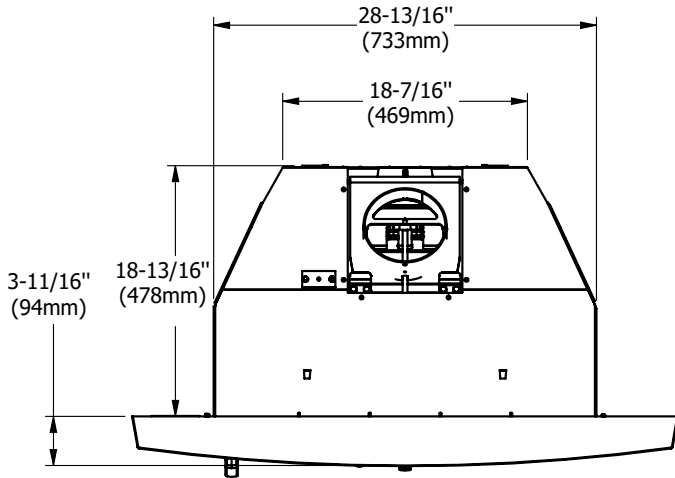

DIMENSIONS - LOW PROFILE FACEPLATE

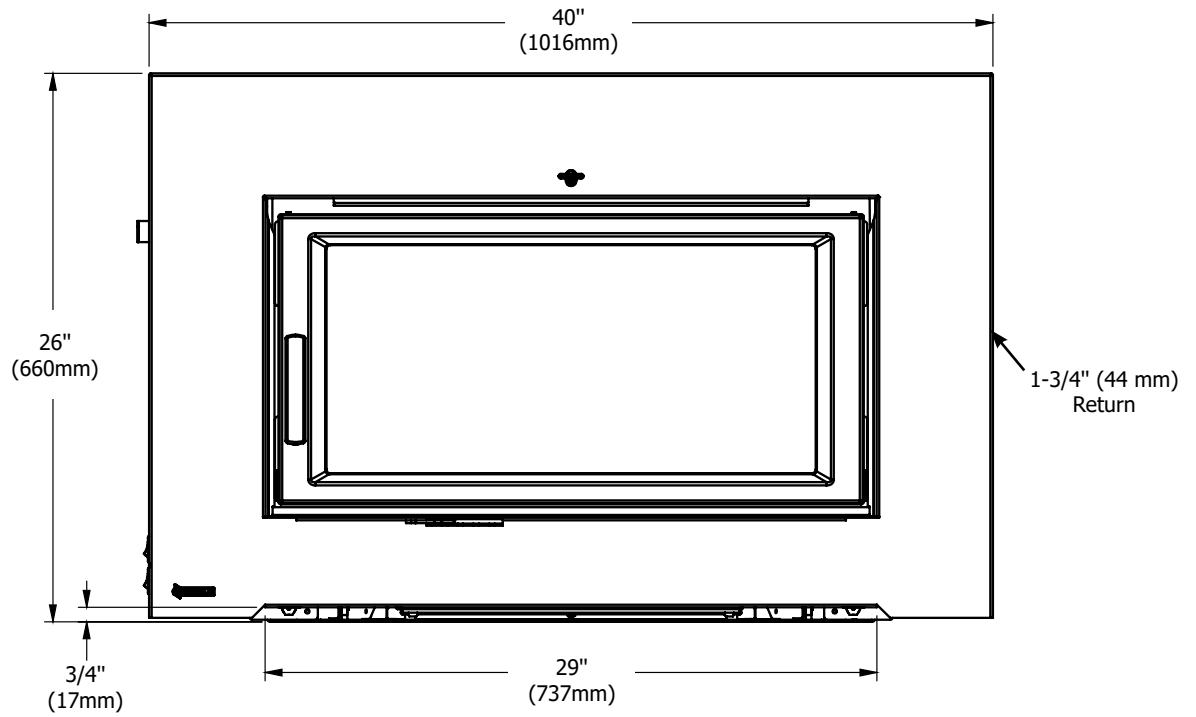

DIMENSIONS - STANDARD CAST FACEPLATE

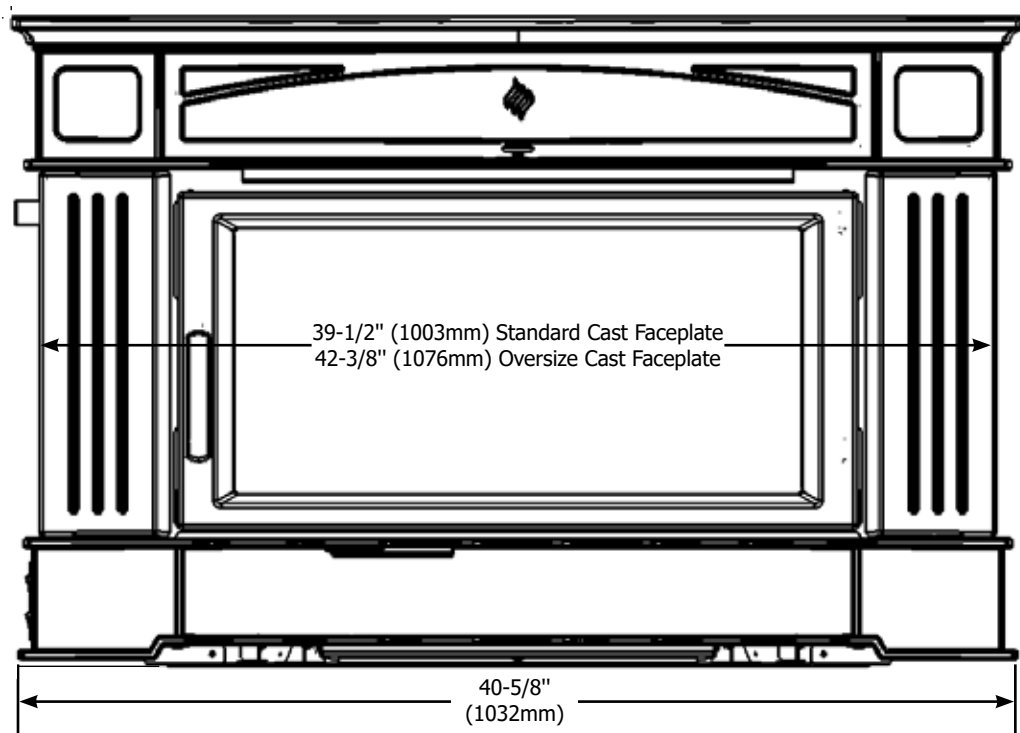

Standard Cast Faceplate shown above
Oversized Cast Faceplate Dimensions: 44" W x 31" H

8 | dimensions

DIMENSIONS - STANDARD BACKING PLATE

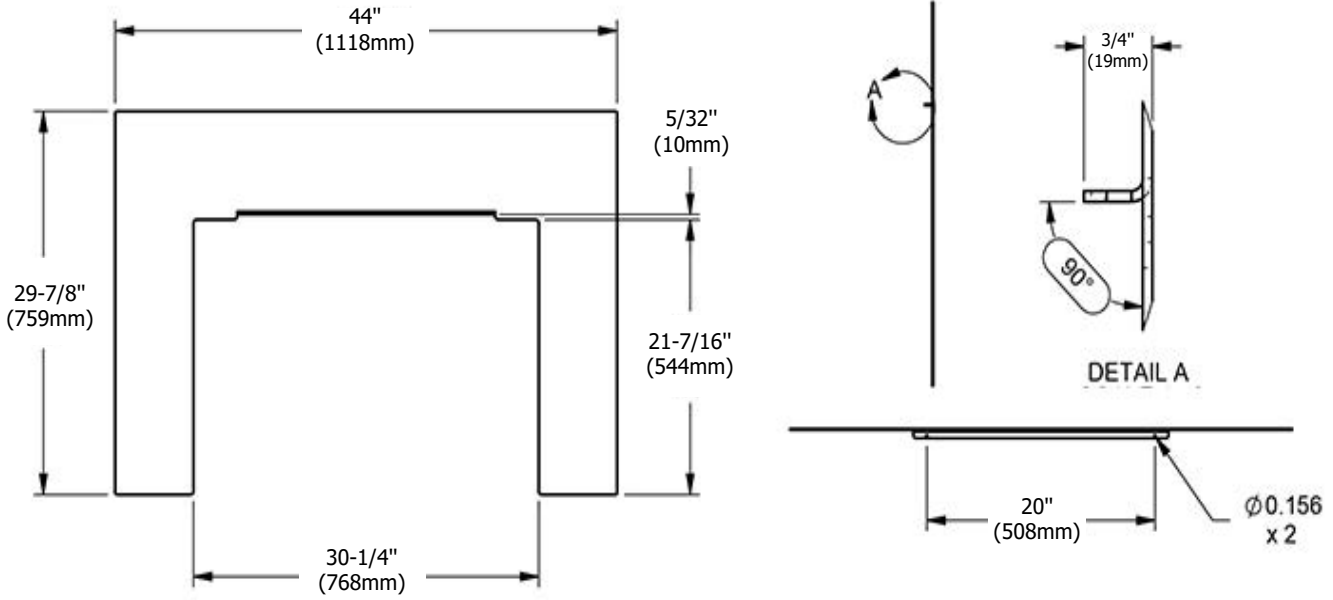

DIMENSIONS - OVERSIZED BACKING PLATE

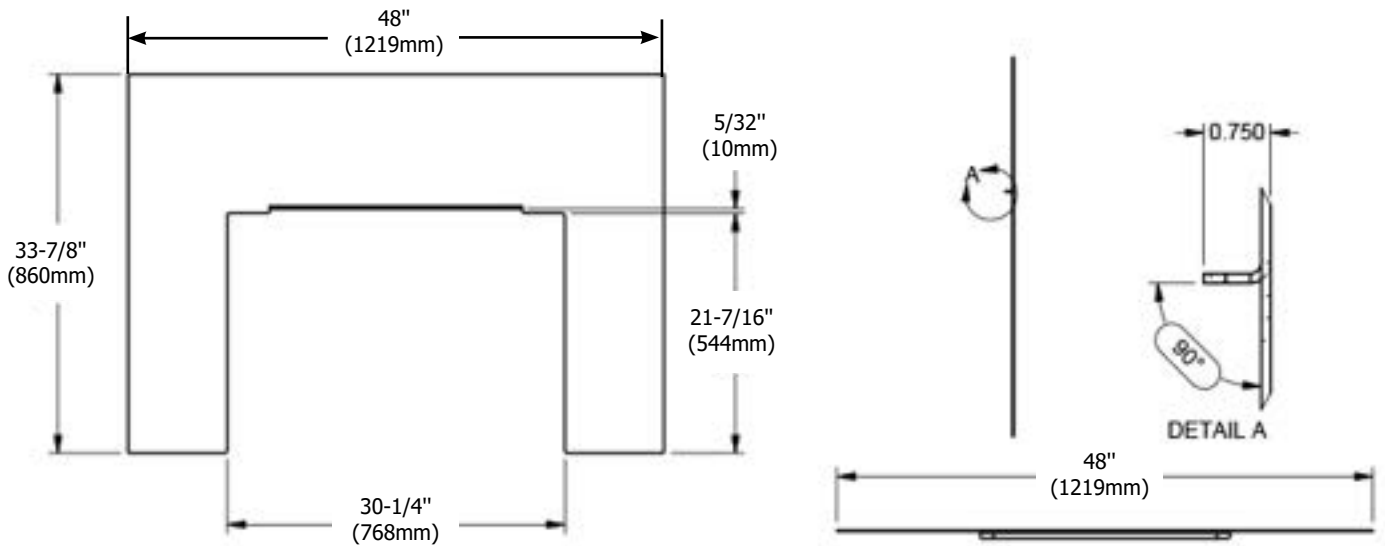

MASONRY AND FACTORY BUILT FIREPLACE CLEARANCES

The minimum required clearances to combustible materials when installed into a masonry or factory built fireplace are listed below.

Unit	Adjacent Side Wall (to Side of Door) A	Mantle ** (to Top of Door) B	Top Facing (to Top of Door) C	Side Facing (to Side of Door) D	Minimum Hearth Extension* E	Minimum Hearth Side Extension* F	To Top of Door G
CI2700/ HI500	12-3/16"	21-5/8"	14"	7-3/8"	US 16" Canada 18"	8"	19-1/4"
Measurements A,B,C,D are from top/side of door							

Side and Top facing is a maximum of 1.5" thick.

- * Side hearth extension for Canada measured from side of appliance.
- * Hearth extension to have minimum: R value of 2.13 or greater.
- ** A non-combustible mantel may be installed at a lower height if the framing is made of metal studs covered with a non-combustible board.
- ** Max. mantle depth is 10" (254mm).

Thermal floor protection is not required if the unit is raised 6.5" minimum (measured from the bottom of the stove). However, standard ember floor protection is required. It will need to be a non-combustible material that covers 16" (406 mm) in the US and 18" (450 mm) in Canada to the front of the unit and 8" (200 mm) to the sides.

All floor protection must be non-combustible (i.e., metals, brick, stone, mineral fiber boards, etc.) Any organic materials (i.e. plastics, wood paper products, etc.) are combustible and must not be used. The floor protection specified includes some form of thermal designation similar to R-value (thermal resistance) or k-factor (thermal conductivity). Floor protector listed to UL1618.

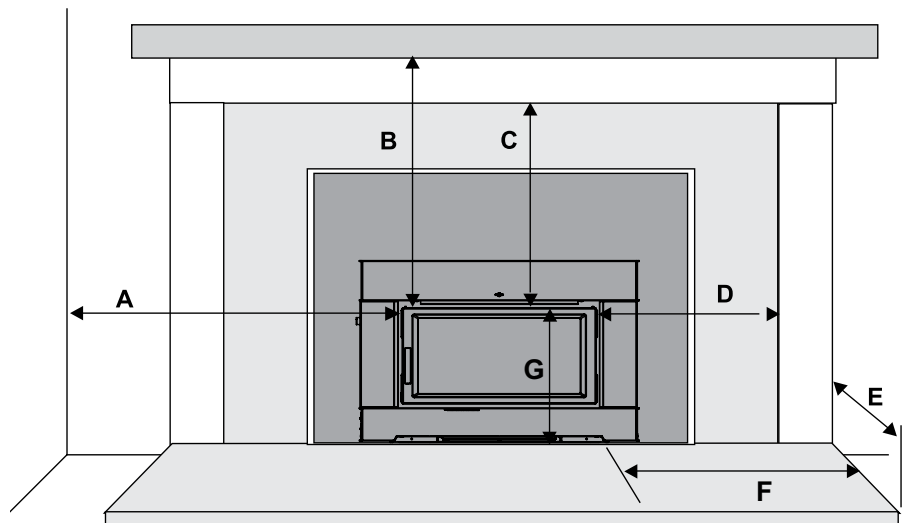

Clearance diagram for Installations

Minimum Hearth Extension for the front (E) and sides (F) are measured from the fuel door opening.

HOW TO DETERMINE IF ALTERNATE FLOOR PROTECTION MATERIALS ARE ACCEPTABLE

The specified floor protector should be 3/8" (18mm) thick material with a K - factor of 0.84.

The proposed alternative is 4" (100mm) brick with a C-factor of 1.25 over 1/8" (3mm) mineral board with a K-factor of 0.29.

Step (a):

Use formula above to convert specification to R-value.
 $R = 1/k \times T = 1/0.84 \times .75 = 0.893.$

Step (b):

Calculate R of proposed system.
 4" brick of C = 1.25, therefore
 $R_{brick} = 1/C = 1/1.25 = 0.80$
 1/8" mineral board of k = 0.29, therefore
 $R_{min.bd.} = 1/0.29 \times 0.125 = 0.431$
 Total R = $R_{brick} + R_{mineral\ board} = 0.8 + 0.431 = 1.231.$

Step (c):

Compare proposed system R of 1.231 to specified R of 0.893. Since proposed system R is greater than required, the system is acceptable.

DEFINITIONS

Thermal Conductance:

$$C = \frac{\text{Btu}}{(\text{hr})(\text{ft}^2)(\text{°F})} = \frac{W}{(\text{m}^2)(\text{K})}$$

Thermal Conductivity:

$$k = \frac{(\text{Btu})(\text{inch})}{(\text{hr})(\text{ft}^2)(\text{°F})} = \frac{W}{(\text{m})(\text{K})} = \frac{\text{Btu}}{(\text{hr})(\text{ft})(\text{°F})}$$

Thermal Resistance:

$$R = \frac{(\text{ft}^2)(\text{hr})(\text{°F})}{\text{Btu}} = \frac{(\text{m}^2)(\text{K})}{W}$$

WOOD INSERT SPECIFICATIONS

Your fireplace opening requires the following minimum sizes:

- Height:** 21-3/4" (552 mm)
- Width:** 29" (737 mm)
- Depth:** 19" (483 mm)

INSTALLATION INTO A MASONRY FIREPLACE

Regency Inserts are constructed with the highest quality materials and assembled under strict quality control procedures that insure years of trouble free and reliable performance.

It is important that you read this manual thoroughly and fully understand the safe installation and operating procedures. The more you understand the way your Regency Insert operates, the more enjoyment you will experience from knowing that your unit is operating at peak performance.

BEFORE INSTALLING YOUR INSERT

1. Please read this entire manual before you install and use your new wood insert. Failure to follow instructions may result in property damage, bodily injury or even death. Install and use only in accordance with manufacturer's installation and operating instructions.
 2. Check your local building codes - Building Inspection Department. You may require a permit before installing your insert. **Be aware that local codes and regulations may override some items in the manual.**
- WARNING: Careless installation is the major cause of safety hazard. Check all local building and safety codes before installation of unit.**
3. Notify your home insurance company that you plan to install a fireplace insert or hearth heater.
 4. Your fireplace insert is heavy and requires two or more people to move it safely. The insert can be badly damaged by mishandling.
 5. If your existing fireplace damper control will become inaccessible once you have installed your Regency Insert, you should either remove or secure it in the open position.
 6. Inspect your fireplace and chimney prior to installing your insert to determine that it is free from cracks, loose mortar or other signs of damage. If repairs are required, they should be completed before installing your insert. Do not remove bricks or mortar from your masonry fireplace.
 7. **Do not connect the insert to a chimney system servicing another appliance or an air distribution duct.**

When referencing installation or connection to masonry fireplaces or chimneys, the masonry construction must or shall be code complying.

CHIMNEY SPECIFICATIONS

Before installing, check and clean your chimney system thoroughly. If in doubt about its condition, seek professional advice. Your Regency Insert is designed for installation into a masonry fireplace that is constructed in accordance with the requirements of "The Standard for Chimneys, Fireplaces, Vents, and Solid Fuel Burning Appliance", N.F.P.A. 211, the National Building Code of Canada, or the applicable local code requirements.

The appliance, when installed, must be electrically grounded in accordance with local codes or, in the absence of local codes, with the National Electrical Code, ANSI/NFPA 70, or the Canadian Electrical code, CSA C22.1.

Regency Inserts are designed to use either a 5.5" (140mm) or 6" (152mm) flue.

In Canada this fireplace insert must be installed with a continuous chimney liner of 5.5" (140 mm) or 6" (152 mm) diameter extending from the fireplace insert to the top of the chimney. The chimney liner must conform to the Class 3 requirements of CAN/ULC-S635 or CAN/ULC-S640, Standard for Lining Systems for New Masonry Chimneys.

In the U.S.A., a 5.5 inch (140 mm) or 6 inch (152 mm) diameter, stainless steel, full height chimney liner that meets type HT (2100° F) requirements per UL 1777 must be installed. The full liner must be attached to the insert flue collar and to the top of the existing masonry chimney.

Draft is the force which moves air from the appliance up through the chimney. The amount of draft in your chimney depends on the length of the chimney, local geography, nearby obstructions and other factors. Too much draft may cause excessive temperatures in the appliance and may cause damage. An uncontrollable burn or excessive temperature indicates excessive draft. Inadequate draft may cause back puffing into the room and plugging of the chimney. Inadequate draft will cause the appliance to leak smoke into the room through appliance and chimney connector joints. Ensure the heater is installed in areas that are not too close to neighbors or in valleys that would cause unhealthy air quality or nuisance conditions.

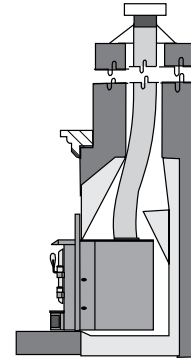

Note: On this appliance, there is a screw directly above the bypass rod located on the flue collar as shown below. This screw is located in its position to prevent the liner/adaptor from coming into contact with the bypass rod. Please do not remove. This must remain in place at all times.

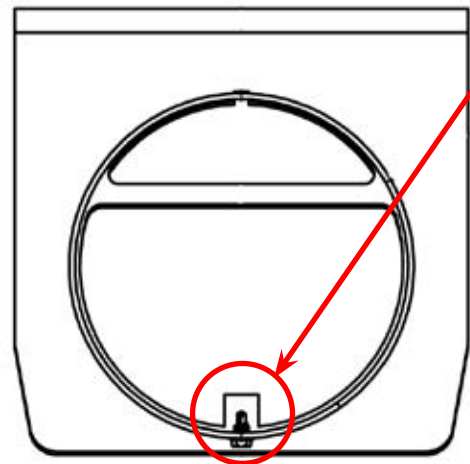

INSTALLATION INTO A FACTORY BUILT FIREPLACE

Regency inserts are constructed with the highest quality materials and assembled under strict quality control procedures that ensure years of trouble free and reliable performance.

It is important that you read this manual thoroughly and fully understand the installation and operating procedures. Failure to follow instructions may result in property damage, bodily injury or even death. The more you understand the way your Regency Insert operates, the more enjoyment you will experience from knowing that your unit is operating at peak performance.

Requirements for Installing Solid-fuel Inserts in Factory-built Fireplaces

1. A permit may be required for installations, final approval is contingent of the authority having local jurisdiction. Consult insurance carrier, local building, fire officials or authorities having jurisdiction about restrictions, installation inspection, and permits.
2. Inspect the existing fireplace and chimney for any damage or flaws such as burnouts, metal or refractory warping.
3. Inspection to a minimum of NFPA 211 Level II is recommended. All repairs must be made prior to installing an insert. The fireplace must be structurally sound and be able to support the weight of the solid-fuel insert.
4. The factory-built chimney must be listed per UL 127 or ULC 610-M87 for all installations. Install thermal protection as per this appliance listing requirements.
5. A full height 5.5 inch (140 mm) or 6 inch (152 mm) diameter stainless steel full height listed chimney liner must be installed meeting type HT (2100°F) requirements per UL 1777 (USA) or ULC S635 with "0" clearance to masonry (Canada). The full liner must be attached to the insert flue collar and to the top of the existing chimney.
6. The flue liner top support attachment must not reduce the air flow for the existing air-cooled chimney system. Reinstall original factory-built chimney cap only.
7. To prevent room air passage to the chimney cavity of the fireplace, seal either the damper area around the chimney liner or the insert surround. Circulating air chamber (i.e. in a steel fireplace liner or metal hearth circulatory) may not be blocked. The air flow within and around the fireplace shall not be altered, blocked by the installation of the insert (i.e. not louvers or cooling air inlet or outlet ports may be blocked by the insert or the insert surround).
8. Means must be provided for removal of the insert to clean the chimney flue.
9. Inserts that project in front of the fireplace must be supplied with appropriate supporting means.
10. Installer must mechanically attach the supplied label to the inside of the firebox of the fireplace into which the insert is installed.

⚠ WARNING

Fire Risk.
When lining air-cooled factory-built chimneys:

- Run chimney liner approved to **UL 1777 Type HT requirements (2100°F)**
- Reinstall original factory-built chimney cap **ONLY**
- **DO NOT** block cooling air openings in chimney
- Blocking cooling air will overheat the chimney

ALTERING THE FIREPLACE

The following modifications of factory-built fireplaces are permissible:

<i>The following parts may be removed:</i>	
Damper	Smoke Shelf or Baffle
Ember Catches	Fire Grate
Viewing Screen/Curtain	Doors

- The fireplace must be altered. Cutting any sheet metal parts of the fireplace in which the fireplace insert is to be installed is prohibited, except that the damper may be removed to accommodate a direct-connect starter pipe or chimney liner.
- External trim pieces which do not affect the operation of the fireplace may be removed providing they can be stored on or within the fireplace for reassembly if the insert is removed.
- The permanent metal warning label provided in the component pack must be attached to the back of the fireplace, with screws or nails, stating that the fireplace may have been altered to accommodate the insert, and must be returned to original condition for use as a conventional fireplace.
- If the hearth extension is lower than the fireplace opening, the portion of the insert extending onto the hearth must be supported.
- Manufacturer designed adjustable support kit can be ordered from your dealer.
- Final approval of this installation type is contingent upon the authority having jurisdiction.

WARNING: This fireplace may have been altered to accommodate an insert. It must be returned to its original condition before use as a solid fuel burning fireplace.

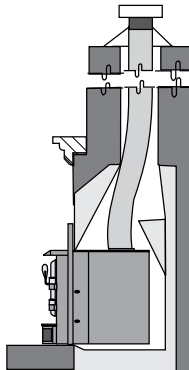

1. When installed in a factory built fireplace, a full stainless steel rigid or flexible flue liner is mandatory, for both safety and performance purposes. When a flue or liner is in use, the insert is able to breathe better by allowing a greater draft to be created. The greater draft can decrease problems such as, difficult start-ups, smoking out the door, and dirty glass.
2. In order to position the flue liner, the existing rain cap must be removed from your chimney system. In most cases the flue damper should also be removed to allow passage of the liner.
3. In most cases opening the existing spark screens fully should give enough room for the insert installation. If it does not, remove and store.
4. If the floor of your fireplace is below the level of the fireplace opening, adjust the insert's levelling bolts to accommodate the difference. When additional shiming is required, use non-combustible masonry or steel shims.
5. Measure approximately the alignment of the flue liner with the position of the smoke outlet hole on the insert to check for possible offset. If an offset is required, use the appropriate offset adaptor in your installation.

DRAFT

Draft is the force which moves air from the appliance up through the chimney. The amount of draft in your chimney depends on the length of the chimney, local geography, nearby obstructions and other factors. Too much draft may cause excessive temperatures in the appliance and may cause damage. An uncontrollable burn or excessive temperature indicates excessive draft. Inadequate draft may cause back puffing into the room and plugging of the chimney. Inadequate draft will cause the appliance to leak smoke into the room through appliance and chimney connector joints. Ensure the heater is installed in areas that are not too close to neighbors or in valleys that would cause unhealthy air quality or nuisance conditions.

INSTALLING YOUR INSERT

Your insert is very heavy and will require two or three people to move it into position. The insert can be made lighter by removing the cast iron door by opening it and lifting it off its hinges. Be sure to protect your hearth extension with a heavy blanket or carpet scrap during the installation. Evaluate your minimum cavity opening. If the cavity height lends itself to conduct the install without removing the flue collar, then just slide the unit into place and position the liner within the flue collar and secure.

If the cavity dictates the flue collar needs to be removed or the optional offset flue adaptor is required, please follow the steps below.

1. Remove door, manual package, and bricks - see instructions in manual.
2. Remove bypass rod - turn counter clockwise.

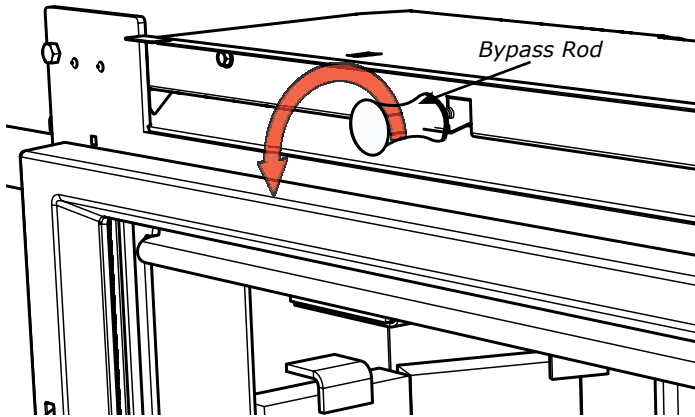

3. The bypass rod was threaded through a "fork" - access fork through the flue and remove by bringing it through the front of the unit.

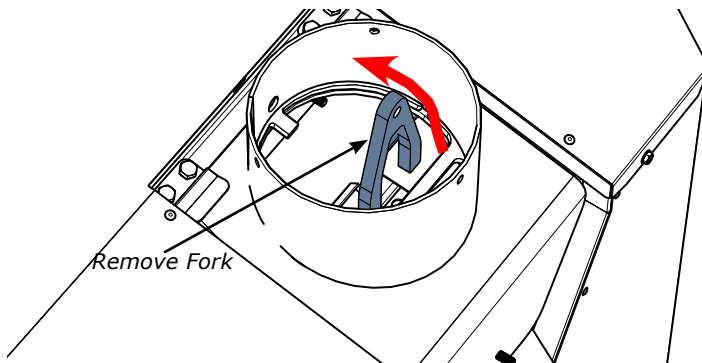

4. From inside the firebox - remove 7/16" bolt at back of firebox to remove the flue collar.

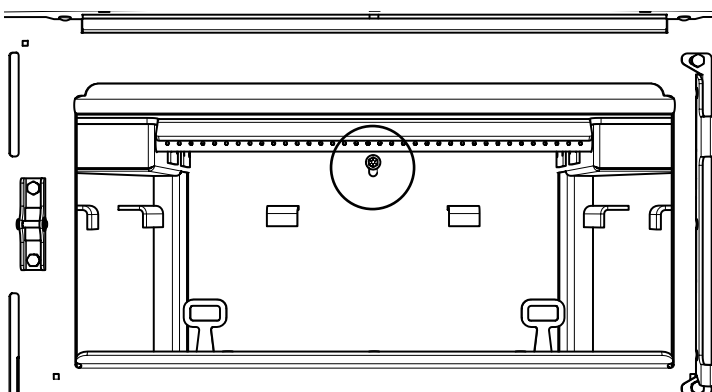

5. Install chimney liner, attach connector from flex kit with band and screws (ensure tabs on connector are positioned so they won't get in the way of the bypass rod - or remove them) attach flue collar with 2 or more screws, to the liner within fireplace cavity. Ensure to position at the proper height and angle to be able to attach the unit.

6. Before sliding the unit into place and attaching the collar - the following parts must be removed to allow access and a positive connection.

- a) Primary Air Shield
- b) Combustor Flame Shield
- c) Combustor
- d) Upper Shield - accessed through combustor opening
- e) Bottom Shield

7. Slide unit into position- ensure to centre with flue collar.

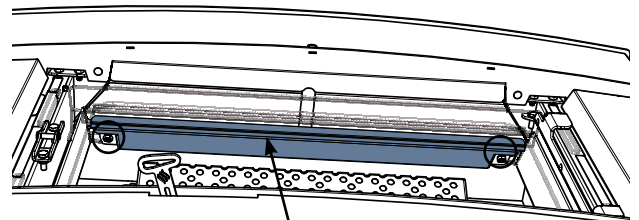

A- Primary Air Shield - loosen 2 x 7/16" bolts - slide forward to remove.

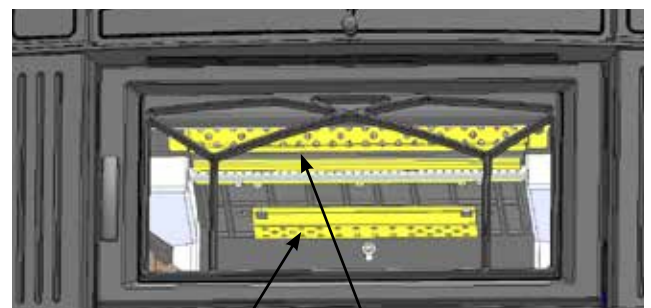

B- Combustor Flame Shield - loosen 2 x 7/16" bolts to remove.
E- Bottom Shield

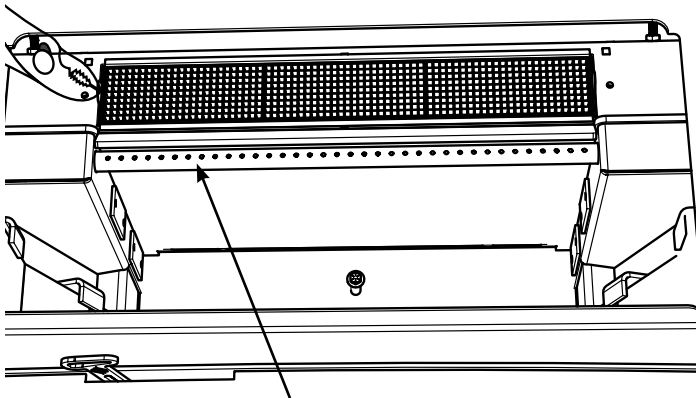

C- Combustor- remove with pliers
Tilt down and forward to ease removal.

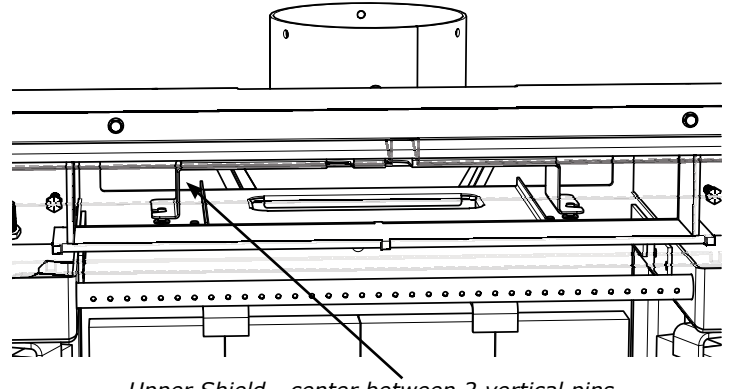

Upper Shield - center between 2 vertical pins

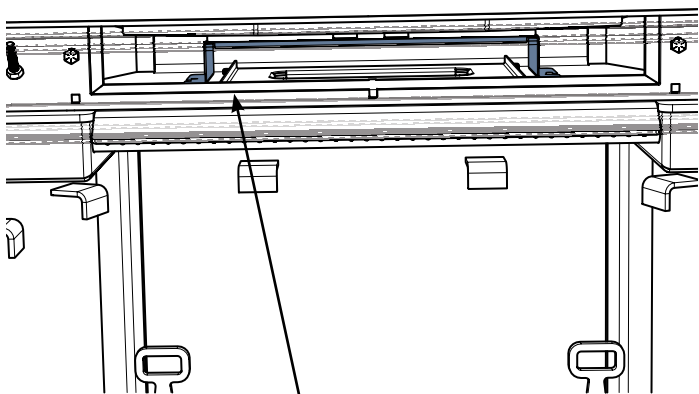

D- Upper Shield - slide forward and lift up to remove.

8. From inside the unit - grab the collar by accessing through the bypass opening. Pull the collar down and forward - use hook tool (provided with the unit) to assist removal. Secure with 7/16" bolt (removed in Step 4) while pulling collar down - to ensure positive connection. Ensure bolt is tightly secured and centred.
9. Reinstall the upper shield removed in Step 6e. Ensure upper shield is centered in between 2 (two) vertical pins from front to back. When positioning the upper shield locate the vertical pins by feel. When the shield parts are in place - slide to the back.
10. Reinstall "Fork" (removed in Step 4) on the bypass plate. **Ensure the letter "F" stamped into the Fork is facing towards the front of the unit.** Access through the combustor opening from inside the firebox to reinstall. Bypass plate may need centering before proceeding to next step.

11. Reinstall bypass rod through flue collar and into "Fork". Ensure bypass rod is screwed in tightly. Test bypass rod to ensure positive connection and review bypass opening.
12. Reinstall Combustor/Flame Combustor Shield / Primary Air Shield /Liner Shield.
13. Reinstall brick liners and door - (see detailed instructions in manual).
14. Center unit and install faceplate (see instructions in manual).
15. Install bypass knob onto bypass rod.



E- Upper Shield - orientation for reinstall

DIGITAL CATALYTIC COMBUSTOR MONITOR

The CI2700/HI500 is equipped with a provision to accept a catalytic temperature monitoring device. Please follow instructions below for the installation of the probe. Follow the user instructions of the catalytic monitoring device for product set up and details.

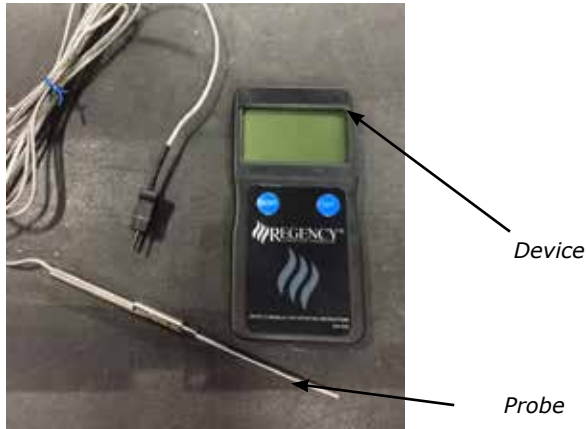

1. Remove two (2) bolts from the top of the unit to remove plate as shown below.

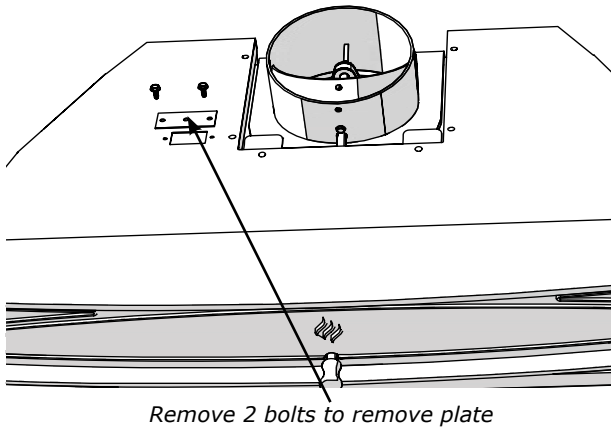

2. Locate the 7/16" bolt below the metal and remove.

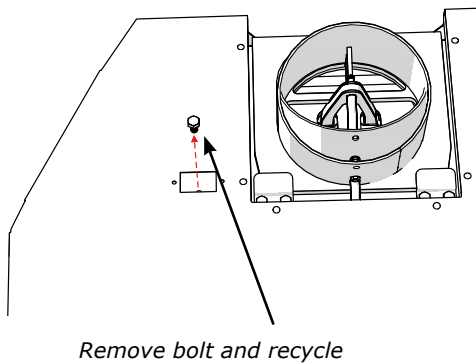

3. Reinstall the plate removed in Step 1 and insert the temperature probe through the plate and into the hole created by removing the bolt in Step 2.

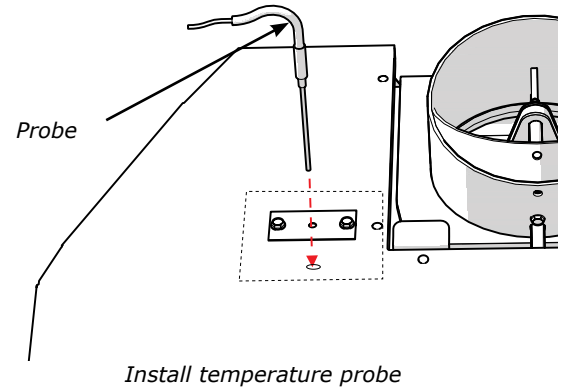

4. Complete the installation of the CI2700/HI500. Ensure temperature probe wire is routed behind the faceplate and to the left side of the unit. Plug in the monitoring device.

5. Monitoring device can be attached to the unit (with supplied velcro) on the hanger or the hearth beside the fireplace.



Important: The catalytic monitor probe which is supplied with this appliance must be installed prior to sliding the unit into final position in the masonry or factory built fireplace.

LEVELLING BOLTS

1. Use a 9/16" wrench to adjust the front leveling bolts located on the right and the left side of the firebox.

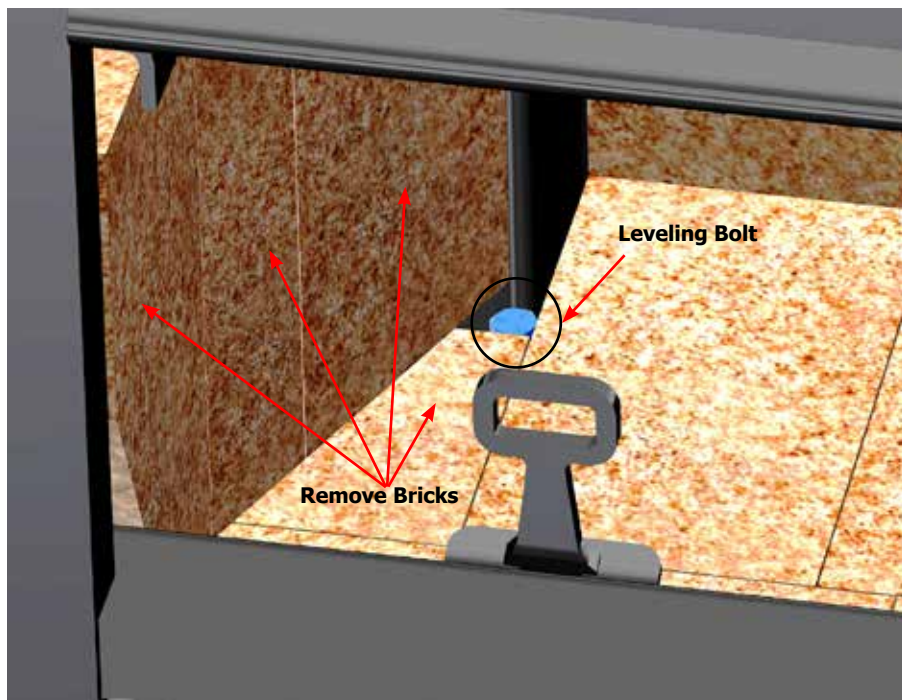
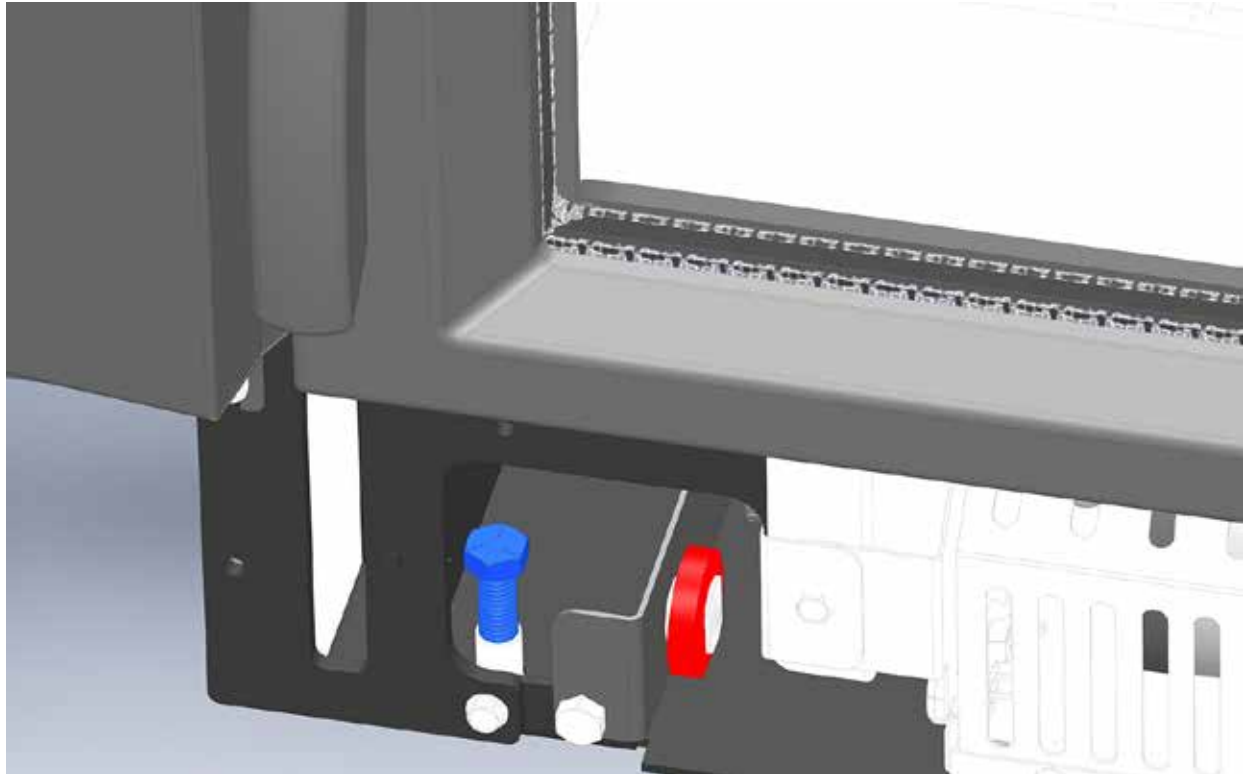

2. Remove the three side bricks on each side then remove the corner bottom/side cut brick to gain access to the rear leveling bolts. You can adjust using a 9/16" wrench or socket.

OPTIONAL CAST GRILL INSTALLATION

GLASS REMOVAL TO INSTALL OPTIONAL DOOR CAST GRILL

1. To remove the glass, remove the four retainer bolts (two top and two bottom) highlighted in the diagram.
2. Carefully remove the glass and the gasket frame assembly (shown).
3. Place the grill in the door.
4. Carefully install the glass and re-install the gasket frame assembly.
5. Reinstall the four retainer bolts removed in Step 1. Do not over tighten.
6. If the door does not close properly after adding the optional grill, an additional shim (supplied with grill) may be added to the door catch. This will ensure door closes with ease. See manual for details.

After several fires and once the door gasket begins to compress, the additional shim may be removed and saved for future use.

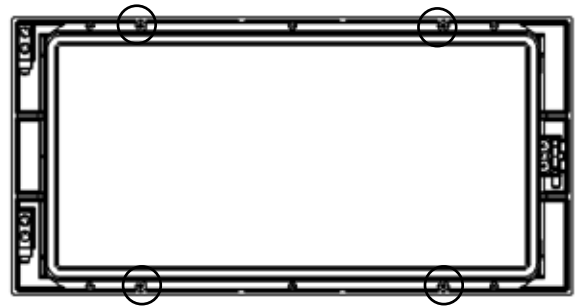

Remove 4 Bolts

Avoid impact on glass doors such as striking or slamming shut.

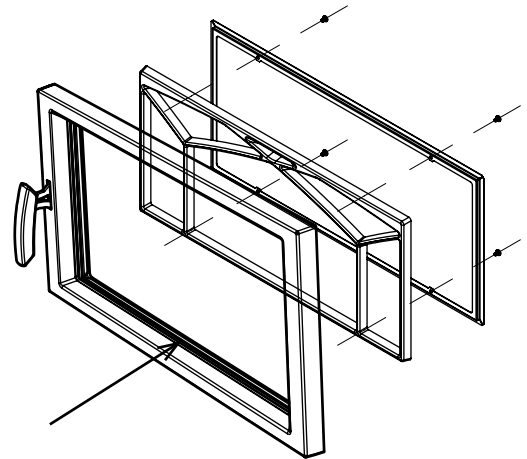

FIREBRICK ASSEMBLY

Firebrick is included to extend the life of your insert and radiate heat more evenly. Remove white Lytherm sheet from the wood insert and install on base of firebox prior to installing the firebrick. Install all firebricks per the diagram and place in their correct positions. Do not use a grate.

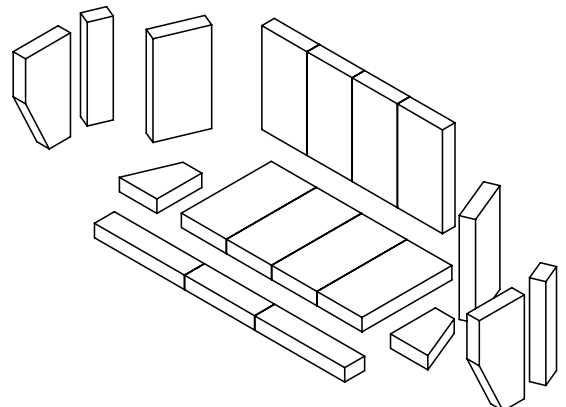

OPTIONAL BACKING PLATE INSTALLATION

1.

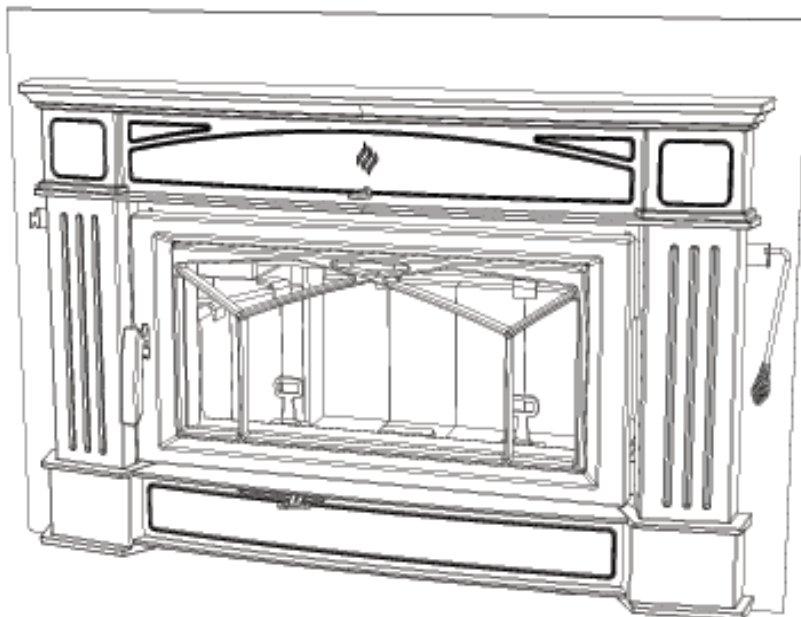
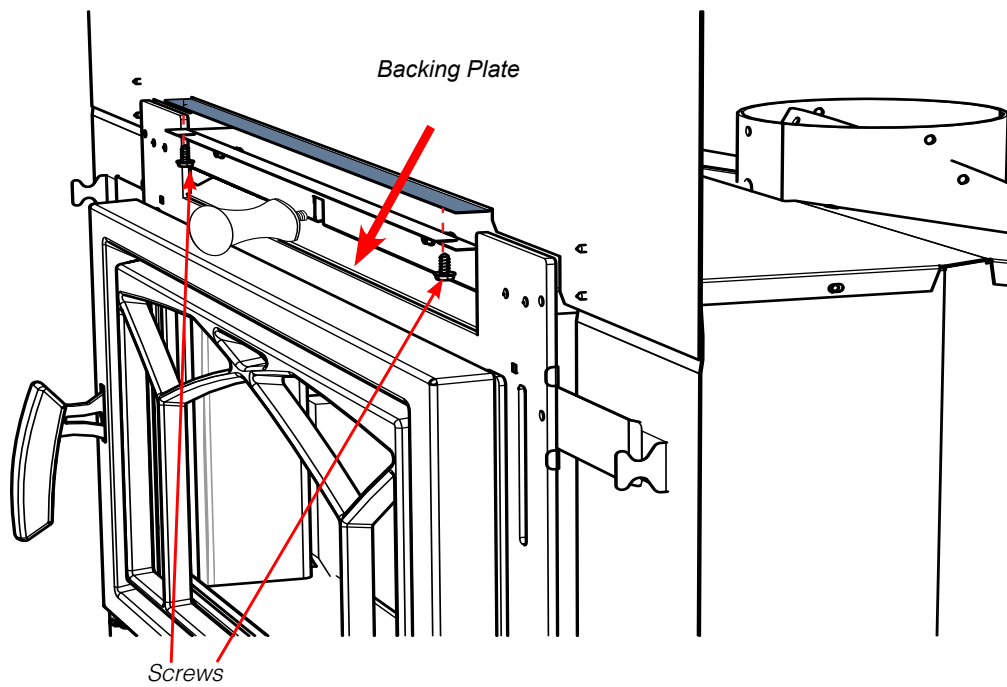
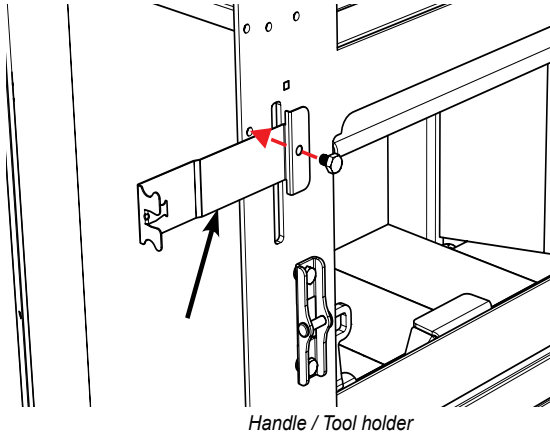

Diagram 4

CONTEMPORARY FACEPLATE INSTALLATION

NOTE:

1.



2.

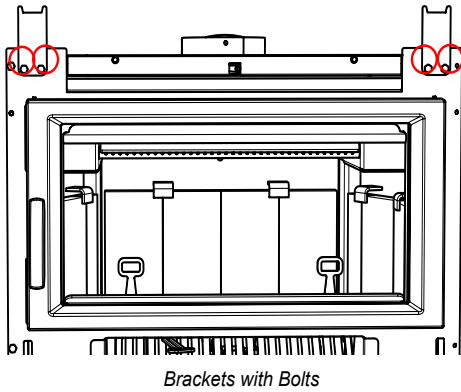

3.

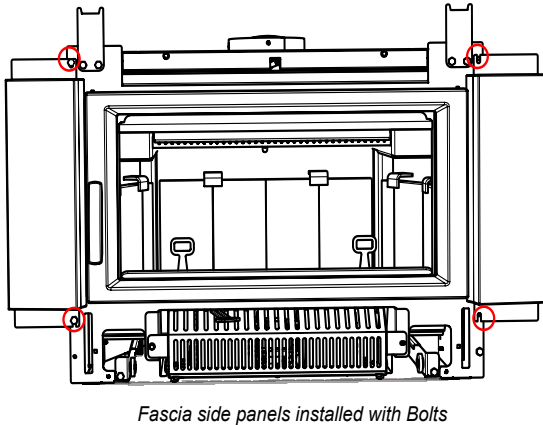

4.

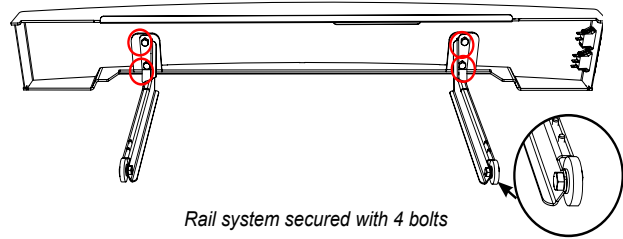

NOTE:

5.

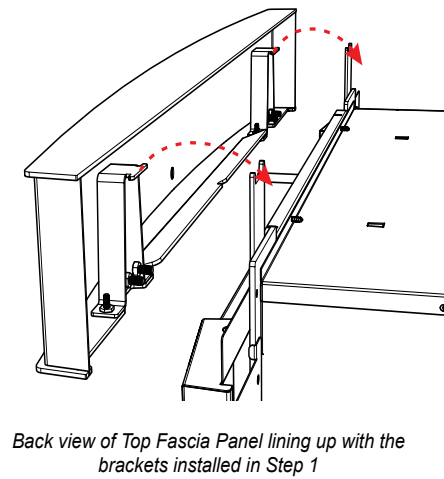
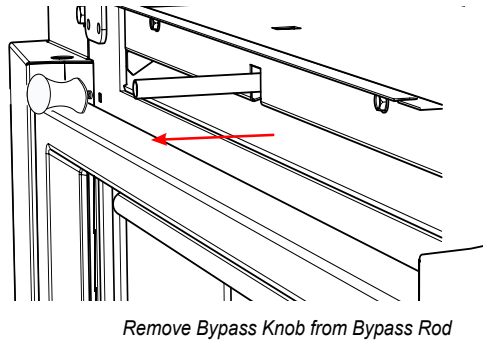

6.

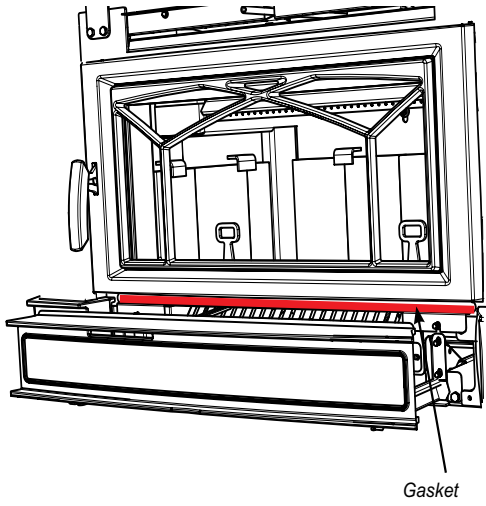

8.

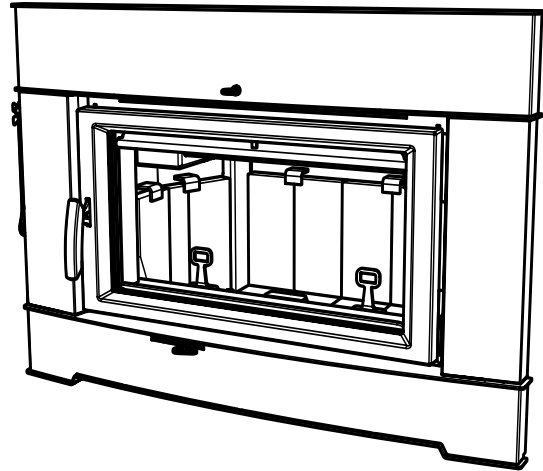

Final Install

7.

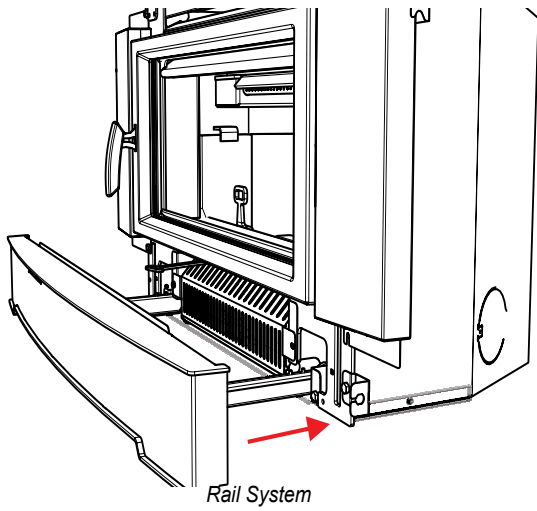

LOW PROFILE FACEPLATE INSTALLATION

NOTE: If installing blower, optional Fan cassette must be installed prior at this point. See fan installation instructions for details.
If not installing blower—proceed to Step 6.

1

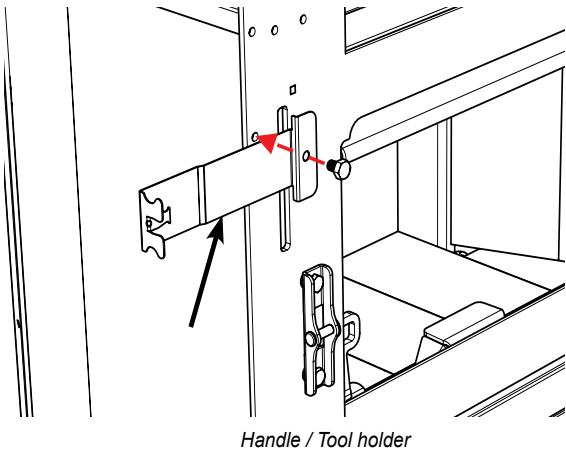

2

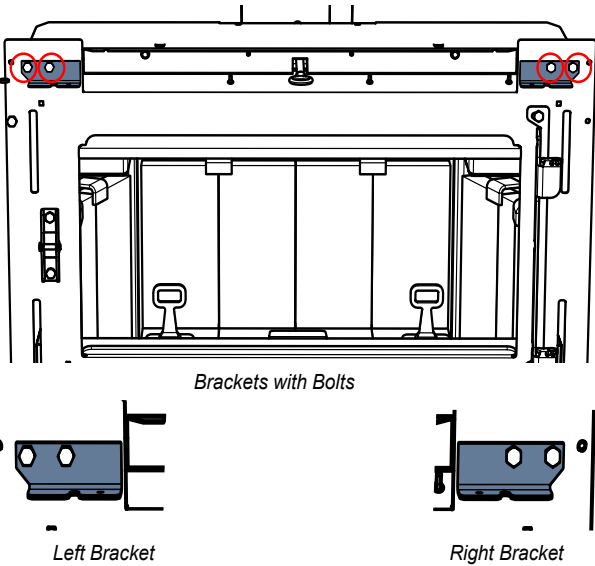

3

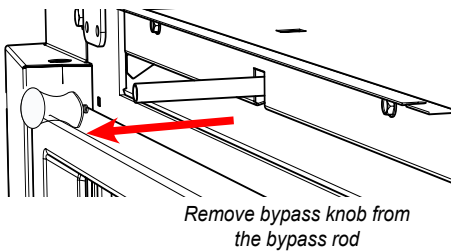

4

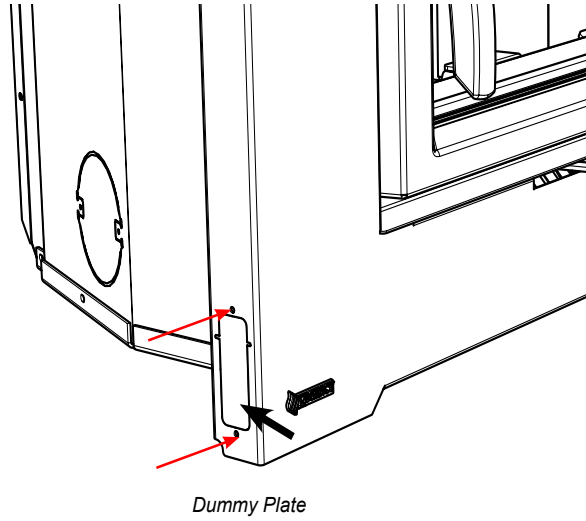

5

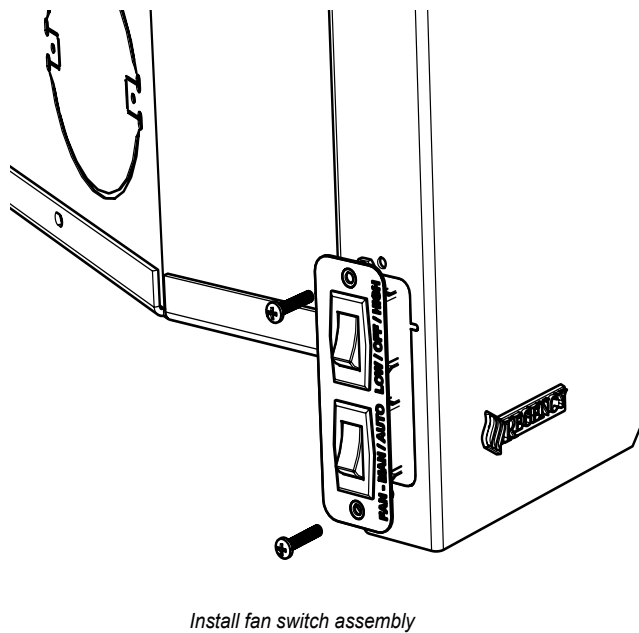

6.

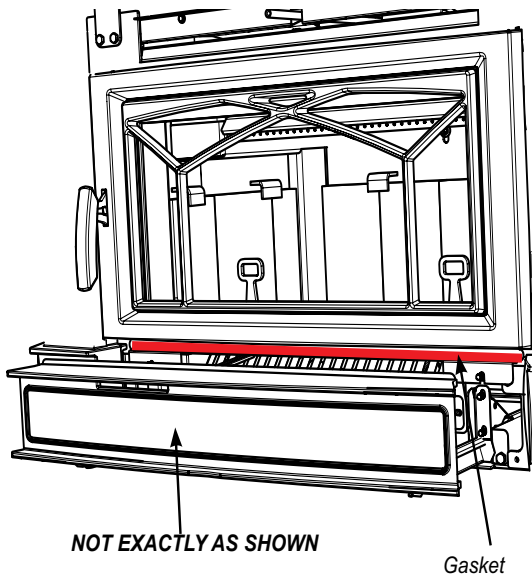

8

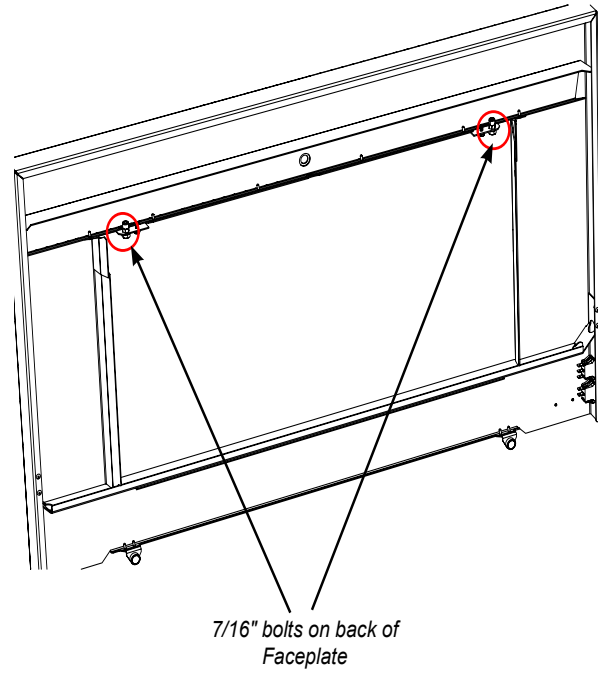

7.

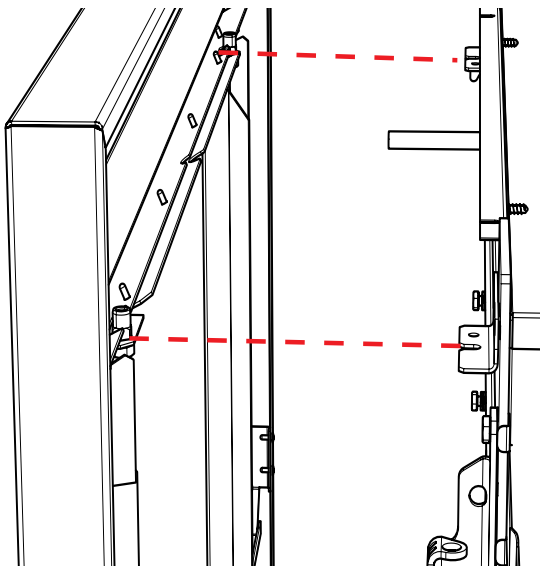

9.

10

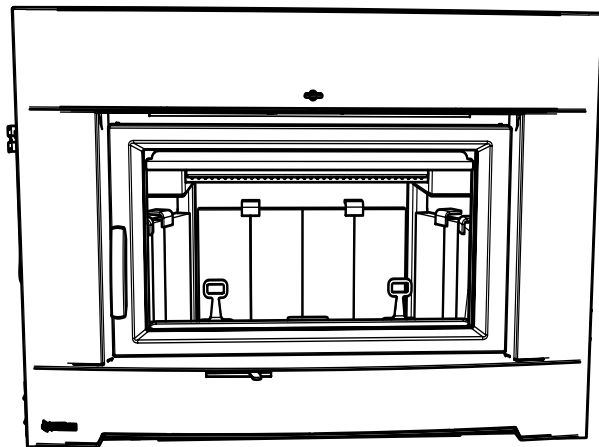

Final Install

CAST FACEPLATE INSTALLATION

1.

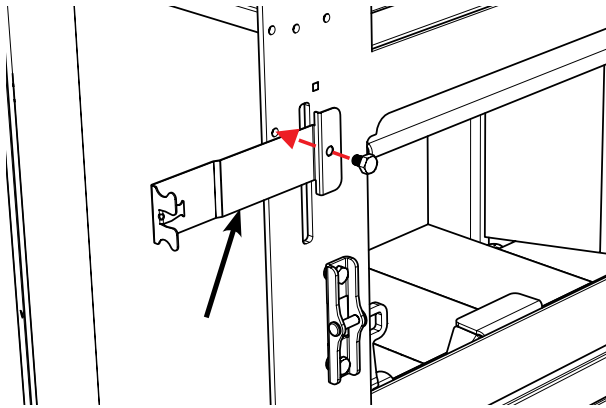

Handle / Tool holder

2.

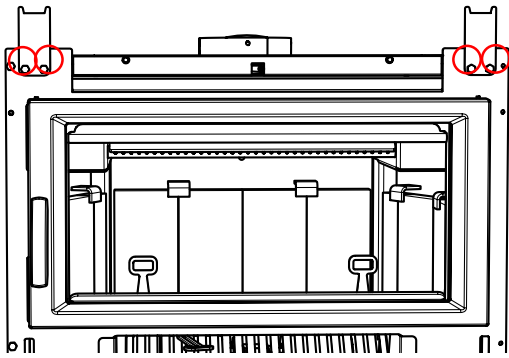

Brackets with Bolts

3.

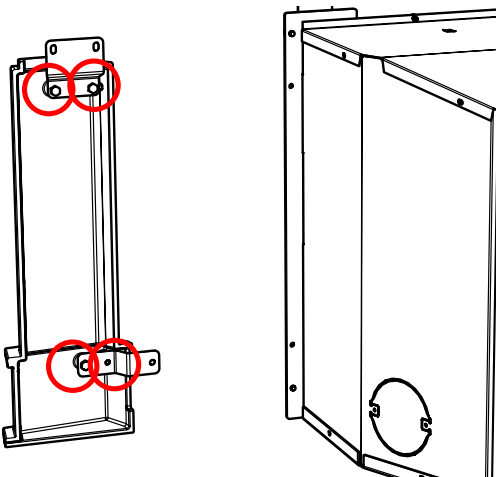

Cast Panel Shown

4.

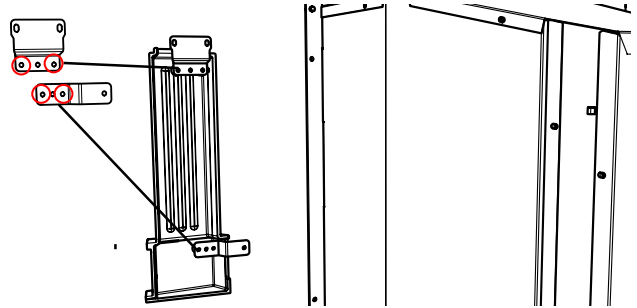

Enamel Panel Brackets

5.

NOTE:

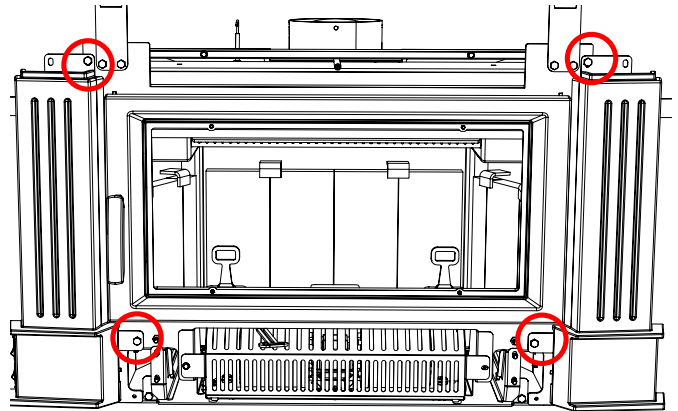

Fascia side panels installed with bolts

6.

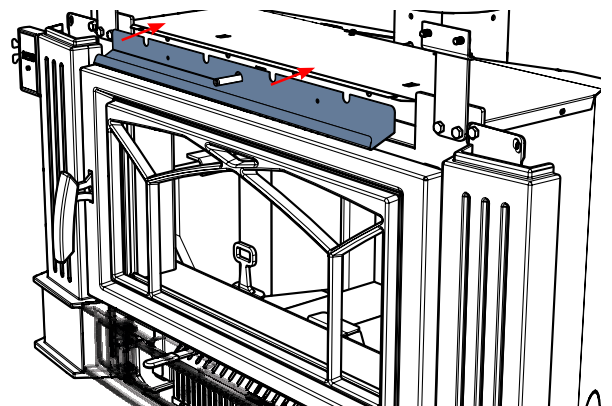

Fan deflector screw locations

7.

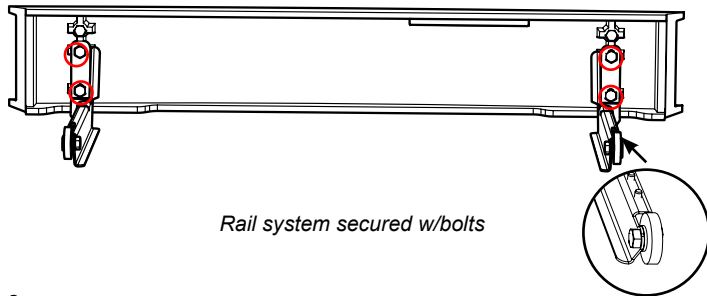

Rail system secured w/bolts

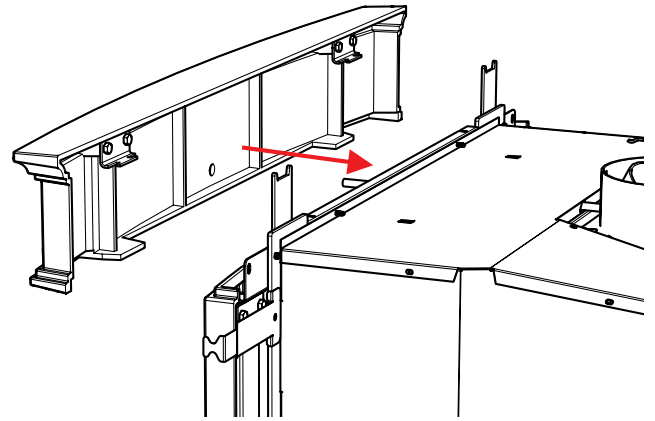

Back view of Top Fascia Panel lining up with the brackets installed in Step 1

8.

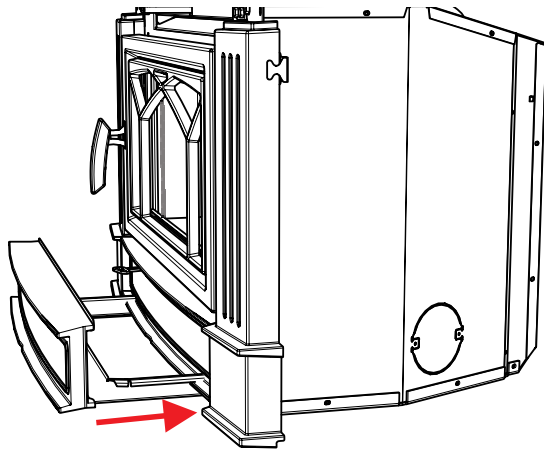

Rail System

10.

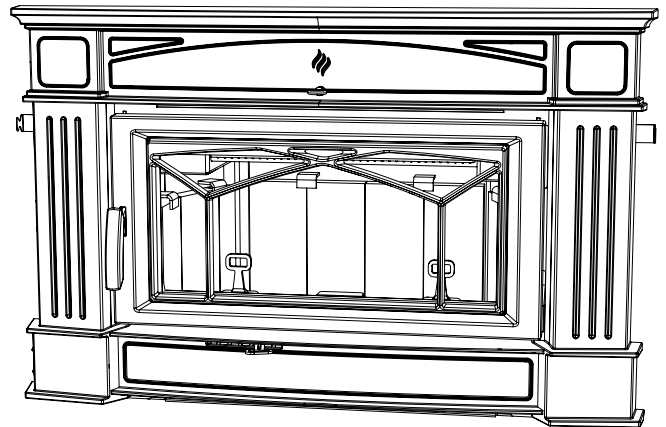

Completed Optional Hampton Cast Faceplate

9.

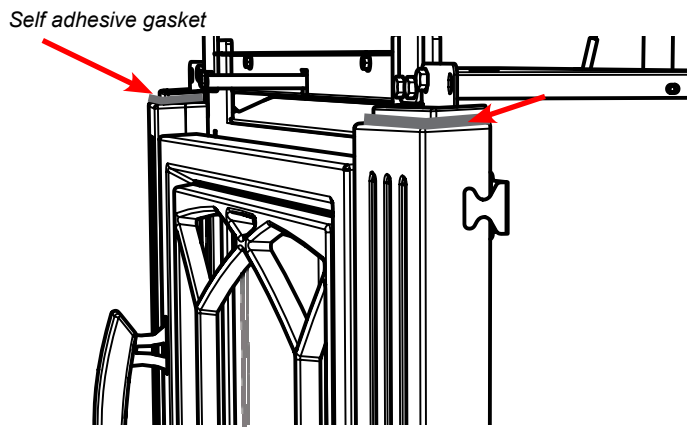

Self adhesive gasket

Note:

OVERSIZE CAST FACEPLATE INSTALLATION

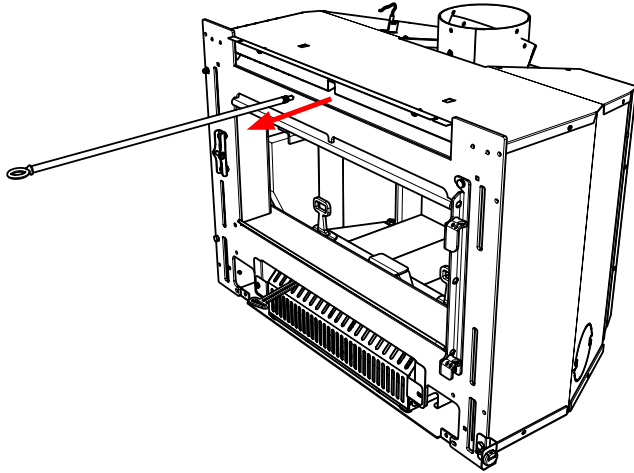

2.

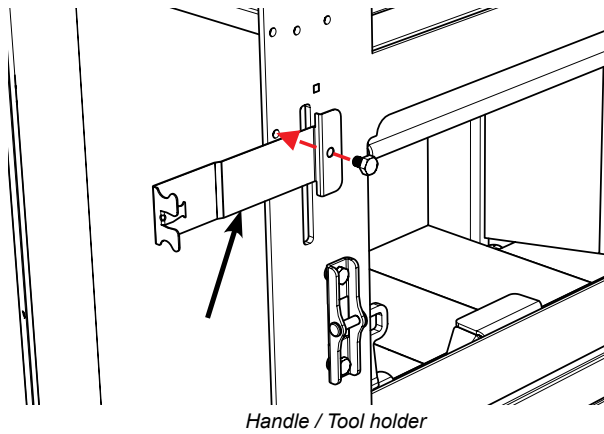

Handle / Tool holder

3.

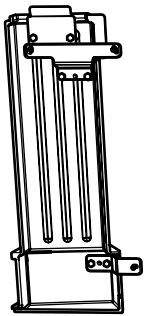

Right Panel/ Back Side

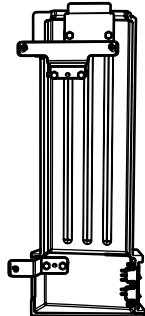

Left Panel/ Back Side

4.

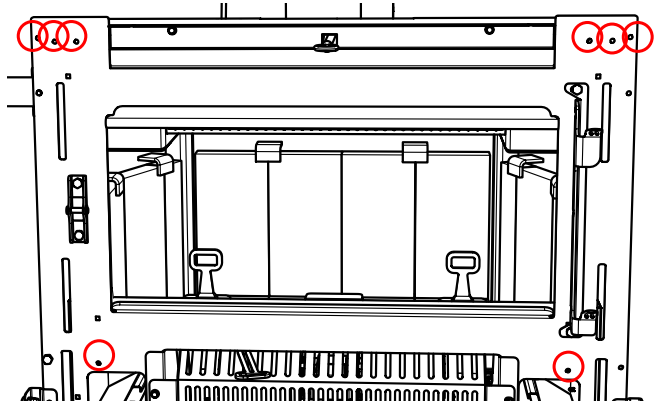

NOTE:

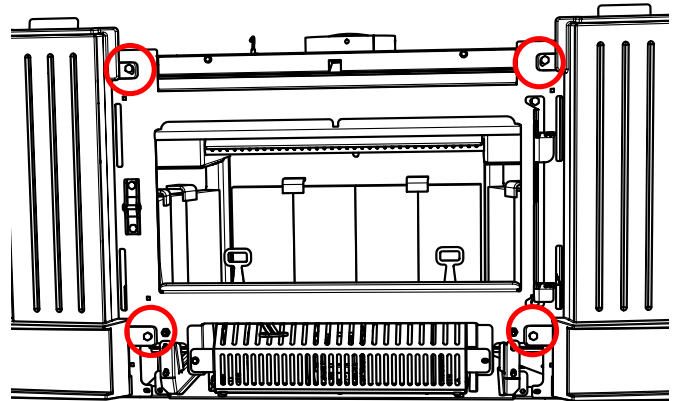

Fascia side panels installed with Bolts

5.

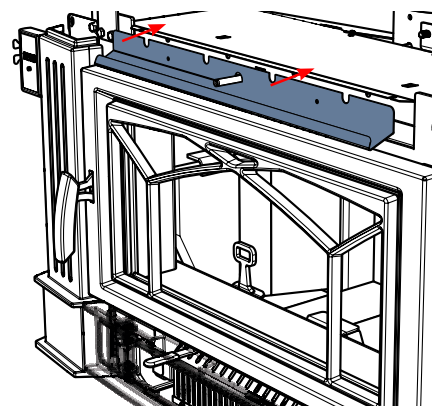

Fan deflector screw locations

5.

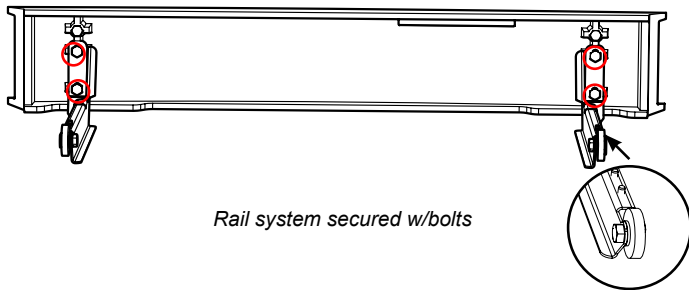

6.

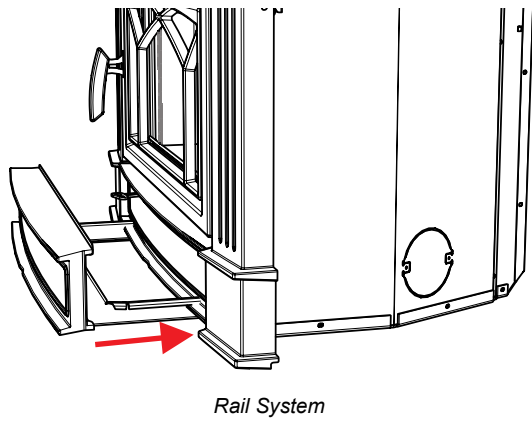
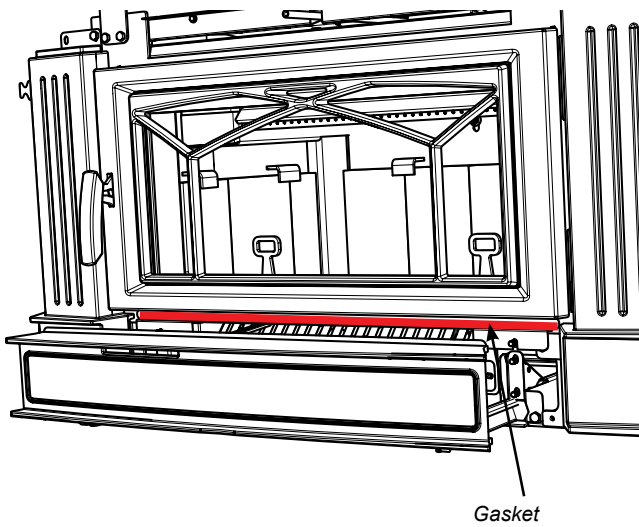

7.

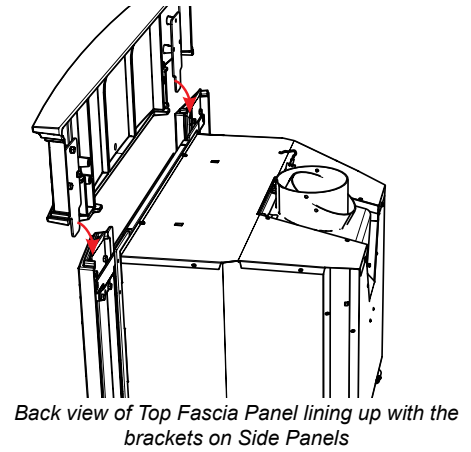
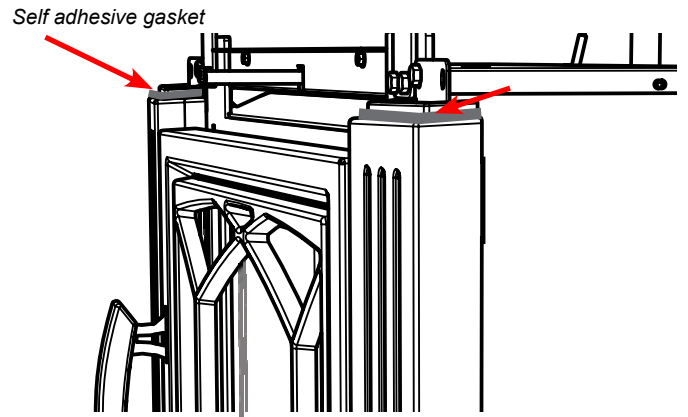

8.

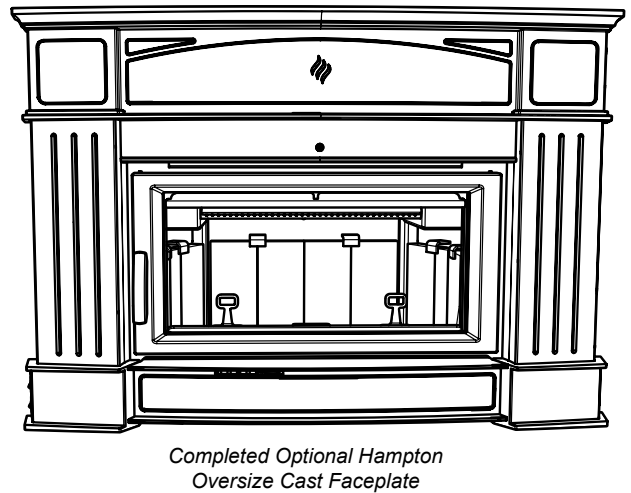

Note:

OPTIONAL FAN/BLOWER INSTALLATION

Installer: Please record unit serial number here before installing blower—serial number will not be visible after blower is installed.

Serial No. _____

The fan should only be installed once the unit is in place in order to prevent any damage to the fan.

1. Remove 2- 5/16" screws from locations shown below—set aside for installation.

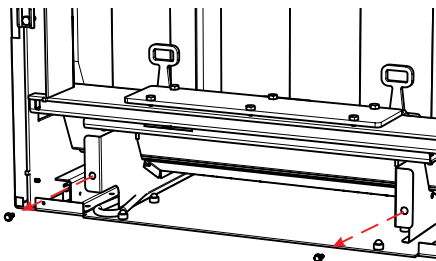

Remove 2 screws from locations shown

2. Slide the fan cassette fully into position.

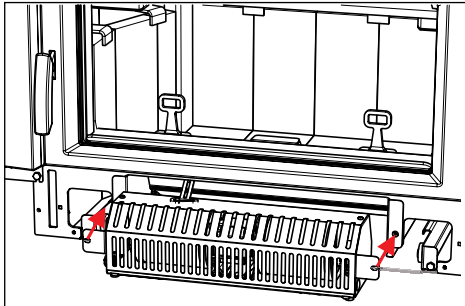

Line up fan cassette with screw holes.

3. Align screw holes on fan harness bracket with holes in fan cassette mounting bracket on right and left sides.



4. Secure using the two (2) 5/16" screws removed from Step 1.



Secure fan with 2 screws removed in Step 1

5. Remove 7/16" bolts from position shown below.

**See specific faceplate installation instructions for detailed instructions of fan switch assembly.

6. Align preset strain relief bracket to bottom right corner of the faceplate, secure with 7/16" bolt removed in Step 5.



Secure preset strain relief

7. Remove the dummy plug from the faceplate being installed, by removing the 2 screws along with washers and nuts. Discard dummy plug, but keep hardware. Install fan switch assembly with 2 screws, or use washers and nuts for Cast Faceplate to lower fascia before sliding faceplate into position.

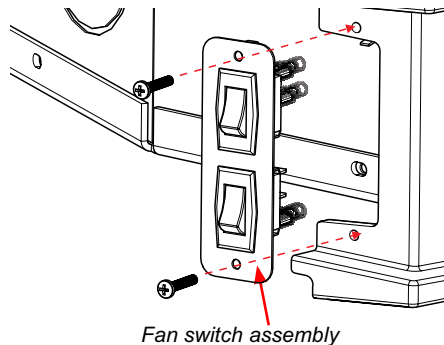

Fan switch assembly

NOTE: Avoid disconnecting wires from switch during installation.

8. Tuck Power Cord to the bottom right hand side of the faceplate as shown.



Tuck cord to right side of faceplate

Do not turn fan ON until your insert has reached operating temperature or at least 30 minutes after starting fire.

Important:

The blower to this appliance must be turned off anytime the fuel door is opened. Prior to turning the blower back on, ensure there are no embers near the blower which may have fallen onto the hearth when the fuel door was opened. Once the fuel door is closed, the blower may be turned back on.

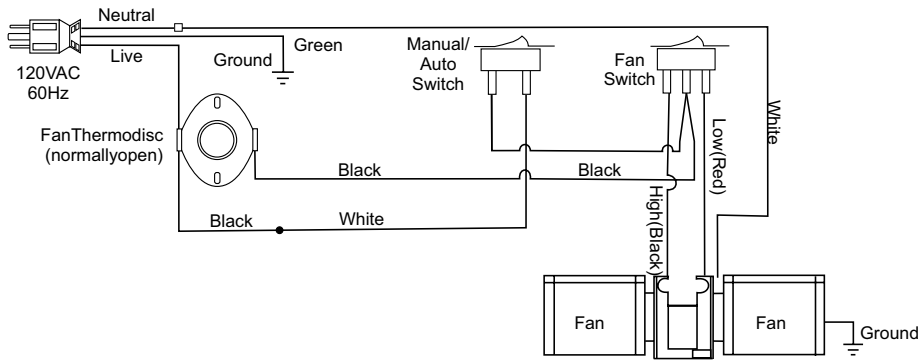

Blower/Fan Wiring Diagram

CAUTION: Label all wires prior to disconnection when servicing controls. Wiring errors can cause improper and dangerous operation.

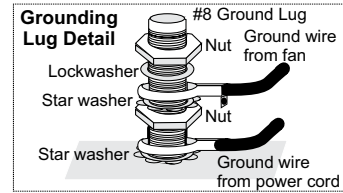

WARNING:
Electrical Grounding Instructions
 This appliance is equipped with a three pronged (grounding) plug for your protection against shock hazard and should be plugged directly into a properly grounded three-prong receptacle. Do not cut or remove the grounding prong from this plug.

REMOVABLE DOOR HANDLE

The CI2700/HI500 has a removable door handle that can be stored when not in use. All the faceplates have a storage hook on the left side that accommodates the handle.

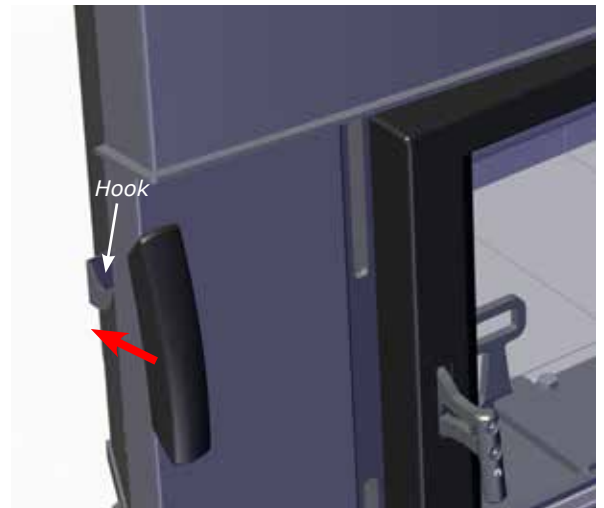

The cool to touch door handle is designed to be inserted from the bottom up and slide off when not held in place. Once in position, the door can be opened. After use, store the door handle on the storage hook located on the left side of the faceplate

WARNING: FAILURE TO USE REMOVABLE HANDLE AS PER INSTRUCTIONS MAY CAUSE SERIOUS BURNS.

BYPASS HANDLE

The CI2700/HI500 is supplied with a bypass operating handle. The handle is used to open or close the bypass when re-loading



SEASONED WOOD

Whether you burn wood in a fireplace, stove or insert, good quality firewood is the key to convenience, efficiency and safety. Wet wood and pieces that are not the right size and shape for your wood burner can be frustrating, burn inefficiently and deposit creosote that can fuel a dangerous chimney fire. Good planning, seasoning and storage of the firewood supply are essential to successful wood burning.

- Stack the wood in separate rows in an open location where the summer sun can warm it and breezes can carry away the moisture. Do not stack unseasoned wood tightly in an unvented storage area.
- Do not allow firewood to lie on the ground for more than a couple of days before stacking. Mould and rot can set in quickly.
- Stack the wood up off the ground on poles, lumber rails or pallets.
- The top of the pile can be covered to keep off rain, but do not cover the sides.

Softer woods like pine, spruce and poplar/aspen that is cut, split and stacked properly in the early spring maybe be ready for burning in the fall. Extremely hard woods like oak and maple, and large pieces of firewood, may take a minimum of a full year to dry enough. Drying may also take longer in damp climates

There are a few ways to tell if wood is dry enough to burn efficiently. Use as many indicators as possible to judge the dryness of the firewood your are considering. Here are ways to judge firewood moisture.

- Using a moisture meter, select the species of fuel and then penetrate the pins into a split piece. Ideal moisture and seasoned firewood should be less than 20% moisture content.
- Checks or cracks in the end grain can be an indication of dryness, but may not be a reliable indicator. Some wet wood has checks and some dry wood has no checks.
- The wood tends to darken from white or cream colour to grey or yellow as it dries.
- Two dry pieces banged together sound hollow; wet pieces sound solid and dull.
- Dry wood weighs much less than wet wood.
- Split a piece of wood. If the exposed surface feels damp, the wood is too wet to burn.

OPERATING INSTRUCTIONS

With your unit now correctly installed and safety inspected by your local authority, you are now ready to start a fire. Before establishing your first fire, it is important that you fully understand the operation of your Catalytic combustor and draft control.

WARNING

Fireplace Inserts equipped with doors should be operated only with doors fully closed. If doors are left partly open, gas and flame may be drawn out of the fireplace insert opening, creating risks from both fire and smoke.

DRAFT CONTROL

Both the primary and air wash drafts are controlled by the control slide located on the front left side of the unit (when facing the unit). To increase your draft - slide to the left to open, and to decrease - slide to the right to close. The CI2700/HI500 Wood Insert has a secondary draft system that continually allows combustion air to the induction ports at the top of the firebox, just in front of the catalytic combustor.

Draft is the force which moves air from the appliance up through the chimney. The amount of draft in your chimney depends on the length of the chimney, local geography, nearby obstructions and other factors. Too much draft may cause excessive temperatures in the appliance and may damage the catalytic combustor. Inadequate draft may cause back puffing into the room and plugging of the chimney or catalyst.

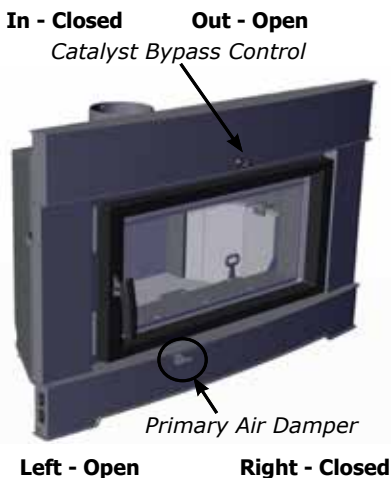

WARNING: To build a fire in ignorance or to disregard the information contained in this section can cause serious permanent damage to the unit and void your warranty!!

FIRST FIRE

When your installation is completed and inspected you are ready for your first fire.

THIS UNIT IS DESIGNED TO BURN SEASONED CORDWOOD ONLY. COAL, BRIQUETTES AND ALL OTHERS LISTED ON PAGE 2 ARE NOT APPROVED. SEASONED CORDWOOD SHOULD BE LESS THAN 20% MOISTURE CONTENT.

START UP AND OPERATING PROCEDURES:

1. For the first few days, the wood insert will give off an odour from the paint. This is to be expected as the high temperature paint becomes seasoned. Windows and/or doors should be left open to provide adequate ventilation while this temporary condition exists. Burning the wood insert at a very high temperature the first few times may damage the paint. During the first few fires, keep the combustion rate at a moderate level and avoid a large fire. Only after 5 or 6 such fires can you operate the wood insert at its maximum setting, and only after the metal has been warmed.

2. Do not place anything on the wood insert top during the curing process. This may result in damage to your paint finish.

3. When starting the fire, ensure the bypass is in the fully open position (pulled out) and air control is in the fully open position (far left). Crumble 2-5 pieces of newspaper and add approx. 1.8lbs of kindling stacked in a manner that allows air flow on the firebrick hearth (Teepee style or other). DO NOT USE A GRATE TO ELEVATE THE FIRE.

Light the newspaper and adjust the door if it is slightly ajar for less smoke roll out. Keep the door in that position for 2-3 minutes to establish a good fire.

4. Add additional 0.8lbs of kindling along with 1lb of start up cord wood (startup cordwood is slightly larger than kindling but not full pieces of cordwood). Close the door and establish flame for 2-3 minutes.

CAUTION: Never leave unit unattended if door is left open. This procedure is for fire start-up only, as unit may overheat if door is left open for too long.

5. Once flame has been established, open the door and add another 2lbs of start up cordwood. Hold door slightly ajar for 30-60 sec to establish flame, and then close the door and bypass.

6. After 5-7 minutes, go ahead and add another 2lbs of startup fuel and establish flame and close the door.

NOTE: These steps are crucial to ensure proper charcoalization and coal bed prior to loading High, Med and Low fire loads.

7. Once this has burned down, open the door and the bypass, and rake the coals to create a uniform charcoal bed. Load 5 pcs of 17" long cordwood, East-West orientation, with the heaviest pieces at the back of the firebox, and ensure all pieces are behind the log retainers. Once loaded, close the door right away and bypass. Burn on high setting (air control to the far left when facing the unit) for 10-15 minutes. After the 10-15 minutes, adjust the air control to your desired position.

High Fire: Air control to far left.

Low Fire: Air control to far right.

Med Fire: Air control slightly left of low fire setting.

8. **IMPORTANT:** The temperature in the wood insert and the gases entering the combustor must reach between 500°F - 700°F for catalytic activity to start. From the start up of a cold wood insert, a medium to high firing rate must be maintained for 30 min. This ensures that the wood insert, catalyst and fuel are all stabilized at proper operating temperatures. Even though it is possible to have temperatures at 600°F within minutes after a fire has been started, if the fire is allowed to die down immediately it may go out or the combustor may stop working. Once the combustor starts working, heat generated in it by burning the smoke will keep it working. During re-fueling and rekindling of the cool fire, or a fire that has burned down to the charcoal phase, operate the wood insert at a medium to high firing rate for about 10 minutes to ensure that the catalyst reaches operating temperatures.

WARNING: Never build a roaring fire in a cold wood insert. Always warm your wood insert up slowly!

9. When re-fueling, always open by-pass control, and primary air damper, load fuel, then wait for at least 10-15 minutes before closing the by-pass. Reason for the 10-15 min. is the fresh fuel and the opening of the door will cause the catalyst to drop in temperature as well as the moisture within the wood which is the first thing to be released. This will also minimize any smoking (spilling) back into the room.

10. During the first few days it may be more difficult to start the fire. As you dry out your firebrick and your masonry flue, your draft will increase.

11. For those units installed at higher elevations or into sub-standard masonry fireplaces, drafting problems may occur. Consult an experienced dealer or mason on methods of increasing your draft.

12. Some cracking and popping noises may be experienced during the heating up process. These noises will be minimal when your unit reaches temperature.

13. All fuel burning appliances consume oxygen during operation. It is important that you supply a source of fresh air to your unit while burning. A slightly opened window is sufficient for the purpose. If you also have another fireplace in your home, a downdraft may be created by your Regency wood insert causing a draft down your chimney. If this occurs, slightly open a window near your unit.

CAUTION: If the body of your wood insert, or any part of the chimney connector starts to glow, you are over firing. Stop loading fuel immediately and close the draft control until the glow has completely subsided.

14. Green or wet wood is not recommended for your unit. If you must add wet or green fuel, open the draft control fully until all moisture has been dispersed by the intense fire. Once all moisture has been removed, the draft control may be adjusted to maintain the fire.

15. If you have been burning your stove on a low draft, use caution when opening the door. After opening the damper, open the door a crack, and allow the fire to adjust before fully opening the door.
16. The controls of your unit or the air supply passages should not be altered to increase firing for any reason.
17. If you burn the unit too slowly or at too low a setting your unit will not be operating as efficiently as it can. An easy rule of thumb says that if your glass is clean, catalytic thermostat is active, then your flue is clean and your exhaust is clean. Burn the stove hot enough to keep your glass clean and catalytic combustor, you won't need to clean your flue as often.

HOT WHILE IN OPERATION. KEEP CHILDREN, CLOTHING AND FURNITURE AWAY. CONTACT MAY CAUSE SKIN BURNS.

ASH DISPOSAL

During constant use, ashes should be removed every few days. Please take care to prevent the build-up of ash around the start-up air housing located inside the firebox, under the loading door lip.

DO NOT ALLOW ASHES TO BUILD UP TO THE LOADING DOORS.

Only remove ashes when the fire has died down. Even then, expect to find a few hot embers. Always leave 1 to 2 inches of ash in the bottom of the firebox. This helps in easier starting and a more uniform burn of your fire.

Ashes should be placed in a metal container with a tight fitting lid. The closed container of ashes should be placed on a noncombustible floor or on the ground, well away from all combustible materials, pending final disposal. If the ashes are disposed of by burial in soil or otherwise locally dispersed, they should be retained in the closed container until all cinders have thoroughly cooled. Other waste should not be placed in the ash container.

FAN OPERATION

The fan unit must not be turned on until a fire has been burning for at least 30 minutes and the unit is hot enough. As well, after each fuel loading the fan must be shut off until 30 minutes has elapsed.

To operate fan automatically, push switch on side of fan housing to "Auto" and second switch to either "High" or "Low" for fan speed. The automatic temperature sensor will engage the blower when the unit is at temperature and will shut off the blower once the fire has gone out and the unit has cooled to below a useful heat output range.

To manually operate the fan system, push the first switch to "Man" and second switch to either "high" or "Low". This will bypass the sensing device and allow full control of the fan. Switching from "Auto" to "Manual" or "High" to "Low" may be done at any time.

To achieve maximum efficiency and performance, operate the fan in the low speed when the air control is not more than 1/4" open from its lowest setting. See draft control instructions for operation of air control.

When the appliance is cool it is important to clean in and around the fan. Always ensure areas on the hearth are clean and ashes, debris etc. are not pushed towards the bottom of the fascia. Always brush and clean debris away from the unit, not towards.

CREOSOTE

When wood is burned slowly, it produces tar and other organic vapors, which form creosote when combined with moisture. The creosote vapors condense in the relatively cool chimney flue of a slow-burning fire. As a result, creosote residue accumulates on the flue lining. When ignited, this creosote can make an extremely hot fire.

For wood-burning heaters, reference to the formation and removal of creosote buildup in the chimney connector and chimney as follows (the inspection frequency "once every two months" stated below may be a shorter time period at the manufacturer's or private labeler's options):

"Creosote - Formation and Need for Removal

The chimney connector and chimney should be inspected at least once every two months during the heating season to determine if a creosote buildup has occurred.

If creosote has accumulated it should be removed to reduce the risk of chimney fire.

REMOVAL FOR CLEANING

Removal of your insert for cleaning purposes is usually not required if a proper installation has been done. In the event that removal is required, be sure not to damage any parts needed for re-installation. In most cases removal and replacement of the baffle system should allow full access for cleaning.

WARNING: In case of chimney fire:

1. Close draft control
2. Call the Fire Department

WAYS TO PREVENT AND KEEP UNIT FREE OF CREOSOTE

1. Burn insert with draft control wide open for about 45 minutes every morning during burning season. This helps to prevent creosote deposits within the heating system.
2. Burn insert with draft control wide open for about 10 - 15 minutes every time you add fresh wood. This allows the wood to achieve the charcoal stage faster and burns up any wood vapors which might otherwise be deposited within the system.
3. **Only burn seasoned wood!** Do not burn wet or green wood. Seasoned wood that has been dried at least one year must be used.

4. A small hot fire is preferable to a large smouldering one that can deposit creosote within the system.
5. Check the chimney at least twice a month during the burning season for creosote build-up.
6. **Have chimney system and unit cleaned by competent chimney sweeps twice a year during the first year of use and at least once a year thereafter or when a significant layer of creosote has accumulated (3mm / 1/8" or more) it should be removed to reduce the risk of a chimney fire.**

WOOD STORAGE

Store wood under cover, such as in a shed, or covered with a tarp, plastic, tar paper, sheets of scrap plywood etc., as uncovered wood can absorb water from rain or snow, delaying the seasoning process.

SAFETY GUIDELINES & WARNINGS

DO NOT USE CHEMICALS FOR FLUIDS TO START FIRE.

CAUTION

1. Never use gasoline, gasoline type lantern fuels, kerosene, charcoal lighter fuel, or similar liquids to start or 'freshen up' a fire in your heater. Keep all such liquids well away from the heater while it is in use.
2. Keep the door closed during operation and maintain all seals in good condition.
3. Do not burn any quantities of paper, garbage, and never burn flammable fluids such as gasoline, naphtha or engine oil in your stove.
4. If you have smoke detectors, prevent smoke spillage as this may set off a false alarm.
5. Do not overfire heater. If the chimney connector, flue baffle or the stove top begin to glow, you are over firing. Stop adding fuel and close the draft control. Over firing can cause extensive damage to your stove including warping and premature steel corrosion. Over firing will void your warranty.
6. Do not permit creosote or soot build-up in the chimney system. Check and clean chimney at regular intervals. Failure to do so can result in a serious chimney fire.
7. Your Regency stove can be very hot. You may be seriously burned if you touch the stove while it is operating, keep children, clothing and furniture away. Warn children of the burn hazard.
8. The stove consumes air while operating, provide adequate ventilation with an air duct or open a window while the stove is in use.
9. Do not connect this unit to a chimney flue serving another appliance.
10. Do not use grates, andirons or other methods for supporting fuel. Burn directly on the bricks.

SAFETY GUIDELINES & WARNINGS

- 11. Open the draft control fully for 10 to 15 seconds prior to slowly opening the door when refuelling the fire.
- 12. Do not connect your unit to any air distribution duct.
- 13. This heater is designed to burn natural wood only. Higher efficiencies and lower emissions generally result when burning air dried seasoned hardwoods, as compared to softwoods or to green or freshly cut hardwoods.
- 14. Do not store any fuel closer than 2 feet from your unit. Do not place wood, paper, furniture, drapes or other combustibles near the appliance.
- 15. **Do not operate with cracked/broken, plugged, or glazing catalyst.**

DO NOT BURN:

- Treated wood
- Coal
- Garbage
- Cardboard
- Solvents
- Colored Paper
- Trash
- Salt drift wood
- Cut lumber, plywood, mill ends.

Burning treated wood, garbage, solvents, colored paper or trash may result in release of toxic fumes and may poison or render ineffective the catalytic combustor. Burning coal, cardboard, or loose paper can produce soot, or large flakes of char or fly ash that can coat the combustor, causing smoke spillage into the room, and rendering the combustor ineffective.

IMPORTANT : It is against federal regulation to operate this wood heater in a manner inconsistent with operating instructions in this manual, or if the catalytic element is deactivated or removed.

DO NOT BURN GARBAGE OR FLAMMABLE LIQUIDS SUCH AS GASOLINE, NAPHTHA OR ENGINE OIL. SOME FUELS COULD GENERATE CARBON MONOXIDE AND ARE VERY DANGEROUS.

- 16. The controls of your unit or the air supply passages should not be altered to increase firing for any reason.
- 17. If you burn the unit too slowly or at too low a setting your unit will not be operating as efficiently as it can. An easy rule of thumb says that if your glass is clean, catalytic thermostat is active, then your flue is clean and your exhaust is clean. Burn the stove hot enough to keep your glass clean and catalytic combustor, you won't need to clean your flue as often.

CAUTION: DO NOT CONNECT TO, OR USE IN CONJUNCTION WITH ANY AIR DISTRIBUTION DUCT WORK UNLESS SPECIFICALLY APPROVED FOR SUCH INSTALLATION.

Troubleshooting Guide		
PROBLEM	POSSIBLE CAUSE	SOLUTION
Crumbling Substrate	Extreme Thermal Shock Refueling with Wet Wood High Draft	Bypass combustor when the stove is running Use seasoned, dried wood. Do not exceed .06" of water draft. Install a manual damper and draft gauge or a barometric damper.
Fly-Ash Build-up Fly-Ash Masking Fly-ash Plugging	Combustor has not maintained light-off temperature. Combustor has not maintained light-off temperature. Burning materials that produce a lot of char and fly-ash. Closing the bypass too soon	Brush cold combustor with a soft bristled brush or vacuum lightly. Brush cold combustor with a soft bristled brush or vacuum lightly. Do not burn cardboard, gift wrap or garbage. Follow instructions for proper light-off.
Thermal Cracking	Uneven temperatures, flame impingement and heat spikes.	If cracking causes large pieces to fall out, replace combustor.
Mechanical Cracks	Combustor mishandled or abused. Distortion of combustor holder.	Handle combustor with care. Replace if necessary. Replace combustor is large pieces are missing, replace any warped stove parts as well.
Plugging (Creosote)	Burning wet, pitchy woods or burning large loads of small diameter wood with the combustor in the operating position without light-off ever occurring.	Burn dried seasoned wood. Make sure combustor has light-off before closing the bypass damper. It may be possible to burn off the soot or creosote accumulation by putting the combustor in a partially open and partially closed position after a hot fire has been started.
Masking (Soot)	Combustor has not maintained a light-off. Burning coal will cause a sulfur-based compound to coat the catalyst.	Place combustor in a partially open and partially position after a hot fire has been started to burn off the soot accumulation. Revert to burning wood and fire the combustor to elevated temperatures for one hour.

CATALYTIC COMBUSTOR (PART # 106-534)

ACHIEVING AND MAINTAINING CATALYST LIGHT-OFF:

There are some obvious signs of trouble that your inspection may reveal. The temperature in the stove and the gases entering the combustor must be raised to between 500F to 700F for catalytic activity to be initiated. During the start up of a cold stove a medium to high firing rate must be maintained for about 30 minutes. This ensures that the stove, catalyst and fuel are all stabilized at proper operating temperatures. Even though it is possible to have temperatures at 600F within minutes after a fire has been started, if the fire is allowed to die down immediately it may go out or the combustor may stop working. Once the combustor starts working, heat generated in it by burning the smoke will keep it working. During re-fueling and rekindling of the cool fire, or a fire that has burned down to the charcoal phase, operate the stove at a medium to high firing rate for about 10 minutes to ensure that the catalyst reaches operating temperatures.

CATALYST MONITORING: It is important to periodically monitor the operation of the catalytic combustor to ensure that it is functioning properly and to determine when it needs to be replaced. A non-functioning combustor will result in a loss of heating efficiency, and an increase in creosote and emissions. Following is a list of items that should be checked on a periodic basis.

- Combustors should be visually inspected at least three times during the heating season to determine if physical degradation has occurred. Actual removal of the combustor is not recommended unless more detailed inspection is warranted because of decreased performance. If any of these conditions exist, refer to Catalyst trouble shooting section of this owner’s manual.
- A good combustor is designed to withstand approximately 12,000 hours of continuous use. This will translate into five to ten years of use, depending on the length of your heating season and how often you use your stove. Proper maintenance will increase the combustor’s effectiveness and prevent many problems. Inspect your combustor before each heating season, and during the season if your stove’s performance seems to change.
- You can get an indication of whether the catalyst is working by comparing the amount of smoke leaving the chimney when the smoke is going through the combustor and catalyst light – off has been achieved, to the amount of smoke leaving the chimney when the smoke is not routed (bypass open) through the combustor.

- Step 1:** Light the stove in accordance with instructions within this manual.
- Step 2:** With smoke routed through the catalyst (by-pass closed) go outside and observe the emissions leaving the chimney.
- Step 3:** Engage the bypass mechanism and move to by-pass open position. And again observe the emission leaving the chimney. Significantly more smoke should be seen when the smoke is not routed through the combustor (by-pass open). Be careful not to confuse smoke with steam.

ACHIEVING PROPER DRAFT: Draft is the force which moves air from the appliance up through the chimney. The amount of draft in your chimney depends on the length of the chimney, local geography, nearby obstructions and other factors. Too much draft may cause excessive temperatures in the appliance and may damage the catalytic combustor. Inadequate draft may cause back puffing into the room and plugging of the chimney or catalyst.

CATALYTIC COMBUSTOR CLEANING:

Method #1
A vacuum cleaner may be used, but never use high pressured air to blow the cells free of any build-up. This can damage the cell walls. Any cell blockage can be removed with the use of a pipe cleaner or a cotton swab as well.
Method #2
Should the combustor’s cells become covered with fly-ash, use a paint-brush or soft-bristled brush and dust the combustor gently. Never use anything abrasive to clean the combustor.
Method #3
Normally the catalytic combustor requires little or no maintenance, it generates such high temperatures and therefore is basically self-cleaning. However, should the combustor become covered with soot or creosote, it is possible to burn the accumulation off by opening the bypass and building a hot fire. Once the hot fire is created, close the bypass halfway and burn for 30 to 60 minutes with the bypass left in this position. Never use cleaning solvents to clean it. Check and clean the combustor, if necessary, before each burning season and inspect the flue system for any signs of creosote buildup.
A clean flue helps prevent chimney flue fires.

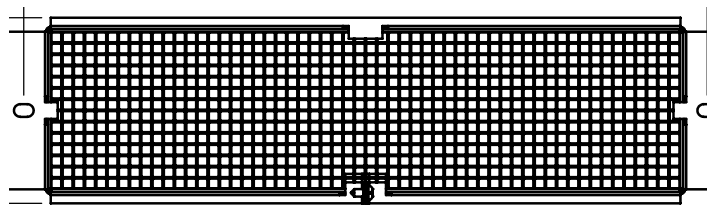

**COMBUSTOR ASSEMBLY
REMOVAL / REPLACEMENT:**

If the combustor must be examined or replaced, follow this procedure:

1. Allow the stove to burn out and cool down.
2. Open the door and loosen the two 7/16" bolts -see locations below.

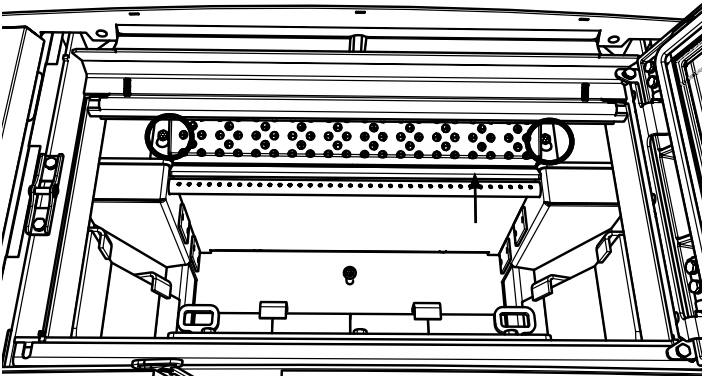

3. Lift flame shield slightly upwards in keyhole slot and pull it forward and down.
4. Use a pair of pliers and gently slide out the band at each end. The assembly will loosen enough that it can be pulled forward, lowered, and pulled out through the door.

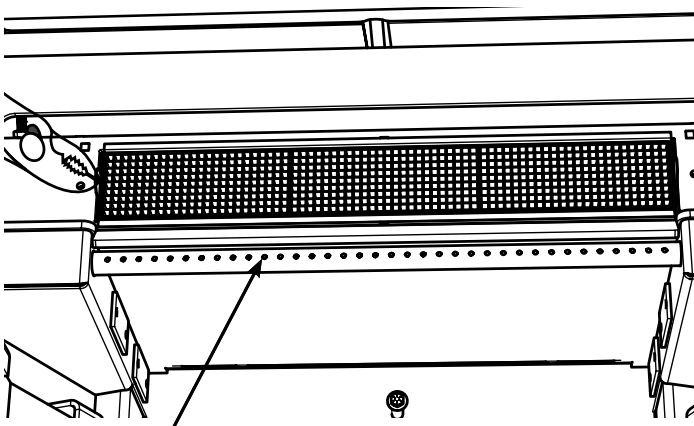

CI2700/HI500 Airtube

NOTE: If also replacing the gasket in the bypass door (see next page), remove the lid of the bypass door while it is accessible and complete steps in Bypass Door Gasket Replacement.

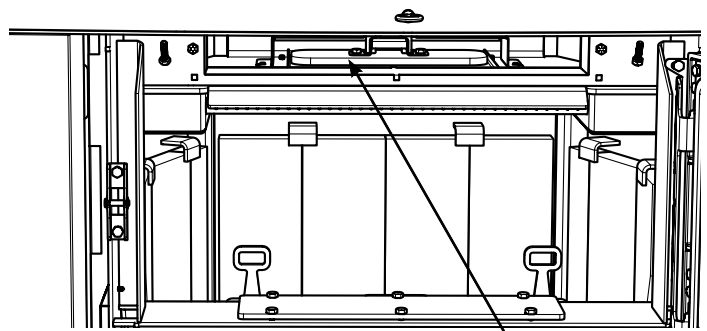

Lid for Bypass Door

TO REPLACE THE COMBUSTOR:

First clean the combustor area and the area around the by-pass, use a vacuum cleaner.

Lift the new combustor into position, with the stainless flanges on each end facing forward. The combustor should slide easily into position, you may need to pinch down the top center with your finger to start, gently push as far to the back of the stove as possible.

Replace the flame shield in the orientation shown below.

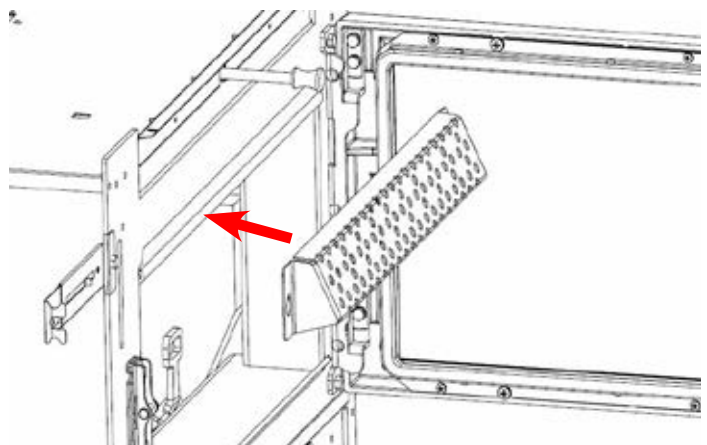

Lift it into position, place the key slot opening over the bolt and push the flame shield down to seat. Tighten the bolt till its SNUG only, do not over tighten. The flame shield should rest at an angle (about 45 degrees) with the thin end at the bottom and the thick end near the top of the stove.

NOTE: Replacement combustors can be retrieved from Applied Ceramics or Contact your local Regency Dealer for details.

DO NOT OPERATE THE APPLIANCE IF COMBUSTOR BECOMES INACTIVE - DO NOT OPERATE WITHOUT COMBUSTOR.

BYPASS DOOR GASKET REPLACEMENT

1. Remove bypass rod - turn counter clockwise.

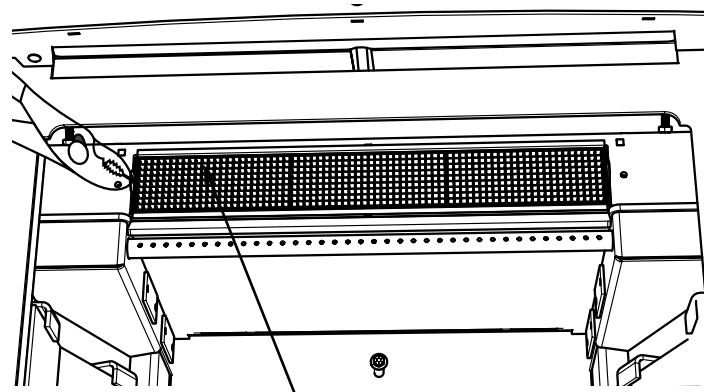
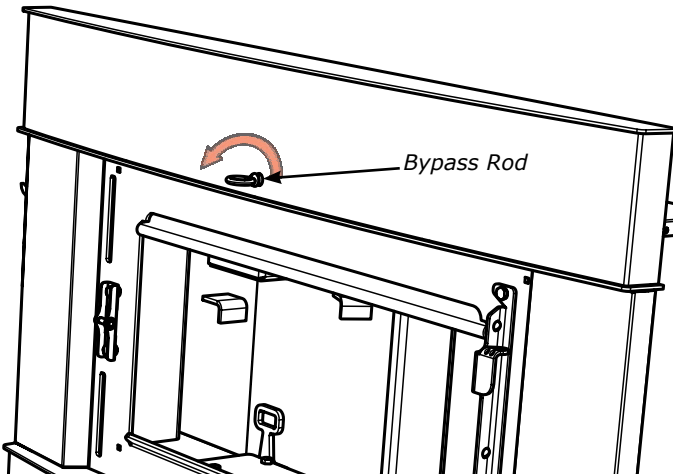

D- Combustor- remove with pliers
Tilt down and forward to ease removal.

2. The following parts must be removed to allow access and a positive connection.

- a) Primary Air Shield
- b) Combustor Flame Shield
- c) Combustor
- d) Upper shield

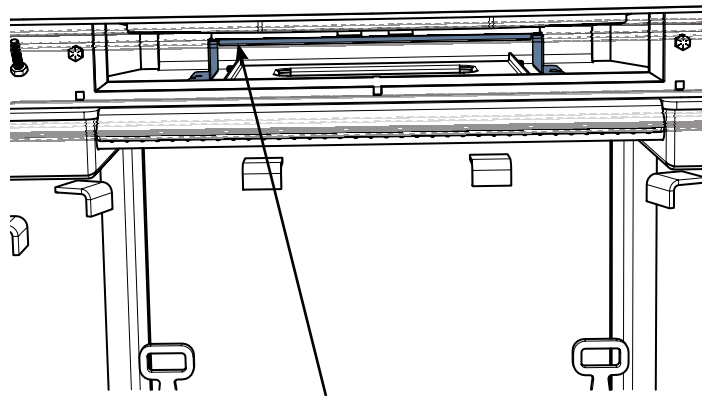

E- Upper Shield - slide forward and lift up to remove.

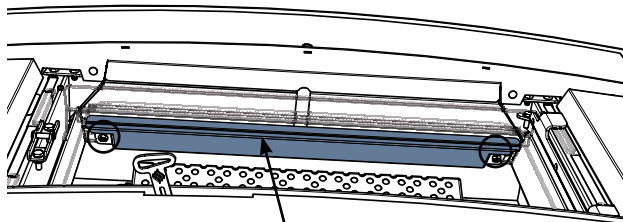

A- Primary Air Shield - loosen 2 x 7/16" bolts - slide forward to remove.

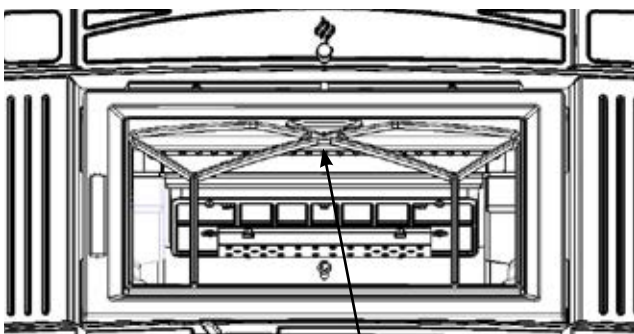

B- Combustor Flame Shield - loosen 2 x 7/16" bolts to remove.

3. Lift off bypass plate, remove bypass gasket and replace with a new one.

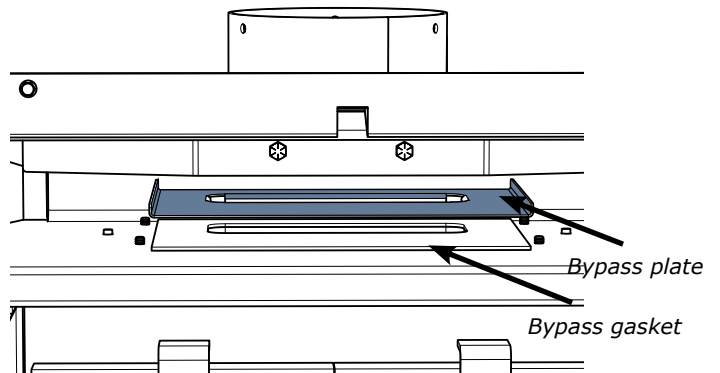

4. Reinstall bypass plate.
5. Reinstall the Upper Shield removed in Step 2d.
 Ensure Upper Shield is centered in between 2 (two) vertical pins from front to back.
 When positioning the upper shield locate the vertical pins by feel.
 When the shield parts are in place - slide to the back.

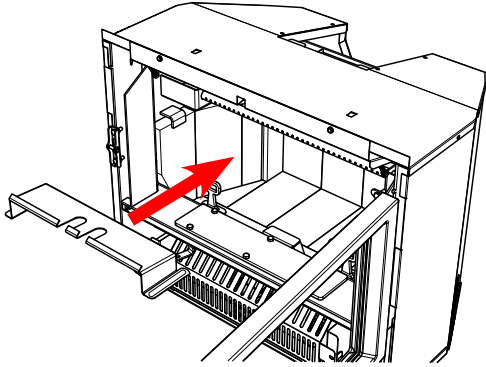

E- Upper Shield - orientation for reinstall

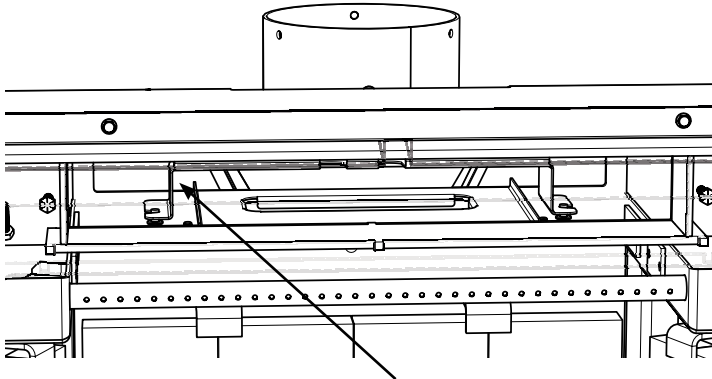

Upper Shield - center between 2 vertical pins

6. Reinstall Combustor/Flame Combustor Shield / Primary Air Shield and Bypass Rod.

DOOR GASKET

If the door gasket requires replacement, 5/8" diameter material must be used. A proper high temperature gasket adhesive is required. A gasket repair kit, Part # 846-530 is available from your local Regency dealer.



Cleaning &
 Maintaining Your
 Wood Stove

GLASS CLEANING

Only clean your glass window when it is cool. Your local retailer can supply you with special glass cleaner if plain water and a soft cloth does not remove all deposits. Regular cleaning will prevent the build up of carbon and allow full view of fire.

- CAUTION:** Do not build fire too close to glass window.
- WARNING:** Do not use abrasive cleaners.
- WARNING:** Do not clean glass when hot.
- WARNING:** Do not operate unit with broken glass

GLASS REPLACEMENT

Your Regency Insert is supplied with 5mm Neoceram ceramic glass (Part #940-420/P) that will withstand the highest heat that your unit will produce. In the event that you break your glass by impact - purchase your replacement from an authorized Regency dealer only, and follow our step-by-step instructions.

WARNING: Do not use substitute materials.

GLASS REMOVAL

Allow the stove to cool before removing or replacing glass. Remove the door from the insert and remove the glass retainer. Use caution when removing broken glass to prevent injury.

When placing the replacement glass in the door, make sure the glass gasket will properly seal your unit. Replace the retainer and tighten securely, but do not wrench down on the glass as this may cause breakage. Do not substitute materials. If your glass door does break, do not continue to use your unit until it has been replaced.

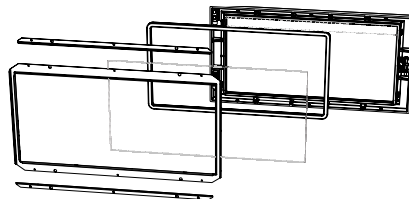

WARNING: Avoid impact on glass doors such as striking or slamming shut.

Annual Maintenance	
Completely clean out entire unit	Annually
Inspect air tubes, baffles and bricks	Replace any damaged parts.
Adjust door catch / latch	If unable to obtain a tight seal on the door - replace door gasket seal. Readjust latch after new gasket installed.
Inspect condition and seal of: Glass Gasket Door Gasket Bypass Door Gasket	Perform paper test - replace gasket if required
Paper Test	Test the seal on the loading door and bypass door with a paper bill. Place a paper bill in the gasketed area of the door on a cold stove—close the door. Try to remove the paper by pulling. The paper should not pull out easily; if it does, try adjusting the door latch (loading door only). If that doesn't solve the problem, replace the door gasket, bypass gasket, or both.
Check and lubricate door hinge + latch	Use only high temperature anti seize lube. (ie. never seize)
Check glass for cracks	Replace if required.
Clean blower motor	Disconnect power supply. Remove and clean blower. *DO NOT LUBRICATE*
Inspect and clean chimney	Annual professional chimney cleaning recommended.
Thermostat Probe	The thermostat probe that is inserted into the opening above the insert must be cleaned at least once a year. Use 220 sand paper to clean probe. Access to the probe can be done in 2 ways. - by removing the catalyst as this will be exposed once the catalyst is removed. - by removing the faceplate. However, there must be clearance above the insert to be able to remove the probe from the top of the insert. See specific details in this manual.

NOTE: Chimney Cleaning

When cleaning the chimney system the bottom stainless steel shield underneath the bypass door should be removed for ease of cleaning. The catalytic combustor should also be removed so this can also be cleaned at the same time following the guide lines found in this manual. The bypass should be moved all the way outward so any creosote will fall onto the firebox floor when being cleaned. We highly recommend that the chimney cleaning be done by a professional as they will have the necessary tools such as a proper sized brush and special vacuum cleaner designed to deal with fine particles.

IMPORTANT:

Before attempting to loosen or remove any screw, bolt from the interior of a wood stove, insert or factory built fireplace that has had a fire burned in it, we highly recommend to liberally spray the screw/bolt with a good-quality penetrating oil, one that does not have flammable properties contained within the penetrating oil being used. Allow it to set, then tap or vibrate the screw or bolt to help loosen it before attempting to remove it. For best results, follow the instructions that are provided with the penetrating oil.

SECONDARY AIR TUBE REMOVAL / INSTALLATION

1. Allow the stove to burn out and cool down, until cool to touch.
2. Open stove door to access secondary air tube.

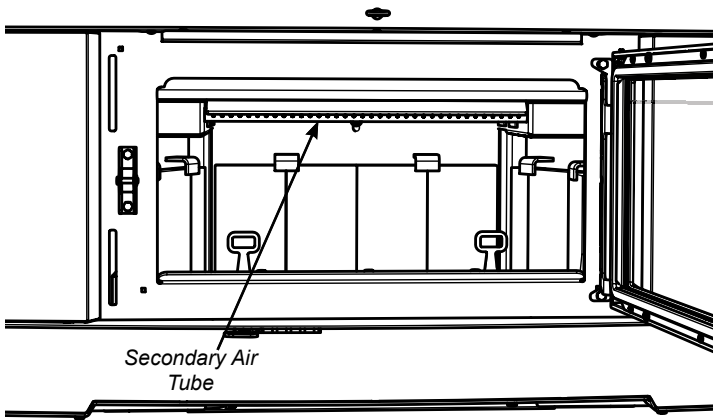

3. Grasp secondary air tube firmly with vise grips, using a hammer tap vise grips from right to left until air tube is released from grip.

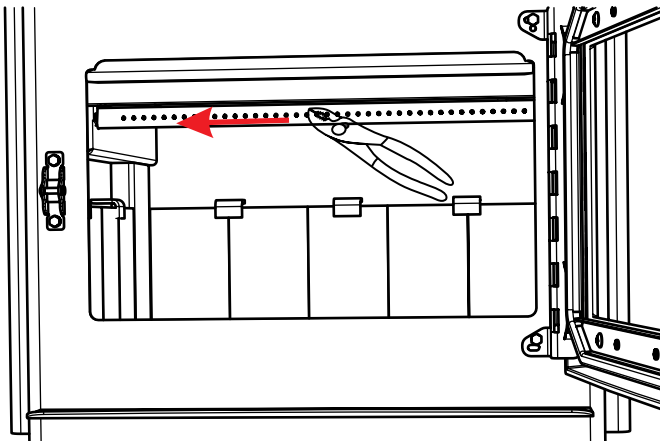

4. To reinstall or replace, first slide left side of tube into hole on left side air channel. Align tab on right side air channel with notch on right hand end of air tube. Firmly grip center of air tube with vise grips, use hammer to tap vise grips from left to right until the tube bottoms out into the air channel on right.

DOOR CATCH ADJUSTMENT

After a few fires, the door catch may require adjustment to renew a tight seal, as the door gasket will compress. Removal of a shim, shown in the diagram below, will allow the catch to be moved closer to the door frame, creating a tighter seal.

To remove a shim, loosen the 2 bolts to create clearance behind catch. Place a screwdriver in the slot of the shim and slide out. Retighten bolts. Note: Keep the shims - they may be required in the future when the gasket is replaced.

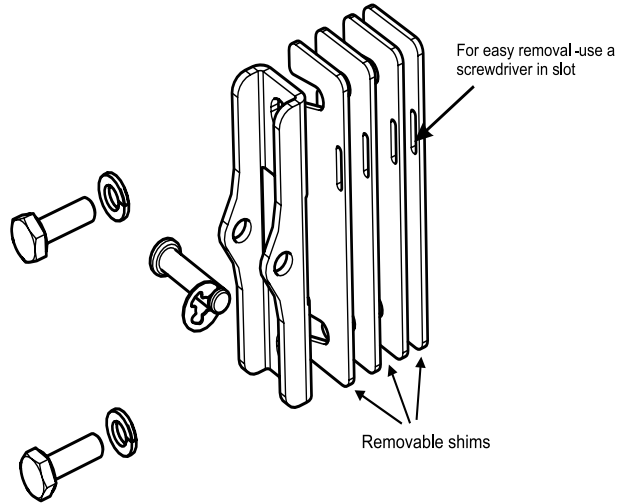

CAST BYPASS TOP PLATE REMOVAL / INSTALLATION

1. Allow the stove to burn out and cool down, until cool to touch.
2. Open stove door to access secondary air tube.
3. Remove secondary air tube—(see previous page).
4. Remove 2 bolts in locations shown and remove stainless steel front lip retainer.

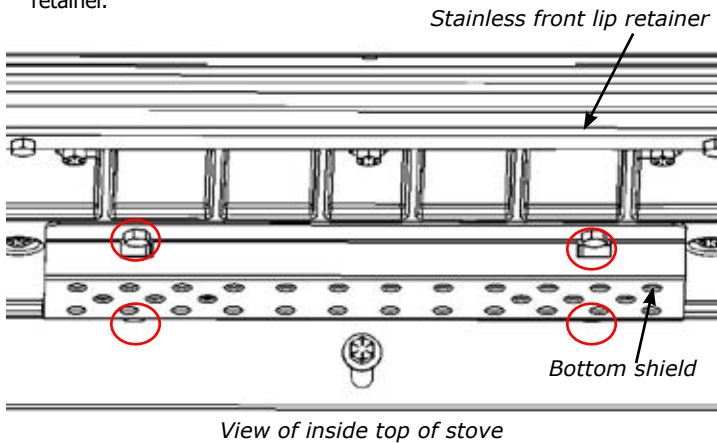

5. Loosen the 4 bolts holding the bottom shield. Slide shield towards door opening to remove.
6. 8 bolts secure the cast bypass top plate to the roof of the stove. Before removing the bolts securing the cast bypass - support the cast up with 2 X 12-1/4" 2 x 4 's. The cast bypass opening weighs 30lbs - **DO NOT REMOVE** the bolts on the cast bypass prior to supporting the weight to avoid damage and injury.

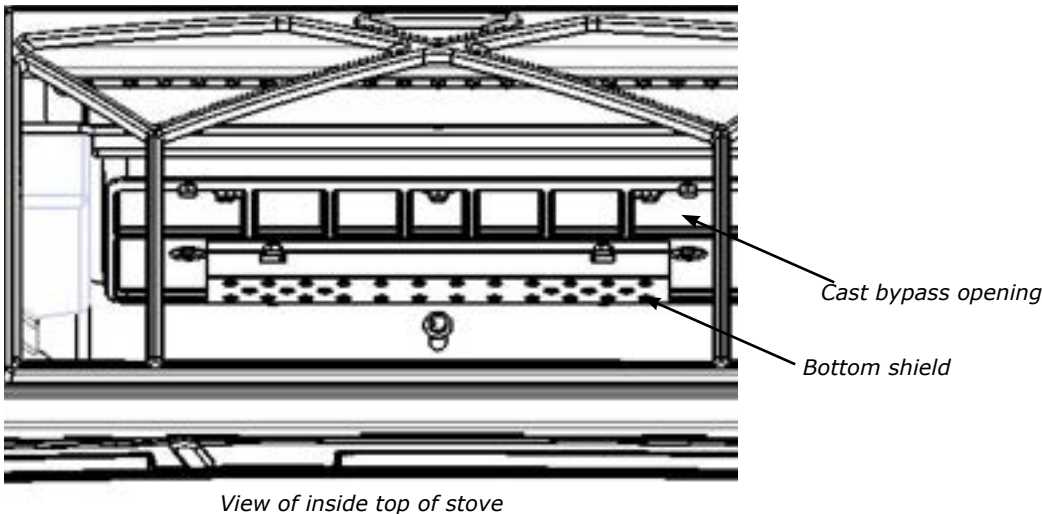

7. Remove the cast bypass opening top plate and replace.
8. Reverse steps to reinstall.

FAN OPERATION INTO AUTO MODE

If fan will not come on in auto mode see the following possible causes and solutions:

Possible causes:

- Bypass damper is open
- Brand new unit or first burn of the season
- No ember bed established (embers or coals, not to be mistaken with ashes)
- Primary damper is set to low (all the way to the right)
- There are only a couple small logs on fire or fire is almost out
- Mechanical issues or defects

Solutions:

- Close bypass once unit is at optimum temperature
- Establish a couple inch ember bed
- Set damper between medium to high (middle or all the way to the left)
- Add a few more logs onto the fire
- See your authorized dealer

NOTE: The temperature displayed on the catalyst monitor has nothing to do with the activation temperature in auto for the fan.

The automatic sensor for this appliance is located at the firebox base. If the temperature at this location is not met, the fan will not come on. It is crucial on this appliance to get this up to operating temperature so that the catalyst is activated and bypass may be closed to retain heat within the firebox.

SWEEPING THE FLUE FROM THE TOP DOWN

Note: The chimney system on this appliance cannot be cleaned from below.

IMPORTANT: It is imperative that the area around the exterior of the fireplace insert is protected with blankets, drop clothes to prevent any creosote, ash from falling on the finished floor.

1. Remove the primary air shield

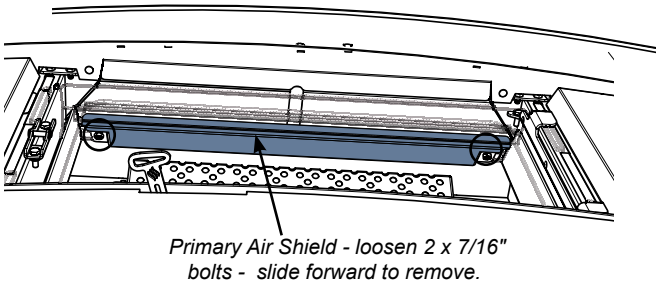

2. Remove the combustor flame shield.

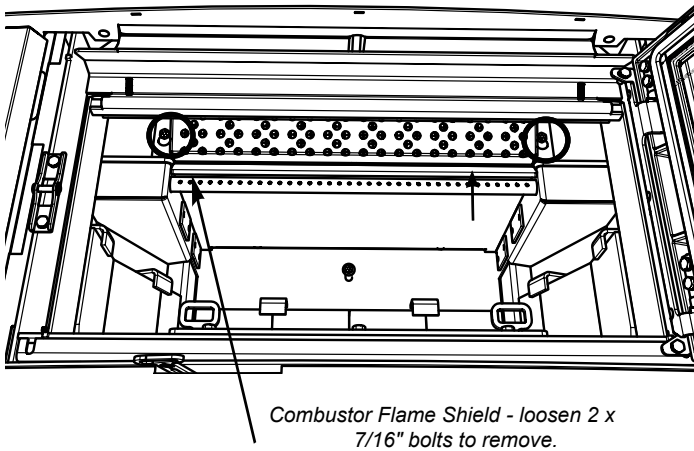

3. Remove the catalyst combustor

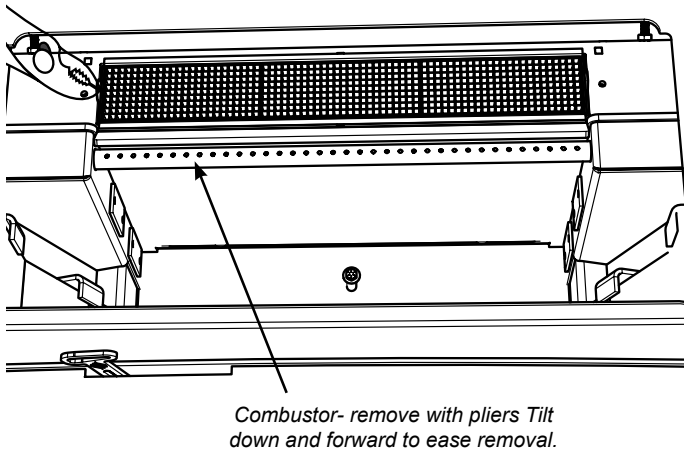

4. Close the door of the insert and the bypass rod and sweep the flue from the top of the chimney down into the bypass area.

5. After allowing the debris to settle slowly open the door to prevent spillage. Using an ash vac and extensions clean the area behind the catalyst combustor and bypass area.

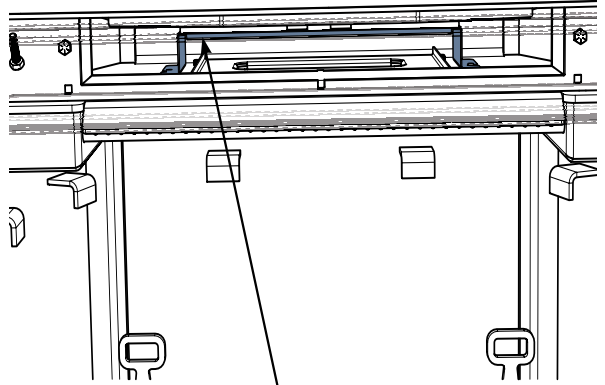

6. Check that the bypass is moving freely after cleaning the area. Do additional cleaning and make adjustments as needed.

7. Reverse steps 1-3 to reinstall the combustor, combustor flame shield and primary air shield.

MAIN ASSEMBLY

	Part #	Description
2	106-517	Stove Top Assembly
3	106-917	Fan Assembly
4	106-525	Rear Panel Assembly
5	106-038	Outer Shield L
6	106-520	Black cast door Assembly
*	106-565	Timberline Brown cast door Assembly
7	106-039	Outer Shield R
8	106-518	Handle/Tool Holder Assembly Regular
*	106-542	Handle/Tool Holder Assembly Oversize
9	106-912	Contemporary Faceplate
*	106-910	Low Profile Faceplate
*	106-921	Cast Faceplate Regular - Black
*	106-925	Cast Faceplate Regular -Timberline Brown
*	106-941	Cast Faceplate - Oversize Black
*	106-945	Cast Faceplate - Oversize Timberline Brown
*	106-931	Cast Grill - Black
*	106-935	Cast Grill - Timberline Brown
*	106-956	Standard Backing Plate
*	106-958	Oversize Backing Plate
10	156-241	Cast Handle
11	156-514	Handle Assembly
*	106-541/P	Aligner Assembly (For Back Side of Door Latch)
12	106-561	Catch Assembly
*	106-131F	106-131F Door Catch Shims (Each)
13	106-043	Andirons (ea)
13A	106-042	Andiron Bracket (Each)
14	106-016	Bypass rod
15	106-122B	Bypass knob (Matt Black)
	106-122MJE	Bypass knob (Timberline brown)
19	106-143	Bottom shield

	Part #	Description
16	106-516	Flue Collar Assembly
17	106-062F	Fork
20	106-534	Catalytic Combustor
*	106-546	Contemporary Rail Assembly Left
*	106-547	Contemporary Rail Assembly Right
*	911-185	Digital Catalytic Combustor Monitor
24	911-186	Digital Catalytic Monitor Probe
*	106-955	Offset Flue Adapter
26	106-351	Cast Bypass Top Plate
27	106-018	Bypass Top Gasket
*	910-138	Auto/manual switch
*	910-140	Fan Hi/Off/Low switch
	106-536	Fan Swith Assembly Complete
*	910-142	Fan Thermodisc
*	910-157/P	Fan motor only
*	940-420/P	Replacement Glass (Includes Glass Gasket)
*	846-682	7/8" Window Adhesive Gasket Tape (12') (936-243)
*	106-003	Stainless steel baffle
29	106-095	Primary Air Shield
30	106-144	Combustor Flame Shield
*	106-060	Upper Shield
*	106-129	Bypass Damper Tool
34	033-953	Secondary Air Tube
35	106-133	Door Hinge Basket
*	106-020	Gasket Firebox Floor
	920-047	Manual
*Part not Shown		

42 | parts list

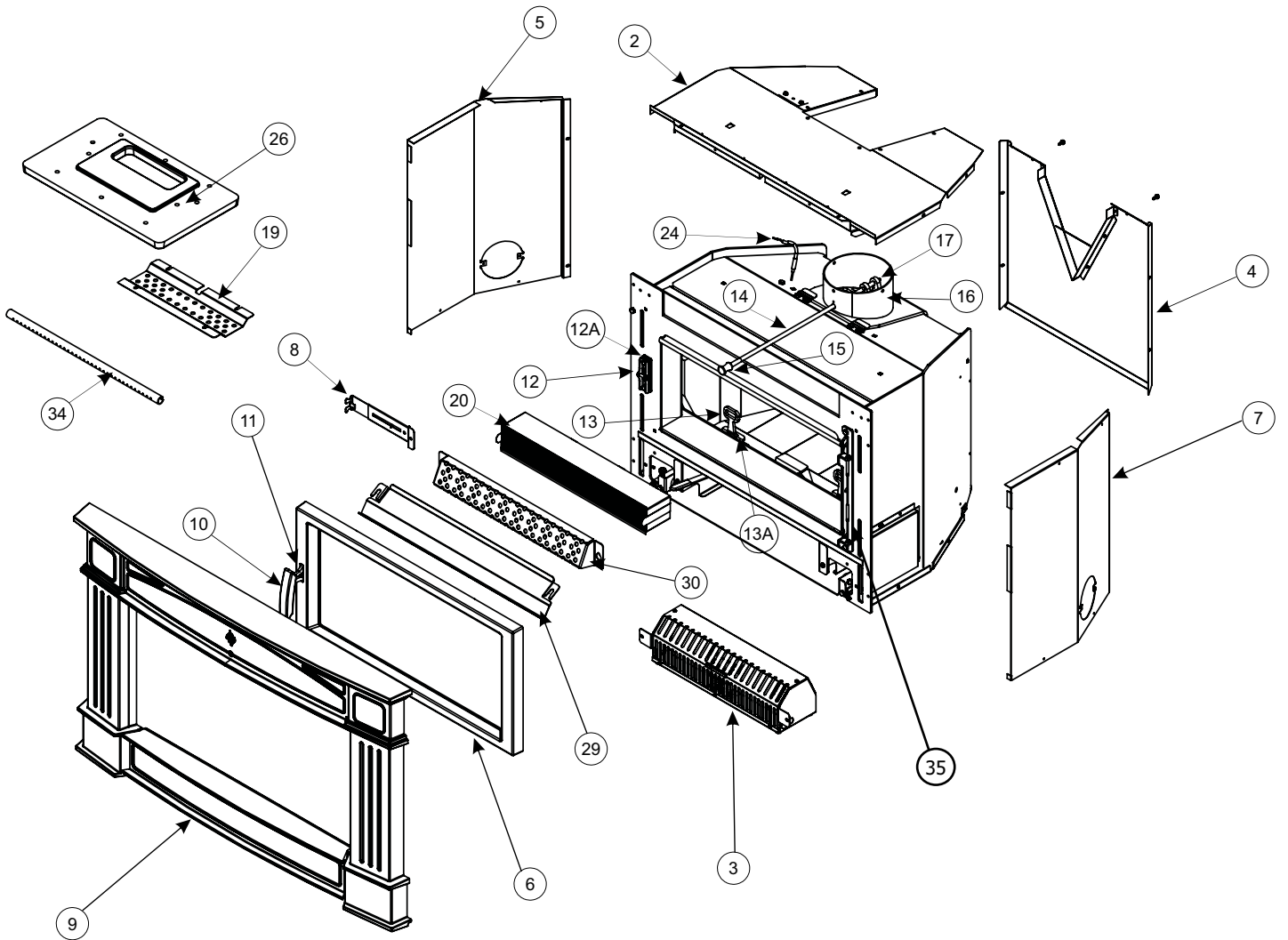

BRICK LAYOUT

106-960 Brick Set - Complete

Fire bricks		
#	Size	Quantity
1	4-1/2" x 9" Standard Brick	10
2	Fire Brick	2
3	Fire Brick	2
4	2" x 9" Brick	4
5	2" x 7" Brick	1

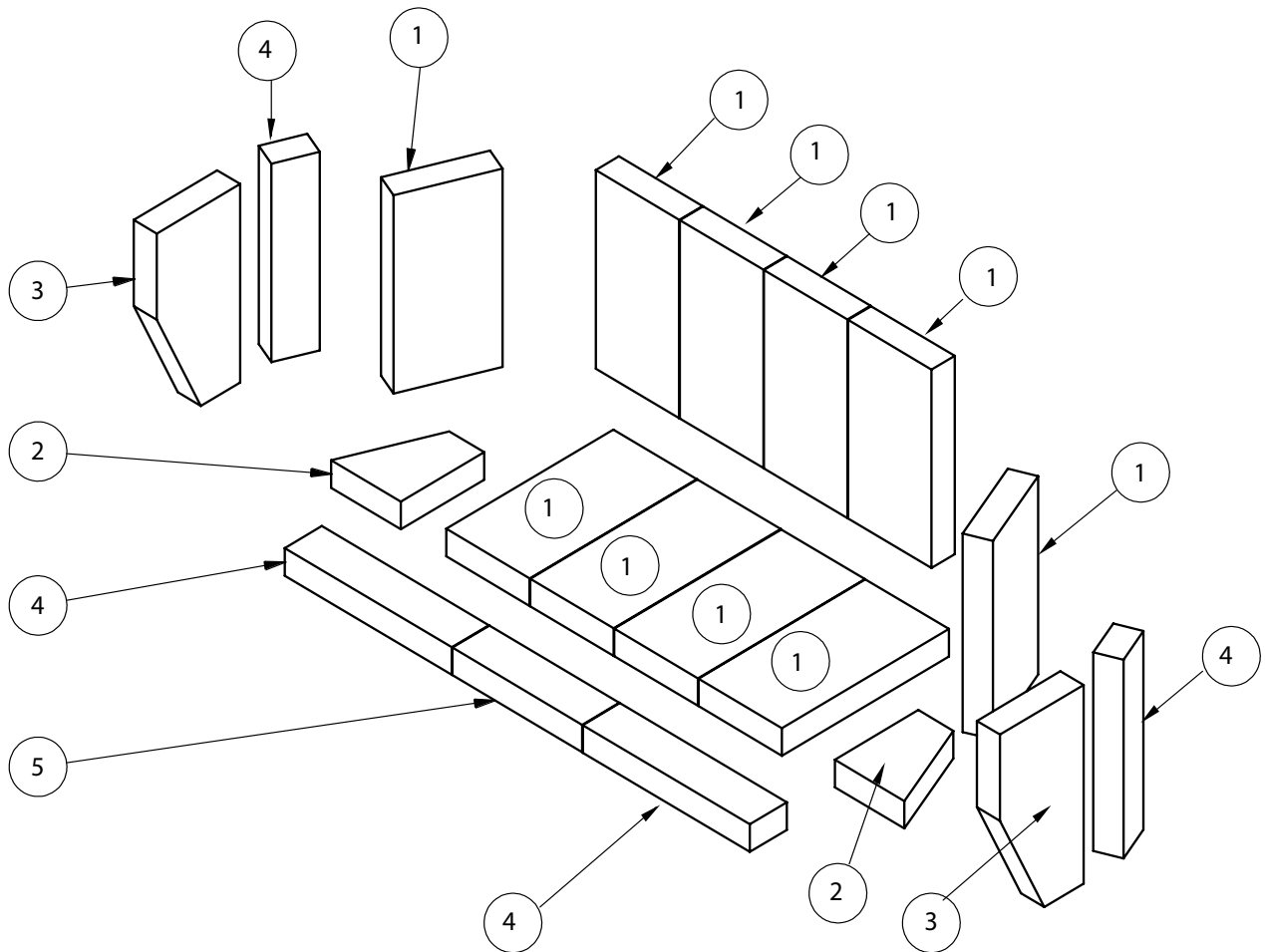

Indoor Wood Product Warranty

Limited Lifetime Warranty

FPI Fireplace Products International Ltd. (for Canadian customers) and Fireplace Products U S, Inc. (for US customers) (collectively referred to herein as "FPI") extends this Limited Lifetime Warranty to the original purchaser of this Appliance provided the product remains in the original place of installation. The items covered by this Limited Lifetime Warranty and the period of such coverage are set forth in the table below.

An Appliance in this policy is defined as an Indoor wood insert or Indoor wood freestanding stove.

This Appliance has only been certified and listed for use indoors.

Note: This Wood Product Warranty does not apply to the Ri50 & CF780 models. See Ri50/CF780 policy for specific warranty details.

This Limited Lifetime Warranty starts on the day the Appliance was purchased.

The Limited Lifetime Warranty is not transferable, amendable or negotiable under any circumstances.

Indoor Wood Products	Component Coverage					Subsidized Labor Coverage*** (Years)
	Limited Lifetime	5 years	2 years	1 year	Warranty	
Components Covered						
Welded Firebox Steel	✓					5
All Stainless Steel Components, Smoke Deflectors, Heat Shields etc.	✓					3
Air Tubes	✓					3
Airmate	✓					3
Door handle and latch assembly, all hardware	✓					3
Glass Thermal Breakage Only	✓					3
Steel Faceplates, Accessory Housings	✓					3
All Plating	✓					3
Ash Drawer, Heatshields, Pedestal	✓					0
All Baffles, Steel, Ceramic, Vermiculite C-Baffles	✓					0
All castings, firebox, surrounds, doors, panels etc.		✓				3
All Electrical, Blower, wiring, switches, Catalytic Monitors, Probes, etc.			✓			2
Glass - Crazing				✓		1
Catalyst Combustor					**10 Years Prorated	0
Venting/Chimney				✓		1
Screens				✓		1

**See specific warranty details regarding the catalyst combustor in this manual.

Note: Warranty coverage noted above may not be applicable as components/options vary based on appliance purchased.

Conditions:

Warranty protects against defect in manufacture or FPI factory-assembled components only, unless herein specified otherwise.

*****This warranty does not cover dealer travel costs, mileage, fuel, tolls for diagnostic or service work. All labor rates paid to authorized dealers are subsidized, pre-determined rates. Dealers may charge you for travel and additional time beyond their subsidy.**

Any part(s) found to be defective during the warranty period as outlined above will be repaired or replaced at FPI's option through an accredited distributor, dealer or pre-approved and assigned agent provided that the defective part is returned to the distributor, dealer or agent for inspection if requested by FPI. Alternatively, FPI may, at its own discretion, fully discharge all of its obligations under warranty by refunding the verified purchase price of the product to the original purchaser. The purchase price must be confirmed by the original Bill of Sale.

The authorized selling dealer, or an alternative authorized FPI dealer if pre-approved by FPI, is responsible for all in-field diagnosis and service work related to all warranty claims. FPI is not responsible for results or costs of workmanship of unauthorized FPI dealers or agents in the negligence of their service work.

At all times, FPI reserves the right to inspect reported in the field/on location complaints of products claimed to be defective before processing or authorizing any claim. Failure to allow this upon request will void the warranty.

All warranty claims must be submitted by the dealer servicing the claim, including a copy of the Bill of Sale (proof of purchase by you). All claims must be complete and provide full details as requested by FPI to receive consideration for evaluation. **Incomplete claims may be rejected.**

Replacement Appliances to the original purchaser are limited to one per warranty term. Air tube and baffle replacements are limited to one replacement per warranty term.

The Appliance must be installed according to all manufacturers' instructions as per the manual. All Local and National required codes must be met.

The installer is responsible for ensuring the Appliance is operating as designed at the time of installation.

The original purchaser is responsible for the annual maintenance of the Appliance, as outlined in the owner's manual. As outlined below, the warranty may be voided due to problems caused by a lack of maintenance.

Purchased parts: Repair/replacement parts purchased by the consumer from FPI after the original coverage has expired on the Appliance will carry a **90-day** warranty from the purchase date, valid with a receipt only. Any item shown to be defective will be repaired or replaced at our discretion. No labor coverage is included with these parts.

If freight damage has been found either externally or internally, the dealer must be informed within 3 days. All claims as a result of damage must be submitted by the dealer servicing the claim, including a copy of the Bill of Sale (proof of purchase). All claims must be complete and provide full details as requested by FPI to receive consideration for evaluation. **Incomplete claims may be rejected.**

As this is a Limited Lifetime Warranty, if the Appliance needs to be replaced, the Appliance that was purchased at the time of sale might not be replaced with exactly the same model Appliance. In that case, FPI will replace your Appliance with one that is similar at the time of replacement under the terms of this Limited Lifetime Warranty, but **ONLY** in the event that an item covered by the Limited Lifetime Warranty is found to be defective. Please refer to the table on first page of this warranty for items covered by the Limited Lifetime Warranty. Product changes might be the result of the original Appliance being discontinued, changes in regulatory requirements, product advancements, etc., which are beyond the control of FPI. **This Limited Lifetime Warranty does not cover any installation costs, or costs associated with changes of required clearances for the replacement Appliance, hearth pads, mantles, facing and/or facing materials such as framing, completed walls made of drywall, wood, non-combustible board, tile, brick, stone, marble etc., venting/chimney systems, or components of the chimney system.**

If a suitable replacement is not available, FPI will refund **50%** of the purchase price of the Appliance and any applicable FPI accessories (faceplates, brick panels, media, etc.) purchased at the time of sale. **In no event will FPI refund any portion of the purchase price of, or reimburse costs associated with, any other items, including without limitation, installation of a new unit, changes of required clearances for a new unit, hearth pads, mantles, facing and/or facing materials such as framing, completed walls made of drywall, wood, non-combustible board, tile, brick, stone, marble etc., venting/chimney systems, or components of the chimney system. A copy of the receipt or bill of sale will be necessary to validate the purchase price.**

Exclusions:

This Limited Lifetime Warranty does not extend to paint, rust or corrosion of any kind due to a lack of maintenance or improper venting, combustion air provision, corrosive chemicals (i.e. chlorine, salt, air, etc.), firebrick (rear, sides or bottom), door or glass gasketing, vermiculite floor bricks, and iron assemblies/flue damper rod or any other additional factory fitted gasketing, batteries.

Malfunction, damage or performance-based issues as a result of environmental conditions, location, chemical damages, downdrafts, installation error, an installation by an unqualified installer, incorrect chimney components (including but not limited to cap size or type), operator error, abuse, misuse, use of improper fuels (such as unseasoned cordwood, mill-ends, construction lumber or debris, off-cuts, treated or painted lumber, metal or foil, plastics, garbage, solvents, cardboard, coal or coal products, oil-based products, waxed cartons, compressed pre-manufactured logs, kiln dried wood), lack of regular maintenance and upkeep, acts of God, weather-related problems from hurricanes, tornados, earthquakes, floods, lightning strikes/bolts or acts of terrorism or war, which result in a malfunction of the Appliance are not covered under the terms of this Limited Lifetime Warranty.

46 | warranty

FPI has no obligation to enhance or modify any Appliance once manufactured (i.e. as products evolve, field modifications or upgrades will not be performed on existing Appliances).

Any Appliance showing signs of neglect or misuse will not be covered under the terms of this warranty policy and may void this warranty, including Appliances with rusted or corroded fireboxes that have not been reported as rusted or corroded within **three (3)** months of installation/purchase.

Appliances which show evidence of being operated while damaged, or with problems known to the purchaser and causing further damages will void this warranty.

Appliances where the serial no. has been altered, deleted, removed or made illegible will void this warranty.

Minor movement, expansion and contraction of the steel is normal and is not covered under the terms of this warranty.

Freight damages for products or parts are not covered under the terms of the warranty.

Products made or provided by other manufacturers and used in conjunction with the FPI Appliance without prior authorization from FPI may void this warranty.

Limitations of Liability:

The original purchaser's exclusive remedy under this warranty, and FPI's sole obligation under this Limited Lifetime Warranty, express or implied, in contract or in tort, shall be limited to replacement, repair, or refund, as outlined above. IN NO EVENT WILL FPI BE LIABLE UNDER THIS WARRANTY FOR ANY INCIDENTAL OR CONSEQUENTIAL COMMERCIAL DAMAGES OR DAMAGES TO PROPERTY. TO THE EXTENT PERMITTED BY APPLICABLE LAW, FPI MAKES NO EXPRESS WARRANTIES OTHER THAN THE WARRANTY SPECIFIED HEREIN. THE DURATION OF ANY IMPLIED WARRANTY IS LIMITED TO DURATION OF THE EXPRESSED WARRANTY SPECIFIED ABOVE. IF IMPLIED WARRANTIES CANNOT BE DISCLAIMED, THEN SUCH WARRANTIES ARE LIMITED IN DURATION TO THE DURATION OF THIS WARRANTY.

Some US states do not allow limitations on how long an implied warranty lasts, or allow exclusion or limitation of incidental or consequential damages, so the above limitations or exclusions may not apply to you.

Customers located outside the US should consult their local, provincial or national legal codes for additional terms, which may be applicable to this warranty.

How to Obtain Warranty Service:

Customers should contact the authorized selling dealer to obtain warranty service. In the event the authorized selling dealer is unable to provide warranty service, please contact FPI by mail at the address listed below. Please include a brief description of the problem and your address, email and telephone contact information. A representative will contact you to make arrangements for an inspection and/or warranty service.

Canadian Warrantor:

FPI Fireplace Products International Ltd.
6988 Venture St.
Delta, British
Columbia Canada,
V4G 1H4

US Warrantor:

Fireplace Products U.S., Inc.
PO Box 2189 PMB 125
Blaine, WA
United States, 98231

Or contact the Regency Customer Care Centre at 1-800-442-7432 (phone) /604-946-4349 (fax) /customerservice@regency-fire.com (e-mail)

Product Registration and Customer Support:

Thank you for choosing a Regency Fireplace. Regency strives to be a world leader in the design, manufacture, and marketing of hearth products. To provide the best support for your product, we request that you complete a product registration form at <http://www.regency-fire.com/Customer-Care/Warranty-Registration.aspx> within **ninety (90)** days of purchase.

Warranty Registration Card



Product Registration and Customer Support:

Thank you for choosing a Regency Fireplace. Regency strives to be a world leader in the design, manufacture, and marketing of hearth products. To provide the best support for your product, we request that you complete a product registration form found on our Web Site under Customer Care within ninety (90) days of purchase.

For purchases made in **CANADA or the UNITED STATES:**

<http://www.regency-fire.com/Customer-Care/Warranty-Registration.aspx>

For purchases made in **AUSTRALIA:**

<http://www.regency-fire.com.au/Customer-Care/Warranty-Registration.aspx>

You may also complete the warranty registration form below to register your Regency Fireplace Product and mail and/or fax it back to us, and we will register the warranty for you. It is important you provide us with all the information below in order for us to serve you better.

Warranty Registration Form (or Register online immediately at the above Web Site):

Warranty Details	
Serial Number (required):	
Purchase Date (required) (mm/dd/yyyy):	
Product Details	
Product Model (required):	
Dealer Details	
Dealer Name (required):	
Dealer Address:	
Dealer Phone #:	
Installer:	
Date Installed (mm/dd/yyyy):	
Your Contact Details (required)	
Name:	
Address:	
Phone:	
Email:	

For purchases made in **CANADA:**

FPI Fireplace Products International Ltd.
6988 Venture St.
Delta, British Columbia
Canada, V4G 1H4

Phone: 604-946-5155
Fax: 1-866-393-2806

For purchases made in **the UNITED STATES:**

Fireplace Products US, Inc.
PO Box 2189 PMB 125
Blaine, WA
United States, 98231

Phone: 604-946-5155
Fax: 1-866-393-2806

For purchases made in **AUSTRALIA:**

Fireplace Products Australia Pty Ltd
99 Colemans Road
Dandenong South, Vic.
Australia, 3175

Phone: +61 3 9799 7277
Fax: +61 3 9799 7822

For fireplace care and tips and answers to most common questions please visit our Customer Care section on our Web Site. Please feel free to contact your selling dealer if you have any questions about your Regency product.

CATALYTIC COMBUSTOR PARTS ONLY WARRANTY COVERAGE

IMPORTANT WARRANTY INFORMATION FOR CATALYTIC COMBUSTOR

Effective March 1, 2019

Any and all claims for catalytic combustor must be filed by the consumer directly with their authorized Regency Dealer. FPI/Regency does not handle these claims directly with consumers.

Please follow the instructions below for your catalytic combustor under warranty. To learn more about the care and maintenance or the catalytic combustor, please visit our website: www.firecatcombustors.com.

Any warranty coverage before this date will be covered by the original warranty when the appliance was purchased.

- (1) **10-year** coverage from Regency – not the supplier of the catalytic combustor.
- (2) All claims must be made through the dealer where the appliance had been purchased.
- (3) One no-charge replacement at any time within the **ten (10) year** period.
- (4) Second replacement at 50% off retail* within the original **ten (10) years**.
- (5) Subsequent replacements or if **ten (10)-year** coverage has expired at full retail* price.
- (6) The catalytic combustor must not have been mechanically abused, nor must the wrong fuels have been used in the appliance.
- (7) All claims must be accompanied by clear photos of the catalytic combustor showing all damage and also showing existing internal venting from the stove.

The consumer will be responsible for removal of the catalyst and any servicing required as there is no labour allowance. This warranty is REGENCY[®] exclusive warranty and REGENCY[®] disclaims any other express or implied warranty for the catalytic combustor, including any warranty or merchantability of fitness for a particular use.

THE CATALYTIC COMBUSTOR WARRANTY APPLIES TO PARTS ONLY, THERE IS NO LABOR WARRANTY ASSOCIATED WITH THE CATALYTIC COMBUSTOR.

All warranty claims must be sent to: Regency Fireplace Products

By Authorized Regency Dealer

Installer: Please complete the following information

Dealer Name & Address: _____

Installer: _____

Phone #: _____

Date Installed: _____

Serial #: _____