



ULTIMATE™ U38E Freestanding Gas Stove

Owners & Installation Manual



U38-39 Video

www.regency-fire.com

MODELS: U38E-NG11 Natural Gas U38E-LP11 Propane

⚠ WARNING

FIRE OR EXPLOSION HAZARD

Failure to follow safety warnings exactly could result in serious injury, death, or property damage.

- Do not store or use gasoline or other flammable vapors and liquids in the vicinity of this or any other appliance.
- **WHAT TO DO IF YOU SMELL GAS**
 - Do not try to light any appliance.
 - Do not touch any electrical switch: do not use any phone in your building. Leave the building immediately.
 - Immediately call your gas supplier from a neighbour's phone. Follow the gas supplier's instructions.
 - If you cannot reach you gas supplier, call the fire department.
- Installation and service must be performed by a qualified installer, service agency or the gas supplier.

Tested by:



Certified to/Certifié pour:
CSA/ANSI Z21.88:19
CSA 2.33:19
CSA 2.17-2017

Installer: Please complete the details on the back cover and leave this manual with the homeowner.
Homeowner: Please keep these instructions for future reference.

To the New Owner:

Congratulations! You are the owner of a state-of-the-art ULTIMATE Gas Stove by FIREPLACE PRODUCTS INTERNATIONAL LTD. The Regency® Gas Series of hand crafted appliances has been designed to provide you with all the warmth and charm of a woodstove, at the flick of a switch. The models U38E-NG11, and U38E-LP11 of this series has been approved by Warnock Hersey/Intertek for both safety and efficiency. As it also bears our own mark, it promises to provide you with economy, comfort and security for many trouble free years to follow. Please take a moment now to acquaint yourself with these instructions and the many features of your Regency® Gas Stove.



DANGER

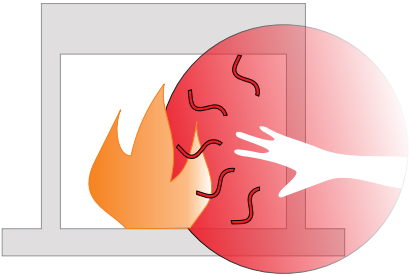

**HOT GLASS WILL
CAUSE BURNS**

**DO NOT TOUCH GLASS
UNTIL COOLED**

**NEVER ALLOW CHILDREN
TO TOUCH GLASS**

A barrier designed to reduce the risk of burns from the hot viewing glass is provided with this appliance and must be installed for the protection of children and other at risk individuals.

CAUTION:
HOT WHILE IN OPERATION. DO NOT TOUCH.
SEVERE BURNS MAY RESULT. KEEP CHILDREN, CLOTHING, FURNITURE,
GASOLINE, AND ANY OTHER LIQUIDS WITH FLAMMABLE VAPOURS AWAY.

**KEEP BURNER AND CONTROL COMPARTMENT CLEAN.
SEE INSTALLATION AND OPERATING INSTRUCTIONS ACCOMPANYING
APPLIANCE.**

920-408



**NATIONAL
FIREPLACE
INSTITUTE**
CERTIFIED
www.nficertified.org

We recommend that our products be installed and serviced by professionals who are certified in the U.S. by the National Fireplace Institute® (NFI) or in Canada by Wood Energy Technical Training (WETT).



This appliance may only be installed in an aftermarket permanently located, manufactured (USA only) or mobile home, where not prohibited by local codes.

This appliance is only for use with the type of gas indicated on the rating plate. This appliance is not convertible for use with other gases, unless a certified kit is used.



U38-39 Video

owner's information

Safety Label for the U38E-11.....	5
Gas Installation CHecklist.....	6
Before You Start.....	8
Lighting Procedure	9
Shutdown Procedure	9
Copy of the Lighting Plate Instructions.....	10
Proflame II Remote Control Operating Instructions	11

Warranty

Warranty	42
----------------	----

installer's information

Dimensions

Dimensions	4
------------------	---

Installation

PRoflame II Battery Holder Battery Replacement & Battery Back Up.....	15
Important Message	17
General Safety Information	17
Installation Checklist.....	17
Clearances to Combustibles.....	18
U38E-NG11 & U38E-LP11 Clearances.....	18
U38E-NG11 & U38E-LP11 Reference Dimensions	18
Optional Outside Air	18
Outside Air Through Pedestal Bottom.....	18
Outside Air Through Rear of Pedestal.....	18
Draft Hood.....	19
High Elevation.....	19
Venting.....	19
Flue Mounting Bracket	19
Gas Connection.....	20
System Data	20
Gas Pipe Pressure Testing	20
885 S.I.T. Valve Description.....	20

On Demand Pilot Light.....	20
Conversion Kit# 753-977 from NG to LP.....	21
Conversion to Lower BTU Rating	22
Log Set Installation	23
Driftwood Log Set Installation	26
Front Door Installation.....	29
Louver Installation.....	29
Test for Flue Spillage	29
Optional Wall Thermostat	29
Wiring Diagram without Thermostat	30
Wiring Diagram with Optional Thermostat.....	31

Operating Instructions

Battery Backup.....	32
First Fire.....	33
Operating Instructions	33
Optional Wall Thermostat.....	33
Operation using an Optional Wall Thermostat.....	33
Normal Operating Sounds of Gas Appliances	34

Maintenance

Maintenance Instructions.....	34
Aeration Adjustment.....	35
Maintenance Instructions.....	36
Log Replacement	36
Door and Glass Gasket.....	36
Glass Replacement	36
Panel Door.....	36
Fan Maintenance	36
Valve Replacement	37
Gas Maintenance.....	38

Parts

U38E-11 Main Assembly	39
U38E-11 Burner & Log Assembly	40
U38E-11 Door Assembly	41

Warranty

Warranty	44
----------------	----

On Demand Pilot (seven day safety timer)

Important information if using the appliance in CPI (continuous pilot mode) only

This appliance is a ProFlame 2 system fitted with the "On Demand" Pilot, a safety feature which will shut down the gas valve completely by extinguishing the pilot light in the event of a continuous full seven days of inactivity.

This only applies if the CPI (continuous pilot) switch is in the "on" position in your remote control transmitter.

Each time the main burner shuts down, manually or through the call from the thermostat, the seven day timer starts again.

The seven day inactivity timer is controlled within the circuit board. Therefore, if in CPI mode and when the pilot light is extinguished after seven straight days of inactivity, the CPI setting on the remote control transmitter will remain in the "CPI" (continuous pilot) position. Therefore, all that is required to relight the pilot would be to press the on/off button on the remote control transmitter from "on" to "off" and back to "on". Once the pilot has re-established operation will resume as normal. There is no requirement to do anything with the IPI/CPI mode on the remote control transmitter.

If the unit never goes as long as seven full days without a call for heat, the pilot will remain lit until it is manually shut-off.

If the unit is being operated in IPI (intermittent pilot) mode, neither the above instructions nor the seven day timer will apply.

See the instructions in this manual and on the Lighting Instructions plate on the appliance to light or re-light the pilot.

dimensions

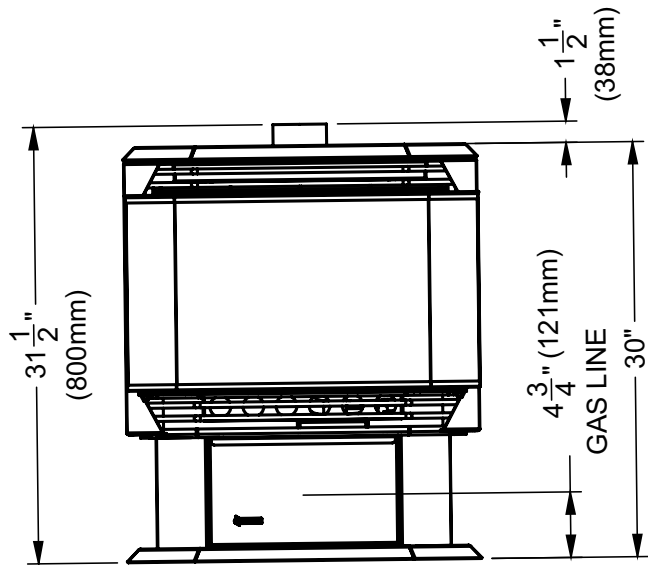
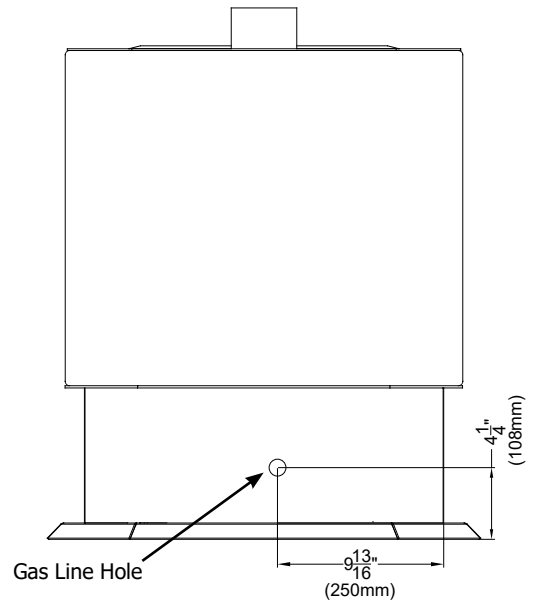
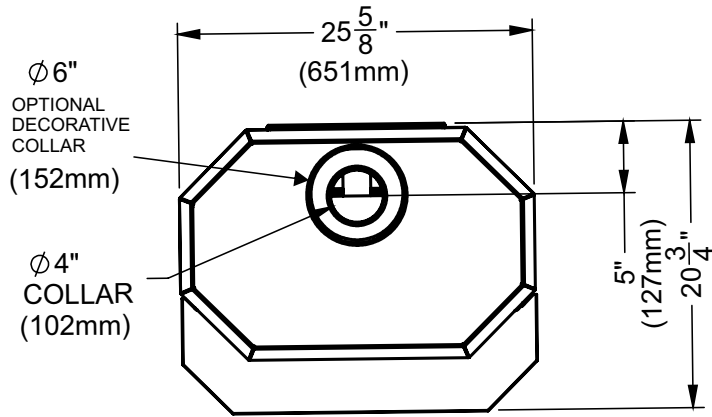

ALL PICTURES / DIAGRAMS SHOWN THROUGHOUT THIS MANUAL ARE FOR ILLUSTRATION PURPOSES ONLY. ACTUAL PRODUCT MAY VARY DUE TO PRODUCT ENHANCEMENTS.

This is a copy of the label that accompanies each ULTIMATE Freestanding Gas Stove. We have printed a copy of the contents here for your review. The safety label is located on the inside of the drop down pedestal door.

NOTE: Regency® units are constantly being improved. Check the label on the unit and if there is a difference, the label on the unit is the correct one.

Safety Label for the U38E-11

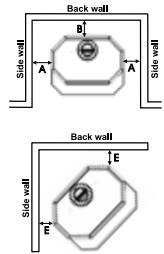
Duplicate serial #		497
<p>DO NOT REMOVE THIS LABEL / NE PAS ENLEVER CETTE ÉTIQUETTE</p> <p style="font-size: 2em; font-weight: bold; color: red;">497</p>		
<p>Intertek Serial No./No de série</p> <p>CS-4091172</p>		
<p>Listed: VENTED GAS FIREPLACE HEATER / FOYER AU GAZ À ÉVACUATION Certified to/Certifié : CSA/ANSI Z21.88:19 / CSA 2.33:19 / CSA 2.17:2017 MAY BE INSTALLED IN MANUFACTURED (MOBILE) HOMES AFTER FIRST SALE Refer to Intertek's Directory of Building Products for detailed information. Pour plus de détails, se reporter au Répertoire des produits de construction de Intertek.</p>		
<p>FACTORY EQUIPPED FOR NATURAL GAS: Modèle U38E-NG11</p> <p>Minimum supply pressure 5" WC/C.E. (1.24kPa) Manifold pressure High 3.5" WC/C.E. (0.87kPa) Manifold pressure Low 1.6" WC/C.E. (0.40kPa) Model U38E-NG11: Factory Equipped for Altitude 0-2000 ft. Orifice size #32 DMS Altitude 0-2000 ft/pi (0-610) Maximum Input 38,000 Btu/h (11.14Kwh) Minimum Input 26,000 Btu/h (7.62Kwh)</p> <p>Model U38E-NG11: Convertible for Altitude 2000-4500 ft. Orifice size #33 DMS Altitude 2000-4500ft/pi (610-1370m) Maximum Input 35,000 Btu/h (10.26Kw) Minimum Input 24,000 Btu/h (7.03Kwh)</p> <p>Model U38E-NG11: Convertible to 30,000 Btu for Altitude 0-4500 ft. Orifice size #37 DMS Maximum Input 30,000 Btu/h (8.78Kwh) Minimum Input 21,000 Btu/h (6.15Kwh)</p>	<p>APPAREIL FONCTIONNANT AU GAZ NATUREL : Modèle U38E-NG11</p> <p>Pression d'alimentation minimale Pression manifold élevée Pression manifold basse Modèle U38E-NG11 conçu pour altitude 0-2000 pi Dimensions de l'orifice Altitude Débit calorifique maximal Débit calorifique minimal</p> <p>Modèle U38E-NG11 convertible pour altitude 2000-4500 pi Dimensions de l'orifice Altitude Débit calorifique maximal Débit calorifique minimal</p> <p>Modèle U38E-NG11 convertible à 30 000 btu pour altitude 0-4500 pi Dimensions de l'orifice Altitude Débit calorifique maximal Débit calorifique minimal</p>	<p>Minimum Clearances to Combustibles Dégagements minimaux aux matériaux combustibles</p> <p>A 7-1/2" /150mm B 6" /150mm E 2" /50mm Min. Ceiling Height from top of unit / Hteur min. de plafond à partir du haut de l'appareil : 36" / 914 mm</p>  <p>VENTED GAS FIREPLACE HEATER - NOT FOR USE WITH SOLID FUELS. FOYER AU GAZ À ÉVACUATION - NE PAS UTILISER AVEC UN COMBUSTIBLE SOLIDE.</p> <p>ELECTRICAL SUPPLY/ ALIMENTATION ÉLECTRIQUE : 115V_60HZ less than / moins de 2 AMP</p> <p>For Use Only with Barrier (Part # 732-512) Follow installation instructions. Utiliser uniquement avec l'écran (n°732-512) Suivre les consignes d'installation.</p> <p>FPI Fireplace Products International Ltd. Delta, BC, Canada</p> <p>Made in Canada / Fabriqué au Canada</p>
<p>This appliance must be installed in accordance with local codes, if any; if none, follow the National Fuel Gas Code, ANSI Z223.1, or Natural Gas and Propane Installation Code, CSA B149.1. This appliance must be installed in accordance with the Standard CAN/CSA Z240 MH, Mobile Housing, in Canada, or with the Manufactured Home Construction and Safety Standard, Title 24 CFR, Part 3280, in the United States, or when such a standard is not applicable, ANSI/NCSBSCS A225.1/NFPA 501A, Manufactured Home Installations Standard or ANSI A119.2 or NFPA 501C Standard for Recreational Vehicles. For use with Fan Kit # 910-331 This appliance is only for use with the type of gas indicated on the rating plate and may be installed in an aftermarket, permanently located, manufactured (mobile) home where not prohibited by local codes. See owner's manual for details. Installer l'appareil selon les codes ou règlements locaux, ou, en l'absence de tels règlements, selon les codes d'installation ANSI Z223.1, National Fuel Gas Code ou CSA-B149.1 en vigueur. Installer l'appareil conformément aux codes et règlements locaux; en l'absence de telles normes, suivre le National Fuel Gas Code, ANSI Z223.1 ou le Natural Gas and Propane Installation Code, CSA B149.1. Cet appareil doit être installé selon la norme CAN/CSA-Z240, Série MM, Maison mobiles ou CAN/CSA-Z240 VC, Véhicules de camping, ou la norme 24 CFR Part 3280, Manufactured Home Construction and Safety Standard aux États-Unis. Si ces normes ne s'appliquent pas, utiliser la norme ANSI/NCSBSCS A225.1/NFPA 501A, Manufactured Home Installations Standard, ou ANSI A119.2 ou NFPA 501C Standard for Recreational Vehicles. À utiliser avec la trousse du ventilateur n°910-331. Cet appareil doit être utilisé uniquement avec le type de gaz indiqué sur la plaque signalétique. Cet appareil peut être installé dans une maison préfabriquée (mobile) installée à demeure (E.-U. seulement) si les règlements locaux le permettent. Voir la notice de l'utilisateur pour plus de renseignements. Voir le manuel d'installation pour plus de détails. This vented gas fireplace heater is not for use with air filters. Ne pas utiliser de filtre à air avec ce foyer au gaz à évacuation. For use with glass doors certified with the appliance only. À utiliser uniquement avec p portes en verre certifiées avec l'appareil.</p>		
<p>Intertek 919-972a</p> <p>CSA P.4.1 Fireplace Efficiency (FE)/Efficacité énergétique des foyers (EEF) CSA P.4.1 Natural Gas / Gaz naturel 63.94% Propane Gas / Gaz propane 64.59%</p>		

For the State of Massachusetts, installation and repair must be done by a plumber or gas fitter licensed in the Commonwealth of Massachusetts.

For the State of Massachusetts, flexible connectors shall not exceed 36 inches in length.

For the State of Massachusetts, the appliances individual manual shut-off must be a t-handle type valve.

The State of Massachusetts requires the installation of a carbon monoxide alarm in accordance with NFPA 720 and a CO alarm with battery back up in the same room where the gas appliance is installed.

Decal Location



Lower access panel and locate the rating located on the back of the access panel (see image below).

DO NOT REMOVE FROM THE UNIT.



installation

Gas Installation Checklist

This general checklist does not contain all pertinent installation details or specifics and does not supersede the guidelines in this manual. Your Regency dealer/installer should use it in conjunction with manual instructions. Please follow all local codes and jurisdictions in authority.

Customer: _____	Date Installed: _____
Install Address: _____	Location of Fireplace: _____
Serial No: _____	Installer: _____
Model No: _____	

Site Requirements	YES	NO
If applicable, are the insulation, vapour barrier, and drywall present if installed on an outside wall or chase?		
Does the area have a solid continuous base to support the unit?		
Will the area accommodate the size of the appliance and all clearances?		
Are the gas and electrical roughed into the area where the unit is being installed?		
In City & Grandview series cool wall applications, is the chase enclosure sealed to prevent heat from escaping? All hot air from the unit must exit via the mandatory ventilation openings.		
In City & Grandview applications, Is the chase enclosure vented with the mandatory heat ventilation openings? See manual for details.		
If applicable, is the masonry/factory built fireplace in its original condition with no modifications?		
If applicable, have the hearth requirements been met?		
Unit Setup	YES	NO
If applicable, are the standoffs and top nailing flange extensions installed and at the correct depth to accommodate finishing material? See manual for details.		
If applicable, is the fireplace level and secured, meeting framing clearances? See manual for details.		
If applicable, is the unit converted to top or rear vent per manual instructions, and the insulation discarded?		
Venting	YES	NO
Are the venting components approved for the unit installed?		
Does the venting configuration comply with venting diagrams?		
Is venting installed and secured, and are clearances for the vent pipe and termination cap maintained?		
If applicable, was a 1/4" rise maintained for every foot of horizontal run?		
Was the termination installed and sealed?		
Is the direct vent termination at the highest point in the vent assembly?		
If applicable, are both chimney liners continuous from flue collars to termination?		
Electrical and Wiring	YES	NO
Is the appliance connected to the household's 110/120v per local codes? Check local codes for receptacle placement.		
Were the connections in the fireplace tested with a circuit tester?		
Is the appliance properly grounded?		
If applicable, is the supplied electrical/gang box affixed to the wall to facilitate the mounting of the receiver/battery box ?		
Gas	YES	NO
Does the supply pressure meet the requirements shown on the rating plate?		
Was a conversion performed?		
Was a leak check performed and manifold pressures verified?		
Is the shut-off valve installed and easily accessible to the customer?		

Finishing	YES	NO
If applicable, is only noncombustible material installed in the noncombustible areas?		
Do clearances meet installation and manual requirements?		
Do the mantels and/or projections comply with the installation manual?		
If applicable, was the solid fuel fireplace warning plate installed?		
Appliance Media Setup	YES	NO
Do commands from the remote or wall switch light the pilot and main burner?		
Are the burner media/log set, glass door, and screen installed per instructions in the manual?		
Was the air shutter on the proper setting after running the unit for 20 minutes?		
If applicable, were the surround and trims installed according to the manual?		
Was the operation of the fan, lights (if installed), and flame modulation checked?		
Customer Tutorial and Presentation	YES	NO
Is the customer confident operating the new gas appliance and aware of all the features on the remote?		
Confirm that the rating and lighting plates are attached to the appliance. Do not remove.		
Was the customer informed of the location of the rating and lighting plates?		
Was accessing unit controls in a power outage explained to the customer?		
Are the model and serial numbers and the date of installation of the unit written in the manual and on the checklist?		
Were the warranty and unit registration reviewed with the customer?		
Comments:		

installation

Before You Start

Safe installation and operation of this appliance requires common sense, however, we are required by the Canadian Safety Standards and ANSI Standards to make you aware of the following:

INSTALLATION AND REPAIR SHOULD BE DONE BY AN AUTHORIZED SERVICE PERSON. THE APPLIANCE SHOULD BE INSPECTED BEFORE USE AND AT LEAST ANNUALLY BY A PROFESSIONAL SERVICE PERSON. MORE FREQUENT CLEANING MAY BE REQUIRED DUE TO EXCESSIVE LINT FROM CARPETING, BEDDING MATERIAL, ETC. IT IS IMPERATIVE THAT CONTROL COMPARTMENTS, BURNERS AND CIRCULATING AIR PASSAGEWAYS OF THE APPLIANCE BE KEPT CLEAN.

DUE TO HIGH TEMPERATURES, THE APPLIANCE SHOULD BE LOCATED OUT OF TRAFFIC AND AWAY FROM FURNITURE AND DRAPERIES.

WARNING: FAILURE TO INSTALL THIS APPLIANCE CORRECTLY WILL VOID YOUR WARRANTY AND MAY CAUSE A SERIOUS HOUSE FIRE.

CHILDREN AND ADULTS SHOULD BE ALERTED TO THE HAZARDS OF HIGH SURFACE TEMPERATURES, ESPECIALLY THE FIREPLACE GLASS, AND SHOULD STAY AWAY TO AVOID BURNS OR CLOTHING IGNITION.



YOUNG CHILDREN SHOULD BE CAREFULLY SUPERVISED WHEN THEY ARE IN THE SAME AREA AS THE APPLIANCE. TODDLERS, YOUNG CHILDREN AND OTHERS MAY BE SUSCEPTIBLE TO ACCIDENTAL CONTACT BURNS. A PHYSICAL BARRIER IS RECOMMENDED IF THERE ARE AT RISK INDIVIDUAL IN THE HOUSE. TO RESTRICT ACCESS TO A FIREPLACE OR STOVE, INSTALL AN ADJUSTABLE SAFETY GATE TO KEEP TODDLERS, YOUNG CHILDREN AND OTHER AT RISK INDIVIDUALS OUT OF THE ROOM AND AWAY FROM HOT SURFACES.

CLOTHING OR OTHER FLAMMABLE MATERIAL SHOULD NOT BE PLACED ON OR NEAR THE APPLIANCE.

A BARRIER DESIGNED TO REDUCE THE RISK OF BURNS FROM THE HOT VIEWING GLASS IS PROVIDED WITH THIS APPLIANCE AND SHALL BE INSTALLED FOR THE PROTECTION OF CHILDREN AND OTHER AT-RISK INDIVIDUALS

IF THE BARRIER BECOMES DAMAGED, THE BARRIER SHALL BE REPLACED WITH THE MANUFACTURER'S BARRIER FOR THIS APPLIANCE.

ANY SAFETY SCREEN, GUARD, OR BARRIER REMOVED FOR SERVICING AN APPLIANCE MUST BE REPLACED PRIOR TO OPERATING THE APPLIANCE.

WARNING: Cancer and Reproductive Harm
www.P65Warnings.ca.gov

919-874

Lighting Procedure

IMPORTANT: The remote control system supplied with this appliance has several options for starting/operating the appliance using the battery holder and ON/OFF key on the hand held transmitter.

Prior to operating this appliance, please read the remote control operating instructions (packaged with remote control) to understand how to operate this remote control system.

1. Ensure the battery holder switch is in the Remote position and / or wall mounted battery holder (if equipped) is in the <REMOTE> position.
2. Press and release the ON/OFF button on the remote handheld transmitter (see Diagram 1). An audible beep should be heard from the receiver. If not using the remote, the unit can also be turned on by sliding the battery holder switch to the <ON> position (if equipped).



Diagram 1
Remote shown in Manual Mode on Hi

3. After approximately 4 seconds the spark ignition system will spark for 60 seconds to light the pilot.
4. The unit will turn on.



Note: The first try for ignition will last approximately 60 seconds. If there is no flame ignition (rectification) the board will stop sparking for approximately 35 seconds. After wait time, the board will start second try for ignition by sparking for approximately 60 seconds. If there is still no positive ignition the board will go into lock out.

The system will need to be reset as follows:

- a) Turn the system off by pressing the ON/OFF button on the remote.
- b) Wait 5 minutes then repeat from step 2.

Shutdown Procedure

1. Press the ON/OFF button on the remote
2. If service is to be performed- you must disconnect power and shut off gas to the unit.

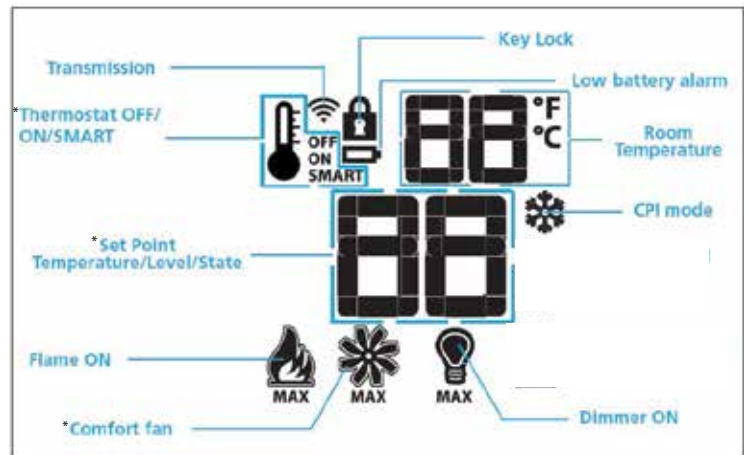

* Not offered on all models.

Fan Operation: The standard fan can be operated by using the remote control supplied with this unit. See remote control instructions.

Note: In thermostat mode: When the appliance is turned on, the fan will not come on for the first 5 minutes (if fan is turned on). When the appliance is turned off the fan will not turn off for 12 minutes (if in on position)

Manual mode: Fan will turn on and off immediately using the remote control transmitter if the fan function is in the "on" position.
Continuous Pilot/Intermittent Pilot (CPI/IPI) **selection**

See remote control instructions for details.

On Demand Pilot (seven day safety timer)

Important information if using the appliance in CPI (continuous pilot mode) only

This appliance is a ProFlame 2 system fitted with the "On Demand" Pilot, a safety feature which will shut down the gas valve completely by extinguishing the pilot light in the event of a continuous full seven days of inactivity. This only applies if the CPI (continuous pilot) switch is in the "on" position in your remote control transmitter.

Each time the main burner shuts down, manually or through the call from the thermostat, the seven day timer starts again.

The seven day inactivity timer is controlled within the circuit board. Therefore, if in CPI mode and when the pilot light is extinguished after seven straight days of inactivity, the CPI setting on the remote control transmitter will remain in the "CPI" (continuous pilot) position. Therefore, all that is required to relight the pilot would be to press the on/off button on the remote control transmitter from "on" to "off" and back to "on". Once the pilot has re-established operation will resume as normal. There is no requirement to do anything with the IPI/CPI mode on the remote control transmitter.

If the unit never goes as long as seven full days without a call for heat, the pilot will remain lit until it is manually shut-off.

If the unit is being operated in IPI (intermittent pilot) mode, neither the above instructions nor the seven day timer will apply.

See the instructions in this manual and on the Lighting Instructions plate on the appliance to light or re-light the pilot.

Copy of the Lighting Plate Instructions

**FOR YOUR SAFETY READ BEFORE LIGHTING
POUR VOTRE SÉCURITÉ – À LIRE AVANT LA MISE EN MARCHÉ**

WARNING: If you do not follow these instructions exactly, a fire or explosion may result causing property damage, personal injury or loss of life. Improper installation, adjustment, alteration, service or maintenance can cause injury or property damage. Refer to the owner's information manual provided with this appliance. For assistance or additional information consult a qualified installer, service agency or gas supplier.

AVERTISSEMENT : Quiconque ne respecte pas scrupuleusement les instructions de la présente notice risque de déclencher un incendie ou une explosion pouvant entraîner des dégâts matériels ou des blessures pouvant être mortelles. Tout défaut d'installation, de réglage, de modification, de service ou d'entretien peut entraîner des blessures ou des dommages matériels. Reportez-vous au manuel d'utilisation fourni avec cet équipement. Pour obtenir de l'aide ou des informations complémentaires, consulter un installateur ou un service d'entretien qualifié, ou le fournisseur de gaz.

- A) This appliance is equipped with an ignition device which automatically lights the pilot.
Do not try to light the pilot by hand.
- B) **BEFORE OPERATING** smell all around the appliance area for gas. Be sure to smell next to the floor because some gas is heavier than air and will settle on the floor.
WHAT TO DO IF YOU SMELL GAS
- Do not try to light any appliance.
 - Do not touch any electric switch, do not use any phone in your building.
 - Leave the building immediately.
 - Immediately call your gas supplier from a neighbours phone. Follow the gas supplier's instructions.
 - If you cannot reach your gas supplier, call the fire department.
- C) Do not use this appliance if any part has been under water. Immediately call a qualified service technician to inspect the appliance and to replace any part of the control system and any gas control which has been underwater.
- A) Cet appareil est muni d'un dispositif d'allumage qui allume automatiquement la veilleuse.
Ne tentez pas d'allumer la veilleuse manuellement.
- B) **AVANT LA MISE EN MARCHÉ**, renifluez tout autour de l'appareil pour déceler une odeur de gaz. Renifluez au niveau du plancher, car certains gaz sont plus lourds que l'air et peuvent s'accumuler au niveau du sol.
- QUE FAIRE SI VOUS SENTEZ UNE ODEUR DE GAZ :**
- Ne tentez pas d'allumer l'appareil
 - Ne touchez à aucun interrupteur; n'utilisez pas le téléphone se trouvant dans le bâtiment.
 - Quittez immédiatement le bâtiment.
 - Appelez immédiatement votre fournisseur de gaz depuis un téléphone extérieur. Suivez les instructions du fournisseur.
 - Si vous ne pouvez pas rejoindre le fournisseur, appelez le service incendie.
- C) N'utilisez pas cet appareil s'il a été plongé dans l'eau, même partiellement. Faites inspecter l'appareil par un technicien qualifié et remplacez tout élément du système de contrôle ou de commande qui a été plongé dans l'eau.

CAUTION: Hot while in operation. Do not touch. Severe burns may result. Due to high surface temperatures keep children, clothing and furniture, gasoline and other liquids having flammable vapors away. Keep burner and control compartment clean. See installation and operating instructions accompanying appliance.

ATTENTION : Surfaces chaudes lorsque l'appareil est en marche. Ne pas toucher. Risque de brûlures graves. En raison des températures élevées, les enfants, les vêtements et le mobilier, le carburant et tout autre liquide aux vapeurs inflammables doivent être tenus éloignés de l'appareil. Nettoyer régulièrement le brûleur et le compartiment des commandes. Voir les consignes d'installation et d'utilisation fournies avec l'appareil.

OPERATING INSTRUCTIONS / CONSIGNES DE FONCTIONNEMENT

- 1) **STOP! Read the safety information above on this label.**
 - 2) Ensure the Main switch is in the ON position and/or the wall mounted battery holder (if equipped) is in the <REMOTE> position.
 - 3) Press and release the ON/OFF button on the remote handheld transmitter. An audible beep should be heard from the receiver. If not using the remote, the unit can also be turned on by sliding the battery holder switch to the <ON> position (if equipped).
 - 4) After approximately 4 seconds the spark ignition system will spark for 60 seconds to light the main burner.
 - 5) The unit will turn on.
Note: The first attempt to ignition will last approximately 60 seconds. If there is no flame ignition (rectification) the board will stop sparking for approximately 35 seconds. After this wait time, the board will start a second try for ignition by sparking for approximately 60 seconds. If there is still no positive ignition after the second attempt the board will go into lock out.
The system will need to be reset as follows (after going into lock out mode):
 - a) Wait 5 minutes - turn the system off by pressing the ON/OFF button on the remote.
 - b) After approximately 2 seconds press the ON/OFF button again.
 - c) Unit will repeat step 2.
 - 6) If the appliance will not operate, follow the instructions, "To Turn Off Gas to Appliance" and call your service technician or gas supplier. This appliance is equipped with an on-demand pilot that shuts off after seven days.
- 1) **STOP! Lisez les instructions de sécurité sur la portion supérieure de cette étiquette.**
 - 2) S'assurer que le commutateur principal est en position ON et/ou que le bloc-piles mural (le cas échéant) est en position <REMOTE>.
 - 3) Appuyer sur la touche ON/OFF de la télécommande puis relâcher. Un bip sonore retentira depuis le récepteur. Si vous n'utilisez pas la télécommande, l'appareil peut également être allumé en faisant glisser le commutateur du bloc-piles sur la position <ON> (le cas échéant).
 - 4) Après environ 4 secondes, le système d'allumage produira une étincelle pendant 60 secondes pour allumer le brûleur principal.
 - 5) L'appareil s'allumera.
Remarque : Au premier allumage, le système tente d'allumer les flammes pendant 60 secondes. Si l'essai est infructueux, le système fera une pause de 35 secondes. C'est ce qu'on appelle l'étape de rectification. Ce délai écoulé, le système tente à nouveau d'allumer les flammes en produisant des étincelles pendant 60 secondes. Si les flammes ne s'allument toujours pas, le système se met en mode verrouillage.
Il faut alors le réinitialiser en suivant les étapes ci-dessous (pour le déverrouiller) :
 - a) Attendre 5 minutes et éteindre l'appareil en appuyant sur la touche ON/OFF de la télécommande.
 - b) Attendre 2 secondes et appuyer encore une fois sur la touche ON/OFF.
 - c) L'appareil répètera l'étape 2.
 - 6) Si l'appareil ne fonctionne pas, suivez les instructions "Pour couper le gaz au niveau de l'appareil" et appelez un technicien qualifié ou votre fournisseur de gaz.
Cet appareil est équipé d'une veilleuse sur demande qui s'éteint après sept jours.

TO TURN OFF GAS TO APPLIANCE / POUR COUPER LE GAZ AU NIVEAU DE L'APPAREIL

- 1) Press the ON/OFF button on the remote or slide the wall mount switch to the "OFF" position.
- 2) If service is to be performed—you must disconnect power and shut off gas to the unit.
- 1) Appuyer sur la touche ON/OFF de la télécommande ou faites glisser l'interrupteur mural sur la position "OFF".
- 2) Lors de l'entretien de l'appareil, vous devez débrancher l'alimentation électrique et couper le gaz alimentant l'appareil.

DO NOT REMOVE THIS INSTRUCTION PLATE

NE PAS ENLEVER CETTE ÉTIQUETTE D'INSTRUCTIONS

919-649b

Proflame II Remote Control Operating Instructions

IMPORTANT: The Proflame Transmitter 2 is an integrated part of the Proflame 2 System, which consists of these elements:

- Proflame 2 Transmitter, to be used in conjunction with:
- Integrated Fireplaces Control (Proflame 2 IFC)

The Proflame 2 Transmitter provides for controlling the following hearth appliance functions:

1. Main Burner On/Off
2. Main Burner flame modulation (6 levels)
3. Choice of standing or intermittent pilot (CPI/IPI)
4. Thermostat and Smart thermostat functions
5. Accent light modulation (6 levels)**
6. Split flow valve**
7. Comfort Fan speed modulation (6 levels)**

** This feature is not available on any Hampton models.

The Proflame Transmitter uses a streamline design with a simple button layout and informative LCD display (Fig. 1). A Mode Key is provided to index between the features and a Thermostat Key is used to turn on/off or index through Thermostat functions (Fig. 1 & 2). Additionally, a Key Lock feature is provided (Fig. 22).



Figure 1: Proflame Transmitter

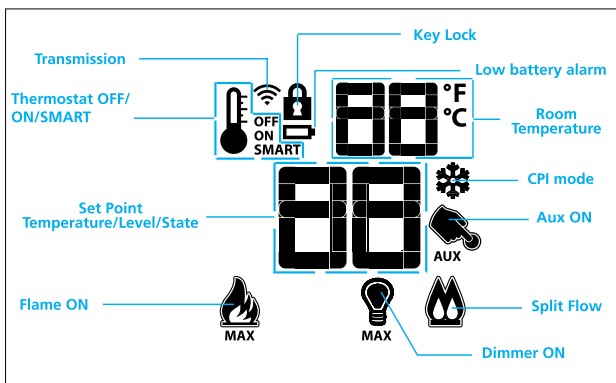

Figure 2: Transmitter LCD Display



TECHNICAL DATA REMOTE CONTROL

Supply Voltage	4.5V (three 1.5V AAA batteries)
Ambient temperature ratings	0 - 50°C (32 - 122°F)
Radio Frequency	315 MHZ

WARNING: THE TRANSMITTER AND IFC ARE RADIO FREQUENCY DEVICES.

ATTENTION!

- Turn "OFF" the main gas supply of the appliance during installation or maintenance of the IFC.

- Turn "OFF" main gas supply to the appliance prior to removing or reinserting the batteries.

- In case of remote control malfunction, turn off the IFC device using the "ON/OFF" main switch.

- For installation / maintenance, switch off the IFC device removing main power supply plug.

Pairing the remote control to remote receiver / battery holder (if required)

Power the receiver. Press the PRG button located on the top right hand corner of receiver. The receiver will beep three times to indicate that it is ready to synchronize with a transmitter. Install the 3 AAA type batteries in the transmitter battery bay, located on the base of the transmitter (fig. 3). With the batteries already installed in the transmitter, push the ON button. The receiver's command is accepted and sets to the particular code of that transmitter. The system is now initialized.

(*) The receiver may be independent or integral to the IFC hearth appliance control module. The receiver instruction may not be independent when part of the IFC.



Figure 3: Battery Compartment

Temperature indication Display

With the system in the "OFF" position, press the Thermostat Key and the Mode Key at the same time. Look at the LCD screen on the transmitter to verify that a C or F is visible to the right of the room temperature display (Figures 4 & 5).

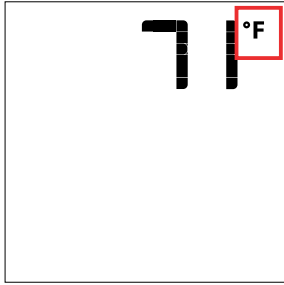

Figure 4: Remote Control display in Fahrenheit.

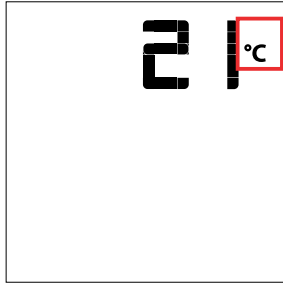

Figure 5: Remote Control display in Celsius.

Turn on the Appliance

With the system OFF, press the ON/OFF Key on the Transmitter. The Transmitter display will show some other active Icons on the screen. At the same time the IFC will activate the appliance. A single "beep" from the IFC will confirm reception of the command.

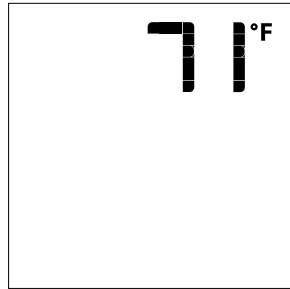

Figure 6: Remote Control display

Turn off the Appliance

With the system ON, press the ON/OFF Key on the Transmitter. The Transmitter LCD display will only show the room temperature (Fig. 6). At the same time the IFC will turn off the appliance. A single "beep" from the IFC confirms reception of the command.

Remote-Flame Control

The Proflame has six (6) flame levels. With the system on, and the flame level at the maximum in the appliance, pressing the Down Arrow Key once will reduce the flame height by one step until the flame is turned off. The Up Arrow Key will increase the flame height each time it is pressed. If the Up Arrow Key is pressed while the system is on but the flame is off, the flame will come on in the high position. (Fig. 7 & 8) A single "beep" will confirm reception of the command.

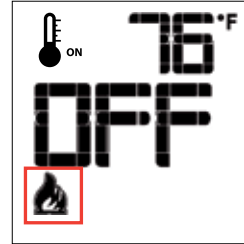

Flame Off

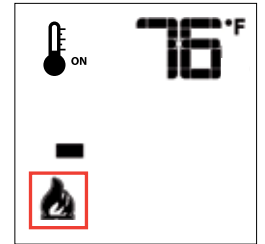

Flame Level 1

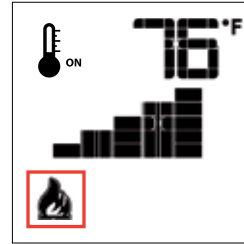

Flame level 5

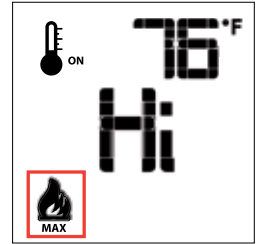

Flame Level Maximum

Fig. 7

Fig. 8

Room Thermostat (Transmitter Operation)

The Remote Control can operate as a room thermostat. The thermostat can be set to a desired temperature to control the comfort level in a room. To activate this function, press the Thermostat Key (Fig. 1). The LCD display on the Transmitter will change to show that the room thermostat is "ON" and the set temperature is now displayed (Fig. 9). To adjust the set temperature, press the Up or Down Arrow Keys until the desired set temperature is displayed on the LCD screen of the Transmitter.

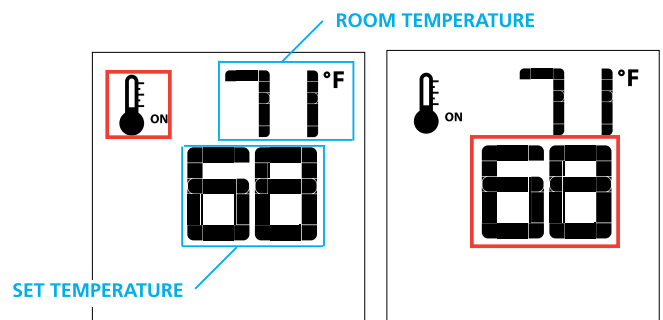

Figure 9

Figure 10

Smart Thermostat (Transmitter Operation)

The Smart Thermostat function adjusts the flame height in accordance to the difference between the set point temperature and the actual room temperatures. As the room temperature gets closer to the set point the Smart Function will modulate the flame down.

To activate this function, press the Thermostat Key (Fig. 1) until the word "SMART" appears to the right of the temperature bulb graphic (Fig. 11). To adjust the set temperature, press the Up or Down Arrow Keys until the desired set temperature is displayed on the LCD screen of the Transmitter (Fig. 12).

Note. When Smart Thermostat is activated, manual flame height adjustment is disabled.

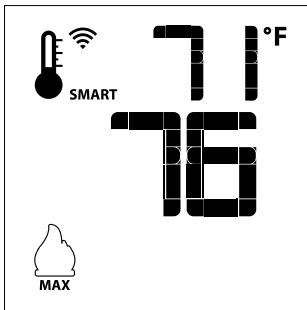

Figure 11: Smart Flame Function

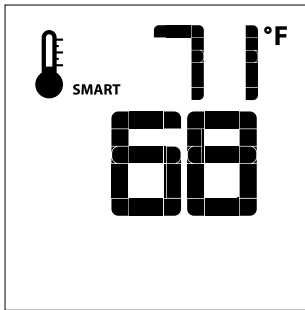

Figure 12

Fan Speed Control**

If the appliance is equipped with a hot air circulating fan, the speed of the fan can be controlled by the Proflame system. The fan speed can be adjusted through six (6) speeds. To activate this function use the Mode Key (fig.1) to index to the fan control icon (Fig. 13). Use the Up/Down Arrow Keys (fig.1) to turn on, off or adjust the fan speed (fig. 14). A single "beep" will confirm reception of the command.

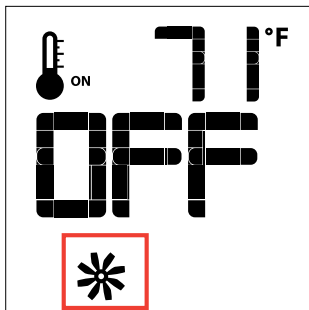

Figure 13

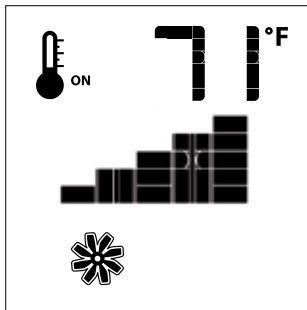

Figure 14

Remote dimmer control (Light)**

The auxiliary function controls the AUX power outlet by the dimmable light control. To activate this function use the Mode Key (fig. 1) to index to the AUX icon (fig. 15 & 16).

The intensity of the output can be adjusted through six (6) levels. Use the Up/Down Arrow Keys (Fig.1) adjust the output level (Fig. 16). A single "beep" will confirm reception of the command.

Note: This function is available only with the IFC Control Module.

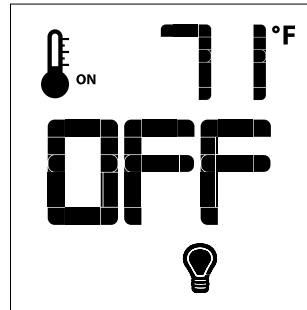

Figure 15

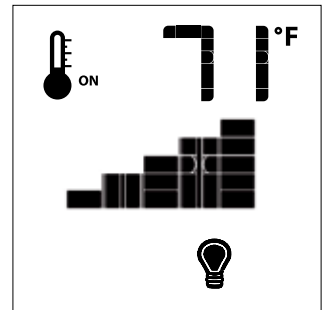

Figure 16

Split Flow control**

The secondary burner is controlled by the split Flow. To activate this function use the Mode Key (fig. 1) to index to the SPLIT FLOW mode icon (fig. 17 & 18).

Pressing the Up Arrow Key will activate the secondary burner. Pressing the Down Arrow Key will turn the secondary burner off. A single "beep" will confirm the reception of the command.

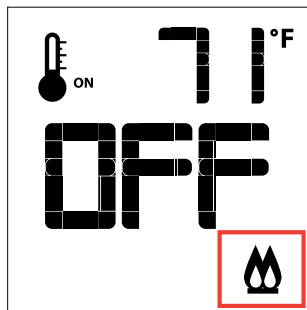

Figure 17

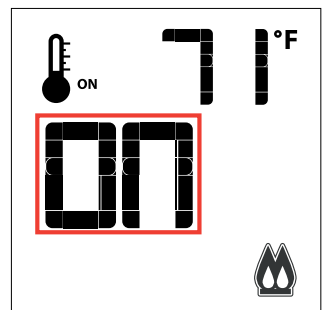

Figure 18

Continuous Pilot/Intermittent Pilot (CPI/IPI) selection

Note: Power vent models do not have a Continuous Pilot option.

With the system in "OFF" position press the Mode Key (fig. 1) to index to the CPI mode icon (fig. 19 & 20). Pressing the Up Arrow Key will activate the Continuous Pilot Ignition mode (CPI). Pressing the Down Arrow Key will return to IPI. A single "beep" will confirm the reception of the command.

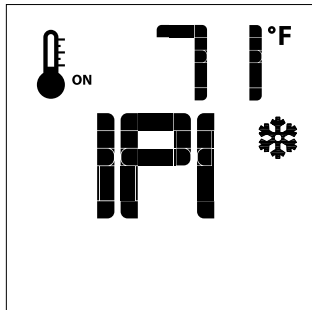

Figure 19

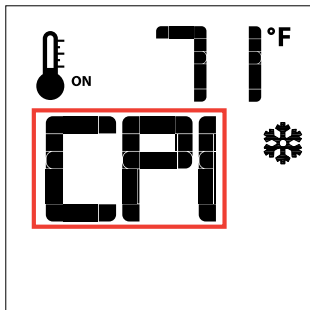

Figure 20

CPI/IPI Switch

This appliance comes equipped with a CPI/IPI switch. The functions of both the CPI/IPI switch are as follows:

Continuous pilot (CPI) - A pilot that when in operation, is intended to remain continuously ignited until it is manually interrupted.

Intermittent pilot (IPI) - A pilot that is automatically ignited when an appliance is called on to operate and which remains continuously ignited during each period of main burner operation. The pilot is automatically extinguished when each main burner operating cycle is completed. The mode of the fireplace is easily changed from an intermittent pilot ignition system (IPI) to a continuous pilot ignition system (CPI) by using remote control as noted above.

The benefits of having as CPI are as follows:

- Keeps venting primed for trouble free start-up under colder weather conditions or inversions.
 - Keeps the unit glass warm, which decreases the amount of condensation on start-up
 - Provides owners with flexibility to choose a traditional continuous pilot.
- The primary benefit of having the IPI function is a significant savings on fuel as the pilot will only run when there is a call for heat.

Thermostat Icon: If the thermostat icon is not present on the remote transmitter, follow instructions noted below:

1. Remove one battery from the remote.
2. Press and hold down the Thermostat button on the remote.
3. Reinstall the battery (removed in Step 1) while still holding down thermostat button.
4. If you see "Set" the thermostat option is now enabled. If you see "Clr" the thermostat option is now disabled.
5. Repeat the procedure if the "Set" or "Clr" to remove or add the option back to the remote did not appear.

Enable all other functions if not present on the remote transmitter, follow instructions noted below:

1. Remove one battery from remote.
2. Press and hold both the **ON/OFF** and **MODE** button at the same time .
3. Reinstall battery removed in Step 1 while holding both buttons—keep holding buttons, then release the **MODE** button only.
4. The screen will show either "Clr" or "Set" as the first option available is to disable or enable a mode.

5. "Clr" will remove a mode—use the up or down arrow while holding down **ON/OFF** and **MODE** (mode icon will disappear once removed).
6. Use the "**MODE**" button to move to the next function.
7. "Set" will add a mode —use the up or down arrow while holding down **ON/OFF** and **MODE** (mode icon will appear when added).
8. Use the "**MODE**" button to move to the next function.

Note: You should never program out the fan (if installed) or CPI/IPI mode on the remote.

Key Lock

This function will lock the keys to avoid unsupervised operation.

To activate this function, press the MODE and UP Keys at the same time (fig. 21).

To de-activate this function, press the MODE and UP Keys at the same time.

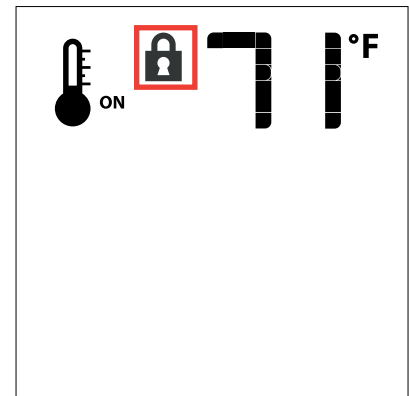

Figure 21

Low Battery Power Detection Transmitter

The life span of the remote control batteries depends on various factors: quality of the batteries used, the number of ignitions of the appliance, the number of changes to the room thermostat set point, etc.

When the Transmitter batteries are low, a Battery Icon will appear on the LCD display of the Transmitter (Fig. 22) before all battery power is lost. When the batteries are replaced this Icon will disappear.

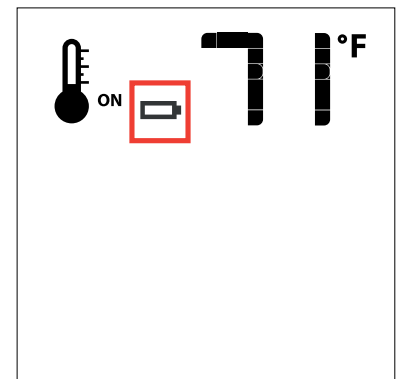

Figure 22

Proflame II Battery Holder Battery Replacement & Battery Back Up if 120 Volt Power is lost

How to replace/add the batteries on battery holder (Proflame 2).

Note : If a wall switch cover plate is installed, first remove cover plate by removing 2 small phillips head screws

STEP 1

Move both the left/right slides
as shown below.

The battery compartment
will be pushed out slightly,
to allow to easily extract it

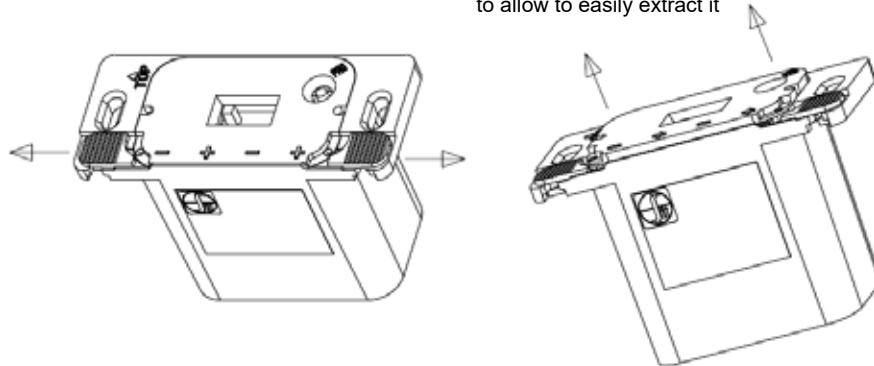

STEP 2

Extract the battery
compartment from the remote
receiver/battery holder

Replace 4 x AA batteries and insert the battery
compartment back into remote receiver/battery holder

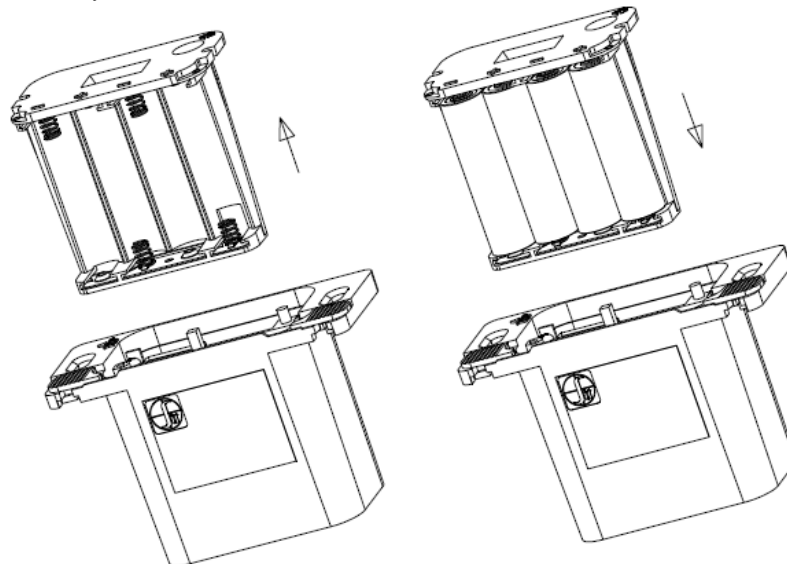

STEP 3

Keeping the battery compartment
pressed in, close the left slide

Close the right slide

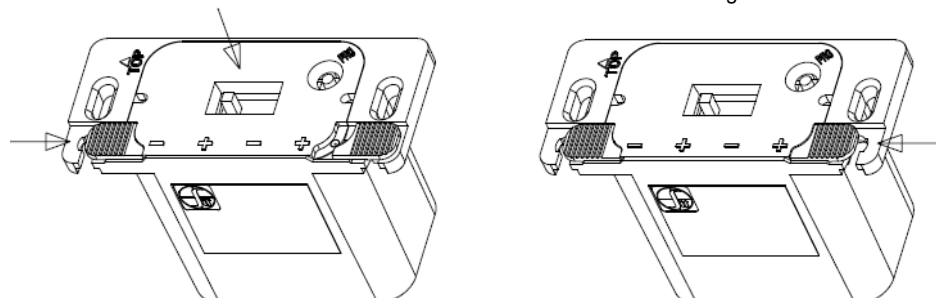

STEP 4 Reinstall wall cover plate with 2 Phillips head screws.

**MA Code - CO Detector
(for the State of Massachusetts only)**

5.08: Modifications to NFPA-54, Chapter 10

(2) Revise 10.8.3 by adding the following additional requirements:

(a) For all side wall horizontally vented gas fueled equipment installed in every dwelling, building or structure used in whole or in part for residential purposes, including those owned or operated by the Commonwealth and where the side wall exhaust vent termination is less than seven (7) feet above finished grade in the area of the venting, including but not limited to decks and porches, the following requirements shall be satisfied:

1. **INSTALLATION OF CARBON MONOXIDE DETECTORS.** At the time of installation of the side wall horizontal vented gas fueled equipment, the installing plumber or gasfitter shall observe that a hard wired carbon monoxide detector with an alarm and battery back-up is installed on the floor level where the gas equipment is to be installed. In addition, the installing plumber or gasfitter shall observe that a battery operated or hard wired carbon monoxide detector with an alarm is installed on each additional level of the dwelling, building or structure served by the side wall horizontal vented gas fueled equipment. It shall be the responsibility of the property owner to secure the services of qualified licensed professionals for the installation of hard wired carbon monoxide detectors

a. In the event that the side wall horizontally vented gas fueled equipment is installed in a crawl space or an attic, the hard wired carbon monoxide detector with alarm and battery back-up may be installed on the next adjacent floor level.

b. In the event that the requirements of this subdivision can not be met at the time of completion of installation, the owner shall have a period of thirty (30) days to comply with the above requirements; provided, however, that during said thirty (30) day period, a battery operated carbon monoxide detector with an alarm shall be installed.

2. **APPROVED CARBON MONOXIDE DETECTORS.** Each carbon monoxide detector as required in accordance with the above provisions shall comply with NFPA 720 and be ANSI/UL 2034 listed and IAS certified.

3. **SIGNAGE.** A metal or plastic identification plate shall be permanently mounted to the exterior of the building at a minimum height of eight (8) feet above grade directly in line with the exhaust vent terminal for the horizontally vented gas fueled heating appliance or equipment. The sign shall read, in print size no less than one-half (1/2) inch in size, "**GAS VENT DIRECTLY BELOW. KEEP CLEAR OF ALL OBSTRUCTIONS**".

4. **INSPECTION.** The state or local gas inspector of the side wall horizontally vented gas fueled equipment shall not approve the installation unless, upon inspection, the inspector observes carbon monoxide detectors and signage installed in accordance with the provisions of 248 CMR 5.08(2)(a)1 through 4.

(b) **EXEMPTIONS:** The following equipment is exempt from 248 CMR 5.08(2)(a)1 through 4:

1. The equipment listed in Chapter 10 entitled "Equipment Not Required To Be Vented" in the most current edition of NFPA 54 as adopted by the Board; and

2. Product Approved side wall horizontally vented gas fueled equipment installed in a room or structure separate from the dwelling, building or structure used in whole or in part for residential purposes.

(c) **MANUFACTURER REQUIREMENTS - GAS EQUIPMENT VENTING SYSTEM PROVIDED.** When the manufacturer of Product Approved side wall horizontally vented gas equipment provides a venting system design or venting system components with the equipment, the instructions provided by the manufacturer for installation of the equipment and the venting system shall include:

1. Detailed instructions for the installation of the venting system design or the venting system components; and

2. A complete parts list for the venting system design or venting system.

(d) **MANUFACTURER REQUIREMENTS - GAS EQUIPMENT VENTING SYSTEM NOT PROVIDED.** When the manufacturer of a Product Approved side wall horizontally vented gas fueled equipment does not provide the parts for venting the flue gases, but identifies "special venting systems", the following requirements shall be satisfied by the manufacturer:

1. The referenced "special venting system" instructions shall be included with the appliance or equipment installation instructions; and

2. The "special venting systems" shall be Product Approved by the Board, and the instructions for that system shall include a parts list and detailed installation instructions.

(e) A copy of all installation instructions for all Product Approved side wall horizontally vented gas fueled equipment, all venting instructions, all parts lists for venting instructions, and/or all venting design instructions shall remain with the appliance or equipment at the completion of the installation.

Important Message

SAVE THESE INSTRUCTIONS

The ULTIMATE Freestanding Gas Stove must be installed in accordance with these instructions. Carefully read all the instructions in this manual first. Consult the "authority having jurisdiction" to determine the need for a permit prior to starting the installation.

General Safety Information

1. The appliance installation must conform with local codes or, in the absence of local codes, with the current Canadian or National Gas Codes, CAN1-B149 or ANSI-223.1 Installation Codes.
2. The appliance when installed, must be electrically grounded in accordance with local codes, or in the absence of local codes with the current National Electrical Code, ANSI/NFPA 70 or CSA C22.1 Canadian Electrical Code.
3. This appliance is Listed for bedroom installations when used with a Listed Millivolt Thermostat. Some areas may have further requirements, check local codes before installation.
4. This appliance is listed for Alcove installations, maintain minimum Alcove clearances as follows, minimum ceiling height of 66", minimum width of 48" and a maximum depth of 36".
5. This unit is not approved for installation into a mobile home.
6. See general construction and assembly instructions.
7. This appliance must be connected to a vent and terminate to the outside of the building envelope. Never vent to another room or inside a building.
8. Inspect the venting system annually for blockage and any signs of deterioration.
9. Any safety glass removed for servicing must be replaced prior to operating the appliance.
10. To prevent injury, do not allow anyone who is unfamiliar with the operation to use the fireplace.
11. Wear gloves and safety glasses for protection while doing required maintenance.

12. Under no circumstances should this appliance be modified. Parts that have to be removed for servicing should be replaced prior to operating this appliance.
 13. Installation and any repairs to this appliance should be done by a qualified service person. A professional service person should be called to inspect this appliance annually. Make it a practice to have all of your gas appliances checked annually.
 14. Do not strike the glass door.
 15. Under no circumstances should any solid fuels (wood, paper, cardboard, coal, etc.) be used in this appliance.
 16. The appliance area must be kept clear and free of combustible materials, (gases and other flammable vapours and liquids).
 17. Do not connect this gas appliance to chimney flue serving a separate solid-fuel burning appliance.
 18. **WARNING:** Operation of this appliance when not connected to a properly installed and maintained venting system or tampering with the blocked vent shutoff system can result in carbon monoxide (CO) poisoning and possible death.
 19. This appliance needs fresh air for safe operation and must be installed so there are provisions for adequate combustion and ventilation air.
5. Make gas connections. Refer to "Gas Connection" section.
Test the pilot. Must be as per diagram. Refer to "Pilot Adjustment" section.
 6. If necessary, see the "Conversion from NG to LPG" section and "Conversion to Lower BTU Rating" section.
 7. Test Gas Pressure. Refer to "Gas Pipe Pressure Testing" section .
 8. Install standard and optional features. Refer to the following sections where applicable:
 - a. Log Set
 - b. Front Door
 - c. Wall Thermostat
 - d. Remote Control
 - e. Safety Screen
 - f. Louver Installation
 9. Final check. Refer to the "Final Check" section.
- Before leaving this unit with the customer, the installer must ensure that the appliance is firing correctly and **operation fully explained to customer.**

This includes:

1. Locking the appliance to ensure the correct firing rate (rate noted on label) after burning appliance for 15 minutes.
2. If required, adjusting the primary air to ensure that the flame does not carbon. First allow the unit to burn for 15-20 min. to stabilize.

CAUTION: Any alteration to the product that causes sooting or carboning that results in damage is not the responsibility of the manufacturer.

Installation Checklist

1. Locate your appliance. Refer to the following sections:
 - a. Locating Your Ultimate Gas Stove
 - b. Exterior Vent Termination Locations
 - c. Clearance to Combustibles
 - d. Combustion and Ventilation Air
2. Install Louvers. Refer to the "Louver Installation" section.
3. Choose a venting option and install accordingly. Refer to the following sections where applicable:
 - a. DV Stove Horizontal Vent Kit Installation
 - b. Dura-Vent Termination Kit
 - c. Set Vent Restrictors. Refer to "Rigid Pipe Venting Arrangement" section.
 - d. Converting a Class-A Metal Chimney or Masonry Chimney to a Direct Vent system.
4. Install 4-AA batteries into receiver. This will enable operation of appliance manual when in "ON" position.

installation

Clearances to Combustibles

The clearances listed below are MINIMUM distances. Measure the clearance to both the appliance and the chimney connector. **(The farthest distance is correct if the two clearances do not coincide.)** For example, if the appliance is set as indicated in one of the figures but the connector is too close, move the stove until the correct clearance to the connector is obtained.

This unit can be installed on a solid combustible surface like a wood floor. This unit can also be installed directly on carpeting or vinyl when the bottom pedestal cover plate (provided with unit) is installed.

This appliance may be installed only with the clearances as shown in the situations pictured. Do not combine clearances from one type of installation with another in order to achieve closer clearances.

Use the minimum clearances shown in the diagrams below for installation with "B" vent.

Minimum ceiling height is 36" / 914mm from top of unit.

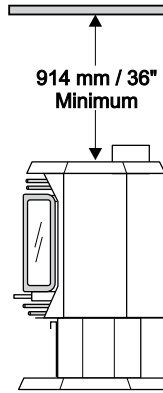

U38E-NG11 & U38E-LP11 Clearances

- A Side Wall to Unit 7-1/2" / 190 mm
- B Back Wall to Unit 6" / 155 mm
- E Side Wall to Unit 2" / 50 mm

U38E-NG11 & U38E-LP11 Reference Dimensions

- C Back Wall to Flue Centerline 10-3/4" / 273 mm
- D Side Wall to Flue Centerline 20-1/2" / 520 mm
- F Side Wall to Flue Centerline 11" / 280 mm

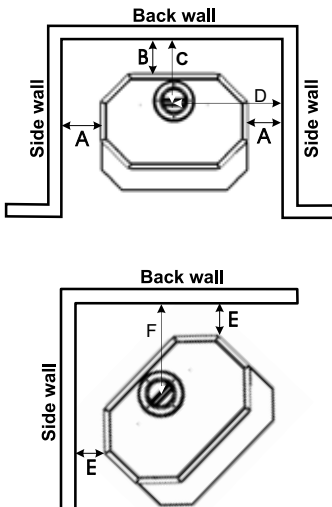

Optional Outside Air

Outside air for combustion can be brought in either through the bottom of the pedestal or through the rear plate of the pedestal.

For both bottom and rear "outside air" the Pedestal Cover Plate must be installed. Loosen the 4 screws on the rear of the pedestal and slide the cover plate over them. Slide the plate to the left to center it and tighten down the 4 screws.

Outside Air Through Pedestal Bottom

Once you have properly marked the position of your unit as outlined in "General Information" and "Clearances to Combustibles", cut a properly sized hole through the floor directly under your pedestal base to the outside. Pipe fresh air into the pedestal area by using appropriate metallic duct pipe with a mesh grill at the outside termination. Do not remove the knockout.

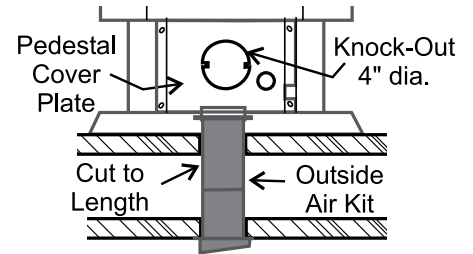

Rear View

Outside Air Through Rear of Pedestal

Remove the blanking plate from the rear of the pedestal cover plate and bend the two tabs out 90 degrees. Pipe fresh air into the pedestal area by using duct pipe with a mesh grill at the outside termination. Attach the pipe to the tabs with screws.

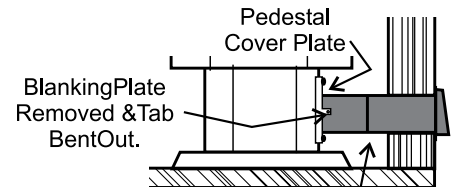

Side View

Draft Hood

This heater has a draft hood built in. It must not be altered, obstructed, or blocked in any way, and the unit must be installed so that the draft hood is in the same atmospheric pressure zone as the combustion air inlet to the burner. This heater must be properly connected to a venting system. This heater is equipped with a vent safety shutoff system.

WARNING: Operation of this heater when not connected to a properly installed and maintained venting system or tampering with the vent safety shutoff system can result in carbon monoxide (CO) poisoning and possible death.

High Elevation

The U38E-11 is approved in Canada for altitude 0 ft. to 4500 ft. (CSA-2.17-2017). For Natural Gas installations above 4500 ft. follow current CAN/CGA-B149.1-15.

In U.S.A., for installations above 2000 ft. refer to current ANSI Z223.1 Sc8-8.1.2a appendix F, for resizing orifice.

Venting

This heater is a vented appliance and must be connected to a chimney/flue in accordance with the installation codes.

Note: The rear pedestal cover plate is only required when outside air is being used. If using room air for combustion, remove this plate from the back of the pedestal.

For your safety this heater is equipped with a vent safety switch designed to sense incorrect venting and react by shutting down the gas supply. This thermally actuated switch is located within the draft hood and will detect either a blocked chimney or backdraft condition where the chimney flow has reversed. If this switch shuts the unit down, it indicates a drafting problem that must be identified and rectified without delay - the thermally activated switch must **never** be bypassed or disconnected as a hazardous or deadly condition can result.

Venting Requirements

A four inch diameter vent is required. B-Vent, Class A or Masonry with an approved liner are all acceptable. For cosmetic or aesthetic purposes 6" outer vent can be used as long as an approved inner vent is installed. Fasten but do not penetrate the inner sleeve of the B-Vent when tightening the screw.

Follow all venting manufacturer's requirements and local building codes. In cold climates, we recommend the use of insulated B-vent, chase, and liners. For altitudes above 2000 ft. we recommend that a minimum flue height of 12 ft. is used.

Flue Mounting Bracket

Attach the flue mounting bracket with the enclosed screw as shown in the diagram.

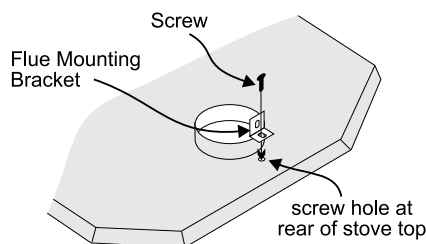

Vent Terminations

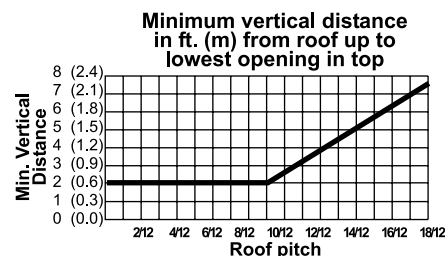
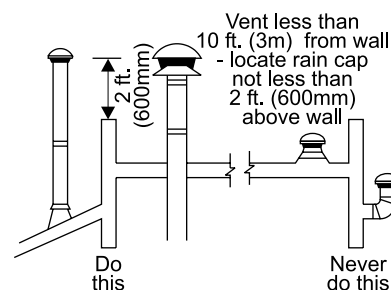

Installation into Existing Woodstove Flue System

- 1) Clean existing Chimney system.
- 2) Run an approved 4" flex liner or "B" vent into existing chimney.

Note: See the chimney systems manufacturer for detailed installation instructions.

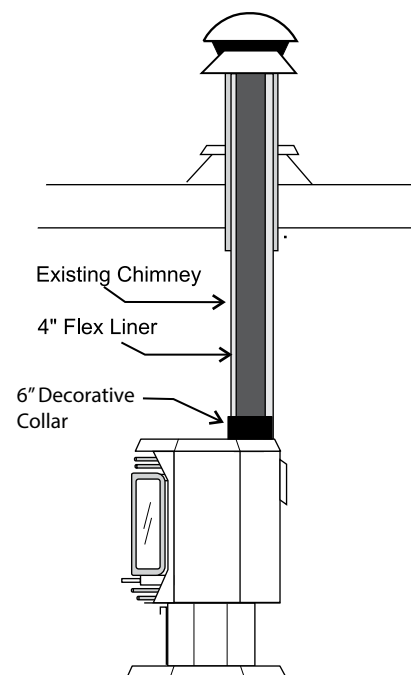

installation

Gas Connection

The gas line can be rigid pipe, or to make installation easier, use a listed flexible connector if allowed by local codes. Copper may also be used if approved by local codes.

The gas connection at the valve is 3/8" NPT. For minimum and maximum supply pressure see the System Data Table.

System Data U38E-11 with 38,000 BTU	
U38E-NG11: For 0 to 2000 feet altitude U38E-LP11: For 0 to 4500 feet altitude	
Burner Inlet Orifice Sizes:	
Burner	Natural Gas #32 Propane #50
Max. Input	
Natural Gas	38,000 Btu/h
Propane	34,000 Btu/h
Min. Input	
Natural Gas	26,000 Btu/h
Propane	27,500 Btu/h
Supply Pressure	
Natural Gas	min. 7" w.c.
Propane	min. 11" w.c.
Manifold Pressure	
Natural Gas	3.5" w.c.
Propane	10" w.c.
Electrical: 115_60Hz. Circulation: Variable speed fan, 125/75 CFM. Log Set: Ceramic fiber, 7 per set.	
System Data: HIGH ELEVATION - U38E-NG11	
For 2,000 - 4,500 feet altitude	
Burner Inlet Orifice Sizes:	
Natural Gas	Burner #33
Max. Input Rating	35,000 Btu/h
Min. Input Rating	24,000 Btu/h

System Data U38E-11 Converted to 30,000 BTU		
For 0 to 4500 feet altitude		
Burner Inlet Orifice Sizes:		
Burner	Natural Gas #37	Propane #52
Max. Input		
Natural Gas	30,000 Btu/h	
Propane	30,000 Btu/h	
Min. Input		
Natural Gas	21,000 Btu/h	
Propane	23,000 Btu/h	
Supply Pressure		
Natural Gas	min. 7" w.c.	
Propane	min. 11" w.c.	
Manifold Pressure		
Natural Gas	3.5" w.c.	
Propane	10" w.c.	
Electrical: 115_60Hz. Circulation: Variable speed fan, 125/75 CFM. Log Set: Ceramic fiber, 7 per set.		

Gas Pipe Pressure Testing

The appliance must be isolated from the gas supply piping system by closing its individual manual shut-off valve during any pressure testing of the gas supply piping system at test pressures equal to or less than 1/2 psig. (3.45 kPa). Disconnect piping from valve at pressures over 1/2 psig (14" w.c.).

The manifold pressure is controlled by a regulator built into the gas control, and should be checked at the pressure test point.

Note: To properly check gas pressure, both inlet and manifold pressures should be checked using the valve pressure ports on the valve.

1. Make sure the valve is in the "OFF" position.
2. Loosen the "IN" (# 7) and/or "OUT" (# 6) pressure tap(s), turning counterclockwise with a 1/8" wide flat screwdriver.
3. Attach manometer to "IN" and/or "OUT" pressure tap(s) using a 5/16" ID hose.
4. Light the pilot and turn the valve to "ON" position.

5. The pressure check should be carried out with the unit burning and the setting should be within the limits specified on the safety label.
6. When finished reading manometer, turn off the gas valve, disconnect the hose and tighten the screw (clockwise) with a 1/8" flat screwdriver. Screw should be snug, but do not over tighten.

885 S.I.T. Valve Description

- 1) 6 Stage flame adjustment
- 2) Pilot adjustment
- 3) Outlet Pressure Tap
- 4) Inlet Pressure Tap
- 5) Pilot Outlet
- 6) Main Gas Outlet
- 7) Main Gas Inlet

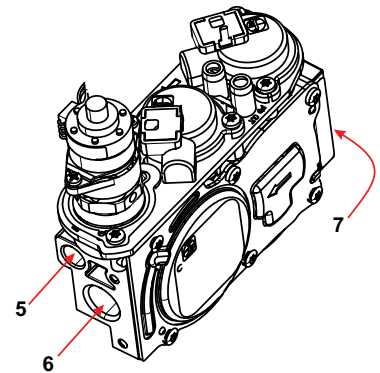
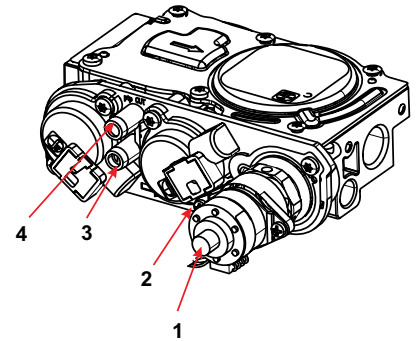

On Demand Pilot Light

Important: This appliance has a timer built into the pilot light.

The timer starts when the main burner has been shut-off by use of a remote control, thermostat or on/off switch. The timer is set for 7 days. If there has not been a call for heat for this 7 day period, the pilot is designed to extinguish.

See lighting instructions for lighting pilot.

Conversion Kit# 753-977 from NG to LP

**THIS CONVERSION MUST BE DONE BY A QUALIFIED GAS FITTER
IF IN DOUBT DO NOT DO THIS CONVERSION !!**

Each Kit contains one LPG Conversion Kit #753-977
LPG Conversion Kit Contains:

Qty.	Part #	Description
1	904-529	5/32" Allen Key
1	904-641	Burner Orifice #50
1	918-590	Label "Converted to LPG"
1	908-528	Red "LPG" label
1	910-037	LPG Injector (Pilot Orifice)
1	911-011	Stepper motor
1	919-993	Instruction Sheet

1. Shut off the gas and electrical supply.
2. Remove the safety screen, open the front door and carefully remove the logs and lava rock.
3. Remove burner. See diagram below.

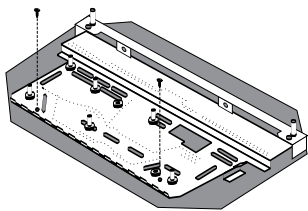

Note: Use a magnetic type screwdriver if possible.

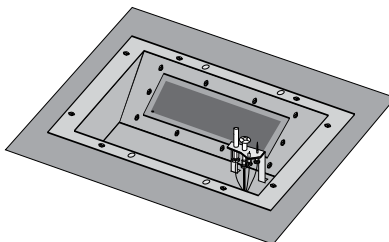

Pilot assembly is now accessible .

4. Open pedestal door and remove the chain from door which will allow door to fall.
5. Remove 2 screws that secure the front door to the unit. One screw is on the left hand side and the other on the right hand side. (Left side shown).



6. Remove four screws to remove the access panel (in locations shown below) and the chain attached to the front door and the unit.

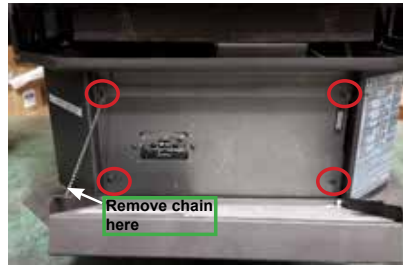

7. Turn control knob to the "OFF" position.
8. Remove NG stepper motor by removing 2 screws in locations shown below—replace with LP stepper motor, secure in place with 2 screws.

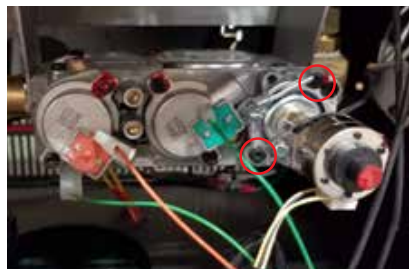

9. Pull off the pilot cap to expose the pilot orifice.



10. Unscrew the pilot orifice with the allen key and replace with the LPG pilot orifice in the kit.
11. Reinstall new burner orifice LPG stamped #50 and tighten.



12. Remove burner orifice with a 1/2" wrench while using a 9/16" wrench to hold onto the elbow behind the orifice, then discard the orifice.



Burner Orifice

13. Check for gas leaks with a proper soapy solution or leak detector.
14. Check for proper spark between the ignitor and pilot cap. Refer to "Lighting Procedure" section of the manual for lighting sequence.
15. Check pilot flames. Correct flame pattern has 3 strong blue flames. Adjustment can be made by turning the screw at the top right corner of the valve. Refer to "Maintenance Instructions" section of the manual for correct flame patterns.

16. Reverse Steps 9-1.
17. Attach the label "This unit has been converted to LPG" near or on top of the Serial # decal.
18. Replace yellow "NG" label with red "LPG" label.
19. Check operation of flame control.
20. The burner aeration should be set to 1/2" open for LP. See aeration adjustment details in the manual.
21. Check for proper flame appearance and glow on logs.

**Installer Notice:
These instructions must be left with the appliance.**

installation

Conversion to Lower BTU Rating

THIS CONVERSION MUST BE DONE BY A QUALIFIED GAS FITTER IF IN DOUBT DO NOT DO THIS CONVERSION !!

Natural Gas Conversion Kit 730-920

Contains:

- | Qty. | Part # | Description |
|------|---------|----------------------------------|
| 1 | 904-240 | Burner Orifice #37 (Natural Gas) |
| 1 | 918-034 | Decal "Converted to 30,000 Btu" |
| 1 | 918-033 | Instruction Sheet |

Propane Conversion Kit 730-922

Contains:

- | Qty. | Part # | Description |
|------|---------|---------------------------------|
| 1 | 904-390 | Burner Orifice #52 (Propane) |
| 1 | 918-034 | Decal "Converted to 30,000 Btu" |
| 1 | 918-033 | Instruction Sheet |

Additional Piece (pkg. with unit):

- | | |
|---|------------------------|
| 1 | Log Bracket Restrictor |
|---|------------------------|

Bracket Restrictor between the Rear Log Bracket and the burner, secure with the 2 screws.

- Remove burner orifice with a 1/2" wrench and discard.
- Reinstall new burner orifice (NG stamped #37 or LP stamped #52) and tighten.
- Reverse steps 3) and 2).
- Adjust Vent restrictor setting: To set the Vent restriction as indicated in the diagram, simply loosen the screws and push the vent restrictor plate to the correct position. Tighten the screws.

- Shut off the gas and electrical supply.
- Remove the safety screen - open the front door. Carefully remove the logs and lava rock.
- Remove burner. See diagram below.

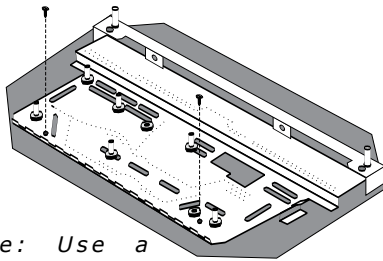

Note: Use a magnetic type screwdriver if possible.

- Unscrew the 2 Rear Log Pins and move to the front hole position.
- Remove Rear Log Bracket and slide the Log

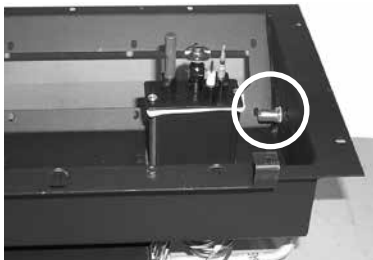

Burner Orifice

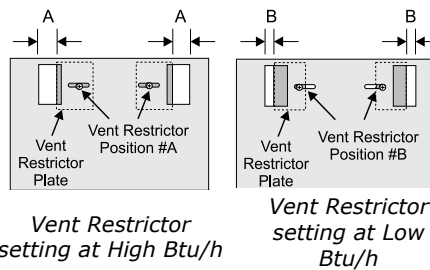

Unit	Btu/h	Restrictor Opening
U38E-11	38,000	A 1-3/8" (35mm)
U38E-11	30,000	B 1-1/8" (29mm)

- Attach the label "This unit has been converted to..." on top of the Serial # decal over the higher Btu information.
- Check for gas leaks.
- Check inlet and outlet pressures.
- Check operation of flame control. Check for proper flame appearance and glow on logs.

Log Set Installation

Read the instructions below carefully and refer to the diagrams. If logs are broken do not use the unit until they are replaced. Broken logs can interfere with the pilot operation.

The gas log kit contains the following:

- a) 02-65 Rear Log
- b) 02-56 Middle Left Log
- c) 02-44 Front Left Log
- d) 02-46 Left Top Log
- e) 02-45 Front Right Log
- f) 02-47 Center Log
- g) 02-48 Middle Right Log

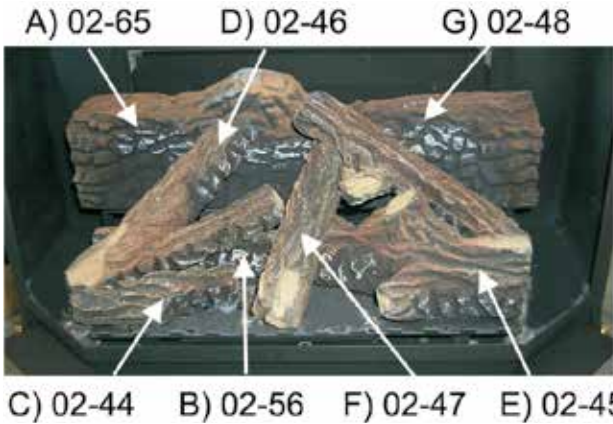

The "02" refer numbers (i.e. 02-65) are molded into the rear of each log.

1. Carefully remove the logs from the box and unwrap them. The logs are fragile, handle with care - **do not force into position.**
2. Place Rear Log A on the two pins on the rear log support.



Pins on Rear Log Support

3. Place the Middle Left Log B on the two pins as shown.



4. Place Front Left Log C onto the 2 front pins as shown.



5. Place the Left Top Log D on the pin on Log B and on top of the cut-out on Log A.

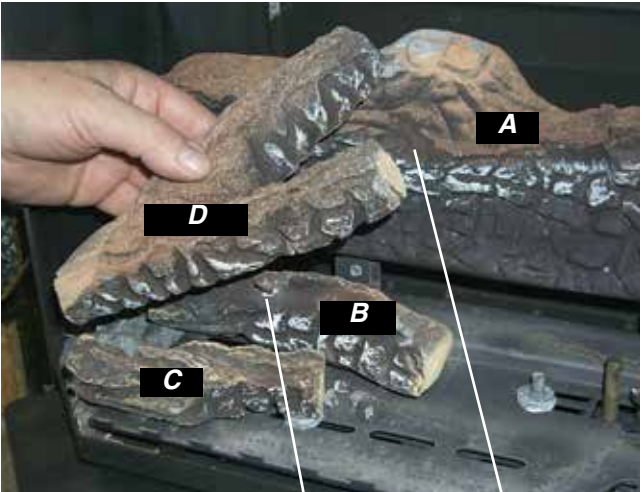

Pin Cutout

installation

6 Place Front Right Log E on the two pins as shown.



7. Place the notch in Center Log F over Log E and across the cut-out on Log A.

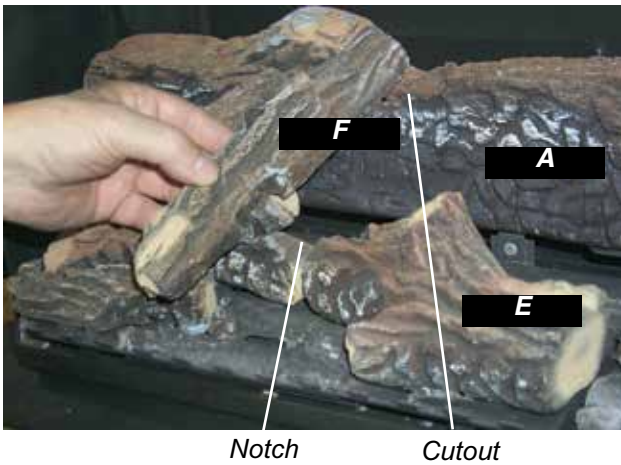

8. Position notch in Front Right Log G on Log F and push the bottom right edge against the bracket on the burner tray.

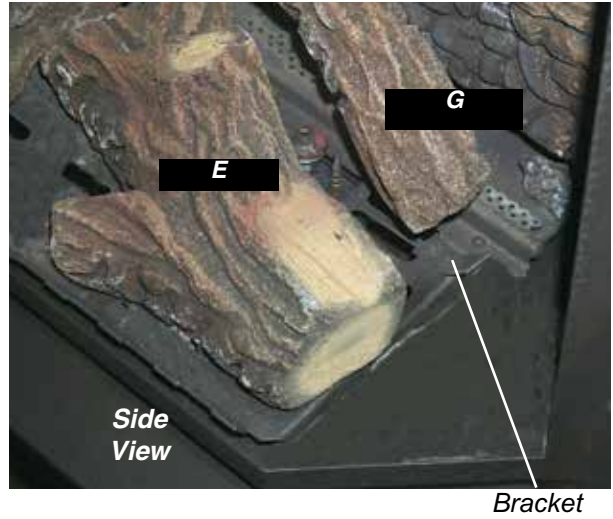
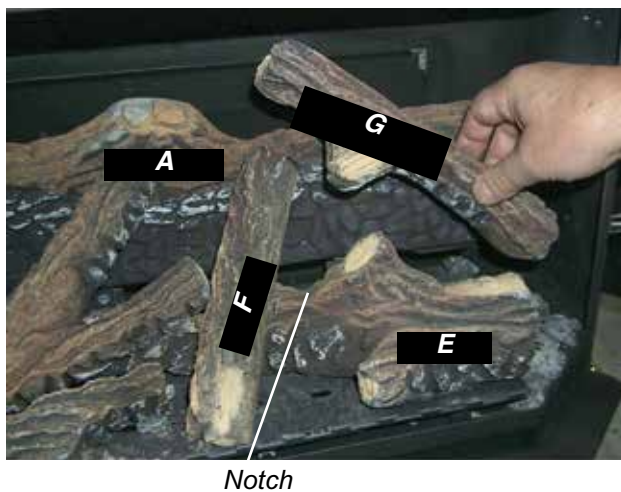

The bottom right edge of Log G must sit snugly against the bracket

9. Take the Embaglow, (steel wool like material) lightly separate it and set a small amount over the visible burner ports in front and between the front left log and the log under the “Y” log, indicated in the picture.

IMPORTANT: DO NOT compress this material down on the burner ports.

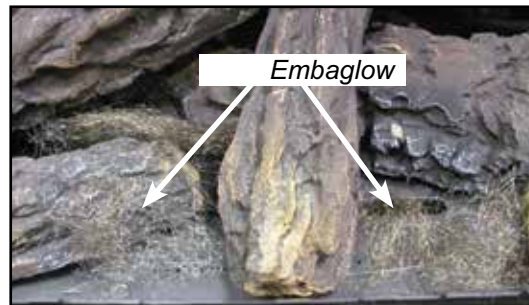

10. Next, take the white Platinum Ember material (provided) and gently separate the layers until you have a fine layer to place onto the Embaglow (steel wool type media).

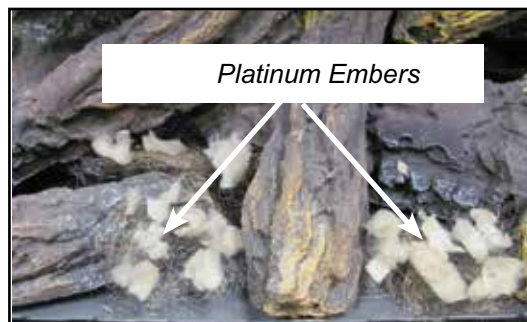

- Using the harder coal like embers carefully spread these around the **OUTSIDE** of the burner (1 cup on each side). Do not place or use these hard material embers on top of the burner.

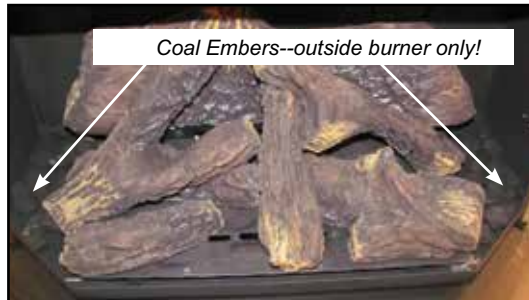

- Test fire to ensure proper light off (make sure flame flows smoothly from one end of burner to the other. If there is any flame hesitation, check that area for any blockage of the burner port.

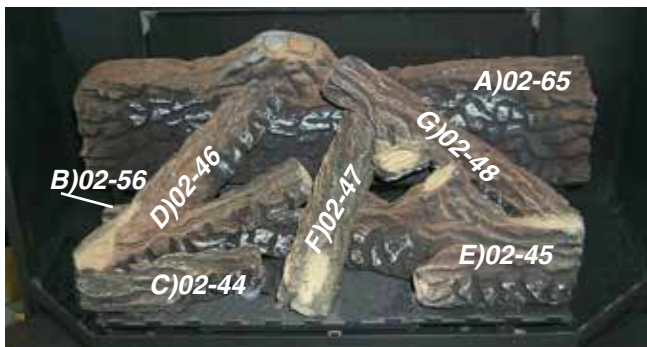

installation

Driftwood Log Set Installation

Read the instructions below carefully and refer to the diagrams. If logs are broken do not use the unit until they are replaced. Broken logs can interfere with the pilot operation.

The driftwood log kit contains the following:

- A Rear Log
- B Middle Left Log
- C Front Left Log
- D Left Top Log
- E Front Right Log
- F Center Log
- G Middle Right Log

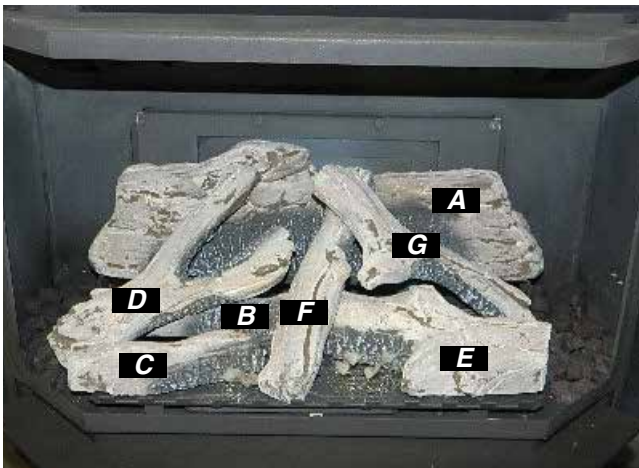

1. Carefully remove the logs from the box and unwrap them. The logs are fragile, handle with care - **do not force logs into position.**

2. Place Rear Log A on the two pins on the rear log support.

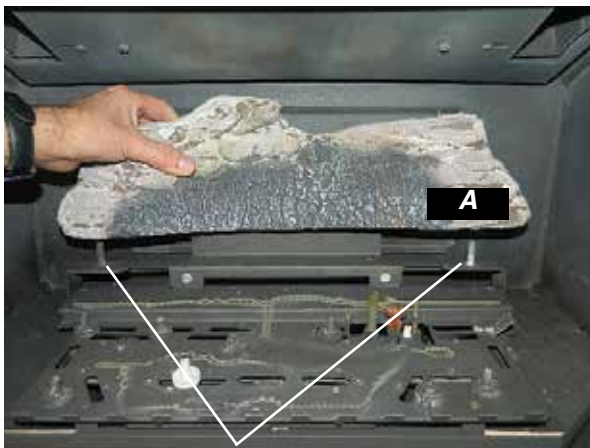

Pins on Rear Log Support

3. Place the Middle Left Log B on the two pins as shown.



4. Place Front Left Log C onto the 2 front pins as shown.



5. Place the Left Top Log D on the pin on Log B and on top of the cut-out on Log A.

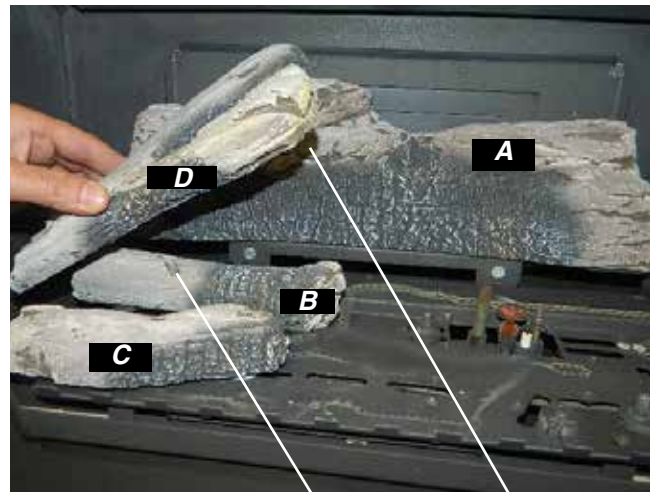

Pin

Cutout

6 Place Front Right Log E on the two pins as shown.

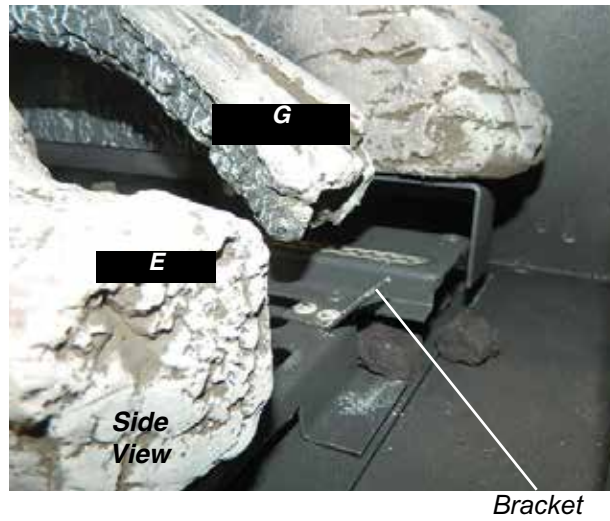

The bottom right edge of Log G must sit snugly against the bracket

7. Place the notch in Center Log F over Log E and across the cut-out on Log A.

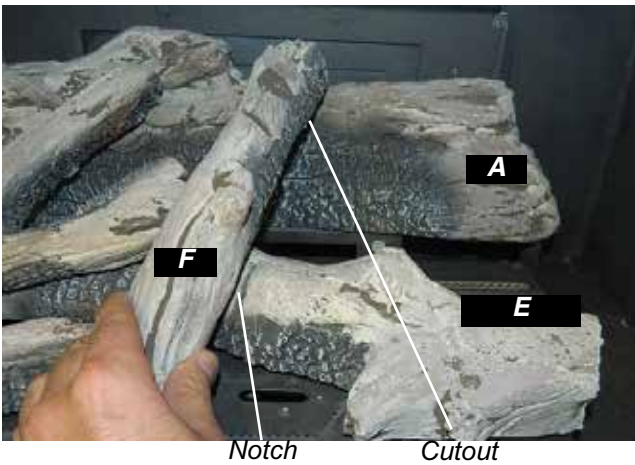

9. Take the Embaglow, (steel wool like material) lightly separate it and set a small amount over the visible burner ports in front and between the front left log and the log under the "Y" log, indicated in the picture.

IMPORTANT: DO NOT compress this material down on the burner ports.

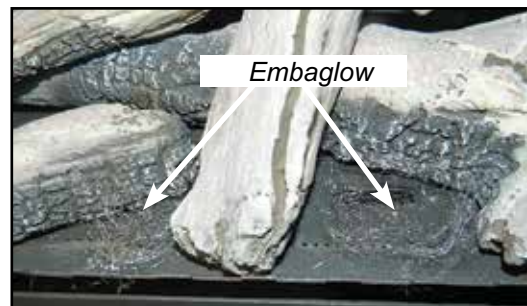

8. Position notch in Front Right Log G on Log F and push the bottom right edge against the bracket on the burner tray.

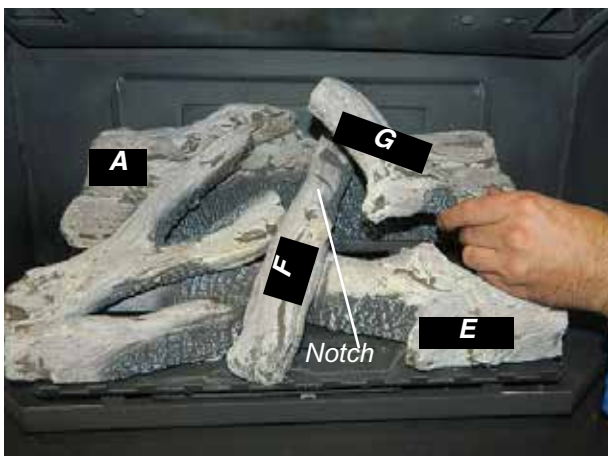

10. Next, take the white Platinum Ember material (provided) and gently separate the layers until you have a fine layer to place onto the Embaglow (steel wool type media).

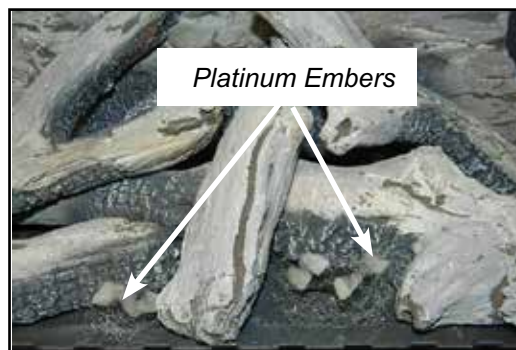

installation

11. Using the harder coal like embers carefully spread these around the **OUTSIDE** of the burner (1 cup on each side). Do not place or use these hard material embers on top of the burner.

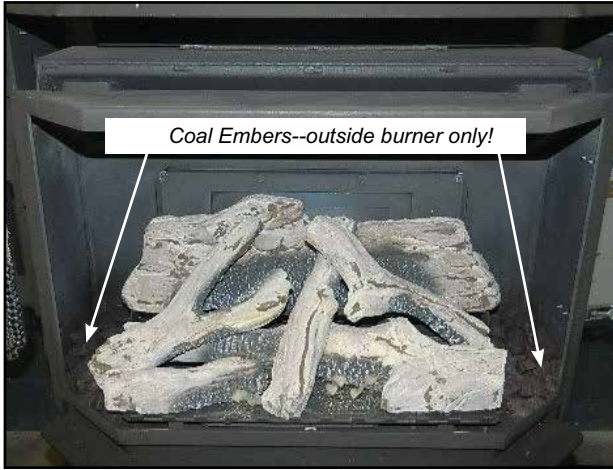

12. Test fire to ensure proper light off (make sure flame flows smoothly from one end of burner to the other. If there is any flame hesitation, check that area for any burner port blockage).

Front Door Installation

1) Open the two side panels.

2) Slide the door onto the two hinge pins making sure the two pieces are flush together. See diagram 1.

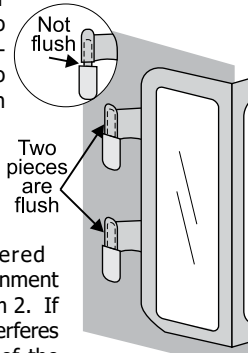

Diagram 1

3) Close the door. The latch plate must be centered around the alignment pin. See diagram 2. If the latch plate interferes with the corner of the stove you may want to angle the plate slightly so the door closes easier.

4) The latches should already be at the proper setting. If they are too hard or too easy to close, you may want to adjust them by loosening the latch catch. See diagram 3.

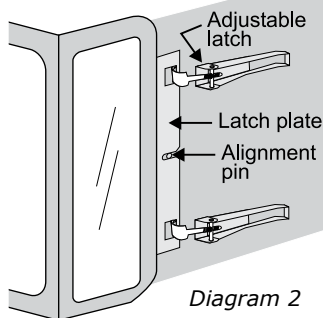

Diagram 2

5) Remove the blue plastic protective coating from the glass.

6) Test the seal around the door by placing a piece of paper between the unit and the door, close the door and try to pull the paper out. If it slips out easily, then the door is not properly sealed.

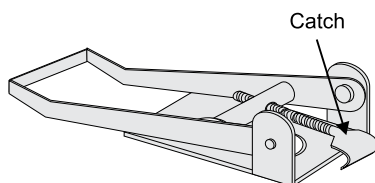

Diagram 3

Tighten or loosen the latch. See diagram 3.

Note: The door latch may require adjustment as the door gasket material compresses after a few fires and after glass replacement. Turn the latch catch inward or outward to loosen or tighten.

Louver Installation

1) Attach the top & bottom louvers to the side stove panel using 2 screws per side.

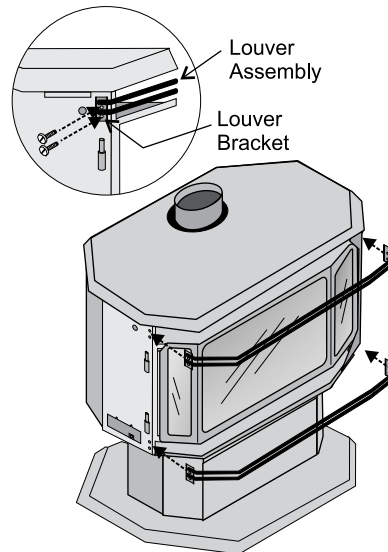

Test for Flue Spillage

A "spillage" test must be made before the installed unit is left with the customer. Follow the procedure below:

1) Start all exhaust fans in the home and any other gas appliances. Then close all doors and windows.

2) Light the unit and set controls to maximum.

3) After five minutes, test that there is a "pull" on the flue by placing a smoke match, cigarette or similar device which gives off smoke, on the edge of the draft hood. See diagrams.

The smoke should be drawn into the draft hood. If the smoke is not drawn into the draft hood, turn the unit off and check for the cause of lack of draft.

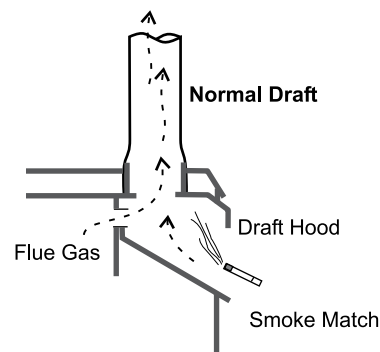

Note: If the flue is blocked or has a strong reverse flow, the thermally actuated safety switch mounted in the draft hood will automatically shut off the gas supply within about 10 minutes. If the heater turns off because of this during the spillage test, check for the cause of the lack of draft.

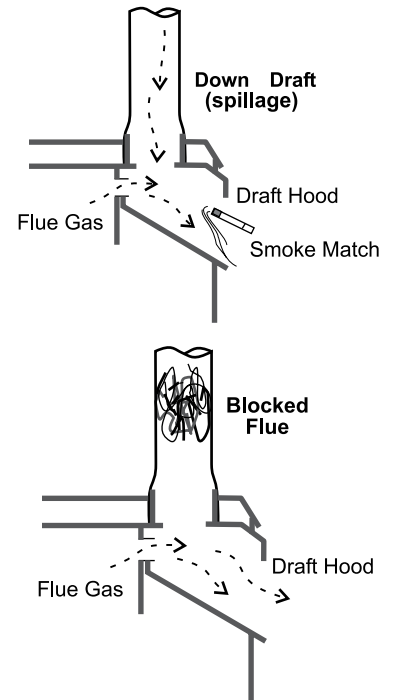

The thermally activated safety switch must be manually reset before first startup.

This switch is located on the right-hand side of the appliance. Open right hand side door; the safety switch will be located directly above the blower. See below.



Location of safety switch. Press red button to reset.

operating instructions

Wiring Diagram without Thermostat

WARNING:
Electrical Grounding
Instructions

This appliance is equipped with a three pronged (grounding) plug for your protection against shock hazard and should be plugged directly into a properly grounded three-prong receptacle. Do not cut or remove the grounding prong from this plug.

This heater does not require a 120V A.C. supply for operation but highly recommended. In case of a power failure, the remote control/thermostat will continue to operate.

Note: The fan does require 120 volt power for it to operate.

Note:
4 AA Batteries must be installed into the back up battery compartment however for this unit to operate when power is lost. See battery back up instructions in this manual The fan will not operate during a power outage.

CAUTION: Ensure that the wires do not touch a hot surface and are away from sharp edges.

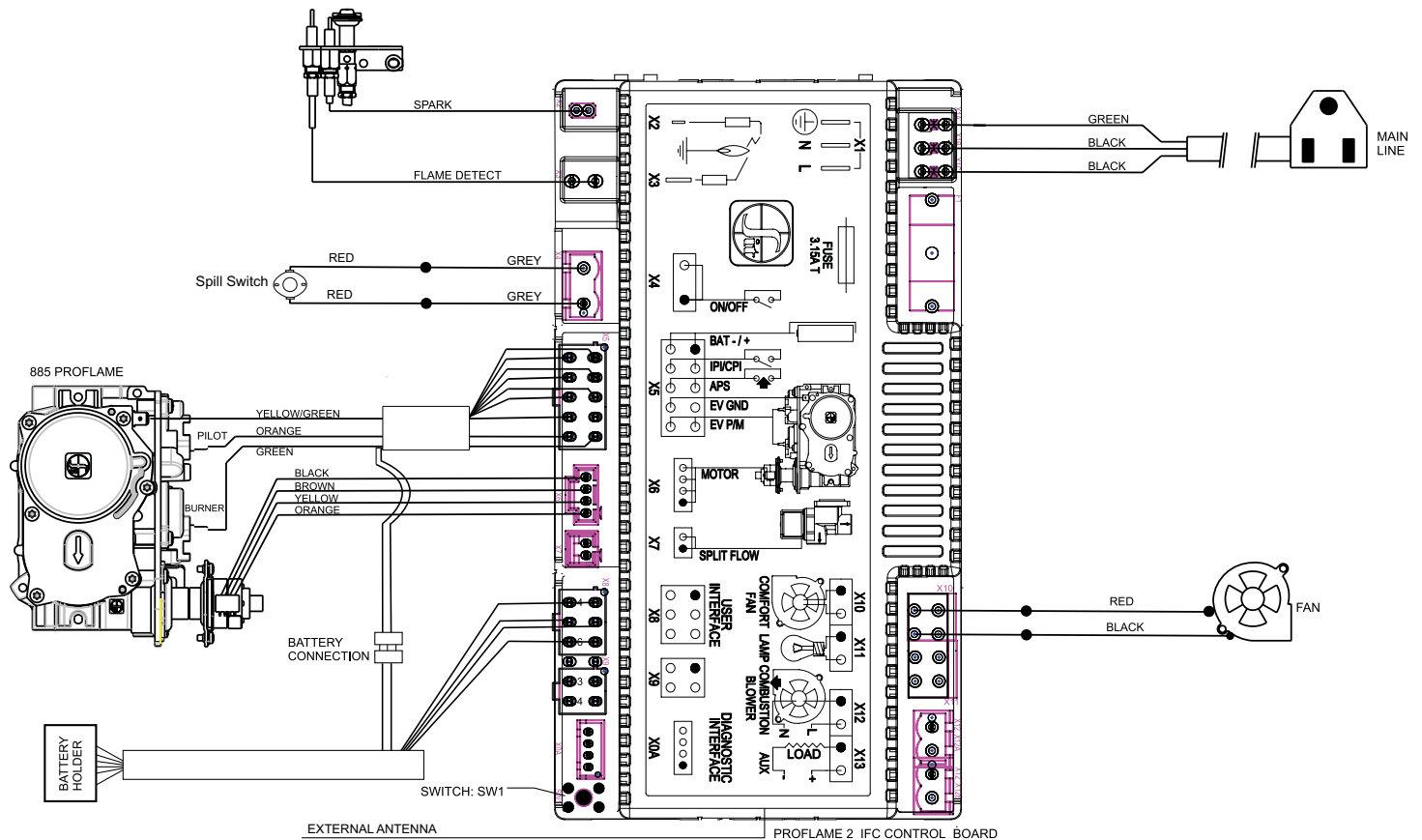

Wiring Diagram with Optional Thermostat

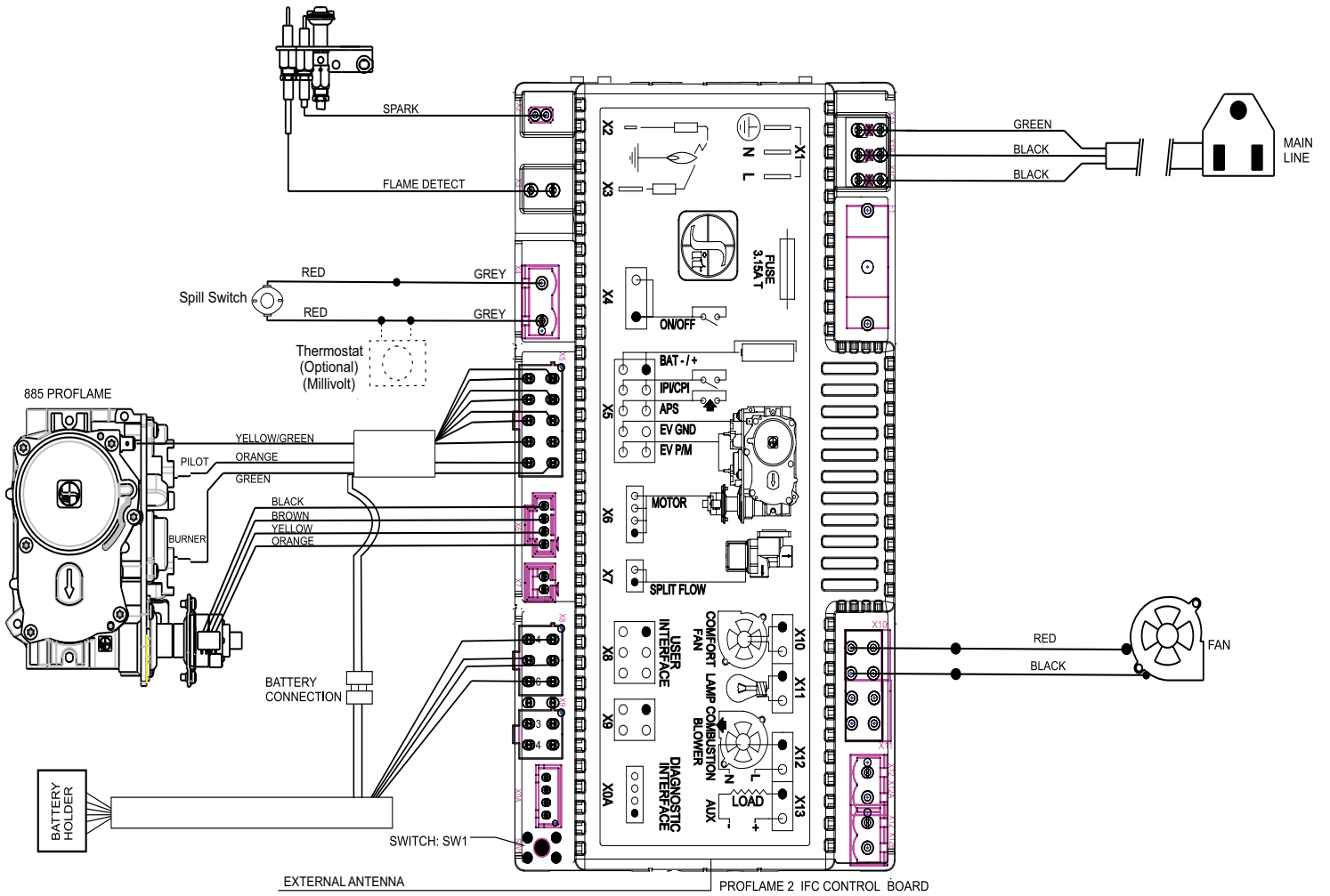

operating instructions

Proflame II Battery Holder Battery Replacement & Battery Pack Up if 120 Volt Power is lost

To operate the stove during a power outage or when power is not available see the following steps.

How to replace/add the batteries on battery holder (Proflame 2).

Note : If a wall switch cover plate is installed, first remove cover plate by removing 2 small phillips head screws

STEP 1

Move both the left/right slides as shown below.

The battery compartment will be pushed out slightly, to allow to easily extract it

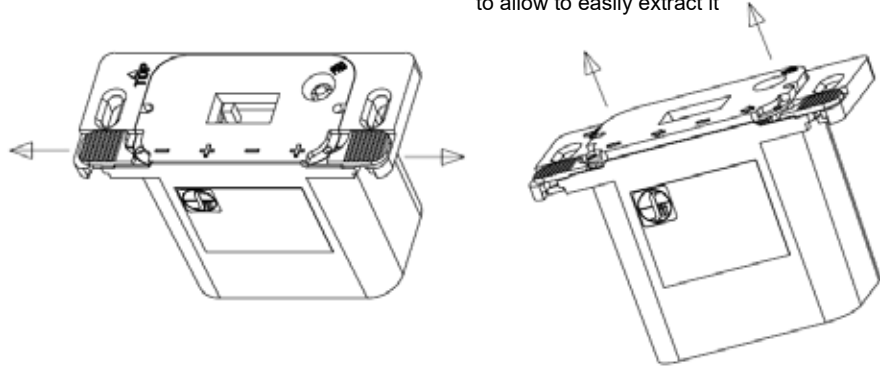

STEP 2

Extract the battery compartment from the remote receiver/battery holder

Replace 4 x AA batteries and insert the battery compartment back into remote receiver/battery holder

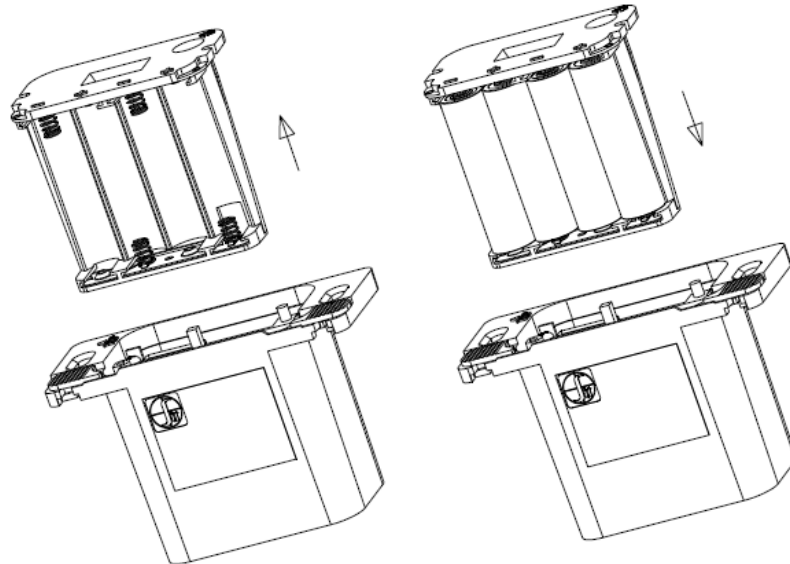

STEP 3

Keeping the battery compartment pressed in, close the left slide

Close the right slide

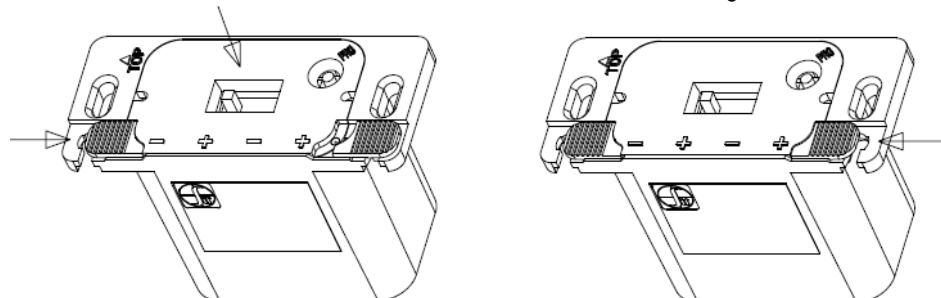

STEP 4 Reinstall wall cover plate with 2 Phillips head screws.

First Fire

The **FIRST FIRE** in your stove is part of the paint curing process. To ensure that the paint is properly cured, it is recommended that you burn your fireplace for at least four (4) hours the first time you use it with the fan on. When first operated, the unit will release an odour caused by the curing of the paint and the burning off of any oils remaining from manufacturing. Smoke detectors in the house may go off at this time. Open a few windows to ventilate the room for a couple of hours. The glass may require cleaning.

DO NOT ATTEMPT TO CLEAN THE GLASS WHILE IT IS STILL HOT!

Note: When the glass is cold and the appliance is lit, it may cause condensation and fog the glass. This condensation is normal and will disappear in a few minutes as the glass heats up.

DO NOT BURN THE APPLIANCE WITHOUT THE GLASS FRONT IN PLACE.

During the first few fires, a white film may develop on the glass front as part of the curing process. The glass should be cleaned or the film will bake on and become very difficult to remove. Use a non-abrasive cleaner and NEVER clean the glass while it is hot.

Operating Instructions

- 1) Read and understand these instructions before operating this appliance.
- 2) Check to see that all wiring is correct and enclosed to prevent possible shock.
- 3) Check to ensure there are no gas leaks.
- 4) Make sure the glass in the door frame is properly positioned. Never operate the appliance with the glass removed. Never strike the glass or slam the door shut.
- 5) Verify that the venting and cap are unobstructed.
- 6) Verify log placement. If the pilot cannot be seen when lighting the unit - the logs have been incorrectly positioned.
- 7) The unit should never be turned off, and on again without a minimum of a 60 second wait. This remote control requires coding. See remote coding instructions for details.

NOTE: This appliance will operate with 4 AA back-up batteries installed (see Back-up Battery section for details) during power outages. Only the fan and light will not operate until power is restored. If the remote is misplaced, the unit can be shut off by flipping the main **ON/OFF** switch, located behind the front cover plate, to the **OFF** position.

IMPORTANT: The remote control system supplied with this appliance has several options for starting/operating the appliance, please read the remote control operating instructions (packed with remote control) to understand how to operate this remote system. You can download remote functions video with the QR code below..

Optional Wall Thermostat

A wall thermostat may be installed if desired. Connect the wires as per the wiring diagrams.

Note: Preferable if the thermostat is installed on an interior wall.

Regency® offers an optional programmable thermostat but any 250-750 millivolt rated non-anticipator type thermostat that is CSA, ULC or UL approved may be used.

CAUTION
Do not connect the wall thermostat wires to the 120V wires.

Operation Using an Optional Wall Thermostat

This appliance ships with a full function remote control as standard equipment. This allows for basic on/off function as well as the ability to operate as a thermostat. With the addition of an optional wall cradle (820-477-AWT available from an authorized dealer) the remote can reside on a wall and carry out all the functions of a typical millivolt wall thermostat as well as being able to control the fan speed, and the flame height. This is the recommended procedure for operating the unit with a thermostatic set point. If a millivolt wall thermostat is required for bedroom installation or as preferred method of controlling the stove, see below.

Wall thermostat and remote. Set the wall thermostat to the desired set point, then place the remote transmitter in either SMART or thermostatic mode with a set point 5 degrees above the set point on the wall thermostat. The burner will fire until the set point on the wall thermostat is satisfied. The remote will remain connected and allow full control of all accessories.

maintenance

Normal Operating Sounds of Gas Appliances

It is possible that you will hear some sounds from your gas appliance. This is perfectly normal due to the fact that there are various gauges and types of steel used within your appliance. Listed below are some examples. All are **normal operating sounds** and should not be considered as defects in your appliance.

Blower:

Hampton® gas appliances use high tech blowers to push heated air farther into the room. It is not unusual for the fan to make a "whirring" sound when ON. This sound will increase or decrease in volume depending on the speed setting of your fan speed control.

Burner Tray:

The burner tray is positioned directly under the burner tube(s) and logs and is made of a different gauge material from the rest of the firebox and body. Therefore, the varying thicknesses of steel will expand and contract at slightly different rates which can cause "ticking" and "cracking" sounds. You should also be aware that as there are temperature changes within the unit these sounds will likely re-occur. Again, this is normal for steel fireboxes.

Pilot Flame:

While the pilot flame is on it can make a very slight "whisper" sound.

Gas Control Valve:

As the gas control valve turns ON and OFF, a dull clicking sound may be audible, this is normal operation of a gas regulator or valve.

Unit Body/Firebox:

Different types and thicknesses of steel will expand and contract at different rates resulting in some "cracking" and "ticking" sounds will be heard throughout the cycling process.

Maintenance Instructions

- 1) Always turn off the valve before cleaning. For relighting, refer to lighting instructions. Keep the burner and control compartment clean by brushing and vacuuming at least once a year. When cleaning the logs, use a soft clean paint brush as the logs are fragile and easily damaged.

- 2) Clean glass (never when unit is hot), appliance, and door with a damp cloth. Never use an abrasive cleaner.

- 3) The heater is finished in a porcelain finish or with a heat resistant paint and should only be refinished with heat resistant paint (not with wall paint).

Never use an abrasive cleaner on the porcelain finish as it may scratch the surface.

- 4) Make a periodic check of burner for proper position and condition. Visually check the flame of the burner periodically, making sure the flames are steady; not lifting or floating. If there is a problem, call a qualified service person.

- 5) **CAUTION:** Label all wires prior to disconnection when servicing controls. Wiring errors can cause improper and dangerous operation.

- 6) The appliance and venting system must be inspected before use, and at least annually, by a qualified field service person, to ensure that the flow of combustion and ventilation air is not obstructed. During the annual service call, the burners should be removed from the burner tray and cleaned. Replace the embers but do not block the pilot.

- 7) Keep the area near the appliance clear and free from combustible materials, gasoline, and other flammable vapours and liquids.

WARNING: CHILDREN AND ADULTS SHOULD BE ALERTED TO THE HAZARDS OF HIGH SURFACE TEMPERATURE AND SHOULD STAY AWAY TO AVOID BURNS OR CLOTHING IGNITION. YOUNG CHILDREN SHOULD BE CAREFULLY SUPERVISED WHEN THEY ARE IN THE SAME ROOM AS THE APPLIANCE.

DO NOT USE THIS APPLIANCE IF ANY PART HAS BEEN UNDER WATER. IMMEDIATELY CALL A QUALIFIED SERVICE TECHNICIAN TO INSPECT THE APPLIANCE AND TO REPLACE ANY PART OF CONTROL SYSTEM AND ANY GAS CONTROL WHICH HAS BEEN UNDER WATER.

CLOTHING OR OTHER FLAMMABLE MATERIAL SHOULD NOT BE PLACED ON OR NEAR THE APPLIANCE.

CAUTION: ANY SAFETY SCREEN OR GUARD REMOVED FOR SERVICING AN APPLIANCE MUST BE REPLACED PRIOR TO OPERATING THE APPLIANCE.

- 8) Each time the appliance is lit, it may cause condensation and fog the glass. This condensation and fog is normal and will disappear in a few minutes as the glass heats up.

Never operate the appliance without the glass properly secured in place.

Flame Pattern

Periodically check the pilot and main burner flames. Correct pilot flame pattern has two strong blue flames: 1 flowing around the flame sensor and 1 flowing across the burner (it does not have to be touching the burner).

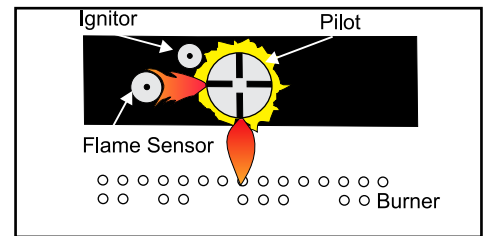

Note: If you have an incorrect flame pattern, contact your Regency® dealer for further instructions.

Incorrect flame pattern will have small, probably yellow flames, not coming into proper contact with the rear burner or flame sensor.

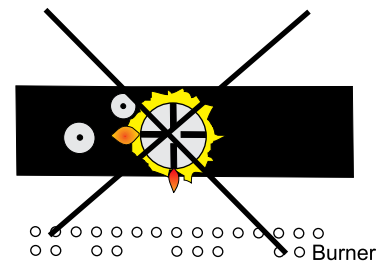

Top View of Pilot Flame

Aeration Adjustment

The burner aeration is factory set but may need adjusting due to either the local gas supply or altitude.

U38E-11 with 38,000 Btu/h

U38E-NG11	Natural Gas:	1/4" open
U38E-LP11	Propane:	1/2" open

U38E-11 with 30,000 Btu/h

U38E-NG11	Natural Gas	3/16" open
U38E-LP11	Propane	3/8" open

The aeration adjustment gears are located on the right side of the burner box and can be accessed from the side or from the front when the louvers are removed.

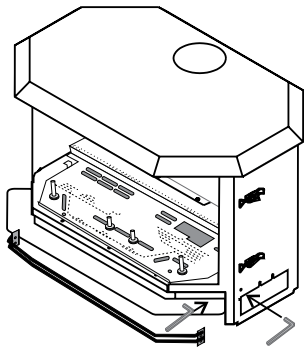

To adjust the aeration: use the allen key to turn the turning gear which will adjust the air shutter. Open the air shutter for a blue flame or close it for a yellower flame.

Closed - Tall yellow flame
Open - Short blue flame

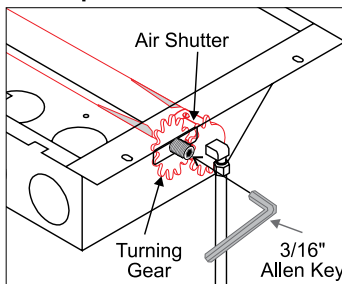

Clockwise to open,
 counter-clockwise to close.

Caution: Carbon will be produced if the air shutter is closed too much.

Note: Any damage due to carboning resulting from improperly setting the aeration controls is NOT covered under warranty.

Note: Aeration Adjustment should only be performed by an authorized Regency® Installer at the time of installation or service.

maintenance

Maintenance Instructions

1) Always shut the valve off before cleaning. For relighting, refer to lighting instructions. Keep the burner and control compartment clean by brushing and vacuuming at least once a year. When cleaning the logs, use a soft clean brush as the logs are fragile and easily damaged.

2) Clean glass (never when unit is hot), appliance, louvers, and door with a damp cloth. Never use an abrasive cleaner. The gold louvers (and optional gold door) may be scratched if abrasives are used to clean them.

The heater is finished in a heat resistant paint and should only be refinished with heat resistant paint (not with wall paint). Regency® uses StoveBright Paint - Metallic Black #6309.

3) Make a periodic check of burner for proper position and condition. Visually check the flame of the burner periodically, making sure the flames are steady; not lifting or floating. If there is a problem, call a qualified service person.

4) The appliance and venting system must be inspected before use, and at least annually, by a qualified field service person, to ensure that the flow of combustion and ventilation air is not obstructed.

During the annual service call, the burners should be removed from the burner tray and cleaned. Replace the embers - do not block the pilot or burner ports.

5) Keep the area near the appliance clear and free from combustible materials, gasoline and other flammable vapours and liquids.

6) Verify proper operation after servicing.

Log Replacement

The unit should never be used with broken logs. Turn off the gas valve and allow the unit to cool before opening door to carefully remove the logs. The pilot light generates enough heat to burn someone. If for any reason a log should need replacement, you must use the proper replacement log. The position of these logs must be as shown in the diagram under Log Installation.

Note: Improper positioning of logs may create carbon build-up and will alter the unit's performance which is not covered under warranty.

Door and Glass Gasket

If the door gasket requires replacement use 7/8" diameter oval door gasket (Part # 732-570). The glass requires 7/8" flat glass gasket. See your Regency® dealer.

Glass Replacement

Your Regency® stove is supplied with high temperature, 5 mm Neoceram ceramic glass that will withstand the highest heat that your unit will produce. In the event that you break your glass, purchase your replacement from an authorized Regency® dealer only, and follow the step-by-step instructions for replacement. **Never operate your unit with broken glass.**

WARNING: Do not operate appliance with the glass front removed, cracked or broken. Replacement of the glass should be done by a licensed or qualified service person.

Panel Door

- 1) Remove the door from the unit and place on a soft surface to prevent scratching.
- 2) Pull out the door gasket.
- 3) Remove the nuts holding the glass retainers in place.
- 4) Remove the glass retainers (sides, top and bottom) and the door catch plate.
- 5) Replace the glass. **The glass must have gasketing around it.**
- 6) Reverse the previous steps, replace the retainers and fasten with the nuts but do not overtighten, as this can break the glass. Note: the door catch plate fits on top of the left side retainer.
- 7) Put gasket glue on the retainers, but do not put glue on the screws. Replace the door gasket, the two ends butt tight together on the bottom edge of the door.
- 8) Replace door on the stove and check the seal.

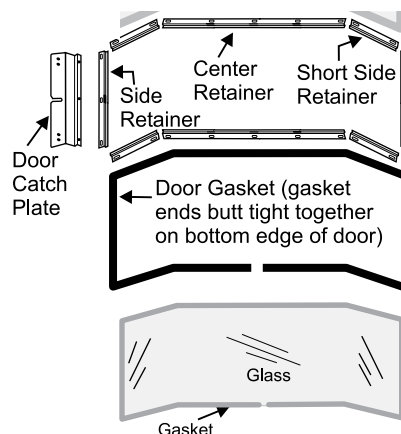

Wraparound Assembly Door

Fan Maintenance

If your fan requires maintenance or replacement, access to the fan is through the access panel on the rear wall of the firebox.

Note: The unit MUST NOT be operated without the fan access panel securely in place and correctly sealed.

IMPORTANT: These fans collect a lot of dust from within your home. Ensure you maintain these fan motors on a regular basis by vacuuming out the fan squirrel cages, around the motor, and around the grills on the back of the stove.

IMPORTANT
Disconnect power supply before servicing

WARNING: Electrical Grounding Instructions This appliance is equipped with a three pronged (grounding) plug for your protection against shock hazard and should be plugged directly into a properly grounded three-prong receptacle. Do not cut or remove the grounding prong from this plug.

To Remove U38E-11 Fan:

- 1) Unplug or disconnect power source to stove.
- 2) Open side door.
- 3) Unclip the black and red wires from the fan motor.
- 4) Lift fan off of the 2 pins, tip back and pull through firebox opening. Disconnect the green ground wire from the left side of the fan as soon as you can reach it.

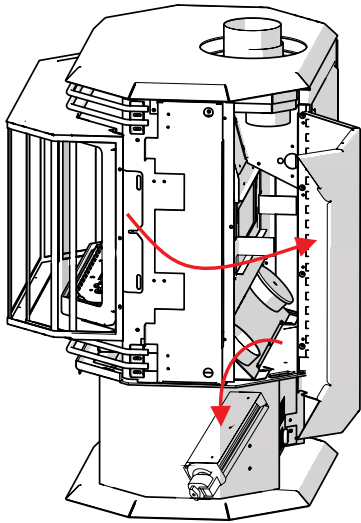

Replacing U38E-11 Fan:

Reverse the above steps (1 - 4).

Tip: When reinstalling fan use dish soap on the rubber grommets. This will eliminate any friction when sliding the fan into position.

Valve Replacement

If your valve requires maintenance or replacement, follow these instructions:

NOTE: Always shut off the gas and electrical supply before removing the valve.

- 1) Remove safety screen and open front pedestal door. You may want to put a soft cloth on the base of the unit so that when the pedestal door is open it doesn't scratch the paint.
- 2) Undo the four screws holding the control panel in place.
- 3) Disconnect all the receiver wires from the back of the panel and then remove panel. You should lay the panel on a soft cloth so it doesn't get marked up.

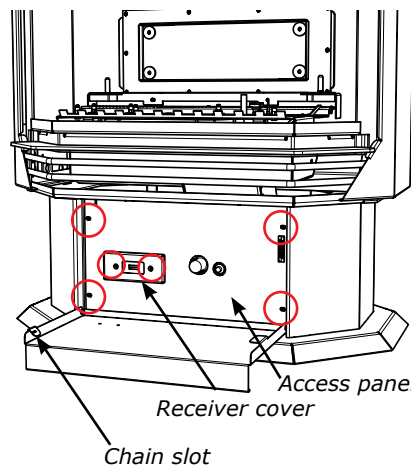

- 4) Disconnect the following wires prior to removing the valve assembly:
 - a) Spark wire from IFC board (x 2)
 - b) Flame detect wire from IFC board (x 3)
 - c) Stepper motor wire harness from IFC board (x 6)
 - d) Orange wire from gas valve (EV 1)
 - e) Green wire from gas valve (EV 2)
 - f) Yellow ground wire found under the location where the orange wire was disconnected on the gas valve.

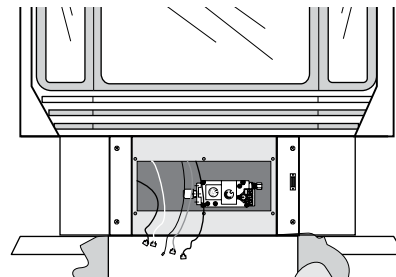

- 5) Carefully remove the logs and lava rock.
- 6) At this point you should disconnect the gas at the valve.

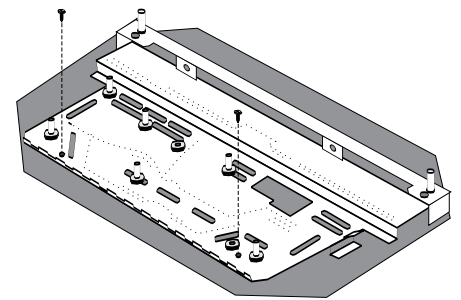

- 7) Remove the burner by removing the two 1/4" hex head screws. See diagram below.

Note: Use a magnetic type screwdriver.

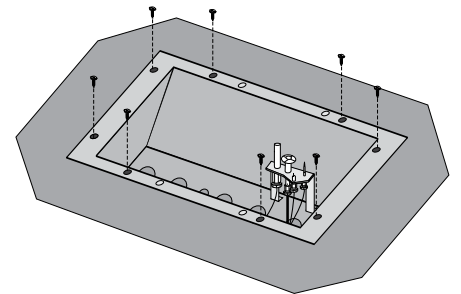

- 8) Remove eight 1/4" hex head screws holding the burner tray assembly in place.

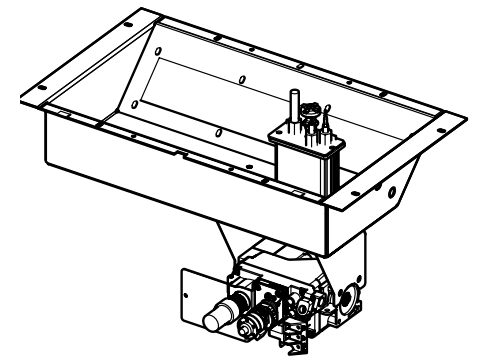

- 9) Carefully lift the burner tray assembly out.
- 10) To replace the burner tray assembly, simply reverse these instructions.

maintenance

Gas Maintenance

In order for your Regency appliance to continue to provide comfort to your home periodic maintenance must be performed to ensure it is operating at peak efficiency. The items in the list should be checked by a licensed gas service technician during the annual service check. Your unit may require more frequent maintenance checks if you notice any changes in how it operates. Operational changes to look for can include, but are not limited to, extended start up time, increased fan noise, residue/carbon build up, white build up on the glass/firebox, increased operating noise etc. Should any of these or other conditions arise, discontinue use and schedule a service check with your local licensed gas technician. The list below shows items your licensed service technician will need to check and service at least annually.

Clean

- Glass
- Interior bricks / panels
- Burner ports & burner air shutter
- Fan blades
- Log set
- Pilot orifices
- Pilot hood (change as needed)
- Flame sensor (electronic ignition models)
- Flame electrode
- Burner orifice
- Thermocouple (millivolt models)
- Thermopile (millivolt models)

Inspect

- Pilot assembly
- Burner
- Pressure relief gaskets/doors
- Flue connector gasket if present
- Door seal
- Firebox
- Venting
- Batteries (remote handheld, remote receiver, DC sparker, change as needed)
- Burner media (change as needed)
- Air shutter setting
- Wiring

Check

- Voltage on thermocouple/thermopile (millivolt models)
- Ohms reading on flame sense (electronic ignition models)
- Inlet/outlet fuel pressures as per rating plate
- Voltage/ohms readings on gas valve
- Ohms reading to on/off switch circuit (Millivolt models)

Gas Leak Tests

- Check main gas line connection to valve
- Check shut off valve connections
- Check connection at gas valve outlet
- Check connection at main burner orifice
- Check pilot fuel line at valve and at pilot assembly

U38E-11 Main Assembly

Part #	Description	Part #	Description
1)	732-929 Safety Screen	30)	750-026 Rear Panel
2)	560-921 Top/Bottom Brush Nickel Louver Assy (Optional)	32)	730-565 Firebox Baffle
	560-922 Top/Bottom Black Louver Assy (Optional)	33)	560-535 False Top Assembly
9)	560-055 Fan Access Door	34)	590-273 Flue Attachment Bracket
10)	730-034 Gasket for Fan Access Door	35)	590-930 Ult. 6" Flue Collar (Optional)
	730-517/P Fan Assembly	38)	820-058 Pedestal Base Cover
11)	910-331/P Fan Motor (120 Volt)		948-223 Logo Plate
12)	911-179 Power Cord IFC Proflame II (120 Volt)		919-973 Manual
15)	* Pedestal Assembly		
16)	730-039 Pedestal Door		
17)	904-257 Pedestal Door Magnet		
18)	732-084 Pedestal Back		
19)	733-011 Front Control Panel Plate		
20)	730-531 Short Side Panel Door Assy (each)		
21)	560-031 Hinge for Side Panel (each)		
23)	904-258 Side Panel Door Magnet (each)		
24)	948-255 Door Latch c/w Hook (each)		

*Not available as a replacement part.

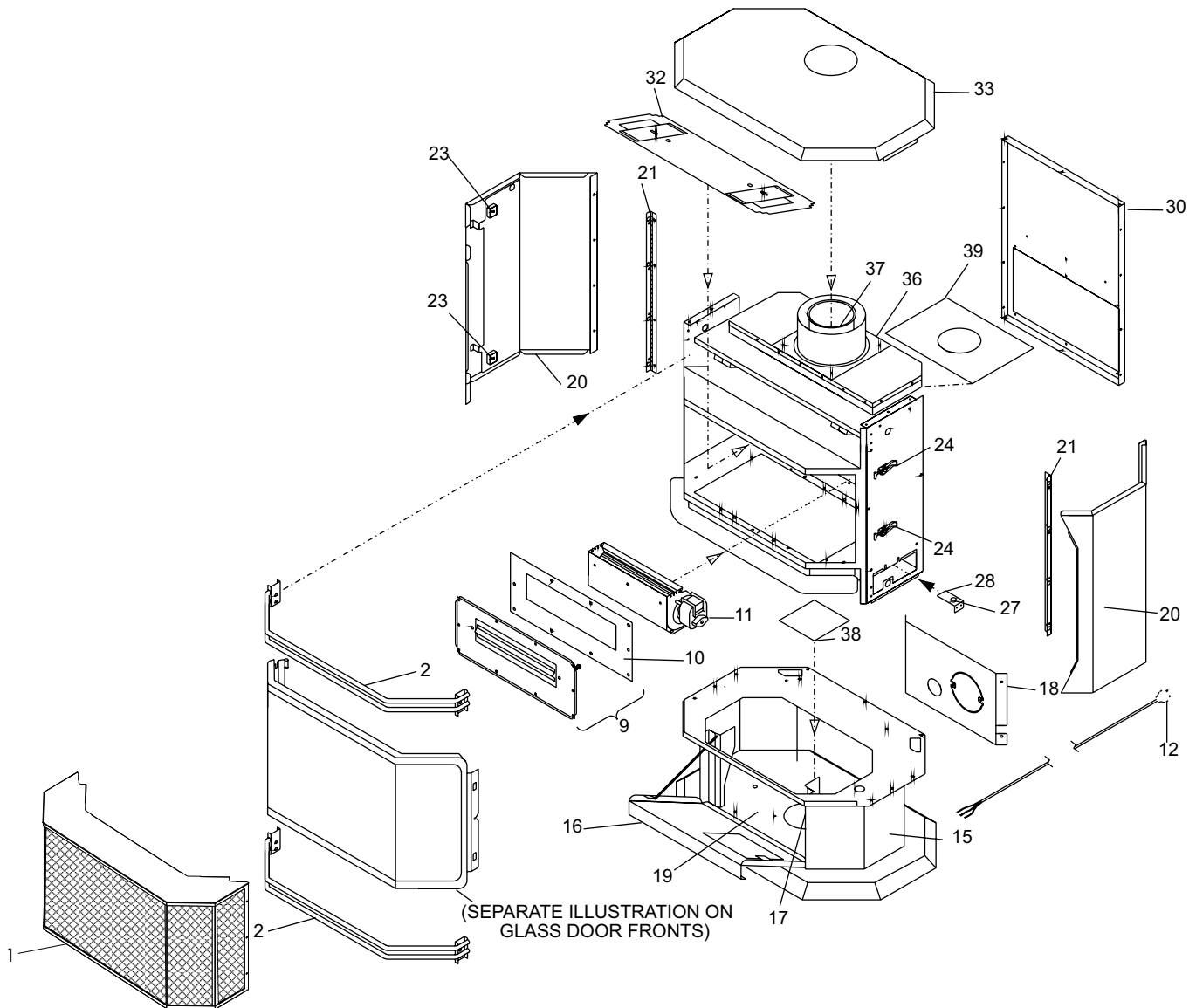

parts list

U38E-11 Burner & Log Assembly

Part #	Description	Part #	Description
59.	753-774/P Valve Assembly- Natural Gas 753-776/P Valve Assembly - Propane	910-250	Spill Switch - Manual Reset
60.	911-084 Valve NG 885 SIT IPI 0.885.001 911-085 Valve LP 885 SIT IPI 0.885.002	910-705	Wire High Temp - Valve End
66.	911-284 Pilot Assy IPI NG 2 Flame 0.199.050911-006 911-285 Pilot Assy IPI LP 2 Flame	910-749	Wire Thermodisc To Switch
67.	904-688 #32 Orifice - N.G. at 38,000 Btu/h 904-240 #37 Orifice - N.G. at 30,000 Btu/h 904-689 #33 Orifice - N.G. at 35,000 Btu/h 904-390 #52 Orifice - Propane at 30,000 Btu/h 904-641 #50 Orifice - Propane at 38,000 Btu/h 936-170 Orifice Gasket	910-802	Wire SIT Valve To Burner On/Off
71.	732-514 Rear Log Bracket	911-173	Wire Harness IFC No CPI Switch 584.924
75.	732-930 Log Set Complete - Oak 732-931 Log Set Complete - Driftwood 902-058 Lave (Bag) 946-669 Platinum Embers (Bag) 946-708 Embaglow Embers (Bag)	911-178	Wire 2 Pos IFC Burner On/Off
78.	737-550 Burner Assembly (NG/LP)	911-257	Wire 2 Pos IFC Fan
80.	260-565 Air Shutter Gear Assembly - Female	911-266/P	IFC Board SIT Profm II 7day PV+5 Sec.FFRT 0.584.625
81.	904-565 Hex Key 3/16" AF	911-210	Antenna IFC Shielded Harness 315MHz
84.	* Air Shutter Gear Assembly - Male	911-282	Wire Harness Battery Box Proflame II .584.922
85.	911-010 Stepper Motor NG For 885/886 SIT 0.907.013 911-011 Stepper Motor LP For 885/886 SIT 0.907.012 911-337/P Remote Battery Compartment 911-175 Remote handheld (GTMF) 910-036 Pilot Orifice LP #51 0.977.165 910-037 Pilot Orifice NG #30 0.977.167 911-039 Pilot Hood	911-342	Black Battery Cover Plate With Switch Black 0.584.801
	753-977 Conversion Kit LP 911-093 120 Volt Power Cord (10 foot extension) 911-137 Pilot Clip	100.	911-037 Flame sensor
		101.	911-038 Flame Electrode
		102.	910-432 Pilot Tube with Nuts

*Not available as a replacement part.

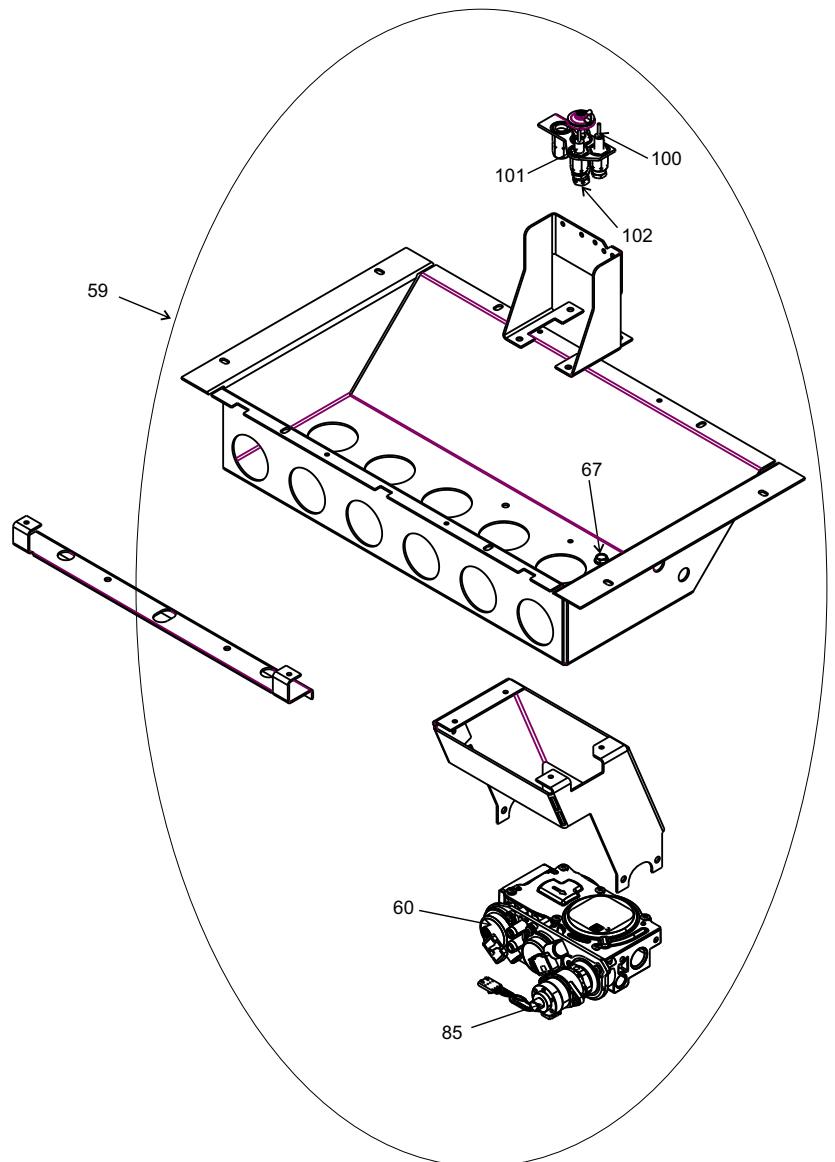

U38E-11 Door Assembly

Part #	Description
732-943	Black Wrap Door - Complete
732-944	Brushed Nickel Wrap Door - Complete
101) 732-570	Door Gasket Kit
105) *	Ceramic Paper
107) 936-243	Glass Gasket
111) *	Door Frame Fibre Paper
208) 940-325/P	Wrap Glass
209) 732-020	Door Mounting Bracket

*Not available as a replacement part.

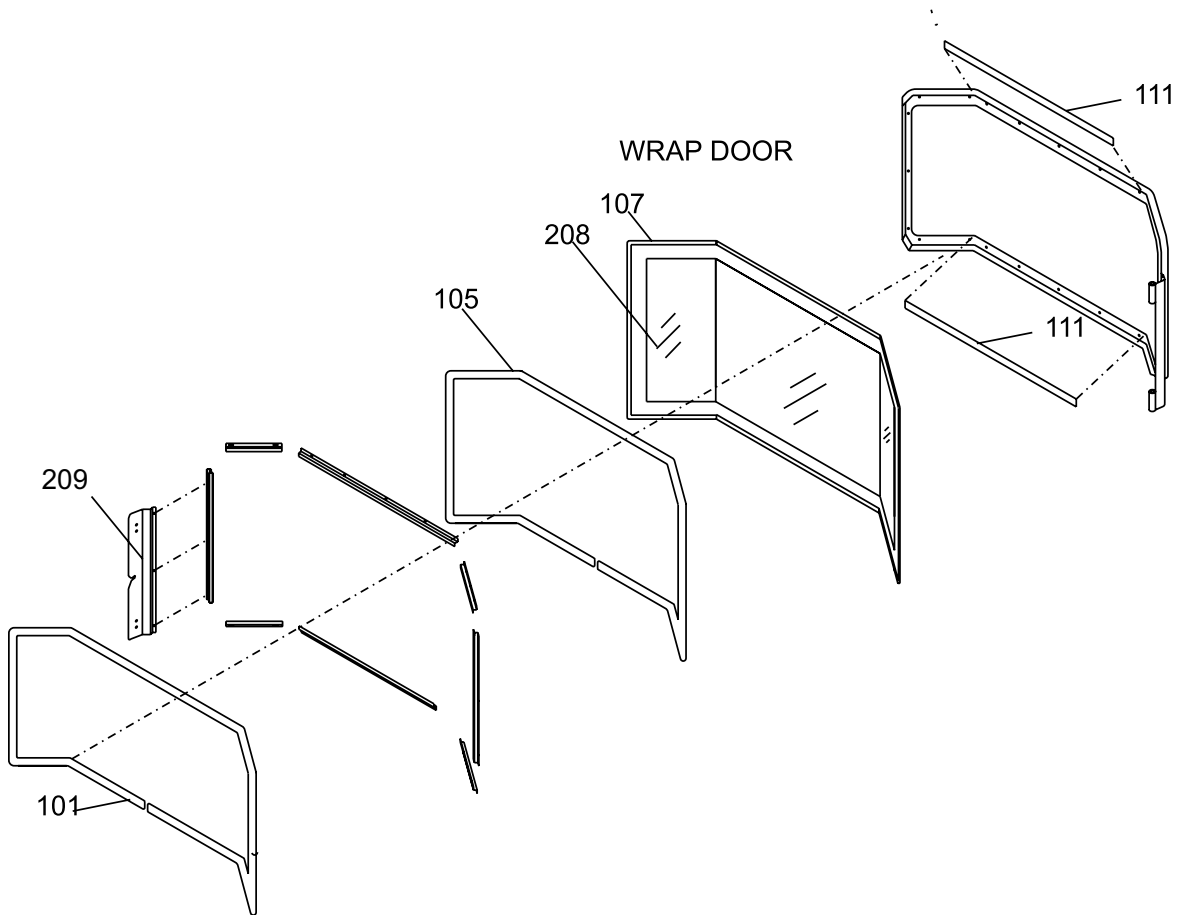

warranty

Limited Lifetime Warranty

FPI Fireplace Products International Ltd. (for Canadian customers) and Fireplace Products U.S., Inc. (for U.S. customers) (collectively referred to herein as “FPI”) extends this Limited Lifetime Warranty to the original purchaser of this appliance provided the product remains in the original place of installation. The items covered by this limited warranty and the period of such coverage is set forth in the table below.

Some conditions apply (see below).

The policy is not transferable, amendable or negotiable under any circumstances.

Indoor Gas Products Warranty Coverage Parts and Labor	Part				Supplier	Labor Coverage
	Lifetime	5 years	2 years	1 year	Warranty	(Years)
Firebox and Heat Exchanger	✓					3
Steel Burner Tube	✓					3
Glass Thermal breakage only	✓					3
All Surrounds/Inlays Finishes		✓				3
Brick Panels/Log sets/Ceramic Burners		✓				3
All Castings		✓				3
Valve assembly and all gas control components, (Pilot assembly, flame sensors, Spark Electrode, Pilot Tubing, Orifices, Thermocouple, Thermopile)			✓			2
All Other Electrical components, (Ignition Control Boards, Wiring, Switches, Blowers, Blower Control Module, Battery Pack, Remote Control Systems)			✓			2
Enamel Panels			✓			1
Venting/Venting Components			✓			1
All Stainless steel surrounds				✓		1
All Firebox Media (Crystals, Firebeads, Volcanic, Ceramic & Spa Stones)				✓		1
All hardware				✓		1
Mesh/Glass Safety Barriers				✓		1
Accent Light Bulbs				✓		1
Glass (Crazing)				✓		1

Conditions:

Warranty protects against defect in manufacture or FPI factory assembled components only, unless herein specified otherwise.

Any part(s) found to be defective during the warranty period as outlined above will be repaired or replaced at FPI’s option through an accredited distributor, dealer or pre-approved and assigned agent provided that the defective part is returned to the distributor, dealer or agent for inspection if requested by FPI. Alternatively, FPI may at its own discretion fully discharge all of its obligations under the warranty by refunding the verified purchase price of the product to the original purchaser. The purchase price must be confirmed by the original Bill of Sale.

The authorized selling dealer, or an alternative authorized FPI dealer if pre-approved by FPI, is responsible for all in-field diagnosis and service work related to all warranty claims. FPI is not responsible for results or costs of workmanship of unauthorized FPI dealers or agents in the negligence of their service work.

At all times FPI reserves the right to inspect reported complaints on location in the field claimed to be defective prior to processing or authorizing of any claim. Failure to allow this upon request will void the warranty.

All warranty claims must be submitted by the dealer servicing the claim, including a copy of the Bill of Sale (proof of purchase by you). All claims must be complete and provide full details as requested by FPI to receive consideration for evaluation. Incomplete claims may be rejected.

Unit must be installed according to all manufacturers' instructions as per the manual.

All Local and National required codes must be met.

The installer is responsible to ensure the unit is operating as designed at the time of installation.

The original purchaser is responsible for annual maintenance of the unit, as outlined in the owner's manual. As outlined below, the warranty may be voided due to problems caused by lack of maintenance.

Repair/replacement parts purchased by the consumer from FPI after the original coverage has expired on the unit will carry a 90 day warranty, valid with a receipt only. Any item shown to be defective will be repaired or replaced at our discretion. No labor coverage is included with these parts

Exclusions:

This Limited Lifetime Warranty does not extend to paint, rust or corrosion of any kind due to a lack of maintenance or improper venting, combustion air provision, corrosive chemicals (i.e. chlorine, salt, air, etc.), door or glass gasketing.

Malfunction, damage or performance based issues as a result of environmental conditions, location, chemical damages, downdrafts, installation error, installation by an unqualified installer, incorrect chimney components (including but not limited to cap size or type), operator error, abuse, misuse, use of improper fuels, lack of regular maintenance and upkeep, acts of God, weather related problems from hurricanes, tornados, earthquakes, floods, lightning strikes/bolts or acts of terrorism or war, which result in malfunction of the appliance are not covered under the terms of this Limited Lifetime Warranty.

FPI has no obligation to enhance or modify any unit once manufactured (i.e. as products evolve, field modifications or upgrades will not be performed on existing appliances).

This warranty does not cover dealer travel costs for diagnostic or service work. All labor rates paid to authorized dealers are subsidized, pre-determined rates. Dealers may charge homeowner for travel and additional time beyond their subsidy.

Any unit showing signs of neglect or misuse will not be covered under the terms of this warranty policy and may void this warranty. This includes units with rusted or corroded fireboxes which have not been reported as rusted or corroded within three (3) months of installation/purchase.

Units which show evidence of being operated while damaged, or with problems known to the purchaser and causing further damages will void this warranty.

Units where the serial no. has been altered, deleted, removed or made illegible will void this warranty.

Minor movement, expansion and contraction of the steel is normal and is not covered under the terms of this warranty.

FPI is not liable for the removal or replacement of facings or finishing in order to repair or replace any appliance in the field.

Freight damages for products or parts are not covered under the terms of the warranty.

Products made or provided by other manufacturers and used in conjunction with the FPI appliance without prior authorization from FPI may void this warranty.

warranty

Limitations of Liability:

The original purchaser's exclusive remedy under this warranty, and FPI's sole obligation under this warranty, express or implied, in contract or in tort, shall be limited to replacement, repair, or refund, as outlined above. IN NO EVENT WILL FPI BE LIABLE UNDER THIS WARRANTY FOR ANY INCIDENTAL OR CONSEQUENTIAL COMMERCIAL DAMAGES OR DAMAGES TO PROPERTY. TO THE EXTENT PERMITTED BY APPLICABLE LAW, FPI MAKES NO EXPRESS WARRANTIES OTHER THAN THE WARRANTY SPECIFIED HEREIN. THE DURATION OF ANY IMPLIED WARRANTY IS LIMITED TO DURATION OF THE EXPRESSED WARRANTY SPECIFIED ABOVE. IF IMPLIED WARRANTIES CANNOT BE DISCLAIMED, THEN SUCH WARRANTIES ARE LIMITED IN DURATION TO THE DURATION OF THIS WARRANTY.

Some U.S. states do not allow limitations on how long an implied warranty lasts, or allow exclusion or limitation of incidental or consequential damages, so the above limitations or exclusions may not apply to you.

Customers located outside the U.S. should consult their local, provincial or national legal codes for additional terms which may be applicable to this warranty.

How to Obtain Warranty Service:

Customers should contact the authorized selling dealer to obtain warranty service. In the event the authorized selling dealer is unable to provide warranty service, please contact FPI by mail at the address listed below. Please include a brief description of the problem and your address, email and telephone contact information. A representative will contact you to make arrangements for an inspection and/or warranty service.

Canadian Warrantor:

FPI Fireplace Products International Ltd.
6988 Venture St.
Delta, British Columbia
Canada, V4G 1H4

U.S. Warrantor:

Fireplace Products U.S., Inc.
PO Box 2189 PMB 125
Blaine, WA
United States, 98231

Or contact the Regency Customer Care Centre at 1-800-442-7432 (phone) / 604-946-4349 (fax)

Product Registration and Customer Support:

Thank you for choosing a Regency Fireplace. Regency strives to be a world leader in the design, manufacture, and marketing of hearth products. To provide the best support for your product, we request that you complete a product registration form at <http://www.regency-fire.com/Customer-Care/Warranty-Registration.aspx> within ninety (90) days of purchase.



Product Registration and Customer Support:

Thank you for choosing a Regency Fireplace. Regency strives to be a world leader in the design, manufacture, and marketing of hearth products. To provide the best support for your product, we request that you complete a product registration form found on our Web Site under Customer Care within ninety (90) days of purchase.

For purchases made in **CANADA or the UNITED STATES:**

<http://www.regency-fire.com/Customer-Care/Warranty-Registration.aspx>

For purchases made in AUSTRALIA:

<http://www.regency-fire.com.au/Customer-Care/Warranty-Registration.aspx>

You may also complete the warranty registration form below to register your Regency Fireplace Product and mail and/or fax it back to us, and we will register the warranty for you. It is important you provide us with all the information below in order for us to serve you better.

Warranty Registration Form (or Register online immediately at the above Web Site):

Warranty Details	
Serial Number (required):	
Purchase Date (required) (mm/dd/yyyy):	
Product Details	
Product Model (required):	
Dealer Details	
Dealer Name (required):	
Dealer Address:	
Dealer Phone #:	
Installer:	
Date Installed (mm/dd/yyyy):	
Your Contact Details (required)	
Name:	
Address:	
Phone:	
Email:	

For purchases made in CANADA:

**FPI Fireplace Products
International Ltd.**
6988 Venture St.
Delta, British Columbia
Canada, V4G 1H4

Phone: 604-946-5155
Fax: 1-866-393-2806

For purchases made in the UNITED STATES:

Fireplace Products US, Inc.
PO Box 2189 PMB 125
Blaine, WA
United States, 98231

Phone: 604-946-5155
Fax: 1-866-393-2806

For purchases made in AUSTRALIA:

Fireplace Products Australia Pty Ltd
99 Colemans Road
Dandenong South, Vic. 3175
Australia

Phone: +61 3 9799 7277
Fax: +61 3 9799 7822

For fireplace care and tips and answers to most common questions please visit our Customer Care section on our Web Site. Please feel free to contact your selling dealer if you have any questions about your Regency product.

warranty

Installer: Please complete the following information

Dealer Name & Address: _____

Installer: _____

Phone #: _____

Date Installed: _____

Serial #: _____



U38-39 Video