



# Energy™ E18E Gas Insert

## Owners & Installation Manual



[www.regency-fire.com](http://www.regency-fire.com)

MODELS: E18E-NG11 Natural Gas E18E-LP11 Propane

**▲ WARNING**  
**FIRE OR EXPLOSION HAZARD**  
Failure to follow safety warnings exactly could result in serious injury, death, or property damage.

- Do not store or use gasoline or other flammable vapors and liquids in the vicinity of this or any other appliance.

**- WHAT TO DO IF YOU SMELL GAS**

- Do not try to light any appliance.
- Do not touch any electrical switch: do not use any phone in your building. Leave the building immediately.
- Immediately call your gas supplier from a neighbour's phone. Follow the gas supplier's instructions.
- If you cannot reach your gas supplier, call the fire department.

- Installation and service must be performed by a qualified installer, service agency or the gas supplier.

Tested by:



Certified to/Certifié pour: CSA 2.17-2017  
ANSI Z21.88-2019  
CSA 2.33-2019

**Installer:** Please complete the details on the back cover and leave this manual with the homeowner.  
**Homeowner:** Please keep these instructions for future reference.

# CONGRATULATIONS!

You are the owner of a state-of-the-art Gas Insert by:  
**FPI FIREPLACE PRODUCTS INTERNATIONAL LTD.**

**The Regency® Gas Fireplace Series** has been designed to provide you with all the warmth and charm of a fireplace, at the flick of a switch. The models E18E-NG and E18E-LP of this series have been approved by Intertek/Warnock Hersey for safety. As it also bears our own mark, it promises to provide you with economy, comfort and security for many trouble free years to follow. Please take a moment now to acquaint yourself with these instructions and the many features of your Regency® Fireplace.



# DANGER

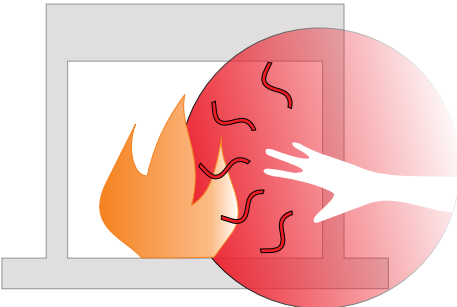

**HOT GLASS WILL  
CAUSE BURNS**

**DO NOT TOUCH GLASS  
UNTIL COOLED**

**NEVER ALLOW CHILDREN  
TO TOUCH GLASS**

A barrier designed to reduce the risk of burns from the hot viewing glass is provided with this appliance and must be installed for the protection of children and other at risk individuals.

## CAUTION:

**HOT WHILE IN OPERATION. DO NOT TOUCH.  
SEVERE BURNS MAY RESULT. KEEP CHILDREN, CLOTHING, FURNITURE,  
GASOLINE, AND ANY OTHER LIQUIDS WITH FLAMMABLE VAPOURS AWAY.**

**KEEP BURNER AND CONTROL COMPARTMENT CLEAN.  
SEE INSTALLATION AND OPERATING INSTRUCTIONS ACCOMPANYING  
APPLIANCE.**

920-408



**NATIONAL  
FIREPLACE  
INSTITUTE**  
**NFI**  
**CERTIFIED**  
www.nficertified.org

We recommend that our products be installed and serviced by professionals who are certified in the U.S. by the National Fireplace Institute® (NFI) or in Canada by Wood Energy Technical Training (WETT).



**Wood Energy  
Technical Training**  
www.wett.org

**UNIT DIMENSIONS**

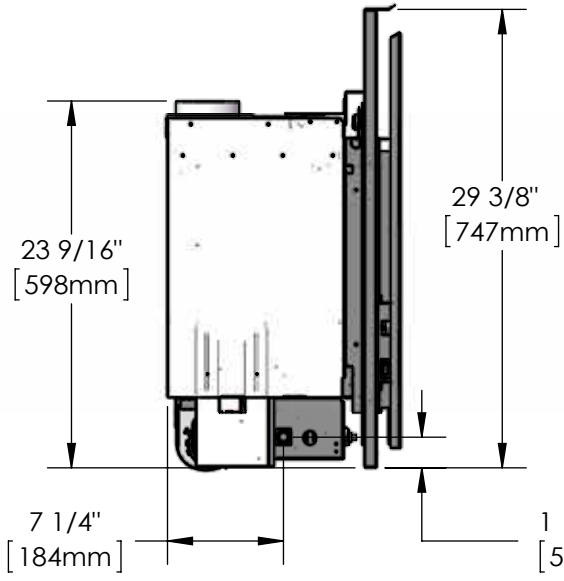
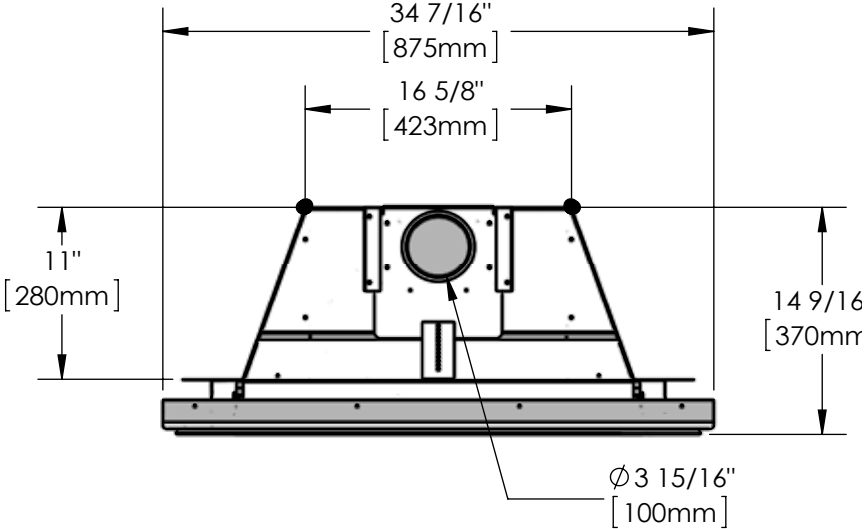
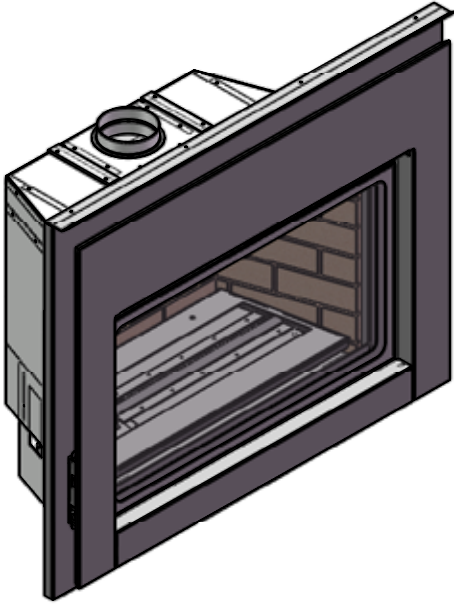

**Diagram 1.1**

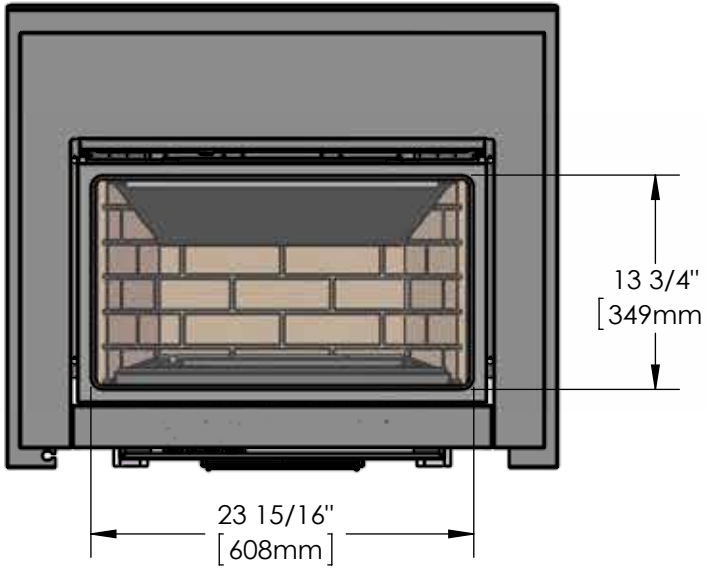

*616-924 -- Low Profile Faceplate shown*

**Overall Faceplate Dimensions:**

- 616-920 - Low Profile Faceplate (Firesong FS220N) 35 5/8" wide x 29 5/8" High
- 616-921 - Low Profile Faceplate (Montigo 28F/28F-2/28F-3) 34 1/4" Wide x 28 1/2" High
- 616-924 - Low Profile Faceplate (Montigo EP28-4/EP28-5/EconoPlus 28C) 34 7/16" wide X 29 3/8" High
- 616-926 - Low Profile Faceplate (Montigo 36SR) 34 3/8" Wide X 27 1/4" High
- 616-928 - Low Profile Faceplate (Firesong FS120N) 32 5/8" Wide X 28 1/4" High
- 617-948 - Low Profile Faceplate Zero Clearance Applications 34 7/8" Wide X 29 3/8" High

NOTE: also includes a perimeter finishing trim 37 3/8" Wide X 32 1/4" High

# table of contents

## owner's information

Unit Dimensions .....	3
On Demand Pilot Light (seven day safety timer) .....	5
Before You Start.....	9
Important Message .....	9
General Safety Information .....	9
Lighting Procedure .....	11
Copy of Lighting Plate Instructions .....	12
Optional Proflame I Remote Control Operating Instructions .	13

<b>Warranty .....</b>	<b>64</b>
-----------------------	-----------

## installer's information

Gas Installation Checklist .....	7
Installation Guidelines .....	17
Gas Connection .....	17
Pilot Adjustment.....	18
886 S.I.T. Valve Description.....	18
Gas Pipe Pressure Testing .....	18
High Elevation.....	18
Installation Checklist.....	19
Materials Required.....	19
Venting.....	19
Venting Configurations.....	19
Minimum Fireplace Clearances to Combustibles .....	20
Zero Clearance Framing Dimensions .....	21
Zero Clearance Framing .....	22

## Installation

Zero Clearance Faceplate Installation .....	25
Optional Wall Thermostat .....	30
Optional Remote Control.....	30
Optional Wall Switch.....	30
AC Power Adaptor Installation (for SureFire Systems) .....	31
Optional GTM Remote Installation .....	32
Conversion Kit 617-977 - Natural Gas to Propane.....	34
Glass Burner Installation / Removal .....	35
Enamel Panel Installation.....	36
Glass Crystals and Optional Ceramic Spa or Volcanic Stones Installation On Burner and Firebox Floor .....	37
Optional Spa or Volcanic Stones Installation (around burner) .....	37
Brick Panel Installation .....	38
Log Tray Installation.....	39
Log Set Installation .....	39
Optional Log Set Installation .....	41
Glass Door / Screen Installation / Removal.....	43
Safety Screen Replacement.....	43
Draft Hood Check .....	44
Safety Switches.....	45
Operation Controls .....	45
Fireplace Controls.....	45
Copy of the Lighting Plate Instructions.....	46

## Operation

Operating Instructions .....	47
First Fire.....	47
Adjustment.....	47

## Maintenance

Maintenance Instructions .....	48
First Fire.....	48
Normal Operating Sounds of Gas Appliances .....	48
Log Replacement .....	49
Valve Replacement.....	50
Installing Valve.....	50
Removing the Fan .....	51
Wiring Diagrams .....	52
Gas Maintenance - Recommended Annual Routine.....	54

## Part Lists

Main Assembly .....	55
EP28 Installation Kit .....	57
Montigo Econo Plus 28C Installation Kit .....	58
Montigo 28F & 28F-2 Installation Kit.....	59
Montigo 28F-3 Installation Kit.....	60
Montigo 36SR Installation Kit .....	61
Firesong 220N Installation Kit.....	62
Firesong 120N Installation Kit.....	63

## Warranty

Warranty .....	64
Recycling .....	70

This is a copy of the label that accompanies each Regency® Gas Insert. We have printed a copy of the contents here for your review. The safety label is located on the front inside base of the unit visible when the bottom louver is open.

**Note: Regency® units are constantly being improved. Check the label on the unit and if there is a difference, the label on the unit is the correct one.**

**Please note that with the addition of thermostat control and outside combustion air supply, this unit is approved for bedroom installations.**

For the State of Massachusetts, installation and repair must be done by a plumber or gasfitter licensed in the Commonwealth of Massachusetts.

For the State of Massachusetts, flexible connectors shall not exceed 36 inches in length.

For the State of Massachusetts, the appliances individual manual shut-off must be a t-handle type valve.

The State of Massachusetts requires the installation of a carbon monoxide alarm in accordance with NFPA 720 and a CO alarm with battery back up in the same room where the gas appliance is installed.

**ON DEMAND PILOT LIGHT (SEVEN DAY SAFETY TIMER)**

Important information if using the appliance in CPI (continuous pilot mode) only. This appliance is a ProFlame 1 system fitted with the "On Demand" Pilot, a safety feature which will shut down the gas valve completely by extinguishing the pilot light in the event of a continuous full seven days of inactivity. This only applies if the CPI (continuous pilot) switch is in the "on" position. Each time the main burner shuts down, manually or through the call from the thermostat, the seven day timer starts again. The seven day inactivity timer is controlled within the circuit board. Therefore, if in CPI mode and when the pilot light is extinguished after seven straight days of inactivity, the IPI/CPI rocker switch will remain in the "on" position. Therefore, all that is required to relight the pilot would be to press the on/off button on the remote control transmitter from "on" to "off" and back to "on". Once the pilot has re-established operation will resume as normal. There is no requirement to do anything with the IPI/CPI rocker switch. If the unit never goes as long as seven full days without a call for heat, the pilot will remain lit until it is manually shut-off. If the unit is being operated in IPI (intermittent pilot) mode, neither the above instructions nor the seven day timer will apply. See the instructions in this manual and on the Lighting Instructions plate on the appliance to light or re-light the pilot.

500

Duplicate Serial number

---

500



**Intertek**  
C #: 4001172

Serial No. / No de série  
**Listed/Nom: VENTED GAS FIREPLACE /  
FOYER AU GAZ À ÉVACUATION**  
**Certified to/Certifié : CSA 2.17-2017**  
ANSI Z21.88:2019 • CSA-2.33:2019

MAY BE INSTALLED IN MANUFACTURED (MOBILE) HOMES AFTER FIRST SALE.  
Refer to Intertek's Directory of Building Products for detailed information.  
Pour plus de détails, se reporter au Répertoire des produits de construction de Intertek.

**NATURAL GAS FIREPLACE INSERT: MODEL E18E-NG11**  
**Factory Equipped For Altitude 0-4500ft. (0-1370m)**

Min. supply pressure	5"	WC	(1.25kPa)
Low Setting Man. pressure	1.6"	WC	(0.40kPa)
Max. Manifold pressure	3.5"	WC	(0.87kPa)
Orifice size	44	DMS	(2.64mm)
Minimum input	15,000	Btu/h	(4.40kW)
Altitude	0-4500ft		(0-610m)
Maximum input	21,600	Btu/h	(6.33kW)

**PROPANE FIREPLACE INSERT: MODEL E18E-LP11**  
**Factory Equipped For Altitude 0-4500ft. (0-1370m)**

Min. supply pressure	11"	WC	(2.74 kPa)
Low Setting Man. pressure	6.4"	WC	(1.59 kPa)
Max. Manifold pressure	10"	WC	(2.49 kPa)
Orifice size	55	DMS	(1.6mm)
Minimum input	17,000	Btu/h	(4.98kW)
Altitude	0-4500ft		(0-610m)
Maximum input	20,500	Btu/h	(6.01kW)

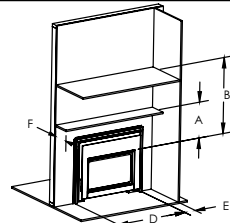

**Minimum Clearances to Combustibles:**  
**Dégagements minimaux par rapport aux matériaux combustibles :**

Min. Mantel Height A	17-7/8"(453mm)
Min. Ceiling Height B	37-7/8"(961mm)
D	37-1/2"(953mm)
Side wall E	6" (152mm)
Max. Mantel Depth F	9" (229mm)



This appliance must be installed in accordance with local codes, if any; if none, follow the National Fuel Gas Code, ANSI Z223.1, or Natural Gas and Propane Installation Code, CSA B149.1.  
**WARNING:** This fireplace has been converted for use with a gas fireplace insert only and cannot be used for burning wood or solid fuels unless all original parts have been replaced, and the fireplace re-approved by the authority having jurisdiction.  
 Cet appareil doit être installé selon les codes et règlements locaux, ou, en leur absence, se conformer au National Fuel Gas Code, ANSI Z223.1, ou au Natural Gas and Propane Installation Code, CSAB149.1.  
**AVERTISSEMENT :** Ce foyer a été converti pour utilisation avec un foyer au gaz encastrable et ne peut être utilisé pour brûler du bois ou d'autres combustibles solides à moins que toutes les pièces d'origine aient été remplacées et que le foyer ait été approuvé de nouveau par l'autorité compétente.  
**This vented gas fireplace heater is not for use with air filters.**  
**Ne pas utiliser de filtre à air avec ce foyer au gaz à évacuation.**  
 For use with glass doors certified with the appliance only  
 Pour utilisation uniquement avec les portes en verre certifiées avec l'appareil

**VENTED GAS FIREPLACE HEATER - NOT FOR USE WITH SOLID FUELS. CATEGORY I**  
**FOYER AU GAZ À ÉVACUATION - NE PAS UTILISER AVEC UN COMBUSTIBLE SOLIDE. CATÉGORIE I**

Electrical supply / Alimentation électrique 115VAC, 2.5 A, 60Hz, Less than / Moins de 10A Fan Part # 911-071 / Pièce du ventilateur n° 911-071  
**For Use Only with Barrier (Part #616-929)**  
**Utiliser uniquement avec l'écran (n°616-929)**  
 FPI Fireplace Products International Ltd. Delta BC, CANADA  
**MADE IN CANADA / FABRIQUÉ AU CANADA**



CANADIAN ENERGY PERFORMANCE VERIFIED  
RENDÉMENT ÉNERGÉTIQUE VÉRIFIÉ

CSA P.4.1 Fireplace Efficiency (FE) / Efficacité énergétique des foyers (EEF) CSA P.4.1  
Natural Gas / Gaz naturel 69.42%  
Propane Gas / Gaz propane 71.42%

919-998b

# requirements

## MA Code - CO Detector (for the State of Massachusetts only)

### 5.08: Modifications to NFPA-54, Chapter 10

(2) Revise 10.8.3 by adding the following additional requirements:

(a) For all side wall horizontally vented gas fueled equipment installed in every dwelling, building or structure used in whole or in part for residential purposes, including those owned or operated by the Commonwealth and where the side wall exhaust vent termination is less than seven (7) feet above finished grade in the area of the venting, including but not limited to decks and porches, the following requirements shall be satisfied:

1. INSTALLATION OF CARBON MONOXIDE DETECTORS. At the time of installation of the side wall horizontal vented gas fueled equipment, the installing plumber or gasfitter shall observe that a hard wired carbon monoxide detector with an alarm and battery back-up is installed on the floor level where the gas equipment is to be installed. In addition, the installing plumber or gasfitter shall observe that a battery operated or hard wired carbon monoxide detector with an alarm is installed on each additional level of the dwelling, building or structure served by the side wall horizontal vented gas fueled equipment. It shall be the responsibility of the property owner to secure the services of qualified licensed professionals for the installation of hard wired carbon monoxide detectors

a. In the event that the side wall horizontally vented gas fueled equipment is installed in a crawl space or an attic, the hard wired carbon monoxide detector with alarm and battery back-up may be installed on the next adjacent floor level.

b. In the event that the requirements of this subdivision can not be met at the time of completion of installation, the owner shall have a period of thirty (30) days to comply with the above requirements; provided, however, that during said thirty (30) day period, a battery operated carbon monoxide detector with an alarm shall be installed.

2. APPROVED CARBON MONOXIDE DETECTORS. Each carbon monoxide detector as required in accordance with the above provisions shall comply with NFPA 720 and be ANSI/UL 2034 listed and IAS certified.

3. SIGNAGE. A metal or plastic identification plate shall be permanently mounted to the exterior of the building at a minimum height of eight (8) feet above grade directly in line with the exhaust vent terminal for the horizontally vented gas fueled heating appliance or equipment. The sign shall read, in print size no less than one-half (1/2) inch in size, "**GAS VENT DIRECTLY BELOW. KEEP CLEAR OF ALL OBSTRUCTIONS**".

4. INSPECTION. The state or local gas inspector of the side wall horizontally vented gas fueled equipment shall not approve the installation unless, upon inspection, the inspector observes carbon monoxide detectors and signage installed in accordance with the provisions of 248 CMR 5.08(2)(a)1 through 4.

(b) EXEMPTIONS: The following equipment is exempt from 248 CMR 5.08(2)(a)1 through 4:

1. The equipment listed in Chapter 10 entitled "Equipment Not Required To Be Vented" in the most current edition of NFPA 54 as adopted by the Board; and

2. Product Approved side wall horizontally vented gas fueled equipment installed in a room or structure separate from the dwelling, building or structure used in whole or in part for residential purposes.

(c) MANUFACTURER REQUIREMENTS - GAS EQUIPMENT VENTING SYSTEM PROVIDED. When the manufacturer of Product Approved side wall horizontally vented gas equipment provides a venting system design or venting system components with the equipment, the instructions provided by the manufacturer for installation of the equipment and the venting system shall include:

1. Detailed instructions for the installation of the venting system design or the venting system components; and

2. A complete parts list for the venting system design or venting system.

(d) MANUFACTURER REQUIREMENTS - GAS EQUIPMENT VENTING SYSTEM NOT PROVIDED. When the manufacturer of a Product Approved side wall horizontally vented gas fueled equipment does not provide the parts for venting the flue gases, but identifies "special venting systems", the following requirements shall be satisfied by the manufacturer:

1. The referenced "special venting system" instructions shall be included with the appliance or equipment installation instructions; and

2. The "special venting systems" shall be Product Approved by the Board, and the instructions for that system shall include a parts list and detailed installation instructions.

(e) A copy of all installation instructions for all Product Approved side wall horizontally vented gas fueled equipment, all venting instructions, all parts lists for venting instructions, and/or all venting design instructions shall remain with the appliance or equipment at the completion of the installation.

## GAS INSTALLATION CHECKLIST

This general checklist does not contain all pertinent installation details or specifics and does not supersede the guidelines in this manual. Your Regency dealer/installer should use it in conjunction with manual instructions. Please follow all local codes and jurisdictions in authority.

<b>Customer:</b> _____	<b>Date Installed:</b> _____
<b>Install Address:</b> _____	<b>Location of Fireplace:</b> _____
<b>Serial No:</b> _____	<b>Installer:</b> _____
<b>Model No:</b> _____	

<b>Site Requirements</b>	<b>YES</b>	<b>NO</b>
If applicable, are the insulation, vapour barrier, and drywall present if installed on an outside wall or chase?		
Does the area have a solid continuous base to support the unit?		
Will the area accommodate the size of the appliance and all clearances?		
Are the gas and electrical roughed into the area where the unit is being installed?		
In City & Grandview series cool wall applications, is the chase enclosure sealed to prevent heat from escaping? All hot air from the unit must exit via the mandatory ventilation openings.		
In City & Grandview applications, Is the chase enclosure vented with the mandatory heat ventilation openings? See manual for details.		
If applicable, is the masonry/factory built freplace in its original condition with no modifications?		
If applicable, have the hearth requirements been met?		
<b>Unit Setup</b>	<b>YES</b>	<b>NO</b>
If applicable, are the standoffs and top nailing flange extensions installed and at the correct depth to accommodate finishing material? See manual for details.		
If applicable, is the fireplace level and secured, meeting framing clearances? See manual for details.		
If applicable, is the unit converted to top or rear vent per manual instructions, and the insulation discarded?		
<b>Venting</b>	<b>YES</b>	<b>NO</b>
Are the venting components approved for the unit installed?		
Does the venting configuration comply with venting diagrams?		
Is venting installed and secured, and are clearances for the vent pipe and termination cap maintained?		
If applicable, was a 1/4" rise maintained for every foot of horizontal run?		
Was the termination installed and sealed?		
Is the direct vent termination at the highest point in the vent assembly?		
If applicable, are both chimney liners continuous from flue collars to termination?		
<b>Electrical and Wiring</b>	<b>YES</b>	<b>NO</b>
Is the appliance connected to the household's 110/120v per local codes? Check local codes for receptacle placement.		
Were the connections in the fireplace tested with a circuit tester?		
Is the appliance properly grounded?		
If applicable, is the supplied electrical/gang box affixed to the wall to facilitate the mounting of the receiver/battery box ?		
If applicable, is all electrical, Ethernet, HDMI, networking, optical, wire/cables, conduits, etc. run through the wood or steel stud work as wires/cables of any kind cannot be exposed directly above or over the fireplace?		
<b>Gas</b>	<b>YES</b>	<b>NO</b>
Does the supply pressure meet the requirements shown on the rating plate?		
Was a conversion performed?		
Was a leak check performed and manifold pressures verified?		

# installation

Is the shut-off valve installed and easily accessible to the customer?		
<b>Finishing</b>	<b>YES</b>	<b>NO</b>
If applicable, is only noncombustible material installed in the noncombustible areas?		
Do clearances meet installation and manual requirements?		
Do the mantels and/or projections comply with the installation manual?		
If applicable, was the solid fuel fireplace warning plate installed?		
Is the chase enclosure fully open the full width, height and depth above the fireplace as per the requirements noted in the framing section?		
<b>Appliance Media Setup</b>	<b>YES</b>	<b>NO</b>
Do commands from the remote or wall switch light the pilot and main burner?		
Are the burner media/log set, glass door, and screen installed per instructions in the manual?		
Was the air shutter on the proper setting after running the unit for 20 minutes?		
If applicable, were the surround and trims installed according to the manual?		
Was the operation of the fan, lights (if installed), and flame modulation checked?		
<b>Customer Tutorial and Presentation</b>	<b>YES</b>	<b>NO</b>
Is the customer confident operating the new gas appliance and aware of all the features on the remote?		
Confirm that the rating and lighting plates are attached to the appliance. Do not remove.		
Was the customer informed of the location of the rating and lighting plates?		
Was accessing unit controls in a power outage explained to the customer?		
Are the model and serial numbers and the date of installation of the unit written in the manual and on the checklist?		
Were the warranty and unit registration reviewed with the customer?		
<b>Comments:</b>		



## BEFORE YOU START

Safe installation and operation of this appliance requires common sense, however, we are required by the Canadian Safety Standards and ANSI Standards to make you aware of the following:

**INSTALLATION AND REPAIR SHOULD BE DONE BY AN AUTHORIZED SERVICE PERSON. THE APPLIANCE SHOULD BE INSPECTED BEFORE USE AND AT LEAST ANNUALLY BY A PROFESSIONAL SERVICE PERSON. MORE FREQUENT CLEANING MAY BE REQUIRED DUE TO EXCESSIVE LINT FROM CARPETING, BEDDING MATERIAL, ETC. IT IS IMPERATIVE THAT CONTROL COMPARTMENTS, BURNERS AND CIRCULATING AIR PASSAGEWAYS OF THE APPLIANCE BE KEPT CLEAN.**

**DUE TO HIGH TEMPERATURES, THE APPLIANCE SHOULD BE LOCATED OUT OF TRAFFIC AND AWAY FROM FURNITURE AND DRAPERIES.**

**WARNING: FAILURE TO INSTALL THIS APPLIANCE CORRECTLY WILL VOID YOUR WARRANTY AND MAY CAUSE A SERIOUS HOUSE FIRE.**

**CHILDREN AND ADULTS SHOULD BE ALERTED TO THE HAZARDS OF HIGH SURFACE TEMPERATURES, ESPECIALLY THE FIREPLACE GLASS, AND SHOULD STAY AWAY TO AVOID BURNS OR CLOTHING IGNITION.**



**YOUNG CHILDREN SHOULD BE CAREFULLY SUPERVISED WHEN THEY ARE IN THE SAME AREA AS THE APPLIANCE. TODDLERS, YOUNG CHILDREN AND OTHERS MAY BE SUSCEPTIBLE TO ACCIDENTAL CONTACT BURNS. A PHYSICAL BARRIERS IS RECOMMENDED IF THERE ARE AT RISK INDIVIDUAL IN THE HOUSE. TO RESTRICT ACCESS TO A FIREPLACE OR STOVE, INSTALL AN ADJUSTABLE SAFETY GATE TO KEEP TODDLERS, YOUNG CHILDREN AND OTHER AT RISK INDIVIDUALS OUT OF THE ROOM AND AWAY FROM HOT SURFACES.**

**CLOTHING OR OTHER FLAMMABLE MATERIAL SHOULD NOT BE PLACED ON OR NEAR THE APPLIANCE.**

**A BARRIER DESIGNED TO REDUCE THE RISK OF BURNS FROM THE HOT VIEWING GLASS IS PROVIDED WITH THIS APPLIANCE AND SHALL BE INSTALLED FOR THE PROTECTION OF CHILDREN AND OTHER AT-RISK INDIVIDUALS.**

**IF THE BARRIER BECOMES DAMAGED, THE BARRIER SHALL BE REPLACED WITH THE MANUFACTURER'S BARRIER FOR THIS APPLIANCE.**

**ANY SAFETY SCREEN, GUARD, OR BARRIER REMOVED FOR SERVICING AN APPLIANCE MUST BE REPLACED PRIOR TO OPERATING THE APPLIANCE.**

## IMPORTANT MESSAGE SAVE THESE INSTRUCTIONS

The Regency® Gas Fireplace must be installed in accordance with these instructions. Carefully read all the instructions in this manual first. Consult the "authority having jurisdiction" to determine the need for a permit prior to starting the installation. It is the responsibility of the installer to ensure this fireplace is installed in compliance with the manufacturer's instructions and all applicable codes.

## GENERAL SAFETY INFORMATION

The condition of the appliance, that the E18E is to be installed into, shall be in accordance with reasonable concepts of safety, substantiality and durability. Component parts shall be well fitted and not show signs of becoming warped, bent, broken or otherwise damaged during the installation. Every part of the appliance shall be secured against displacement and constructed to maintain a fixed relationship between essential parts under normal and reasonable conditions of handling and usage.

- The appliance installation must conform with local codes or, in the absence of local codes, with the current Canadian or National Gas Codes, CSA B149.1 or ANSI Z223.1 Installation Codes.
- The appliance when installed, must be electrically grounded in accordance with local codes, or in the absence of local codes with the current National Electrical Code, ANSI/NFPA 70 or CSA C22.1 Canadian Electrical Code.
- See general construction and assembly instructions. The appliance and vent should be enclosed.
- This appliance must be connected to the specified vent and termination cap to the outside of the building envelope. Never vent to another room or inside a building. Make sure that the vent is installed as per Venting instructions.
- This appliance may only be installed in an approved zero clearance gas appliances listed in this manual, or as a zero clearance appliance.
- This appliance is Listed for bedroom installations when used with a Listed Millivolt Thermostat. Outside combustion air supply is also required. Some areas may have further requirements, check local codes before installation.
- This appliance is Listed for Alcove installations, maintain minimum Alcove clearances as follows, minimum ceiling height of 37'-7/8" from the top of the glass door, minimum width of 49" and a maximum depth of 29".
- Inspect the venting system annually for blockage and any signs of deterioration.
- Any safety glass removed for servicing must be replaced prior to operating the appliance.
- To prevent injury, do not allow anyone who is unfamiliar with the operation to use the fireplace insert.
- Wear gloves and safety glasses for protection while doing required maintenance.
- Ensure adequate combustion and ventilation air.
- Under no circumstances should this appliance be modified. Parts that have to be removed for servicing should be replaced prior to operating this appliance.
- Installation and any repairs to this appliance should be done by a qualified service person. A professional service person should be called to inspect this appliance annually. Make it a practice to have all of your gas appliances checked annually.
- Unit is not designed to be installed with a power vent system.



**WARNING: Cancer and Reproductive Harm**  
www.P65Warnings.ca.gov

919-874

## owner's information

17. Under no circumstances should any solid fuels (wood, paper, cardboard, coal, etc.) be used in this appliance.
18. The appliance area must be kept clear and free of combustible materials, (gases and other flammable vapours and liquids).
19. Do not use this appliance if any part has been under water. Immediately call a qualified service technician to inspect the appliance and to replace any part of the electrical control system and any gas control which has been under water.
20. **WARNING: Failure to position the parts in accordance with the diagrams in this manual or failure to use only parts specifically approved with this appliance may result in property damage or personal injury.**
21. **WARNING: Operation of this appliance when not connected to a properly installed and maintained venting system or tampering with the blocked vent shut-off system can result in carbon monoxide (CO) poisoning and possible death.**
22. All original vent systems must be inspected for carbon/soot build up prior to installation of the E18E. The installer should also ensure prior to installation that the existing vent system is adequate for the rated input of this appliance (21,600 BTU NG/20,500 BTU LP).

Signs of white buildup (aldehydes) in the vent system would indicate that the appliance was not drafting properly due to vent height, diameter of vent, excessive offsets, negative pressure, kinks, etc.

Adhere to the local gas code within your jurisdiction for vent sizing.

Any venting system that causes the Regency E18E to not function as it should is not the responsibility of the manufacturer.

## LIGHTING PROCEDURE

**IMPORTANT:** The optional remote control system has several options for starting/operating the appliance using the power button and ON/OFF key on the hand held transmitter.

Prior to operating this appliance, please read the remote control operating instructions (packaged with remote control) to understand how to operate this remote control system. Option to download remote functions video with QR code below.



Proflame video

1. Ensure the wall switch/receiver is in the remote position. (see Diagram 1).

Set Switch to Remote

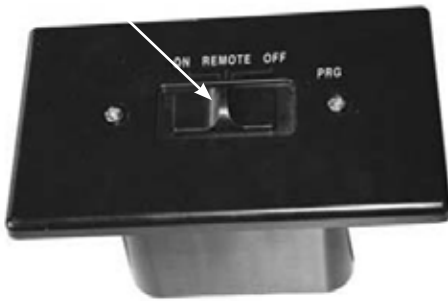

Diagram 1

2. Press and release the ON/OFF button on the remote handheld transmitter (see Diagram 2). An audible beep should be heard from the receiver.



Diagram 2

Remote shown in Manual Mode on Hi

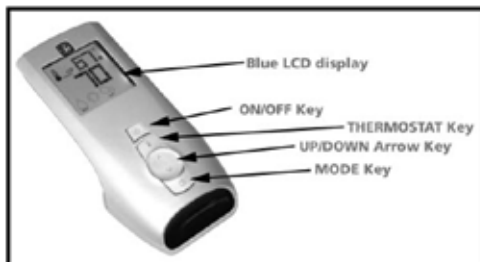

3. After approximately 4 seconds the spark ignition system will spark for 60 seconds to light the main burner.

4. The unit will turn on.

**Note:** The first try for ignition will last approximately 60 seconds. If there is no flame ignition (rectification) the board will stop sparking for approximately 35 seconds. After wait time, the board will start second try for ignition by sparking for approximately 60 seconds. If there is still no positive ignition the board will go into lock out.

The system will need to be reset as follows:

- a) Turn the system off using ON/OFF switch or press ON/OFF button - if using remote.
- b) After approximately 2 seconds turn on ON/OFF switch or press ON/OFF button if using remote.
- c) Repeat step 2.

## SHUTDOWN PROCEDURE

1. Turn the wall mounted switch or remote to the "OFF" position.
2. Press "OFF" on the remote control.
3. Turn the gas control knob to the "OFF" position to turn off the pilot.

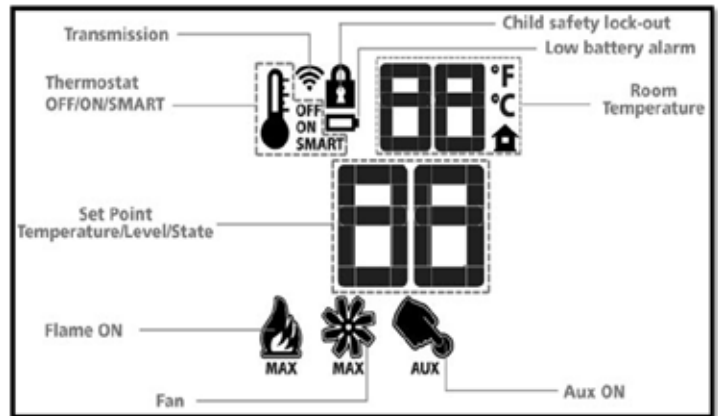

## COPY OF LIGHTING PLATE INSTRUCTIONS

**FOR YOUR SAFETY READ BEFORE LIGHTING  
POUR VOTRE SÉCURITÉ – À LIRE AVANT LA MISE EN MARCHÉ**

**WARNING:** If you do not follow these instructions exactly, a fire or explosion may result causing property damage, personal injury or loss of life. Improper installation, adjustment, alteration, service or maintenance can cause injury or property damage. Refer to the owner's information manual provided with this appliance. For assistance or additional information consult a qualified installer, service agency or gas supplier.

**AVERTISSEMENT :** Quiconque ne respecte pas scrupuleusement les instructions de la présente notice risque de déclencher un incendie ou une explosion pouvant entraîner des dégâts matériels ou des blessures pouvant être mortelles. Tout défaut d'installation, de réglage, de modification, de service ou d'entretien peut entraîner des blessures ou des dommages matériels. Reportez-vous au manuel d'utilisation fourni avec cet équipement. Pour obtenir de l'aide ou des informations complémentaires, consulter un installateur ou un service d'entretien qualifié, ou le fournisseur de gaz.

- A) This appliance is equipped with an ignition device which automatically lights the pilot.  
Do not try to light the pilot by hand.
- B) **BEFORE OPERATING** smell all around the appliance area for gas. Be sure to smell next to the floor because some gas is heavier than air and will settle on the floor.
- WHAT TO DO IF YOU SMELL GAS**
- Do not try to light any appliance.
  - Do not touch any electric switch, do not use any phone in your building.
  - Leave the building immediately.
  - Immediately call your gas supplier from a neighbours phone. Follow the gas supplier's instructions.
  - If you cannot reach your gas supplier, call the fire department.
- C) Do not use this appliance if any part has been under water. Immediately call a qualified service technician to inspect the appliance and to replace any part of the control system and any gas control which has been underwater.
- A) Cet appareil est muni d'un dispositif d'allumage qui allume automatiquement la veilleuse.  
Ne tentez pas d'allumer la veilleuse manuellement.
- B) **AVANT LA MISE EN MARCHÉ**, reniflez tout autour de l'appareil pour déceler une odeur de gaz. Reniflez au niveau du plancher, car certains gaz sont plus lourds que l'air et peuvent s'accumuler au niveau du sol.
- QUE FAIRE SI VOUS SENTEZ UNE ODEUR DE GAZ :**
- Ne tentez pas d'allumer l'appareil
  - Ne touchez à aucun interrupteur; n'utilisez pas le téléphone se trouvant dans le bâtiment.
  - Quittez immédiatement le bâtiment.
  - Appelez immédiatement votre fournisseur de gaz depuis un téléphone extérieur. Suivez les instructions du fournisseur.
  - Si vous ne pouvez pas rejoindre le fournisseur, appelez le service incendie.
- C) N'utilisez pas cet appareil s'il a été plongé dans l'eau, même partiellement. Faites inspecter l'appareil par un technicien qualifié et remplacez tout élément du système de contrôle ou de commande qui a été plongé dans l'eau.

**CAUTION:** Hot while in operation. Do not touch. Severe burns may result. Due to high surface temperatures keep children, clothing and furniture, gasoline and other liquids having flammable vapors away. Keep burner and control compartment clean. See installation and operating instructions accompanying appliance.

**ATTENTION :** Surfaces chaudes lorsque l'appareil est en marche. Ne pas toucher. Risque de brûlures graves. En raison des températures élevées, les enfants, les vêtements et le mobilier, le carburant et tout autre liquide aux vapeurs inflammables doivent être tenus éloignés de l'appareil. Nettoyer régulièrement le brûleur et le compartiment des commandes. Voir les consignes d'installation et d'utilisation fournies avec l'appareil.

**OPERATING INSTRUCTIONS / CONSIGNES DE FONCTIONNEMENT**

- 1) **STOP!** Read the safety information above on this label.
  - 2) Ensure the Main switch is in the ON position and/or the wall mounted battery holder (if equipped) is in the <REMOTE> position.
  - 3) Press and release the ON/OFF button on the remote handheld transmitter. An audible beep should be heard from the receiver. If not using the remote, the unit can also be turned on by sliding the battery holder switch to the <ON> position (if equipped).
  - 4) After approximately 4 seconds the spark ignition system will spark for 60 seconds to light the main burner.
  - 5) The unit will turn on.
- Note: The first attempt to ignition will last approximately 60 seconds. If there is no flame ignition (rectification) the board will stop sparking for approximately 35 seconds. After this wait time, the board will start a second try for ignition by sparking for approximately 60 seconds. If there is still no positive ignition after the second attempt the board will go into lock out.
- The system will need to be reset as follows (after going into lock out mode):
- a) Wait 5 minutes - turn the system off by pressing the ON/OFF button on the remote.
  - b) After approximately 2 seconds press the ON/OFF button again.
  - c) Unit will repeat step 2.
- 6) If the appliance will not operate, follow the instructions, "To Turn Off Gas to Appliance" and call your service technician or gas supplier. This appliance is equipped with an on-demand pilot that shuts off after seven days.
- 1) **STOP!** Lisez les instructions de sécurité sur la portion supérieure de cette étiquette.
  - 2) S'assurer que le commutateur principal est en position ON et/ou que le bloc-piles mural (le cas échéant) est en position <REMOTE>.
  - 3) Appuyer sur la touche ON/OFF de la télécommande puis relâcher. Un bip sonore retentira depuis le récepteur. Si vous n'utilisez pas la télécommande, l'appareil peut également être allumé en faisant glisser le commutateur du bloc-piles sur la position <ON> (le cas échéant).
  - 4) Après environ 4 secondes, le système d'allumage produira une étincelle pendant 60 secondes pour allumer le brûleur principal.
  - 5) L'appareil s'allumera.
- Remarque : Au premier allumage, le système tente d'allumer les flammes pendant 60 secondes. Si l'essai est infructueux, le système fera une pause de 35 secondes. C'est ce qu'on appelle l'étape de rectification. Ce délai écoulé, le système tente à nouveau d'allumer les flammes en produisant des étincelles pendant 60 secondes. Si les flammes ne s'allument toujours pas, le système se met en mode verrouillage.
- Il faut alors le réinitialiser en suivant les étapes ci-dessous (pour le déverrouiller) :
- a) Attendre 5 minutes et éteindre l'appareil en appuyant sur la touche ON/OFF de la télécommande.
  - b) Attendre 2 secondes et appuyer encore une fois sur la touche ON/OFF.
  - c) L'appareil répétera l'étape 2.
- 6) Si l'appareil ne fonctionne pas, suivez les instructions "Pour couper le gaz au niveau de l'appareil" et appelez un technicien qualifié ou votre fournisseur de gaz.
- Cet appareil est équipé d'une veilleuse sur demande qui s'éteint après sept jours.

**TO TURN OFF GAS TO APPLIANCE / POUR COUPER LE GAZ AU NIVEAU DE L'APPAREIL**

- 1) Press the ON/OFF button on the remote or slide the wall mount switch to the "OFF" position.
  - 2) If service is to be performed—you must disconnect power and shut off gas to the unit.
- 1) Appuyer sur la touche ON/OFF de la télécommande ou faites glisser l'interrupteur mural sur la position "OFF".
  - 2) Lors de l'entretien de l'appareil, vous devez débrancher l'alimentation électrique et couper le gaz alimentant l'appareil.

**DO NOT REMOVE THIS INSTRUCTION PLATE**

**NE PAS ENLEVER CETTE ÉTIQUETTE D'INSTRUCTIONS**

919-649b

## OPTIONAL PROFLAME I REMOTE CONTROL OPERATING INSTRUCTIONS

**IMPORTANT:**The Proflame Transmitter 1 is an integrated part of the Proflame 1 System, which consists of these elements:

- Proflame 1 Transmitter, to be used in conjunction with:
- Integrated Fireplaces Control (Proflame 1 DFG)

The Proflame 1 Transmitter provides for controlling the following hearth appliance functions:

1. Main Burner On/Off
2. Main Burner flame modulation (6 levels)
3. Thermostat and Smart thermostat functions
4. Accent light modulation (6 levels)\*\*
5. Comfort Fan speed modulation (6 levels)\*\*

\*\* This feature is not available on all models.

The Proflame Transmitter uses a streamline design with a simple button layout and informative LCD display (Fig. 1). A Mode Key is provided to index between the features and a Thermostat Key is used to turn on/off or index through Thermostat functions (Fig. 1 & 2). Additionally, a Key Lock feature is provided (Fig. 22).



Figure 1: Proflame Transmitter

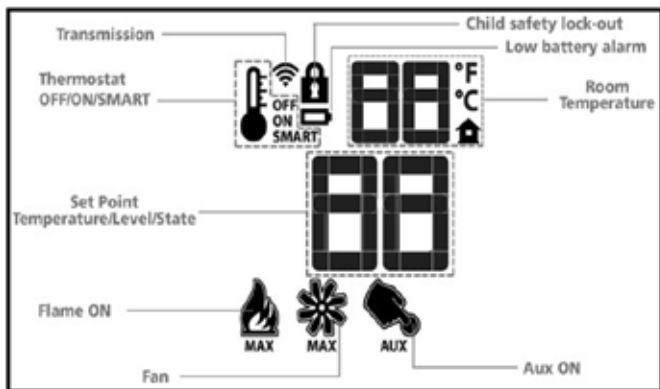

Figure 2: Transmitter LCD Display

TECHNICAL DATA REMOTE CONTROL	
Supply Voltage	4.5V (three 1.5V AAA batteries)
Ambient temperature ratings	0 - 50°C (32 - 122°F)
Radio Frequency	315 MHZ

**WARNING: THE TRANSMITTER AND RECEIVER ARE RADIO FREQUENCY DEVICES. PLACING THE RECEIVER IN OR NEAR METAL MAY SEVERELY REDUCE THE SIGNAL RANGE.**

### ATTENTION!

- Turn "OFF" the main gas supply of the appliance during installation or maintenance of the Receiver device.

- Turn "OFF" main gas supply to the appliance prior to removing or reinserting the batteries.

- In case of remote control malfunction, turn off the IFC device using the "ON/OFF" main switch.

- For installation / maintenance, switch off the IFC device removing main power supply plug.

## OPERATING PROCEDURE

### Initializing the System for the first time

Power the receiver. Press the PRG button located on the top right hand corner of receiver, see the receiver instruction (\*). The Receiver will "beep" three (3) times to indicate that it is ready to synchronize with a Transmitter. Install the 3 AAA type batteries in the Transmitter battery bay, located on the base of the Transmitter. (Fig. 3) With the batteries already installed in the Transmitter, push the On button. The Receiver will "beep" four times to indicate the Transmitter's command is accepted and sets to the particular code of that Transmitter. The system is now initialized.



Figure 3: Battery Compartment

**Note:** Only use regular alkaline batteries. Do not use rechargeable or lithium batteries.

### Temperature indication Display

With the system in the "OFF" position, press the Thermostat Key and the Mode Key at the same time. Look at the LCD screen on the transmitter to verify that a C or F is visible to the right of the room temperature display (Fig. 4 & 5).

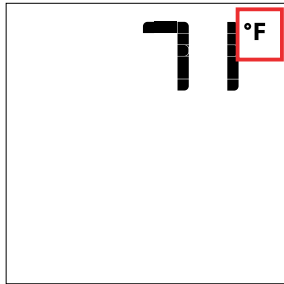

Figure 4: Remote Control display in Fahrenheit.

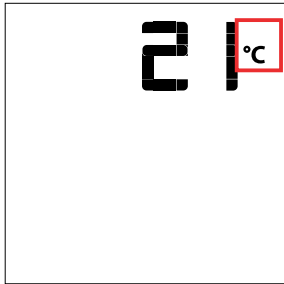

Figure 5: Remote Control display in Celsius.

### Turn on the Appliance

With the system OFF, press the ON/OFF Key on the Transmitter. The Transmitter display will show some other active Icons on the screen. At the same time the Receiver will activate the appliance. A single "beep" from the Receiver will confirm reception of the command.

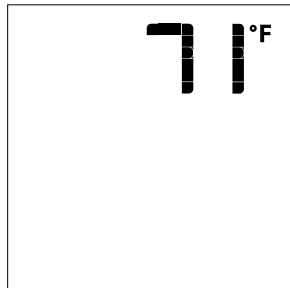

Figure 6: Remote Control display

### Turn off the Appliance

With the system ON, press the ON/OFF Key on the Transmitter. The Transmitter LCD display will only show the room temperature (Fig. 6). At the same time the Receiver will turn off the appliance. A single "beep" from the Receiver confirms reception of the command.

### Remote-Flame Control

The Proflame has six (6) flame levels. With the system on, and the flame level at the maximum in the appliance, pressing the Down Arrow Key once will reduce the flame height by one step until the flame is turned off. The Up Arrow Key will increase the flame height each time it is pressed. If the Up Arrow Key is pressed while the system is on but the flame is off, the flame will come on in the high position (Fig. 7 & 8). A single "beep" will confirm reception of the command.

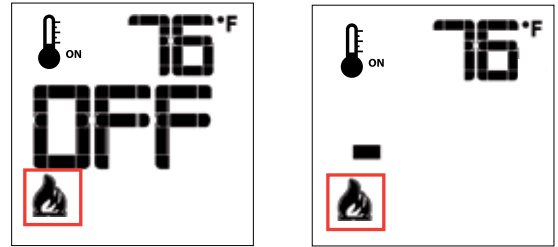

Fig. 7

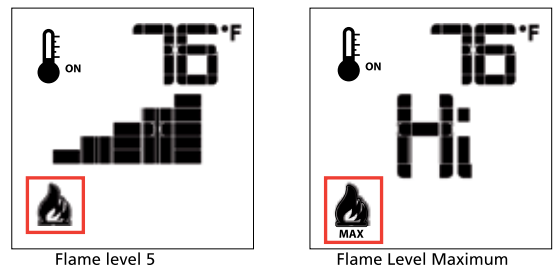

Fig. 8

### Room Thermostat (Transmitter Operation)

The Remote Control can operate as a room thermostat. The thermostat can be set to a desired temperature to control the comfort level in a room. To activate this function, press the Thermostat Key (Fig. 1). The Lcd display on the Transmitter will change to show that the room thermostat is "ON" and the set temperature is now displayed (Fig. 9). To adjust the set temperature, press the Up or Down Arrow Keys until the desired set temperature is displayed on the LCD screen of the Transmitter.

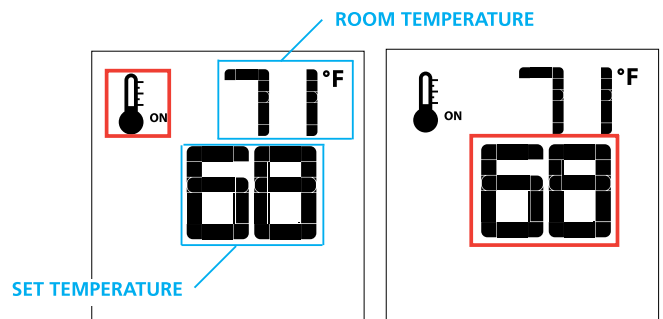

Figure 9

Figure 10

### Smart Thermostat (Transmitter Operation)

The Smart Thermostat function adjusts the flame height in accordance to the difference between the set point temperature and the actual room temperatures. As the room temperature gets closer to the set point the Smart Function will modulate the flame down.

To activate this function, press the Thermostat Key (Fig. 1) until the word "SMART" appears to the right of the temperature bulb graphic (Fig. 11). To adjust the set temperature, press the Up or Down Arrow Keys until the desired set temperature is displayed on the LCD screen of the Transmitter (Fig. 12).

Note. When Smart Thermostat is activated, manual flame height adjustment is disabled.

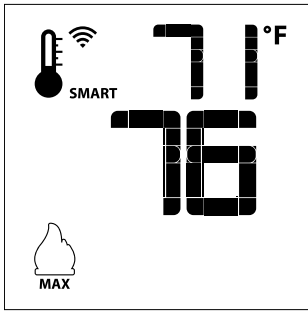

Figure 11: Smart Flame Function

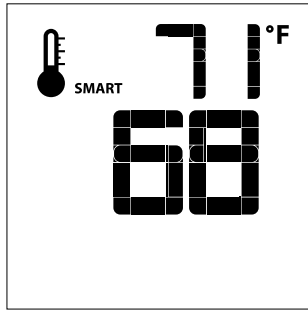

Figure 12

### Fan Speed Control\*\*

If the appliance is equipped with a hot air circulating fan, the speed of the fan can be controlled by the Proflame system. The fan speed can be adjusted through six (6) speeds. To activate this function use the Mode Key (Fig.1) to index to the fan control icon (fig. 13). Use the Up/Down Arrow Keys (Fig.1) to turn on, off or adjust the fan speed (Fig. 14). A single "beep" will confirm reception of the command.

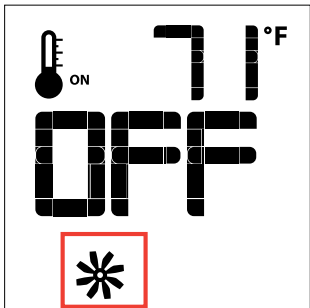

Figure 13

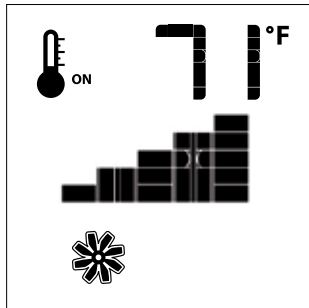

Figure 14

### Remote dimmer control (Light)\*\*

The auxiliary function controls the AUX power outlet by the dimmable light control. To activate this function use the Mode Key (Fig. 1) to index to the AUX icon (Fig. 15 & 16).

The intensity of the output can be adjusted through six (6) levels. Use the Up/Down Arrow Keys (Fig.1) adjust the output level (Fig. 16). A single "beep" will confirm reception of the command.

**Note:** This function is available only with the IFC Control Module.

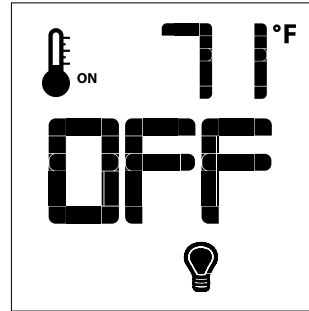

Figure 15

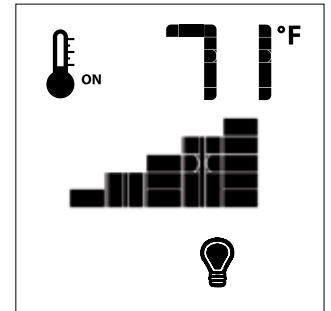

Figure 16

### KEY LOCK

This function will lock the keys to avoid unsupervised operation. To activate this function, press the MODE and UP Keys at the same time (Fig. 21).

To de-activate this function, press the MODE and UP Keys at the same time.

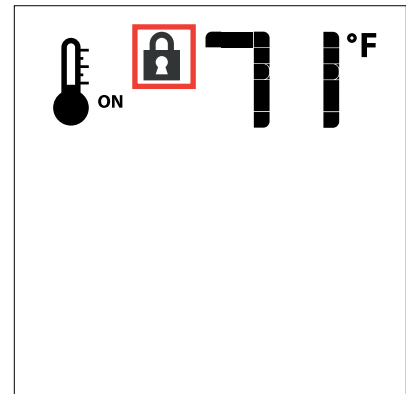
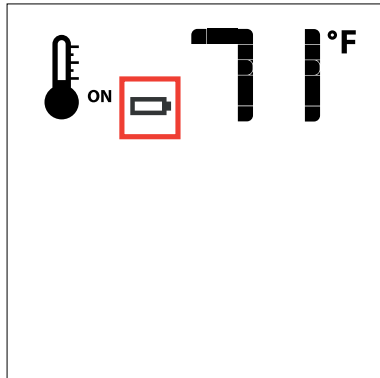

Figure 18

## LOW BATTERY POWER DETECTION

### Transmitter

The life span of the remote control batteries depends on various factors: quality of the batteries used, the number of ignitions of the appliance, the number of changes to the room thermostat set point, etc. When the Transmitter batteries are low, a Battery Icon will appear on the LCD display of the Transmitter (Fig. 22) before all battery power is lost. When the batteries are replaced this Icon will disappear.



### CPI/IPI Switch

This appliance comes equipped with a CPI/IPI switch.

The functions of both the CPI/IPI switch are as follows:

**Continuous pilot (CPI)** - A pilot that, once placed in operation, is intended to remain ignited continuously until it is manually interrupted.

**Intermittent pilot (IPI)** - A pilot that is automatically ignited when an appliance is called on to operate and which remains continuously ignited during each period of main burner operation. The pilot is automatically extinguished when each main burner operating cycle is completed

The mode of the fireplace is easily changed from an intermittent pilot ignition system (IPI) to a continuous pilot ignition system (CPI) by using the silver toggle switch located on the fireplace. (See noted location of CPI/IPI Switch)

The benefits of having CPI are as follows:

- Keeps venting primed for trouble free start-up under colder weather conditions or inversions.
- Keeps the unit glass warm, which decreases the amount of condensation on start-up.
- Provides owners with flexibility to choose a traditional continuous pilot. (7 day/Pilot on Demand)

The primary benefit of having the IPI function is a significant savings on fuel as the pilot will only run when there is a call for heat.

**ENABLE / DISABLE** functions on the Proflame I remote only.

1. Remove one battery from the remote.
2. Press and hold both the **ON/OFF** and the **MODE** button at the same time
3. Reinstall the battery (removed in Step 1) while still holding both buttons (keep holding both buttons and once all batteries are installed then release the **MODE** button only).
4. The screen will show **CFG**.
5. Use the up or down arrow button to program out the function on the remote.

**Note:** You should never program out the fan (If installed) feature on the remote. It is not possible to remove the thermostat mode on this remote control.



*The Surefire switch is located at the bottom right above the DFC board.*



**INSTALLATION GUIDELINES**

1. Locate your appliance. Refer to the "Clearances to Combustibles" and "Minimum Fireplace Clearances" sections.
2. Make gas and electrical connections. Refer to the "Gas Connection" section.  
  
Test the pilot. Refer to the "Pilot Adjustment" section.
3. Install Flue Connector. Refer to the section on installation specifications.
4. Install vent. Refer to the "Venting" section.
5. Test Gas pressure. Refer to the "Gas Pipe Pressure Testing" section.  
  
Check aeration. Refer to the "Gas Insert Aeration System" section.
6. Test for flue spillage. Refer to the "Draffhood Check" section.
7. Install standard and optional features. Refer to the following sections where applicable:
  - a. Brick or Enamel Panels
  - b. Faceplate & Trim
  - c. Circulation Fan
  - d. Remote Control
  - e. Wall Switch
  - f. Wall Thermostat
8. Final check. Refer to the "Final Check" section.

Before leaving this unit with the customer, the installer must ensure that the appliance is firing correctly and operation fully explained to customer.

**This includes:**

1. Clocking the appliance to ensure the correct firing rate (rate noted on label) after burning appliance for 15 minutes.
2. If required, adjusting the primary air to ensure that the flame does not carbon. First allow the unit to burn for 15-20 min. to stabilize.
3. Ensure that the appliance is venting correctly.
4. All original vent systems must be inspected for carbon/soot build up prior to installation of the E18E. The installer should also ensure prior to installation that the existing vent system is adequate for the rated input of this appliance (21,600 BTU NG/20,500 BTU LP).

Signs of white buildup (aldehydes) in the vent system would indicate that the appliance was not drafting properly due to vent height, diameter of vent, excessive offsets, negative pressure, kinks, etc.

Adhere to the local gas code within your jurisdiction for vent sizing.

Any venting system that causes the Regency E18E to not function as it should is not the responsibility of the manufacturer.

**CAUTION: Any alteration to the product that causes sooting or carboning that results in damage is not the responsibility of the manufacturer.**

**GAS CONNECTION**

Only persons licensed to work with gas piping may make the necessary gas connections to this appliance.

The gas connection is a 1/2" NPT accessible on the left side of the unit. The gas line connection may be made of rigid pipe, copper pipe or an approved flex connector. (If you are using rigid pipe, ensure that the valve can be removed for servicing.) Since some municipalities have additional local codes it is always best to consult with your local authorities and the CSA B149.1 installation code.

For USA installations follow local codes and/or the current National Fuel Gas Code, ANSI Z223.1.

When using copper or flex connectors use only approved fittings. Always provide a union so that gas lines can be easily disconnected for burner or fan servicing. Flare nuts for copper lines and flex connectors are usually considered to meet this requirement.

**Important: Always check for gas leaks with a soap and water solution or gas leak detector. Do not use open flame for leak testing.**

Specifications			
For Altitude:	Natural Gas	0-4500 ft.	
	Propane:	0-4500 ft.	
Burner Orifice Sizes:			
Burner	Natural Gas #44	Propane #55	
Max. Input Rating			
	- Natural Gas	21,600 Btu/h	
	- Propane	20,500 Btu/h	
Min. Input Rating			
	- Natural Gas	15,000 Btu/h	
	-Propane	17,000 Btu/h	
Supply Pressure			
	Natural Gas	min.5.0" w.c.	
	Propane	min.12.0" w.c.	
Manifold Pressure (High)			
	Natural Gas	3.5"	w.c.
	Propane	10"	w.c.
Circulation Fan: 120 VAC, 60 Hz			
Variable Speed: 127 CFM, thermally activated			

# installation

## PILOT ADJUSTMENT

Periodically check the pilot flames. Correct flame pattern has two strong blue flames: 1 flowing around the flame sensor and 1 flowing across the burner (it does not have to be touching the burner).

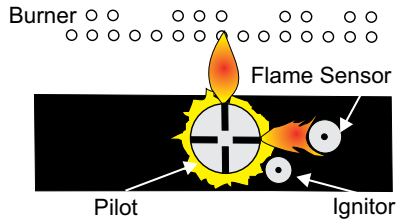

**Note: If you have an incorrect flame pattern, contact your Regency® dealer for further instructions.**

**Incorrect flame pattern will have small, probably yellow flames, not coming into proper contact with the rear burner or flame sensor.**

## GAS PIPE PRESSURE TESTING

The appliance must be isolated from the gas supply piping system by closing its individual manual shut-off valve during any pressure testing of the gas supply piping system at test pressures equal to or less than 1/2 psig. (3.45 kPa). Disconnect piping from valve at pressures over 1/2 psig.

The manifold pressure is controlled by a regulator built into the gas control, and should be checked at the pressure test point.

**Note: To properly check gas pressure, both inlet and manifold pressures should be checked using the valve pressure ports on the valve.**

1. Make sure the switch is in the "OFF" position.
2. Loosen the "IN" and/or "OUT" pressure tap(s), turning counterclockwise with a 1/8" wide flat screwdriver.
3. Attach manometer to "IN" and/or "OUT" pressure tap(s) using a 5/16" ID hose.
4. Light the pilot by turning the switch to "ON" position.
5. The pressure check should be carried out with the unit burning and the setting should be within the limits specified on the safety label.
6. When finished reading manometer, turn off the gas valve, disconnect the hose and tighten the screw (clockwise) with a 1/8" flat screwdriver. ***Note: Screw should be snug, but do not over tighten.***

## HIGH ELEVATION

This unit is approved in Canada for altitude to 4500 ft. (CSA 2.17). For Natural Gas installations above 4500 ft. follow current CAN/CSA B149.1.

## 886 S.I.T. VALVE DESCRIPTION

- 1) Manual high/low adjustment
- 2) Pilot adjustment
- 3) Outlet Pressure Tap
- 4) Inlet Pressure Tap
- 5) Pilot Outlet
- 6) Main Gas Outlet
- 7) Main Gas Inlet

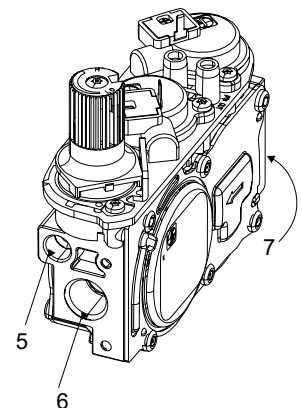
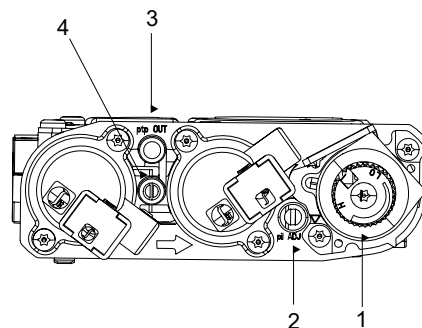

## INSTALLATION CHECKLIST

1. Verify the model of the existing appliance you are installing into is one of the following approved units:

- Montigo EP28-2
- Montigo EP28-4
- Montigo EP28-5
- Montigo Econo Plus 28C
- Montigo EP28-S2
- Montigo 36SR (Non powervent unit)
- Montigo 28F-3
- Montigo 28F-2
- Montigo 28-F
- Firesong 220N
- Firesong 120N

2. Verify all clearances are at least the specified clearances.
3. Inspect existing venting and appliance for signs of wear and durability.
4. Determine the route for the electrical for the circulation fan. The circulation fan is not optional.
5. Determine the route for the gas supply. The valve has a 1/2" Male Flare on the left side of the E18E. Some modification may need to be made to a hard lined gas supply to connect to the E18E.
6. Clean out the existing appliance of all dust and debris.
7. Make the appropriate modifications to the existing appliance specified in the "Existing Appliance Modification" section of the manual. Make sure when done there are no sharp edges exposed to a person during operation of the unit.
8. Unpack the E18E from the box and disassemble.
9. Install the E18E into the existing unit as per instructions.
10. Connect Gas Supply.
11. Connect Circulation Fan Power Cord.
12. Test Fire the E18E and check gas pressures and confirm Circulation Fan begins operation with 10 minutes of firing the unit.
13. Check draft hood for spillage as per instructions.
14. Install Trim Kit as per instructions.

## MATERIALS REQUIRED

Electrical power supply is required for the circulation fan. A 120 Volt AC power cord is hooked up to the fan. Plug the 3 wire cord into a suitable receptacle. Do not cut the ground terminal off under any circumstances. When connected with 120 volts, the appliance must be electrically grounded in accordance with local codes, or in the absence of local codes, with the current Canadian Electrical Code CSA C22.1 (in Canada) or with the current National Electrical Code ANSI/NFPA 70-1987 (in U.S.A.).

**NOTE: This unit is equipped with a heat sensor thermodisc which will prevent the blower from operating until the unit reaches the correct temperature.**

## VENTING

**THE APPLIANCE MUST NOT BE CONNECTED TO A CHIMNEY FLUE SERVING A SEPARATE SOLID FUEL BURNING APPLIANCE.**

This appliance is designed to attach to a 4" diameter type B-Vent or double thickness approved aluminium flex liner.

## VENTING CONFIGURATIONS

The E18E is approved to be attached to any of the approved appliances listed in the Installation Checklist. The existing unit must be connected to B-Vent Pipe having at least 8 feet of vertical venting and can have a maximum of 6 feet horizontal venting with two 90 degree elbows. The venting must terminate vertically with an approved B-Vent Cap.

All horizontal runs must maintain a 1/4" of rise for every foot of horizontal run.

The flue collar of the appliance will fit inside a standard vent and may be fastened directly to the vent using a minimum of 3 sheet metal screws or a B-Vent, single wall vent connector.

B-Vent chimneys require a 1" clearance to combustibles.

The Regency® Insert incorporates its own internal draft hood, so no additional external draft hood is required. Check periodically that the vent is unrestricted and an adequate draft is present when the unit is in operation.

Before installing the vent system ensure that the damper plate is locked into the open position and secure to prevent the damper plate from falling down and crushing the liner.

The appliance is equipped with a vent safety shutoff system and a safety control system designed to protect against improper venting of combustion products. The appliance will not function without being connected to a proper system.

**WARNING: Operation of this heater when not connected to a properly installed and maintained venting system or tampering with the vent shut-off system can result in carbon monoxide (CO) poisoning and possible death.**

This appliance must not be connected to a chimney flue serving a separate solid fuel burning appliance.

For best venting performance, we **recommend** the following venting rules:

1. Use only certified Type B gas vent or approved flex liner.
2. Follow the vent manufacturer's instructions and clearance requirements.
3. Observe any local code restrictions, if any, regarding the installation of gas inserts.
4. Use as few elbows as possible.
5. Keep horizontal lengths as short as possible and maintain at least an upward slope of 1/4 in. (6.4mm) for every 12 in. (305mm) of horizontal run.
6. Terminate the vent with a suitable certified vent cap.

# installation

## MINIMUM FIREPLACE CLEARANCES TO COMBUSTIBLES

Diagram shows the minimum clearances to any combustible material. Installer must check that all installs maintain at least these clearances..

The minimum clearance from the side of the appliance to a combustible side wall is 9" (229mm). The minimum clearance from the bottom edge of the front trim above the window to a combustible mantel is  $17\frac{7}{8}$ " (454 mm). The minimum height from bottom edge of the front trim above the window to the ceiling is  $37\frac{7}{8}$ " (962 mm).

**Note: A non-combustible mantel and framing may be installed at a closer tolerance if the framing is made of metal studs covered with a non-combustible board.**

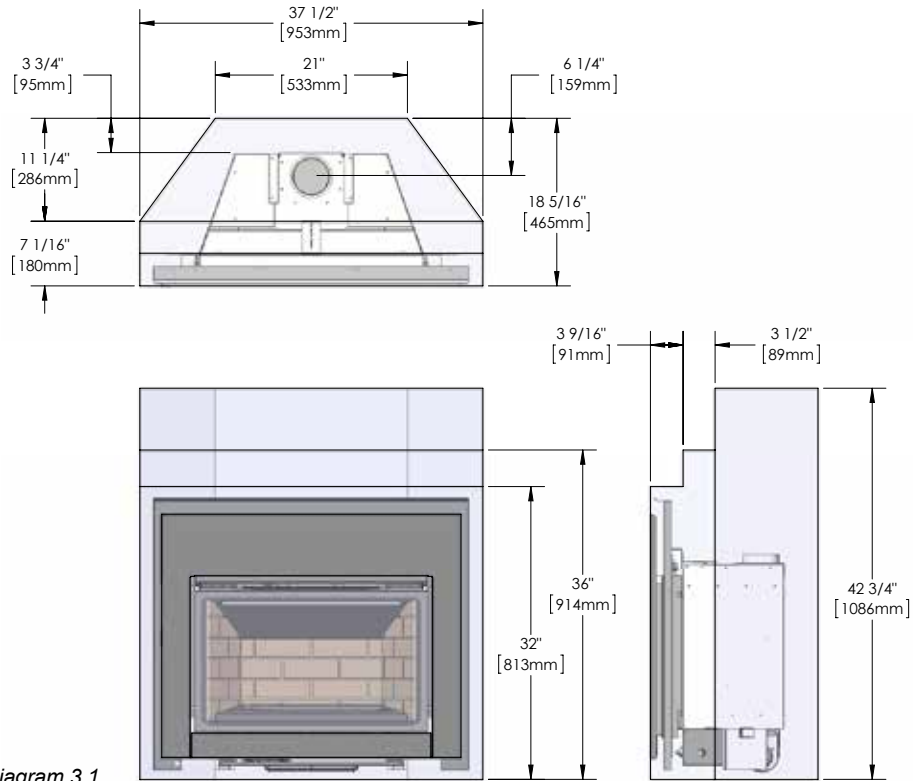

Diagram 3.1

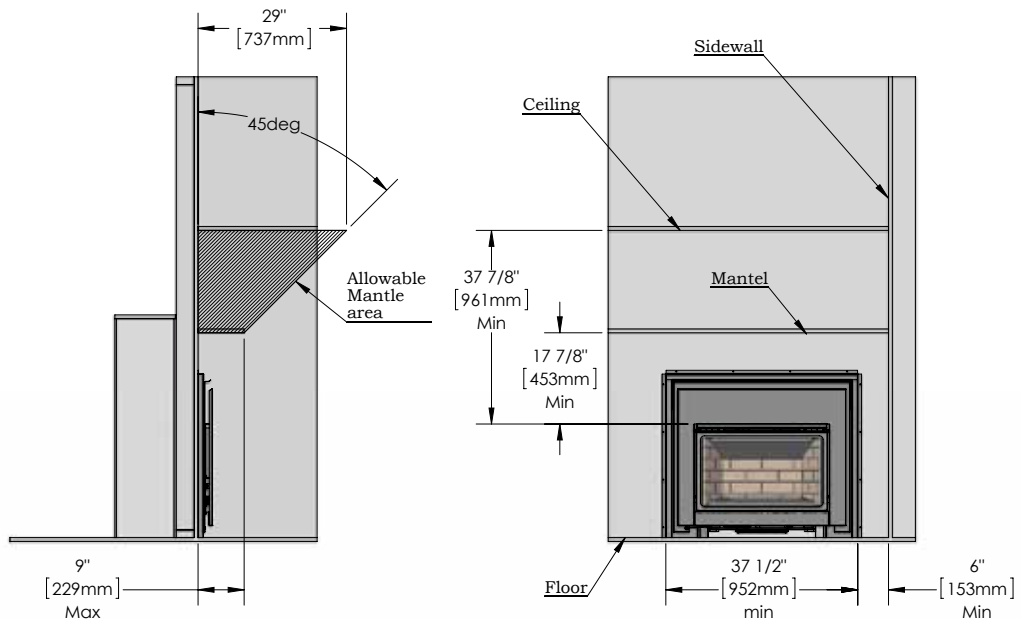
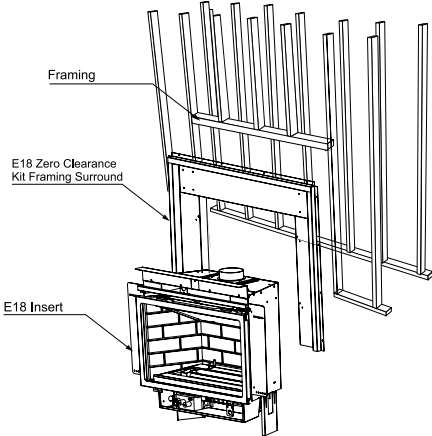

Diagram 3.2

**ZERO CLEARANCE FRAMING DIMENSIONS**

Framing Dimensions	Description	E18E
A	Framing Height	36" (914mm)
B	Framing Width	37 - 7/16" (951mm)
C	Framing Depth	15-1/2" (394mm)

Electrical connection: 110v required  
Fan must be on at all times to operate this unit.



# installation

## ZERO CLEARANCE FRAMING

1. When installing the E18E as a zero clearance, you will use the framing clearances in the following diagrams. Mantel and inside corner clearances can be found in Minimum Clearances to Combustibles.
2. Install the Surround to the framing as per manual.

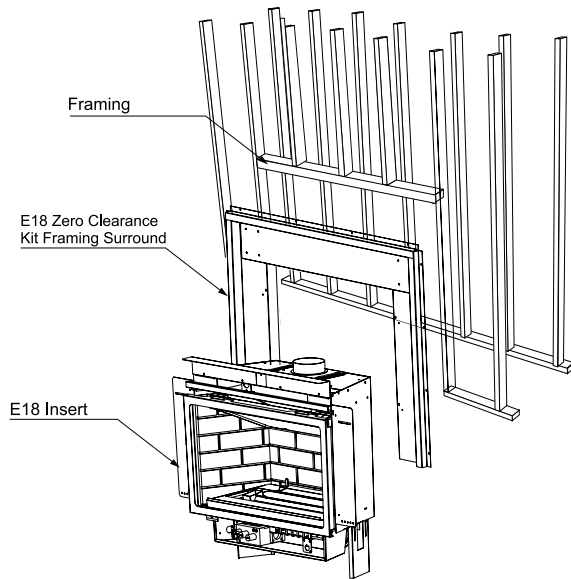
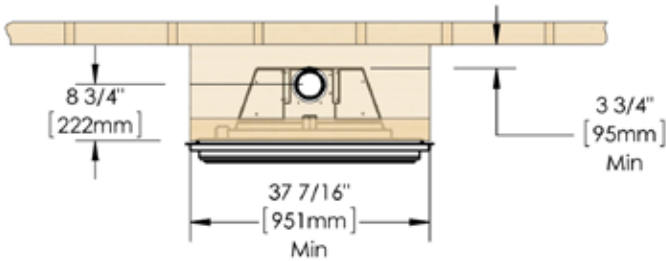

1. Shut down existing unit and allow to cool to room temperature.
2. Turn off gas supply and disconnect electrical.
3. Remove all accessories from existing unit, ie. glass doors, louvers, etc.
4. Remove any tiles, hearth or surround from existing unit (if required).
5. Disconnect gas supply from existing unit.
6. Cut away a perimeter of drywall around the existing unit to expose the framing. See example below.



*Cut drywall*

7. Uninstall existing unit from framing.



*Remove unit from framing*

8. Disconnect venting from existing unit - remove carefully to avoid damage.
9. Remove existing unit from framed opening.



10. Measure framed opening and compare to dimension requirements. Additional adjustments to framed opening may be required.

12. When framing is complete, ensure wiring is installed by an electrician prior to installing the unit.

13. Assemble ZC surround with 8 (904-897) screws provided in locations shown below.

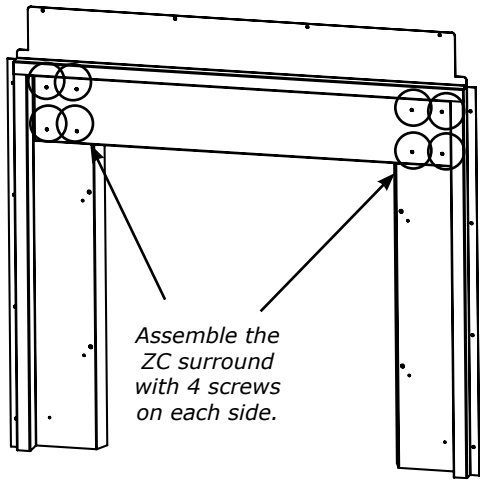

14. Secure surround to the stud on each side with screws.



Use 4 screws on each side to secure surround to studs.

15. ZC surround installed into framed opening.

16. Separate E18E inner and outer fireboxes - see installation into existing unit section in the manual for details.



17. Set E18E outside firebox legs as shown below.

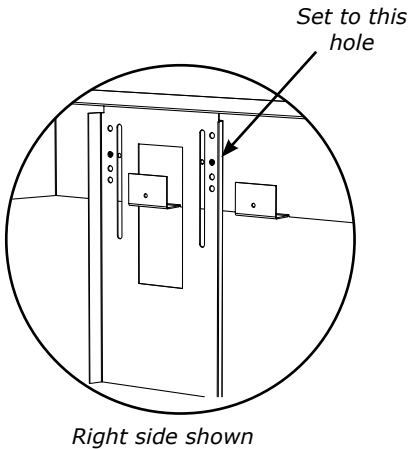

Outside firebox shown in position - refer to measurements (Step 18) before securing to surround.

# installation

18. Follow instructions in the manual for installation into a EP28-2 for exact measurements for installation of the outside firebox to the surround.

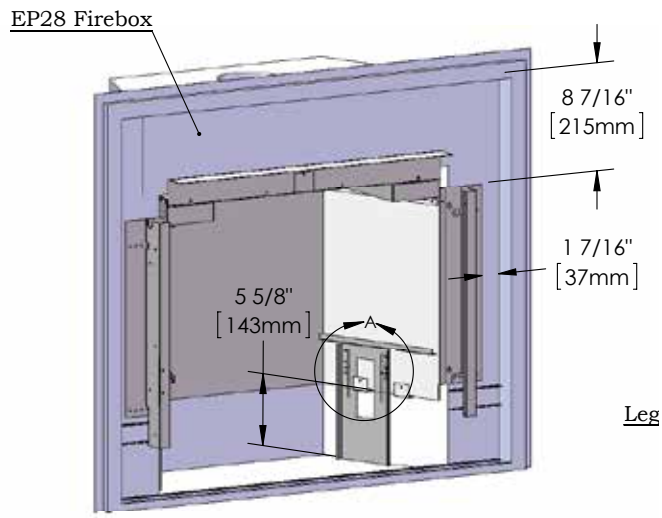

21. Install lower trim piece with 2 (904-897) screws to the bottom of the ZC surround before installing faceplate.

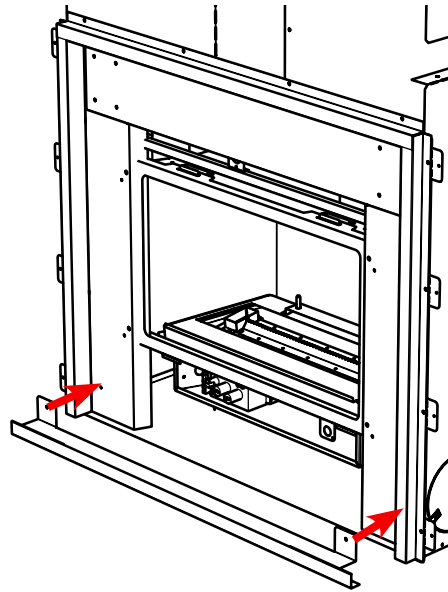

19. The top panel of the ZC surround may be removed to ease the installation of the venting - reinstall top panel after venting is installed.  
\*Extra venting may be required.



20. Follow instructions in the installation into existing unit section in the manual to complete the install of inner firebox.  
Follow Step 21 before installing faceplate.



## ZERO CLEARANCE FACEPLATE INSTALLATION

1. Shut down existing unit and allow to cool to room temperature.
2. Turn off gas supply and disconnect electrical.
3. Remove all accessories from existing unit, ie. glass doors, louvers, etc.
4. Remove any tiles, hearth or surround from existing unit (if required).
5. Disconnect gas supply from existing unit.
6. Cut away a perimeter of drywall around the existing unit to expose the framing. See example below.



*Cut drywall*

7. Uninstall existing unit from framing.



*Remove unit from framing*

8. Disconnect venting from existing unit - remove carefully to avoid damage.
9. Remove existing unit from framed opening.



10. Measure framed opening and compare to dimension requirements. Additional adjustments to framed opening may be required.

### ZERO CLEARANCE FRAMING DIMENSIONS

Framing Dimensions	Description	E18E
A	Framing Height	36" (914mm)
B	Framing Width	37 - 7/16" (951mm)
C	Framing Depth	15-1/2" (394mm)

Electrical connection: 110v required  
Fan must be on at all times to operate this unit.

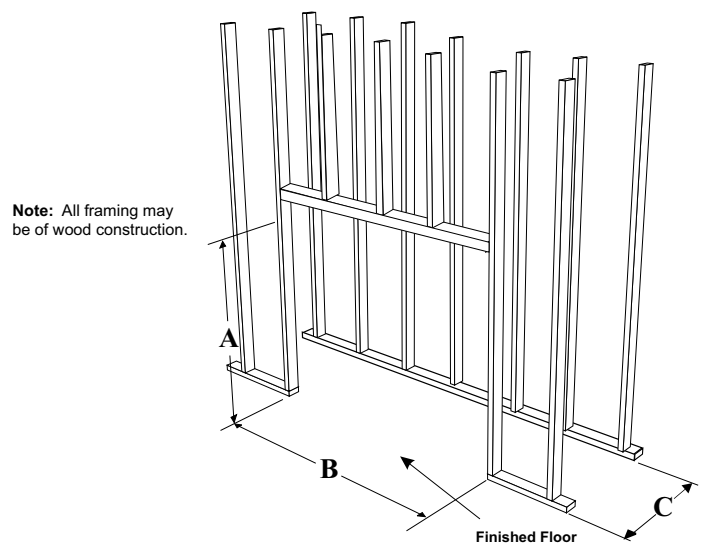

# installation

## ZERO CLEARANCE FRAMING

When installing the E18E as a zero clearance, you will use the framing clearances in the following diagrams. Mantel and inside corner clearances can be found in Minimum Clearances to Combustibles.

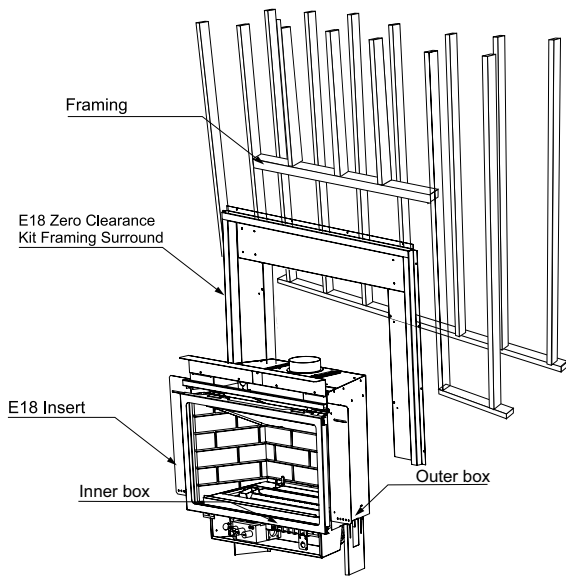
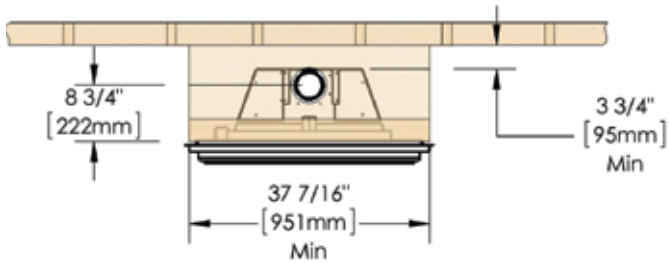

## ZERO CLEARANCE INSTALLATION

1. When framing is complete, ensure wiring is installed by an electrician prior to installing the unit.
2. Assemble ZC surround with 8 (904-897) screws provided in locations shown below.

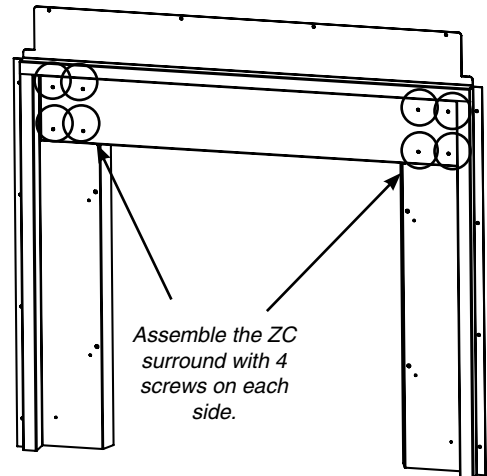

3. Secure surround to the stud on each side with wood screws (not supplied).



Use 4 screws on each side to secure surround to studs.

4. ZC surround installed into framed opening.



5. Separate E18E inner and outer fireboxes - see installation into existing unit section in the manual for details.

6. Set E18E outside firebox legs as shown below.

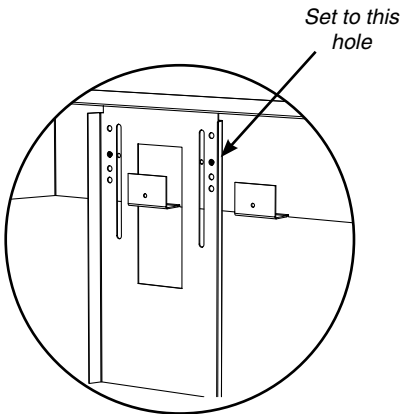

Right side shown



Outside firebox shown in position - refer to measurements (Step 7) before securing to surround.

7. Follow instructions in the manual for installation into a EP28-2 for exact measurements for installation of the outside firebox to the surround.

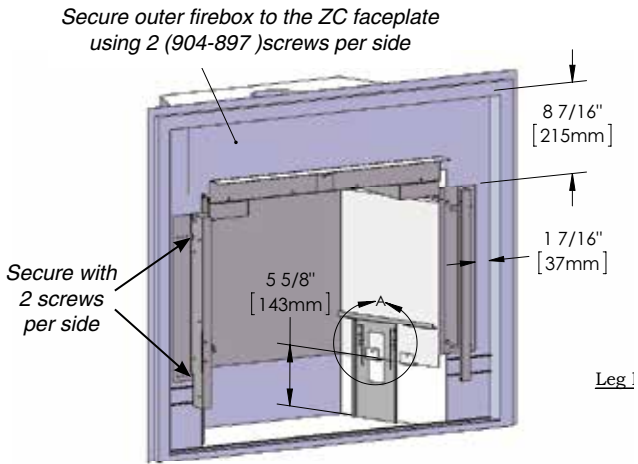

8. The top panel of the ZC surround may be removed to ease the installation of the venting - reinstall top panel after venting is installed. \*Extra venting may be required--which is not included.



9. Follow instructions in the installation into existing unit section in the manual to complete the install of inner firebox. Follow Step 10 before installing faceplate.

10. Install lower trim piece with 2 (904-897) screws to the bottom of the ZC surround before installing faceplate.

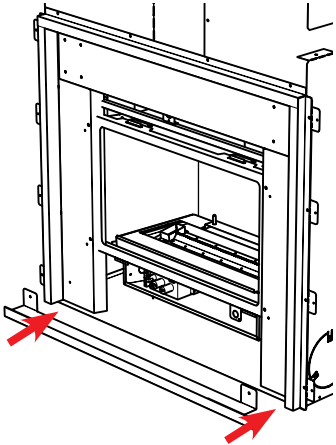

# installation

## FACEPLATE INSTALLATION

**ONLY TRIM KIT SUPPLIED BY THE MANUFACTURER SHALL BE USED IN THE INSTALLATION OF THIS APPLIANCE.**

1. Remove glass door and screen from unit by removing 2 screws. See below.



Retainer Screws

Diagram 13.1

2. Remove control box from rear surround by removing 2 screws. Disassemble control box, insert both fan control switch, fan control knob and on/off switch. Attach yellow and red wires to on/off switch as shown below and connect 2 female wires from fan speed control to 2 male wire connectors from wiring harness at appliance. Reassemble control box.

NOTE: The fan speed control is secured using a lock nut. The on/off switch is simply snapped into position and control knob slides over the fan control switch. Note the orientation of the on/off switch wires. See diagrams below.

2 female wires

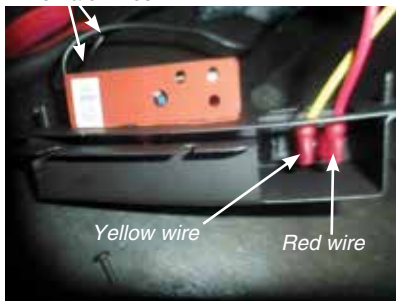

Diagram 13.2



3. Run wire harness from unit through notch in mounting bracket and then to control box as shown below.

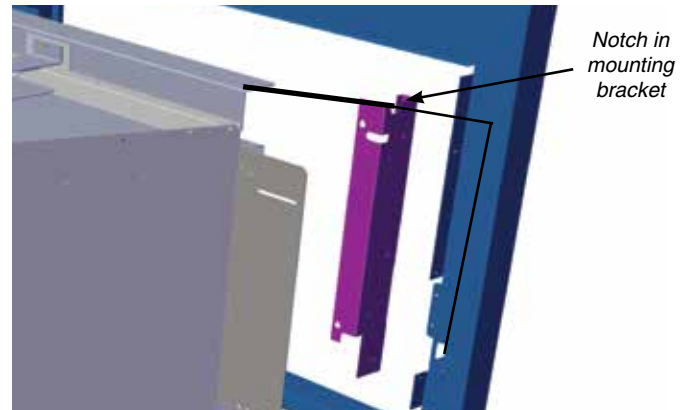

Diagram 13.3

4. Attach control box to left mounting bracket with 2 screws.

NOTE: The screws are only a guide and do not fasten the bracket. The backing plate keeps the control box in place for ease of service.

5. Tuck wire harness on left top groove and secure with wire clips.
6. Feed power cord through left grommet. (If power outlet is on the right side of the unit, feed power cord through right grommet and use wire grommets to secure power cord inside the unit). See diagram 13.4.
7. Secure backing plate with mounting brackets to outer box by screwing 4 self tapping screws on flanges.

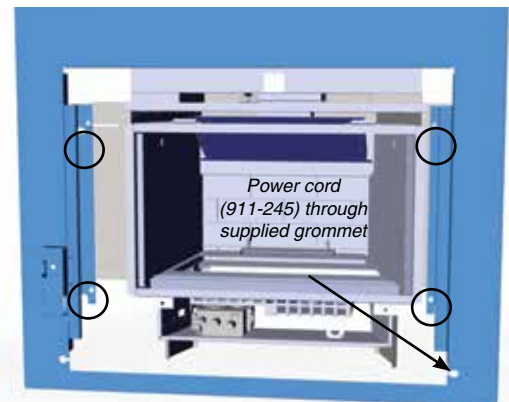

Diagram 13.4

- 8. Attach front faceplate with 4 screws (2 on each mounting bracket). (Touch up screws with black paint, after install.)

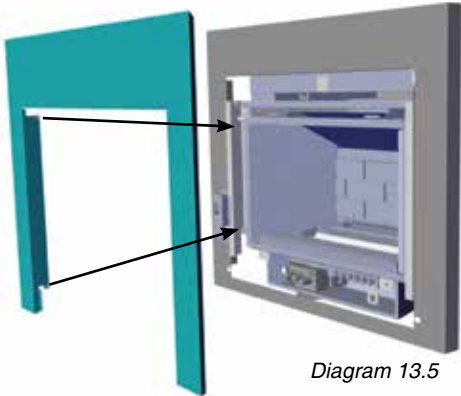

Diagram 13.5

- 9. Reinstall glass door and screen removed from step 1.

- 10. Locate the 'DC supply' wire on the wiring harness, the wire will be clearly marked. Attach the AC adaptor to the DC supply wire as shown. Do not plug into a 120V circuit until the install is complete.



AC adaptor DC supply wire from wiring harness

Diagram 13.6

- 11. Install control cover, adjust horizontal alignment by sliding control cover to ensure even spacing on both sides. Ensure control cover is seated down all the way.

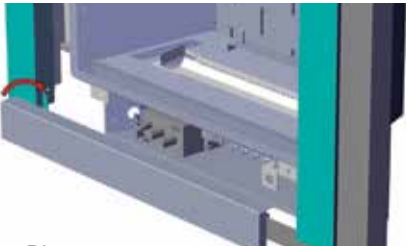

Diagram 13.7

**MONTIGO 28 F3 ONLY**

- 12. To install filler piece, slide under faceplate and secure to backside of faceplate with magnets.



- 13. Completed install of filler piece.



**DRAFT RELIEF OPENINGS MUST NOT BE COVERED OR BLOCKED.**

# installation

## OPTIONAL WALL THERMOSTAT

A wall thermostat may be installed if desired, connect the wires as per the wiring diagram. Use table below to determine the maximum wire length.

**Note: Preferable if the thermostat is installed on an interior wall.**

Regency® offers an optional programmable thermostat but any 250-750 millivolt rated non-anticipator type thermostat that is CSA, ULC or UL approved may be used.

**CAUTION**  
**Do not wire millivolt wall thermostat wires to 120V wire.**

### Thermostat Wire Table

Recommended Maximum Lead Length (Two-Wire) When Using Wall Thermostat (CP-2 System)	
Wire Size	Max. Length
14 GA.	50 Ft.
16 GA.	32 Ft.
18 GA.	20 Ft.
20 GA.	12 Ft.
22 GA.	9 Ft.

## OPTIONAL REMOTE CONTROL

Use the Regency® Remote Control Kit approved for this unit. Use of other systems may void your warranty.

The remote control kit comes with a hand held transmitter and receiver.

### See Wiring Diagram for Remote installation

Receiver cannot be wall mounted, receiver to be installed in the fireplace.

1. Install 3 AAA alkaline batteries in transmitter and 4 AA alkaline batteries in the receiver. Switch the remote receiver to "remote" mode. The remote control is now ready for operation.
2. Receiver to be mounted in the fireplace - can not be wall mounted.

**CAUTION**  
**Do not wire millivolt remote control wires to 120V wire.**

## OPTIONAL WALL SWITCH

1. Run up to 10' of wire through the right or left side gas inlet opening. Be careful not to damage wire.

**Note: We recommend a maximum of 10' of wire but if you wish to go with a longer run, use the Thermostat Wire Table.**

### See Wiring Diagram for Wall Switch installation

**CAUTION**  
**Do not wire millivolt wall switch wire to 120V wire.**

## AC POWER ADAPTOR INSTALLATION (FOR SUREFIRE SYSTEMS)

An AC power adaptor **MUST** be installed as a constant power source for the SureFire system.

IMPORTANT: Do not use the 4-AA batteries in the SureFire receiver.

### INSTALL AC ADAPTOR WITH SUREFIRE WALL SWITCH/WALL THERMOSTAT ONLY - (WITHOUT REMOTE)

1. Locate "DC Supply" tag on wire harness (located in the unit).



2. Connect the male end from AC adaptor to the female end tagged "DC Supply" on wiring harness in unit.



3. Plug AC adaptor into 120V power cord located inside the gas fireplace firebox).

4. Neatly tuck any loose AC Power Adaptor wires underneath / inside the appliance.

Note: Ensure that wires do not touch the underside of the firebox (keep wires away from the heat as much as possible).

### INSTALL AC ADAPTOR WITH SUREFIRE PROFLAME REMOTE

1. Connect the male end of the AC adaptor (from unit) to the female end of the wire adaptor (supplied with optional remote) together as shown.



Wire adaptor

AC adaptor

2. Locate FCM - COM connector labeled on the Remote wire harness.



FCM - COM

3. Attach female end of DC supply wire (red/black) from valve wiring harness located on unit to the male FCM-COM supply wire (red/black) from remote control wiring harness - be careful not to damage ends. This only fits one way. Do Not Force in wrong way.

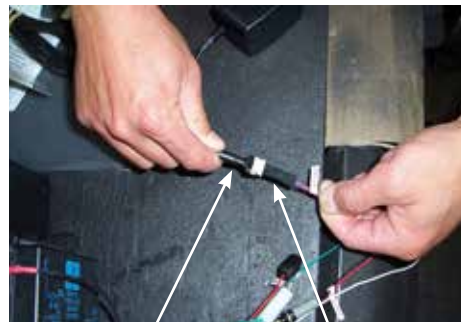

AC adaptor wire adaptor

FCM - COM

4. Plug AC adaptor into 120V wall outlet (or into 120V power cord located inside the gas fireplace firebox).

5. Neatly tuck any loose AC Power Adaptor wires underneath / inside the appliance.

**Note:** This should only be plugged in when unit is fully installed and ready for use.

**Note:** Ensure that wires do not touch the underside of the firebox (keep wires away from the heat as much as possible).

# installation

## OPTIONAL GTM REMOTE INSTALLATION

1. Shut off the gas supply and disconnect all power to the unit.
2. Remove the control cover.
3. Identify short (3" long) brown wire that is attached to the white wire coming from the DFC. Remove the 3" brown wire and discard.



Discard  
3" brown  
wire

4. Connect the Green wire from the GTM wire harness to the brown, connect the white wire from the same harness to white.

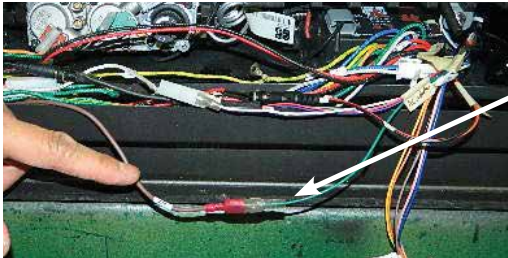

Brown to  
Green

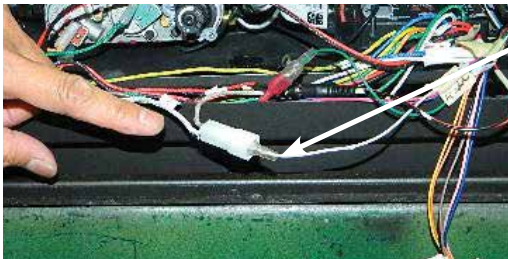

White to  
White

5. See AC adaptor install instructions in this manual.

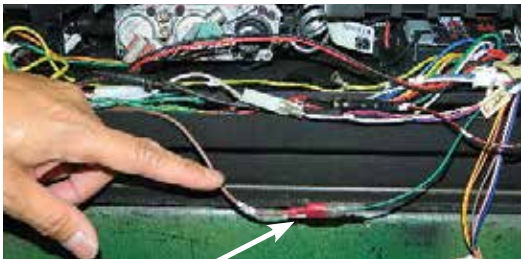

Brown to  
Green

6. Remove the hi/lo knob if installed by removing 2 screws as shown below.

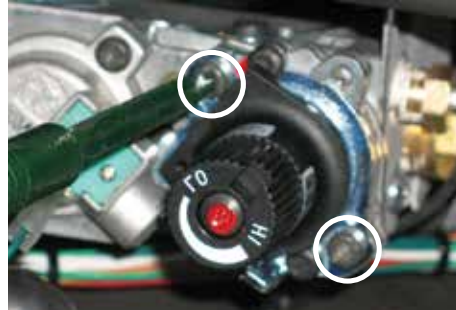

7. Install the stepper motor in the same location the hi/lo knob was removed from - with 2 screws as shown below.



8. Plug wiring harness into back of receiver as shown below.



9. Plug the stepper motor into the 'motor wire as shown below.

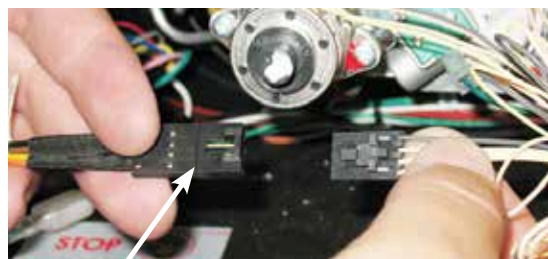

Motor Wire



10. To unattach these wires - un-clip from the wires on the stepper motor side as shown below.

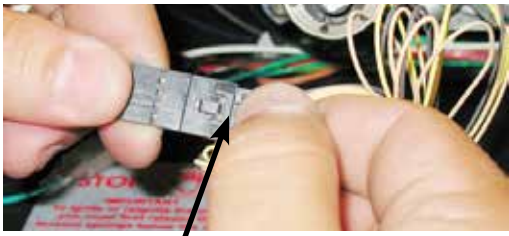

*Press down this tab*

11. Bundle all wires together and clip with supplied wire clip - as shown below.



12. Attach the receiver to the floor of the unit with a velcro pad - also peel off paper on back side of wire clip and place wires conveniently in appliance.

13. Switch on left side of faceplate must be in <ON> position.



14. Match the remote control to the receiver - see remote control instructions.

15. Reverse steps 2 and 1.

# installation

## CONVERSION KIT 617-977 - NATURAL GAS TO PROPANE USING SIT 886 GAS VALVE

**THIS CONVERSION MUST BE DONE BY A QUALIFIED GAS FITTER  
IF IN DOUBT DO NOT DO THIS CONVERSION !!**

**Each Kit contains one LPG  
Conversion Kit  
LPG Conversion Kit Contains:**

Qty.	Part #	Description
1	904-977	Burner Orifice #55
1	918-590	Decal "Converted to LPG"
1	908-528	Red "LPG" label
1	904-529	5/32" Allen Key
1	911-009	Hi/Lo regulator
1	910-037	LPG Injector (Pilot Orifice)
1	920-028	Instruction Sheet

1. Turn the unit off and allow it to cool to room temperature.
2. Unplug or disconnect power source to stove.
3. Remove glass front (see manual).
4. Remove Log or Glass Burner (see manual).
5. Unscrew NG burner orifice and replace with LP orifice.
6. Remove burner orifice with a 1/2" wrench. Use another wrench to hold on to the elbow behind the orifice. Discard orifice.



Burner Orifice



Burner Orifice

7. Remove pilot retainer clip with pliers and pull off the pilot cap to expose the pilot orifice.



Pilot retainer clip



8. Pull off the pilot cap to expose the pilot orifice.



9. Unscrew the pilot orifice with the allen key; then replace with the LPG pilot orifice and the pilot cap, provided in the kit.



10. Reinstall new burner orifice LPG stamped #55 and tighten

11. Remove Hi/Lo pressure regulator by removing 2 screws as shown below. Reverse steps to install LP pressure regulator.



12. Attach the label "This unit has been converted to LPG" near or on top of the serial # decal.

13. Replace yellow "NG" label with red "LPG" label.

14. Reverse steps 3 - 1.

15. Check for gas leaks.

16. Check inlet and outlet pressures.

17. Check operation of flame control.

18. Adjust the burner aeration setting to Fully Open and adjust as required for the best flame picture.

19. See manual for Gas Pressure Testing instructions

**Installer Notice:**

**These instructions must be left with the appliance.**

## GLASS BURNER INSTALLATION / REMOVAL

1. Angle the Glass Burner up on left side and slide the mixing tube over the orifice.



Diagram 14.1

2. Make sure to feed the Air Shutter Bar through the lower hole in the valve tray, just above the ignitor as you place the Glass Burner in.



Diagram 14.2

3. Screw down the Glass Burner with two screws.



Diagram 14.3

4. Hang the Front Burner Cover on the front edge.



Diagram 14.4

5. To remove - reverse Steps 4-1.

# installation

## ENAMEL PANEL INSTALLATION

Black Enamel Panels
<ul style="list-style-type: none"><li>• Black Enamel panels must be inspected for scratches and dimples prior to installation. All claims to be recorded at this time. Claims for damage after installation will not receive consideration.</li></ul>
<ul style="list-style-type: none"><li>• Black Enamel panels will discolor a little during normal operation. This is normal and should not be considered a defect.</li></ul>
<p>* All hand and finger marks <b>MUST</b> be cleaned off with a soft cloth. Use an ammonia based cleaner (ie. glass cleaner) to remove any fingerprints before applying heat to the unit. <b>Failure to do this will result in burn stains on panels which you will be unable to remove.</b> Not protected by product warranty.</p>

1. Centre back panel on the back wall of the firebox.

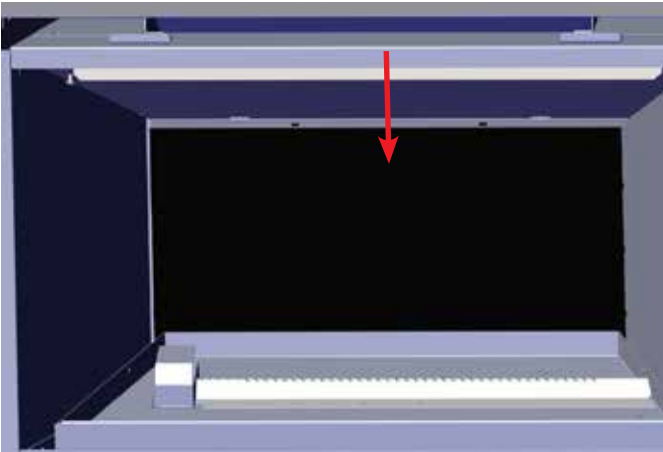

3. Secure panel in position with the two clips provided.

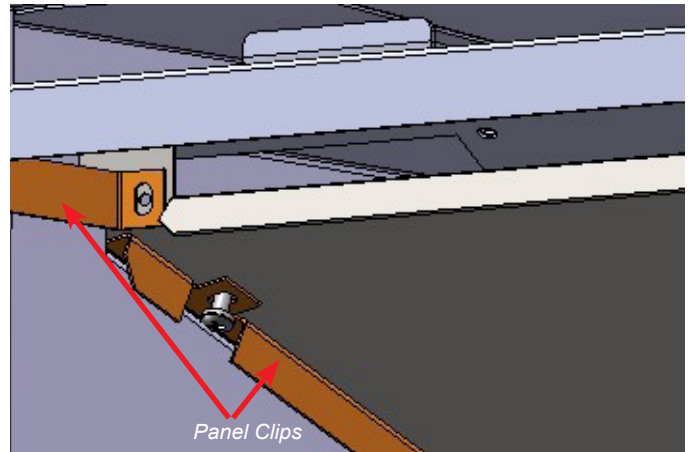

2. Slide in side panel into place in lower track.

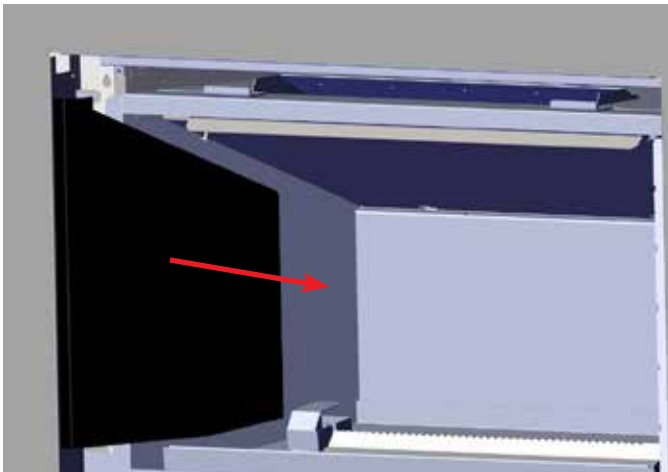

4. Repeat steps 2 & 3 on other side.

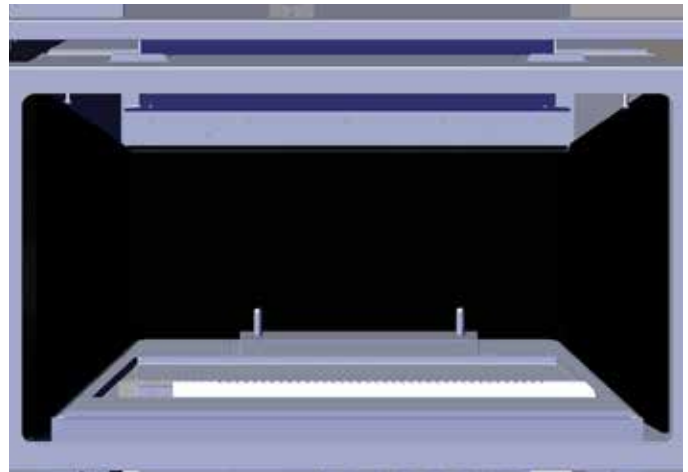

*Final Install*

## GLASS CRYSTALS AND OPTIONAL CERAMIC SPA OR VOLCANIC STONES INSTALLATION ON BURNER AND FIREBOX FLOOR

Evenly spread the Glass Crystals or optional Ceramic Spa Stones over the burner. Ensure the crystals (or stones) do not overlap too much as this will effect the flame pattern.

### IMPORTANT NOTE:

Only the supplied approved Glass Crystals and Ceramic Spa Stones are to be used with these fireplaces. Use of any other type of glass crystals or stones can alter the unit's performance, any damage caused by the use of any unapproved glass or stones will not be covered under warranty.

When using Ceramic Spa Stones **DO NOT** cover burner ports or pilot light that lead to pilot flame. Ensure the crystals or stones do not overlap excessively as this will effect the flame pattern.

BURNER PACKAGES			
Unit	*Glass Crystals	**Ceramic Spa Stones	Volcanic Stones
E18E	5 lbs	70 spa stones	1 box

**NOTE:** \* Glass Crystals are available in 1lb and 5lb bags.  
 \*\* Ceramic Spa stone package contains 70 stones



Diagram 15.1



Diagram 15.2

1. Start installing Crystals on back of Burner and Firebox Floor



Diagram 15.3

2. Distribute Crystals evenly towards front of Burner and Firebox Floor



Diagram 15.4

3. Spread Crystals evenly over the burner and firebox base



Diagram 15.5

4. Ensure Crystals **DO NOT** block the front of the pilot hood and flame to light the burner



Diagram 15.6

Glass Crystals shown on Burner and Firebox Floor

**NOTE:** Correct final glass installation of Crystals shown in step 3 and 4. The Burner and Firebox Floor should not be visible when the flame is out.

## OPTIONAL SPA OR VOLCANIC STONES INSTALLATION (AROUND BURNER)



Diagram 15.7



Diagram 15.8

**NOTE:** Spa or Volcanic Stones are **NOT** to be placed anywhere on the burner tube or Pilot assembly area.

# installation

## BRICK PANEL INSTALLATION

1. Position back brick panel on the back wall of the firebox.

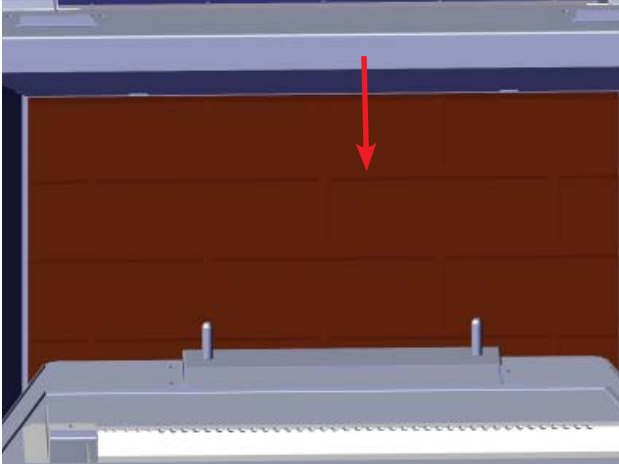

5. Repeat steps 2-4 on other side.

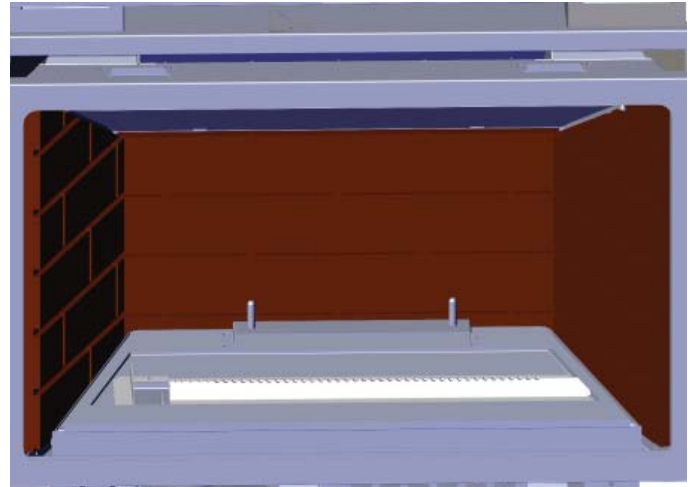

*Final Install*

2. Slide in side panel.

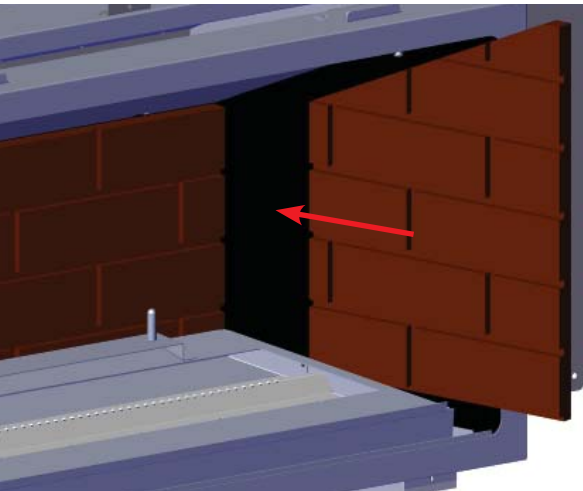

3. Position panel so that grout line in the panel lines up with screw in the baffle.

4. If required, lower screw to secure panel in position.

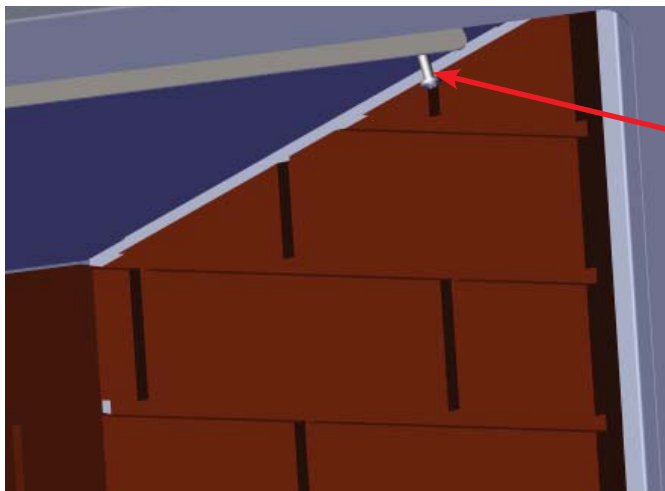

*Line up screw and grout line.*

## LOG TRAY INSTALLATION

1. Remove the Log Burner Tray from the box. Hang the front burner cover on the front edge of the burner tray. Place the Log Burner Tray on the Glass Burner Tray.



2. Screw the Log Burner Tray to the Glass Burner Tray.



3. Install the Log Burner the same way as the Glass Burner (see installation manual for instructions).

4. Fill the Log Burner with 2lbs of black glass crystals.



## LOG SET INSTALLATION

Installation of Panels must be completed before installing the log set.  
 \* Log instructions shown with Black Enamel Panels

Read the instructions below carefully and refer to the images. If the logs are broken do not use the unit until they are replaced. Broken logs can interfere with pilot operation.

Improper positioning of the logs may create carbon build-up and can alter the unit's performance which is not covered under warranty.

Log Kit #619-935 contains the following pieces:

A	Rear Log
B	Front Left Log
C	Front Right Log
D	Left Side Log
E	Right Side Log
946-675	2lb Fireglass
946-669	Platinum Embers
946-708	Embaglow Embers
	1C Ember Lava
616-515	Log Tray Assembly
	Screws x 2

1. Place Log A over the two posts at the back of the log burner.

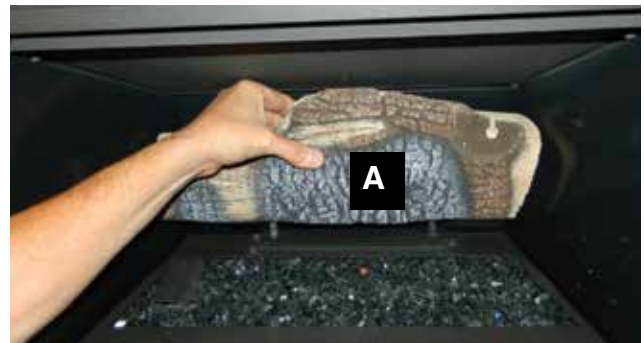

2. Place Log B at the front left of the Log Tray.

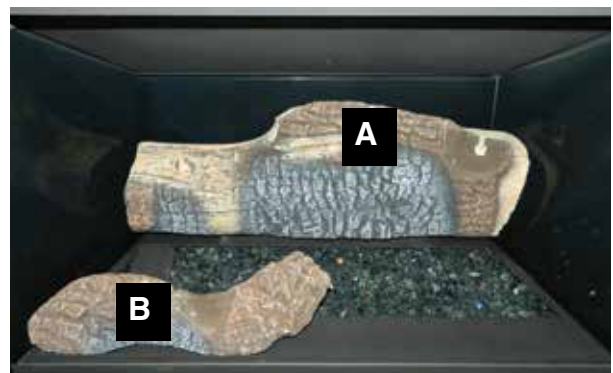

# installation

3. Place Log C at the front right of the log tray.

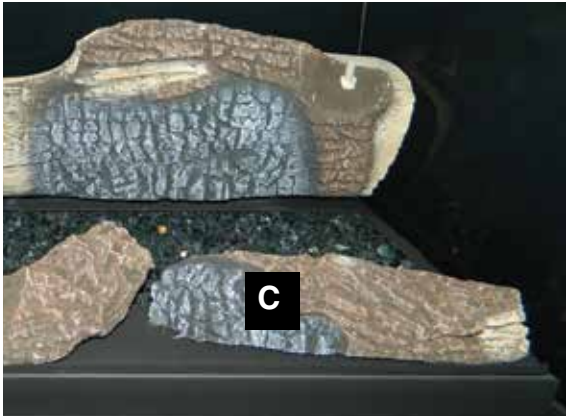

4. Place ember lava, platinum embers, and embaglow on the burner, being careful not to cover the pilot or the gas ports.

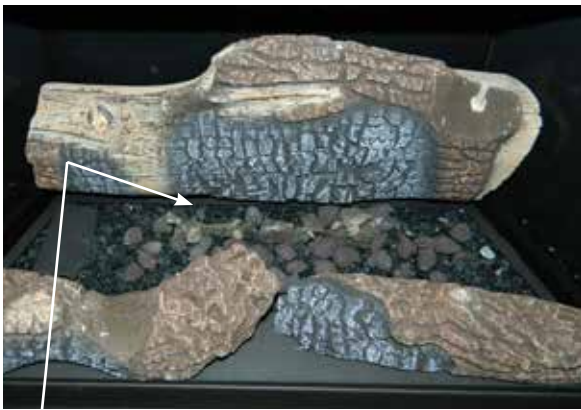

*Ember Lava, Embaglow, Platinum Embers*

5. Place Log D on the left pin of Log A and the groove in Log B.

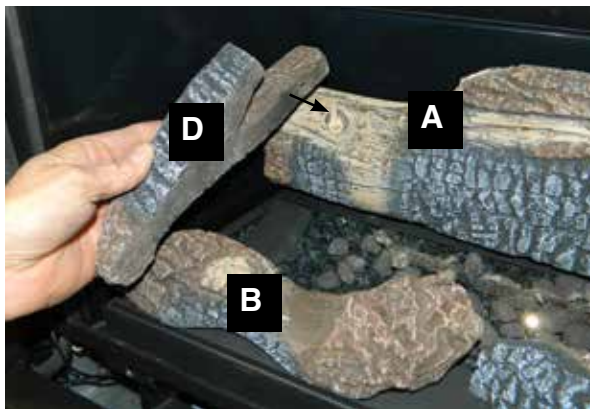

6. Place Log E on the right pin on Log A and on top of Log C.

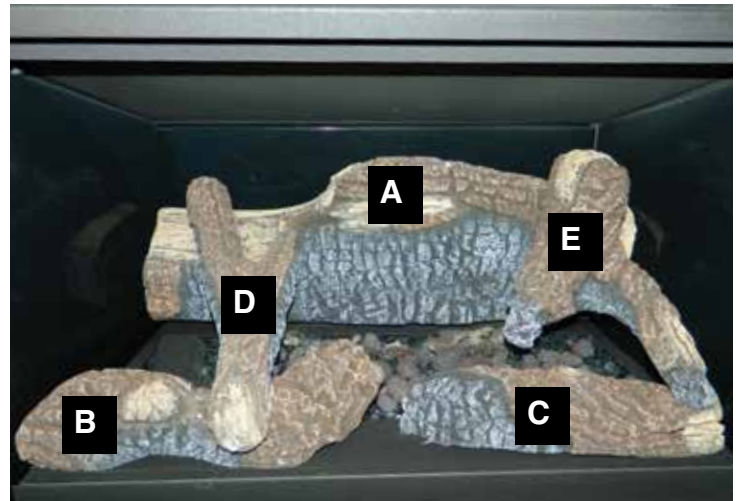
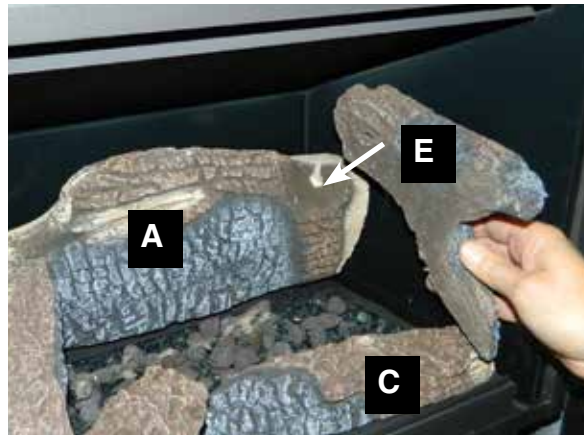

*Final Install*



## OPTIONAL LOG SET INSTALLATION

Read the instructions below carefully and refer to the images. If the logs are broken do not use the unit until they are replaced. Broken logs can interfere with pilot operation.

Improper positioning of the logs may create carbon build-up and can alter the unit's performance which is not covered under warranty.

\*Satin dark brown paint is included if touch ups are required.

1	Rear Log
2	Left Log
3	Right Log
4	Front Center Log Piece
5	Front Left Log Piece
	Log Brackets x 2

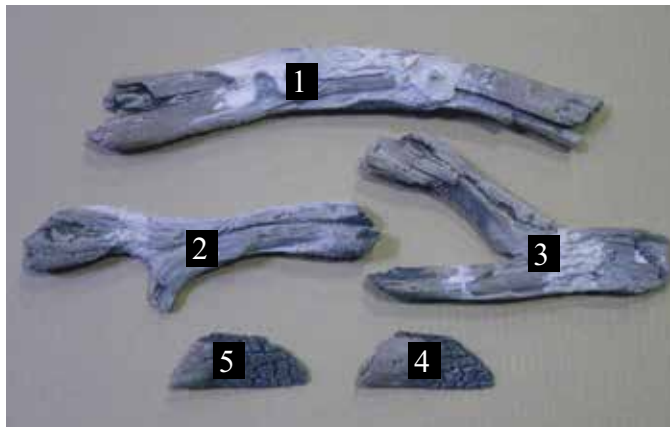

1. Shut off gas and electrical supply, allow unit to cool to room temperature.
2. Remove flush glass door (see unit manual).
3. Carefully remove the logs from the packaging and unwrap them. The logs are fragile, handle with care -never force into position.
4. Ensure glass crystals are installed on the burner.  
E18 = 5lbs
5. Install log brackets by clipping brackets to back of burner tray - measure 4" from outside edge of the burner tray to outside edge of bracket.



Brackets installed 4" from outside edge of burner tray

6. Install Rear Log (1), center log and rest on both left and right log brackets with pins facing up.



Rear log in position

7. Install Log 2 by matching pin locator on Log 2 with left pin on Log 1 as shown below.



Log 2 pin locator match with Log 1 pin

8. Log 2 in position, Log 2 should touch lip of burner approximately 4-1/2" from the left outside edge of burner tray.



Log 2 in position

# installation

9. Place Log piece (4) on the glass crystals in the location shown below.

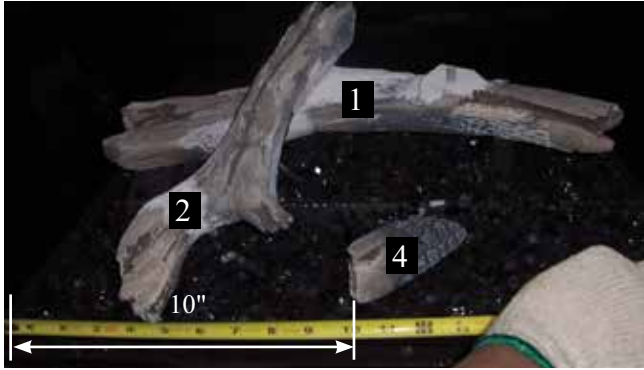

*Right Log piece(4) positioned on glass*

10. Install Log 3 by matching pin locator on Log 3 with right pin on Log 1 as shown below.



*Installing Log 3*

11. Installed Log 3 should touch burner position in the location shown below.  
\* Measurement taken from left edge of burner tray - approximately 18".



*Installed position of Log 3*

12. Position Log 5, rest on pilot hood as shown below.



*Log 5 in position*

13. Place lava embers/rocks on glass - ensure rocks do not block pilot. Do not place lava rocks/embers too close to logs as this may cause carboning.

14. Adjust aeration, see unit manual for setting.

15. Reverse Steps 2 and 1.



*E18 final install*

## GLASS DOOR / SCREEN INSTALLATION/ REMOVAL

1. Remove control cover to access door retainer screws.
2. Remove 2 door retainer screws. (Diagram 16.1)
3. Pull door out, then lift up and out to remove. (Diagram 16.2)
4. Reverse Steps 3-1 to reinstall.

**WARNING:**  
Do not operate appliance with the glass front removed, cracked or broken. Replacement of the glass should be done by a licensed or qualified service person.



Retainer Screws

Diagram 16.1



Diagram 16.2

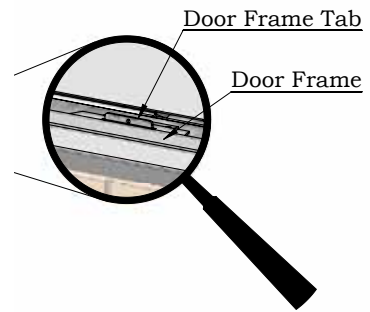

## SAFETY SCREEN REPLACEMENT PART # 616-929

1. Remove Door as per E18E Installation section of the manual.
2. Remove the 4 screws to remove Safety Screen from Door.
3. Reverse order to reattach.
4. Install control cover supplied with screen.

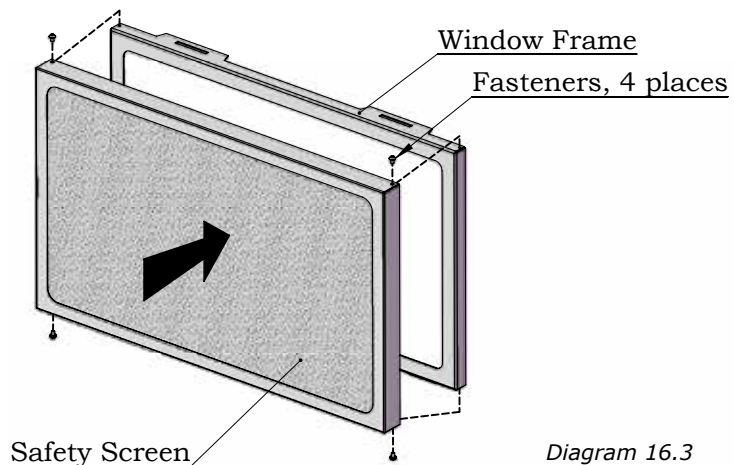

Diagram 16.3

# installation

## DRAFTHOOD CHECK

A "spillage" test must be made before the installed unit is left with the customer. Follow the procedure below:

1. Start all exhaust fans in the home and then close all external doors and windows in the house. Remove the Front Trim from the E18E to gain better access to the Drafthood Opening. Make sure the Glass Door is on properly.
2. Light the unit and set controls to maximum.
3. After five minutes, test that there is a "pull" on the flue by placing a smoke match, cigarette or similar device which gives off smoke, in front of the spill tube. See diagram 17.1.

Check for proper draft by placing a match close to the drafthood opening. This should be checked after the unit has been operating for 15 min.

The smoke should be drawn into the Drafthood. If the smoke is still not drawn into the Drafthood turn the unit off and check for the cause of the lack of draft. If necessary, seek expert advice. For wind turbulent sites, a wind cap may remedy the problem.

**Note: The thermally activated safety switch will sense the change in temperature and shut down the gas valve in the event of a severe downdraft or a blocked or disconnected vent. The switch acts as a safety shut-off to prevent a build-up of carbon monoxide. If the flue is blocked or has no "draw", the switch will automatically shut off the supply of gas within 5 - 10 minutes. Tampering with the switch can result in carbon monoxide (CO) poisoning and possible death.**

**If the heater turns off because of lack of draft during the spillage test, check for the cause and if necessary, seek expert advice.**

**The thermally actuated safety switch will automatically reset after it has cooled off. The switch will continue to cycle until the draft problem is corrected. DO NOT BYPASS OR DISCONNECT THIS SWITCH.**

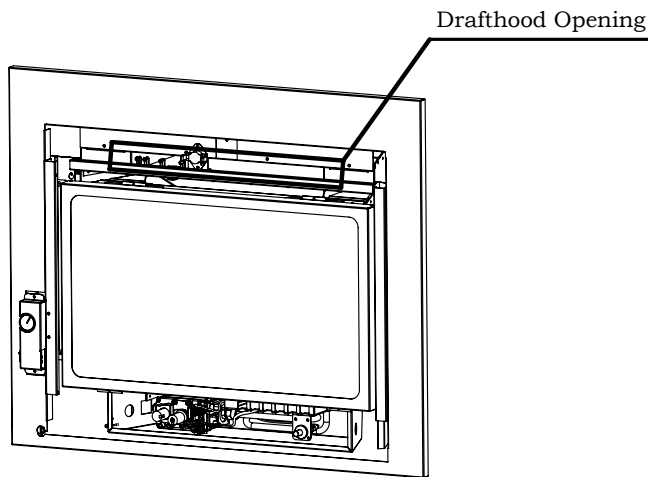

E18 Shown with front faceplate removed

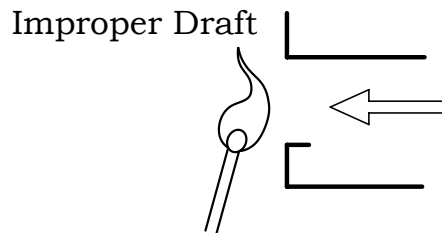
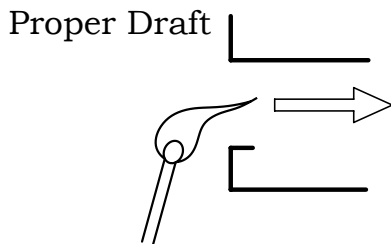

Diagram 17.1

**SAFETY SWITCHES**

The E18E uses two safety switches to maintain proper operation.

The first is a Spill Switch which will shut off the appliance if continuous spilling of exhaust gas from the draft hood occurs. The spill switch will shut off the Main Burner but not the Pilot. This switch resets automatically, if the problem persists the appliance will cycle on and off. If this occurs, shut the unit off and contact a technician.

The second is a Primary Limit Switch. This switch confirms that the circulation fan is operating normally. If for any reason the circulation fan fails, the Primary Limit Switch will turn off the Main Burner but not the Pilot before the appliance becomes too hot. This switch is automatic resetting, so if the problem persists you will see your appliance cycling on and off. If this occurs shut the unit off and contact a technician.

**OPERATION CONTROLS**

**FIREPLACE CONTROLS**

The E18E has 3 controls for controlling flame height, fan speed and flame on/off. The fan on the E18E is designed to come on once the fireplace has reached a pre-determined temperature, and to go off once the temperature has dropped following use.

The speed of the fan can be varied by adjusting the Fan Speed Control dial up or down. These controls are located to the left side of the Surround Panels. Providing that the pilot system is in standing mode, the main burner can be turned on or off by way of a switch located just below the Fan Speed Control dial.

See the Lighting Instruction section in this manual for information on lighting the pilot.

The flame height can be adjusted from minimum to maximum by way of an adjustment knob on the Control Valve, located behind the Access Panel.

The Access Panel is held in place by magnets and can simply be lifted away from the unit and set aside.

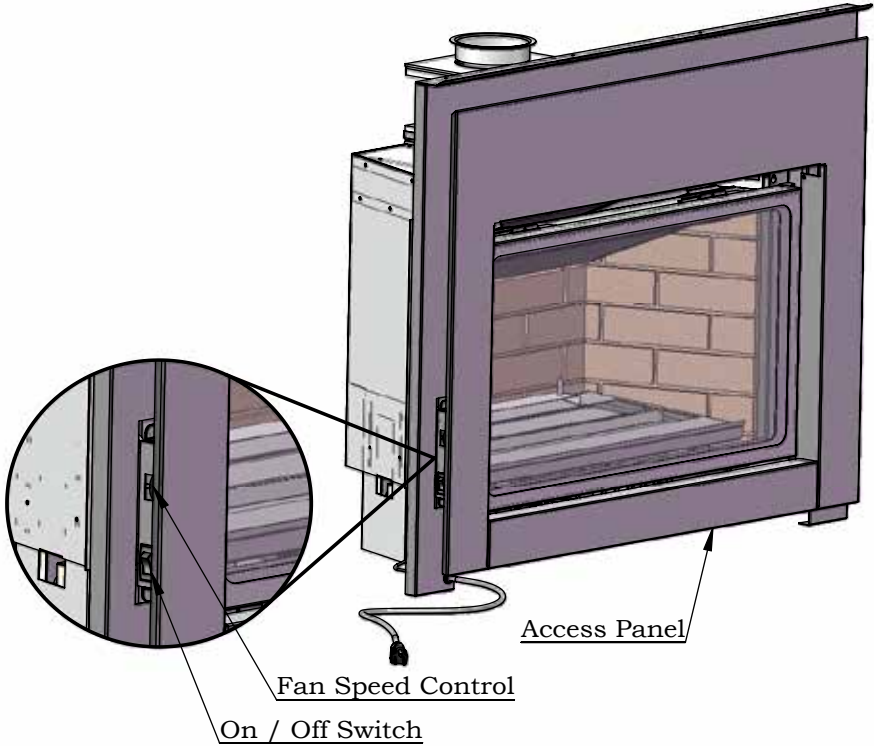

Flame control

Diagram 18.1

## COPY OF THE LIGHTING PLATE INSTRUCTIONS

### FOR YOUR SAFETY READ BEFORE LIGHTING POUR VOTRE SÉCURITÉ – À LIRE AVANT LA MISE EN MARCHÉ

**WARNING:** If you do not follow these instructions exactly, a fire or explosion may result causing property damage, personal injury or loss of life. Improper installation, adjustment, alteration, service or maintenance can cause injury or property damage. Refer to the owner's information manual provided with this appliance. For assistance or additional information consult a qualified installer, service agency or gas supplier.

**AVERTISSEMENT :** Quiconque ne respecte pas scrupuleusement les instructions de la présente notice risque de déclencher un incendie ou une explosion pouvant entraîner des dégâts matériels ou des blessures pouvant être mortelles. Tout défaut d'installation, de réglage, de modification, de service ou d'entretien peut entraîner des blessures ou des dommages matériels. Reportez-vous au manuel d'utilisation fourni avec cet équipement. Pour obtenir de l'aide ou des informations complémentaires, consulter un installateur ou un service d'entretien qualifié, ou le fournisseur de gaz.

- A) This appliance is equipped with an ignition device which automatically lights the pilot.  
Do not try to light the pilot by hand.
- B) **BEFORE OPERATING** smell all around the appliance area for gas. Be sure to smell next to the floor because some gas is heavier than air and will settle on the floor.  
**WHAT TO DO IF YOU SMELL GAS**  
- Do not try to light any appliance.  
- Do not touch any electric switch, do not use any phone in your building.  
- Leave the building immediately.  
- Immediately call your gas supplier from a neighbours phone. Follow the gas supplier's instructions.  
- If you cannot reach your gas supplier, call the fire department.
- C) Do not use this appliance if any part has been under water. Immediately call a qualified service technician to inspect the appliance and to replace any part of the control system and any gas control which has been underwater.
- A) Cet appareil est muni d'un dispositif d'allumage qui allume automatiquement la veilleuse.  
Ne tentez pas d'allumer la veilleuse manuellement.
- B) **AVANT LA MISE EN MARCHÉ**, reniflez tout autour de l'appareil pour détecter une odeur de gaz. Reniflez au niveau du plancher, car certains gaz sont plus lourds que l'air et peuvent s'accumuler au niveau du sol.
- QUE FAIRE SI VOUS SENTEZ UNE ODEUR DE GAZ :**
- Ne tentez pas d'allumer l'appareil
  - Ne touchez à aucun interrupteur; n'utilisez pas le téléphone se trouvant dans le bâtiment.
  - Quittez immédiatement le bâtiment.
  - Appelez immédiatement votre fournisseur de gaz depuis un téléphone extérieur. Suivez les instructions du fournisseur.
  - Si vous ne pouvez pas rejoindre le fournisseur, appelez le service incendie.
- C) N'utilisez pas cet appareil s'il a été plongé dans l'eau, même partiellement. Faites inspecter l'appareil par un technicien qualifié et remplacez tout élément du système de contrôle ou de commande qui a été plongé dans l'eau.

**CAUTION:** Hot while in operation. Do not touch. Severe burns may result. Due to high surface temperatures keep children, clothing and furniture, gasoline and other liquids having flammable vapors away. Keep burner and control compartment clean. See installation and operating instructions accompanying appliance.

**ATTENTION :** Surfaces chaudes lorsque l'appareil est en marche. Ne pas toucher. Risque de brûlures graves. En raison des températures élevées, les enfants, les vêtements et le mobilier, le carburant et tout autre liquide aux vapeurs inflammables doivent être tenus éloignés de l'appareil. Nettoyer régulièrement le brûleur et le compartiment des commandes. Voir les consignes d'installation et d'utilisation fournies avec l'appareil.

### OPERATING INSTRUCTIONS / CONSIGNES DE FONCTIONNEMENT

- 1) **STOP!** Read the safety information above on this label.
  - 2) Ensure the Main switch is in the ON position and/or the wall mounted battery holder (if equipped) is in the <REMOTE> position.
  - 3) Press and release the ON/OFF button on the remote handheld transmitter. An audible beep should be heard from the receiver. If not using the remote, the unit can also be turned on by sliding the battery holder switch to the <ON> position (if equipped).
  - 4) After approximately 4 seconds the spark ignition system will spark for 60 seconds to light the main burner.
  - 5) The unit will turn on.  
Note: The first attempt to ignition will last approximately 60 seconds. If there is no flame ignition (rectification) the board will stop sparking for approximately 35 seconds. After this wait time, the board will start a second try for ignition by sparking for approximately 60 seconds. If there is still no positive ignition after the second attempt the board will go into lock out.  
The system will need to be reset as follows (after going into lock out mode):  
a) Wait 5 minutes - turn the system off by pressing the ON/OFF button on the remote.  
b) After approximately 2 seconds press the ON/OFF button again.  
c) Unit will repeat step 2.
  - 6) If the appliance will not operate, follow the instructions, "To Turn Off Gas to Appliance" and call your service technician or gas supplier. This appliance is equipped with an on-demand pilot that shuts off after seven days.
- 1) **STOP!** Lisez les instructions de sécurité sur la portion supérieure de cette étiquette.
  - 2) S'assurer que le commutateur principal est en position ON et/ou que le bloc-piles mural (le cas échéant) est en position <REMOTE>.
  - 3) Appuyer sur la touche ON/OFF de la télécommande puis relâcher. Un bip sonore retentira depuis le récepteur. Si vous n'utilisez pas la télécommande, l'appareil peut également être allumé en faisant glisser le commutateur du bloc-piles sur la position <ON> (le cas échéant).
  - 4) Après environ 4 secondes, le système d'allumage produira une étincelle pendant 60 secondes pour allumer le brûleur principal.
  - 5) L'appareil s'allumera.  
Remarque : Au premier allumage, le système tente d'allumer les flammes pendant 60 secondes. Si l'essai est infructueux, le système fera une pause de 35 secondes. C'est ce qu'on appelle l'étape de rectification. Ce délai écoulé, le système tente à nouveau d'allumer les flammes en produisant des étincelles pendant 60 secondes. Si les flammes ne s'allument toujours pas, le système se met en mode verrouillage.  
Il faut alors le réinitialiser en suivant les étapes ci-dessous (pour le déverrouiller) :  
a) Attendre 5 minutes et éteindre l'appareil en appuyant sur la touche ON/OFF de la télécommande.  
b) Attendre 2 secondes et appuyer encore une fois sur la touche ON/OFF.  
c) L'appareil répètera l'étape 2.
  - 6) Si l'appareil ne fonctionne pas, suivez les instructions "Pour couper le gaz au niveau de l'appareil" et appelez un technicien qualifié ou votre fournisseur de gaz.
- Cet appareil est équipé d'une veilleuse sur demande qui s'éteint après sept jours.

### TO TURN OFF GAS TO APPLIANCE / POUR COUPER LE GAZ AU NIVEAU DE L'APPAREIL

- 1) Press the ON/OFF button on the remote or slide the wall mount switch to the "OFF" position.
- 2) If service is to be performed—you must disconnect power and shut off gas to the unit.
- 1) Appuyer sur la touche ON/OFF de la télécommande ou faites glisser l'interrupteur mural sur la position "OFF".
- 2) Lors de l'entretien de l'appareil, vous devez débrancher l'alimentation électrique et couper le gaz alimentant l'appareil.

**DO NOT REMOVE THIS INSTRUCTION PLATE**

**NE PAS ENLEVER CETTE ÉTIQUETTE D'INSTRUCTIONS**

919-649b

## OPERATING INSTRUCTIONS

- 1) Read and understand these instructions before operating this appliance.
- 2) Check to see that all wiring is correct and enclosed to prevent possible shock.
- 3) Check to ensure there are no gas leaks.
- 4) Make sure the glass in the door frame is properly positioned. Never operate the appliance with the glass removed.
- 5) Verify that the venting and cap are unobstructed.
- 6) Ensure that the brick panels are installed.
- 7) Verify log placement. If the pilot cannot be seen when lighting the unit, the logs have been incorrectly positioned.
- 8) The unit should never be turned off, and on again without a minimum of a 60 second wait.

During the first few fires, a white film may develop on the glass front as part of the curing process. The glass should be cleaned or the film will bake on and become very difficult to remove. Use a non-abrasive cleaner and NEVER clean the glass while it is hot.

## AERATION ADJUSTMENT

The air shutter can be adjusted by moving the adjusting wire up or down. The wire is accessed through the bottom louver opening. Open the air shutter for a blue flame or close for a yellower flame. The burner aeration is factory set but may need adjusting due to either the local gas supply or altitude.

### Minimum Air Shutter Opening:

<b>3/16"</b>	<b>Natural Gas</b>
<b>Fully open</b>	<b>Propane</b>

**CAUTION:** Carbon will be produced if air shutter is closed too much.

**Note:** Any damage due to carboning resulting from improperly setting the aeration controls is NOT covered under warranty.

**Note:** Aeration Adjustment should only be performed by an authorized FPI Installer at the time of installation or service.

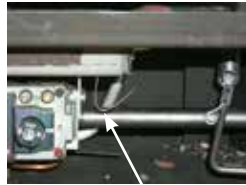

Adjustment wire: Push to close or pull to open aeration cap.

**Closed - Tall yellow**  
**Open - Short Blue**

## OPERATING INSTRUCTIONS

Before operating this appliance, proceed through the following check list.

1. **Read and understand these Instructions before operating this appliance.**
2. Check to see that all wiring is correct and enclosed to prevent possible shock.

## LIGHTING PROCEDURE

**NOTE: For all propane units and units equipped with electric spark boxes, see "Copy of Lighting Plate Instructions" section for more details.**

**IMPORTANT: Gas on/off knob cannot be turned from "PILOT" to "OFF" unless it is partially depressed.**

1. Open the bottom louver assembly.
2. If the control knob is in the "OFF" position proceed to Step 5.
3. Push in gas control knob slightly and turn clockwise to "OFF". Knob cannot be turned from "PILOT" to "OFF" unless knob is pushed in slightly. Do not force.

## FIRST FIRE

The first fire in your stove is part of the paint curing process. To ensure that the paint is properly cured, it is recommended that you burn your fireplace for at least four (4) hours the first time you use it with the fan on. When first operated, the unit will release an odour caused by the curing of the paint, the burning off of any oils remaining from manufacturing. Smoke detectors in the house may go off at this time. Open a few windows to ventilate the room for a couple of hours.

The glass panel may require cleaning after the unit has cooled down.

## DO NOT ATTEMPT TO CLEAN THE GLASS WHILE IT IS HOT.

**Do not use abrasive cleaners on the glass.**

**Note: When the glass is cold and the appliance is lit, it may cause condensation and fog the glass. This condensation is normal and will disappear in a few minutes as the glass heats up.**

## DO NOT BURN THE APPLIANCE WITHOUT THE GLASS FRONT IN PLACE.

## OPERATION

The fan operates automatically, turn the knob on the side of the faceplate to adjust to the desired speed. The fan will turn on as the stove comes up to operating temperature. After the unit has been turned off and the unit cooled to below a useful heat output range the fan will shut off automatically. This fan is required for normal operation. If the fan stops working at anytime the unit will automatically turn off after a delay of approximately 15-30 minutes.

## NORMAL OPERATING SOUNDS OF GAS APPLIANCES

It is possible that you will hear some sounds from your gas appliance. This is perfectly normal due to the fact that there are various gauges and types of steel used within your appliance. Listed below are some examples. All are **normal operating sounds** and should not be considered as defects in your appliance.

### Blower:

Regency® gas appliances use high tech blowers to push heated air farther into the room. It is not unusual for the fan to make a "whirring" sound when ON. This sound will increase or decrease in volume depending on the speed setting of your fan speed control.

### Burner Tray:

The burner tray is positioned directly under the burner tube(s) and logs and is made of a different gauge material from the rest of the firebox and body. Therefore, the varying thicknesses of steel will expand and contract at slightly different rates which can cause "ticking" and "cracking" sounds. You should also be aware that as there are temperature changes within the unit these sounds will likely re-occur. Again, this is normal for steel fireboxes.

### Blower Thermodisc:

When this thermally activated switch turns ON it will create a small "clicking" sound. This is the switch contacts closing and is normal.

### Pilot Flame:

While the pilot flame is on it can make a very slight "whisper" sound.

### Gas Control Valve:

As the gas control valve turns ON and OFF, a dull clicking sound may be audible, this is normal operation of a gas regulator or valve.

### Unit Body/Firebox:

Different types and thicknesses of steel will expand and contract at different rates resulting in some "cracking" and "ticking" sounds will be heard throughout the cycling process.

## MAINTENANCE INSTRUCTIONS

1. Always turn the gas valve to off before cleaning. For relighting, refer to lighting instructions. Keep the burner and control compartment clean by brushing and vacuuming at least once a year.

When cleaning the logs, use a clean soft paint brush as the logs are fragile and easily damaged.

2. Clean (never when unit is hot) appliance, door and louvers with a damp cloth. Never use an abrasive cleaner. The gold louvers (and optional gold door) may be scratched if abrasives are used to clean them.

The heater is finished in a heat resistant paint and should only be refinished with heat resistant paint (not with wall paint). Regency® uses StoveBrite Paint - Metallic Black #6309.

3. Make a periodic check of burner for proper position and condition. Visually check the flame of the burner periodically, making sure the flames are steady; not lifting or floating. If there is a problem, call a qualified service person.

4. The appliance and venting system must be inspected before use, and at least annually, by a qualified field service person, to ensure that the flow of combustion and ventilation air is not obstructed.

During the annual service call, the burners should be removed from the burner tray and cleaned. Replace the embers but do not block the pilot.

5. Keep the area near the appliance clear and free from combustible materials, gasoline and other flammable vapours and liquids.

6. Each time the appliance is lit, it may cause condensation and fog the glass. This condensation and fog is normal and will disappear in a few minutes as the glass heats up.

**Never operate the appliance without the glass properly secured in place or with the door open.**

7. Verify proper operation after servicing.
8. Periodically check the pilot flames, see the diagrams in the "Valve Description" section. If you have an incorrect flame pattern, contact your Regency® dealer for further instructions.

**WARNING: CHILDREN AND ADULTS SHOULD BE ALERTED TO THE HAZARDS OF HIGH SURFACE TEMPERATURE AND SHOULD STAY AWAY TO AVOID BURNS OR CLOTHING IGNITION. YOUNG CHILDREN SHOULD BE CAREFULLY SUPERVISED WHEN THEY ARE IN THE SAME ROOM AS THE APPLIANCE.**



**CAUTION: ANY SAFETY SCREEN OR GUARD REMOVED FOR SERVICING AN APPLIANCE MUST BE REPLACED PRIOR TO OPERATING THE APPLIANCE.**

**CLOTHING OR OTHER FLAMMABLE MATERIAL SHOULD NOT BE PLACED ON OR NEAR THE APPLIANCE.**

## LOG REPLACEMENT

The unit should never be used with broken logs. Turn off the gas valve and allow the unit to cool before opening door to carefully remove the logs. The pilot light generates enough heat to burn someone. If for any reason a log should need replacement, you must use the proper replacement log. The position of these logs must be as shown in the diagram under Log Installation.

**NOTE: Improper positioning of logs may create carbon build-up and will alter the unit's performance which is not covered under warranty.**

## DOOR GLASS

Your Regency® fireplace is supplied with high temperature 5mm-Ceramic glass. If your glass requires cleaning, we recommend using an approved glass cleaner available at all authorized dealers. Do not use abrasive materials.

### CAUTION & WARNINGS:

- \* Do not clean when the glass is hot.
- \* The use of substitute glass will void all product warranties.
- \* Care must be taken to avoid breakage of the glass.
- \* Do not strike or abuse the glass.
- \* Do not operate this fireplace without the glass front or with a cracked or broken glass front.
- \* Wear gloves when removing damaged or broken glass.
- \* Replacement of the glass panels should be done by a licensed or qualified service person.

## GLASS REPLACEMENT

In the event that you break your glass by impact, purchase your replacement from an authorized Regency dealer only. Replacement glass (Part #616-518/P) is shipped already installed into the door frame. Reinstall as per Glass Door Installation in the "Glass Door Removal" section.

# maintenance

## VALVE REPLACEMENT

1. **Shut off the gas and electrical supply.**
2. Remove Faceplate Control Cover (see instructions in manual).
3. Remove Glass Door (see instructions in manual).
4. Remove Log Set and Embers or crystals and stones (if installed).
5. Remove Burner and Panels (see instructions in this manual).
6. Unplug the Orange, Green, and Ground wires on the front of the Valve.

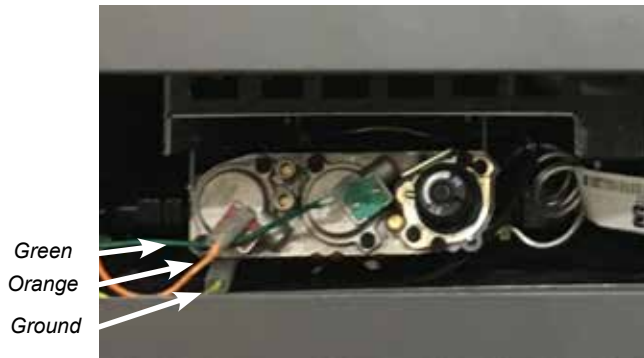

Diagram 19.1

## INSTALLING VALVE

1. Place new valve tray and gasket into position.
2. Reverse Steps 9-1.
3. Check for gas leaks.

7. Unscrew the 8 screws holding down the Valve Tray.
8. Slide the Valve Tray out about half way giving easier access to the gas connection at the valve.

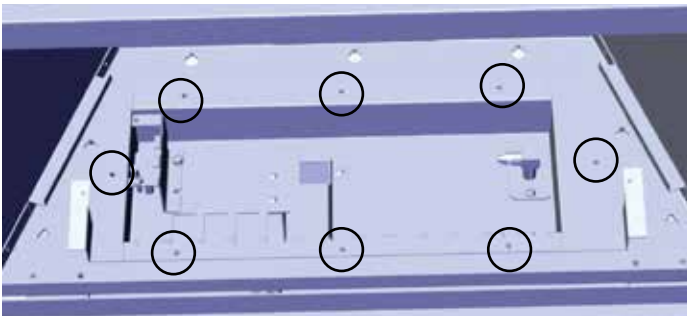

Diagram 19.2

9. Disconnect the gas line and remove the valve tray.



Diagram 19.3

## REMOVING THE FAN

**IMPORTANT**  
**Disconnect power supply**  
**before servicing.**

1. Shut off the gas and electrical supply.
2. Remove Control Cover. (see instructions in manual)
3. Remove Glass Door.(see instructions in manual)
4. Remove Log Set and Embers or crystals and stones (if installed).
5. Remove Burner and Panels (see instructions in manual)
6. Remove Valve Tray - see previous page.
7. Disconnect Ground Wires and unclip Safety Circuit Wires and remove through Grommet .

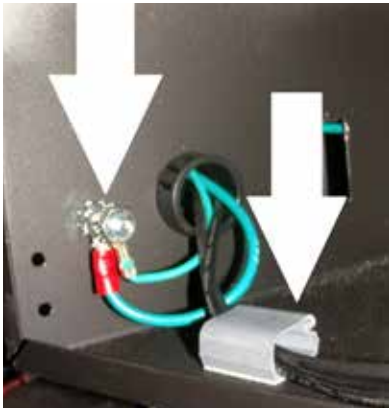

Diagram 20.1

8. Remove 4 screws holding in Air Inlet Baffle and remove it.
9. Loosen 3 screws holding in the Circulation Fan.
10. Disconnect Power Leads on Fan Motor

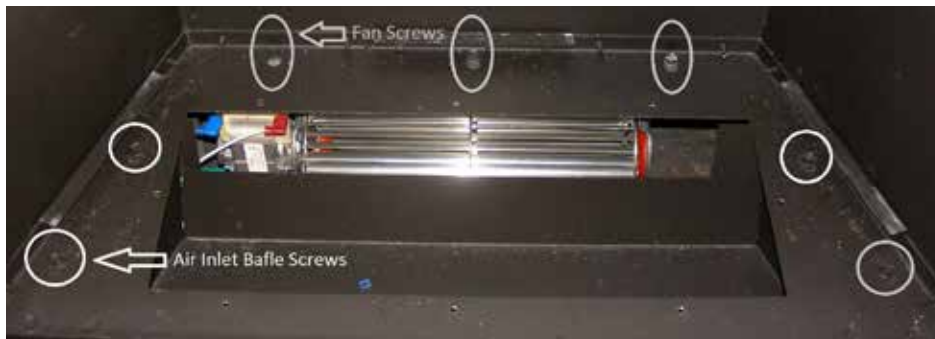

Diagram 20.2

11. Reverse Steps to reinstall.

# maintenance

## WIRING DIAGRAMS

This heater requires a 120V A.C. supply for operation of the circulation fan which is required for operation of the fireplace. In case of a power failure, the fireplace can be turned on but a thermal safety switch will cut out the appliance before it gets too hot. The unit will cycle on and off as required to stay within temperature specifications.

**Caution: Ensure that the wires do not touch any hot surfaces and are away from sharp edges.**

When connected with 120 volts, the appliance must be electrically grounded in accordance with local codes or, in the absence of local

codes the current CSA C22.1 (in Canada) or with the National Electrical Code ANSI/NFPA 70-1987 (in USA).

**NOTE: This unit is equipped with a heat sensor thermdisc which will prevent the blower from operating until the unit reaches the correct temperature.**

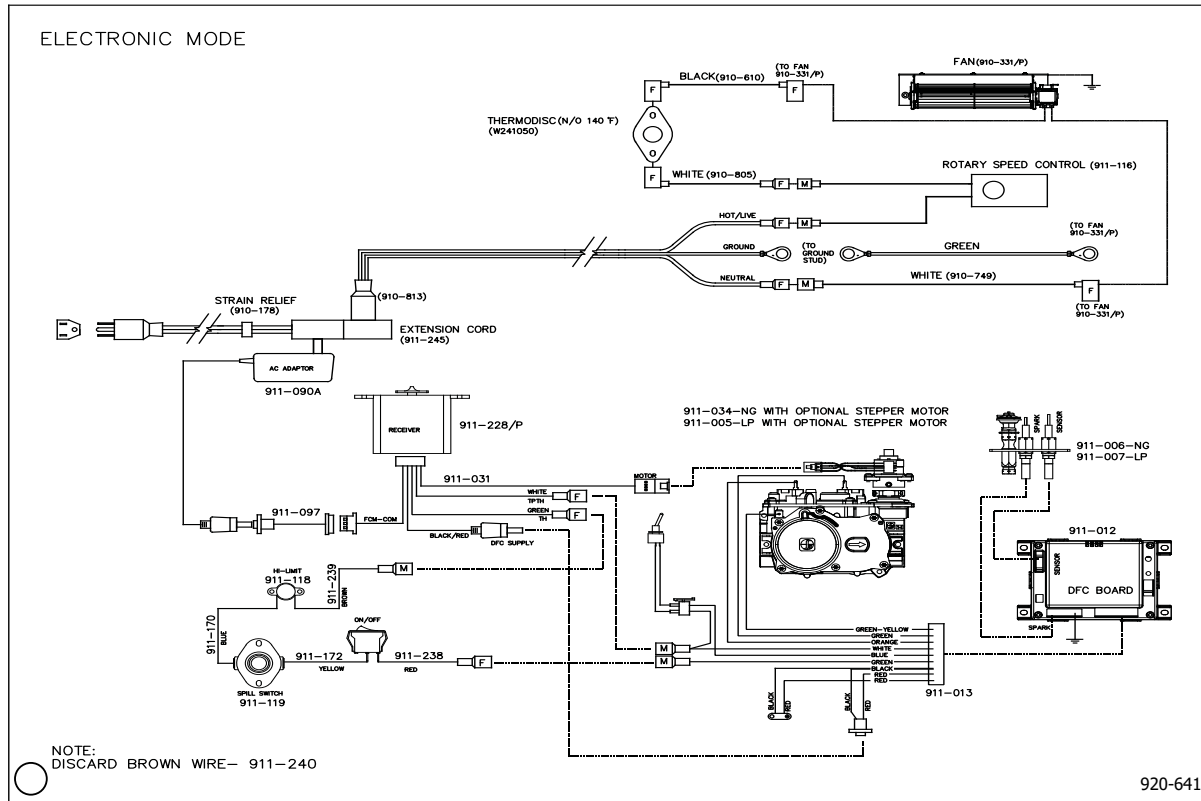

**CAUTION:** Label all wires prior to disconnection when servicing controls. Wiring errors can cause improper and dangerous operation.

**WARNING: Electrical Grounding Instructions**

This appliance is equipped with a three pronged (grounding) plug for your protection against shock hazard and should be plugged directly into a properly grounded three-prong receptacle. Do not cut or remove the grounding prong from this plug.

Diagram 21.1

## WIRING DIAGRAMS

(Do not cut the ground terminal off under any circumstances.)

Fan must always operate with this unit.

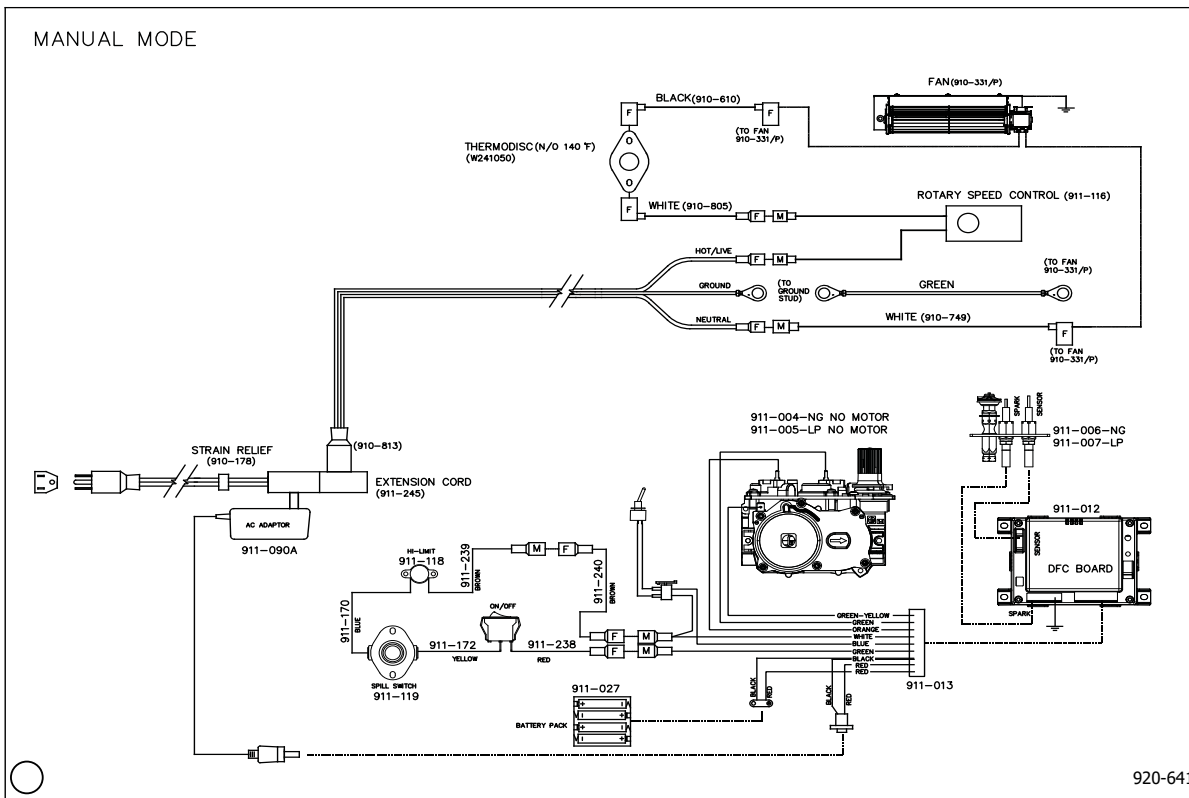

Diagram 21.2

1. Remove wire labelled 911-240 in diagram above for GTM Remote and thermostat installation.
2. Remote and thermostat must be wired in series.

# maintenance

## GAS MAINTENANCE - RECOMMENDED ANNUAL ROUTINE

In order for your Regency appliance to continue to provide comfort to your home periodic maintenance must be performed to ensure it is operating at peak efficiency. The items in the list should be checked by a licensed gas service technician during the annual service check. Your unit may require more frequent maintenance checks if you notice any changes in how it operates. Operational changes to look for can include, but are not limited to, extended start up time, increased fan noise, residue/carbon build up, white build up on the glass/firebox, increased operating noise etc. Should any of these or other conditions arise, discontinue use and schedule a service check with your local licensed gas technician. The list below shows items your licensed service technician will need to check and service at least annually.

### Clean

- Glass
- Interior bricks / panels
- Burner ports & burner air shutter
- Fan blades
- Log set
- Pilot orifices
- Pilot hood (change as needed)
- Flame sensor (electronic ignition models)
- Flame electrode
- Burner orifice
- Thermocouple (millivolt models)
- Thermopile (millivolt models)

### Inspect

- Pilot assembly
- Burner
- Pressure relief gaskets/doors
- Flue connector gasket if present
- Door seal
- Firebox
- Venting
- Batteries (remote handheld, remote receiver, DC sparker, change as needed)
- Burner media (change as needed)
- Air shutter setting
- Wiring

### Check

- Voltage on thermocouple/thermopile (millivolt models)
- Ohms reading on flame sense (electronic ignition models)
- Inlet/outlet fuel pressures as per rating plate
- Voltage/ohms readings on gas valve
- Ohms reading to on/off switch circuit (Millivolt models)

### Gas Leak Tests

- Check main gas line connection to valve
- Check shut off valve connections
- Check connection at gas valve outlet
- Check connection at main burner orifice
- Check pilot fuel line at valve and at pilot assembly

## MAIN ASSEMBLY

1	617-574/P	Valve Assembly - NG
1	617-776/P	Valve Assembly - LP
3	911-004	Valve Only - NG 886 SIT IPI High/Low 0.886.002
3	911-005	Valve Only - LP 886 SIT IPI High/Low 0.886.003
5	911-006	Pilot Assembly IPI NG 2 Flame 0.199.050
5	911-277	Pilot Assembly IPI LP 2 Flame
6	910-100	Pilot Orifice NG #62 977.166
6	910-037	Pilot Orifice LP #30 977.167
9	904-943	Bracket Dormont Orifice Mount 10-BZ001-19.5
10	904-974	Burner Orifice #44 NG (PO512)
10	904-977	Burner Orifice #55 LP (PO512)
11	911-038	Spark Electrode Cable Black End 0.915.020
12	911-037	Sense Electrode & Cable Red End 0.915.905
13	911-039	Pilot Hood 2 Flame Sit SureFire0.975.005
14	911-008	Novasit Regulator NG For 886 SIT 907.014
14	911-009	Novasit Regulator LP For 886 SIT 907.014
15	911-265	Ignition Board (DFC) SIT IPI 0.584.622
17	911-118	High Limit Switch 36T21 22583
18	911-119	Spill Switch 60T11 610021
19	W241050	Fan Thermodisc 60T12-610049
20	616-517/P	Fan Assembly Complete
21	910-331/P	Blower Motor only - Includes Squirrel Cage
22	616-518/P	Flush Door Glass Assembly Complete
23	616-529	Safety Screen
24	617-006	Spill Switch Bracket
25	616-515	Log Tray Assembly
N/S	904-978	Inlet Flex Line Gas SS Steel 18" Black
N/S	904-165	Fitting 3/8 Male Flarex Mpt Strt Adaptor
N/S	904-599	Fitting Elbow 90 Degree
N/S	911-138	Thermostat Digital Non-Programmable
N/S	910-246	Switch 2 Way Gold Contact
N/S	616-525	Burner Assembly NG/LP
N/S	910-432	Pilot Tube 1/8 x 24 w/ Steel Fittings
N/S	904-529	Allen Key 5/32 Long
N/S	911-013	Wire Harness Inc. Grn IP/CP Swth 584.912
N/S	910-610	Black Wire FanTerminal Block To Switch
N/S	910-749	White Wire Fan
N/S	910-805	White Wire Thermodisc To Swtich
N/S	911-116	Speed Control Fan w/ Connectors E18
N/S	911-170	Blue Wire To Spill Switch to High Limit
N/S	911-172	Yellow Wire Thermodisc To Switch
N/S	911-245	Extension Cord
N/S	911-238	Red Wire Switch To Harness
N/S	911-239	Brown Wire Coupling to High Limit
N/S	911-240	Brown Wire Coupling
N/S	910-592	Hand Held Remote Control GTMF SIT 0.584.023
N/S	911-031	Wire Harness FCM Pwr 750mm LgCom 584.905

N/S	911-228/P	Remote Receiver With Antenna Connect 0.584.525
N/S	911-210	External Antenna
N/S	918-835	Decal Logo Regency / Flame Sit Remote
N/S	918-875	Decal Remote Quick Reference GTM
N/S	904-569	Knob Fan Speed Control
N/S	910-813	Power Cord 120 Volts
N/S	904-836	Glass Nut Retainer 1/4-20 J Type Zinc Plt
N/S	904-839	Glass Screw 1/4-20 x 1 inch Pan Hd Phil Blk
N/S	616-004	Firebox Baffle
N/S	616-051	Valve Control Cover
N/S	616-057	Brick Panel Support Bracket (Each)
N/S	616-071	Fan/On Off Switch Bracket
N/S	616-072	Burner Cover Plate
N/S	616-523	Flue Collar Assembly
N/S	616-078	Enamel Clip (Each)
N/S	617-507	Manual Package Complete
N/S	919-788	Instruction Manual
Optional Accessories		
	946-710	Volcanic Stones -Slate/Grey Basalt Natural 15 pound box
	946-711	Volcanic Stones - Ivory/Tan Basalt Natural 15 pound box
	946-674	Ceramic Spa Stones
	616-901	Brick Panel Standard Brown
	616-902	Brick Panel Standard Red
	616-908	Inner Panel Black Enamel
	616-910	Flue Adaptor (FS220N,EP28F,EP28-4/5/C)
	616-911	Flue Adaptor (36SR)
	616-920	Faceplate Low Profile. (FS220N)
	616-921	Faceplate Low Profile (EP28F/28F-2/28F-3)
	616-924	Faceplate Low Profile(EP28-4/5/C)
	616-926	Faceplate Low Profile (36SR)
	616-928	Faceplate Low Profile (FS120)
	616-931/P	Log Set E18 Driftwood Packaged
	616-935	Log Set & Tray Pkgd E18
	616-940	Faceplate Custom Low Profile. (FS220N)
	946-775	Fireglass Black Reflective 1/4in.5Lb
	946-776	Fireglass Copper 1/4 in. 5Lb
	946-777	Fireglass Starfire 1/4 in. 5Lb
	617-950	Remote-Proflame GTM
	617-977	Conversion Kit - LP
	617-948	Faceplate Low Profile (ZC Installation) Mt. Blk E18E

# parts list

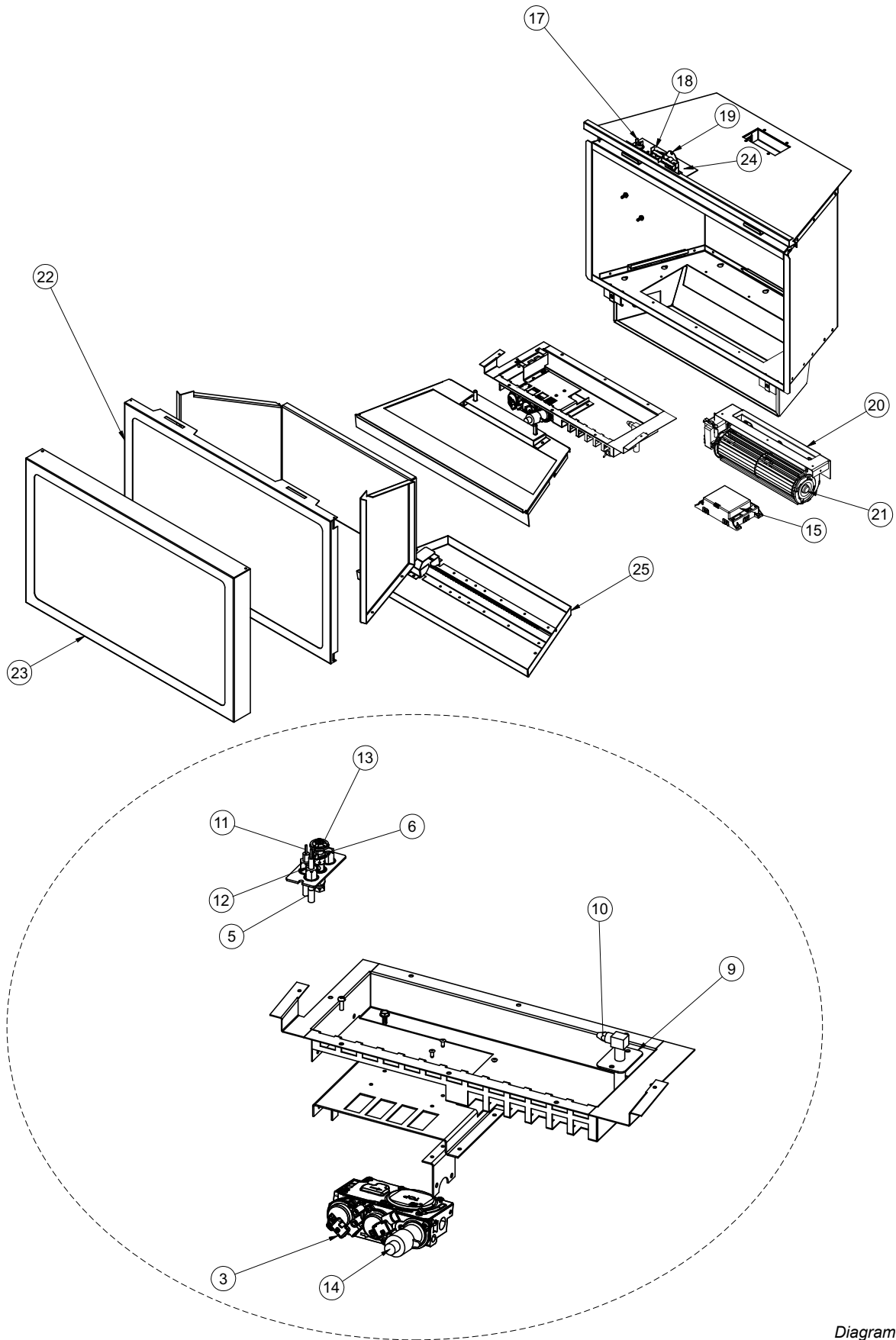

Diagram 22.1



### EP28 Installation Kit

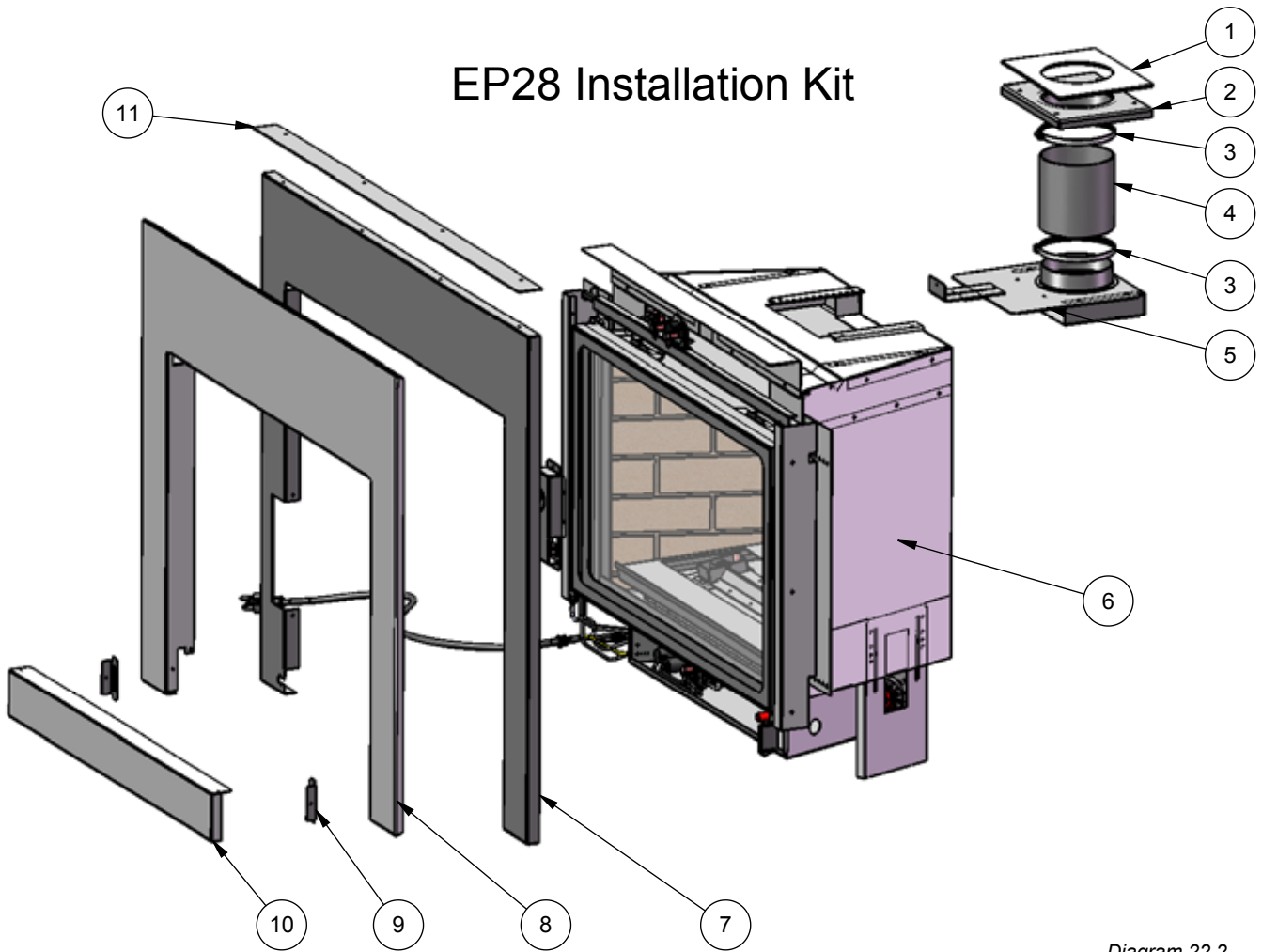

Diagram 22.2

Part #	Description	Part #	Description
1	616-070 Adaptor plate gasket	6	E18E Body
2	616-069 Adaptor plate	7	616-068 Surround Panel Rear
3	904-960 Ring clamp -Installer supplied	8	616-067 Surround Front
4	948-338 Flex Vent Section - Installer supplied	9	Magnet and Bracket
5	616-023 Flue Slider Plate	10	616-051 Control Cover
		11	Upper Trim/ heat shield

# parts list

## Montigo Econo Plus 28C Installation Kit

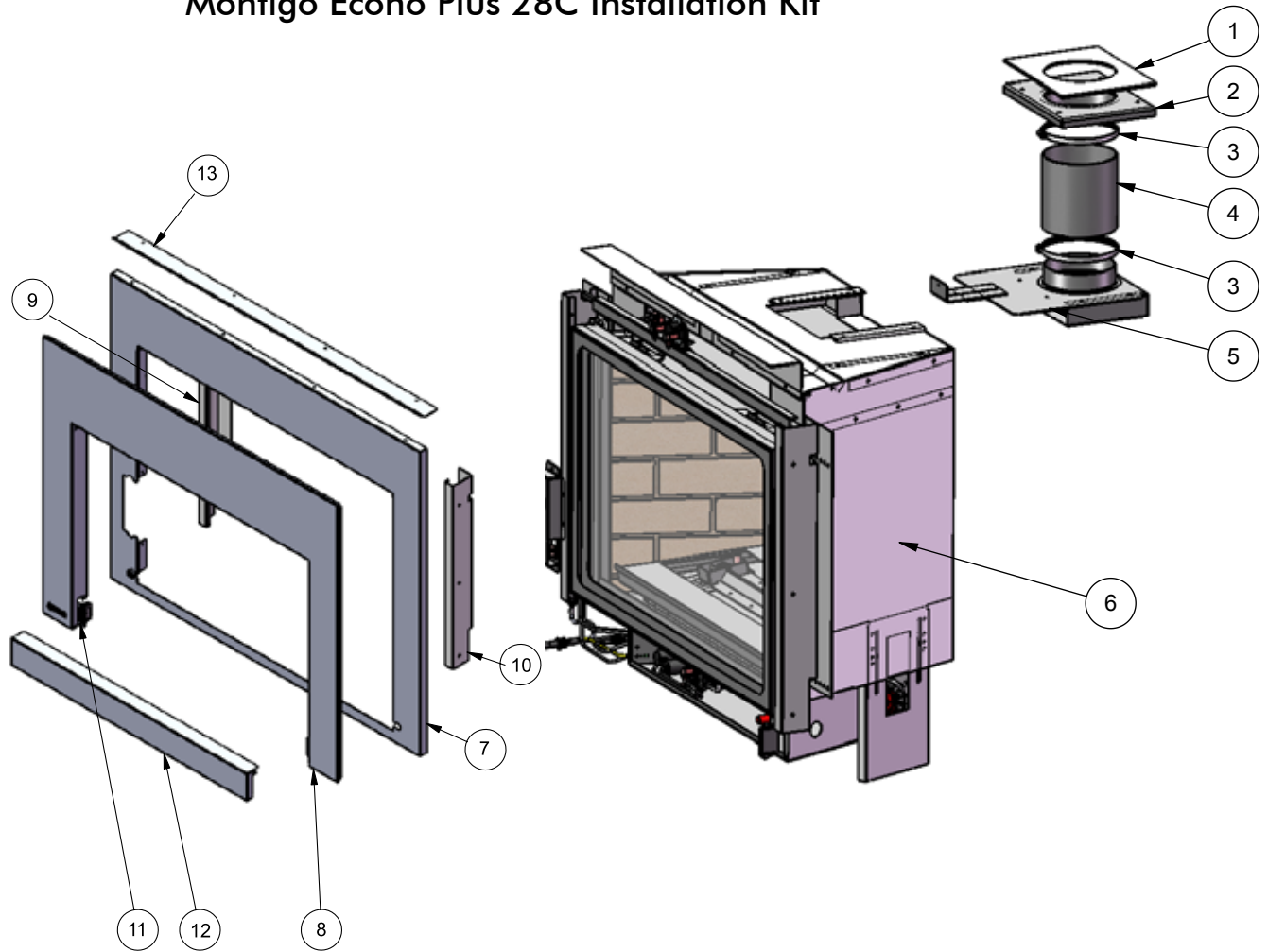

Diagram 22.3

Part #	Description	Part #	Description		
1	616-070	Adaptor plate gasket	6	E18E Body	
2	616-069	Adaptor plate	7	616-049	Surround Panel Rear
3			8	616-050	Surround Front
			9	616-048	Faceplate Hanger Left
			10	616-048	Faceplate Hanger Right
4	904-960	Ring clamp -Installer supplied	11	904-057	Magnet and Bracket
5	948-338	Flex Vent Section - Installer supplied	12	616-051	Control Cover
	616-023	Flue Slider Plate	13	616-053	Upper Trim/ heat shield - remove and discard

## Montigo 28-F & 28F-2 Installation Kit

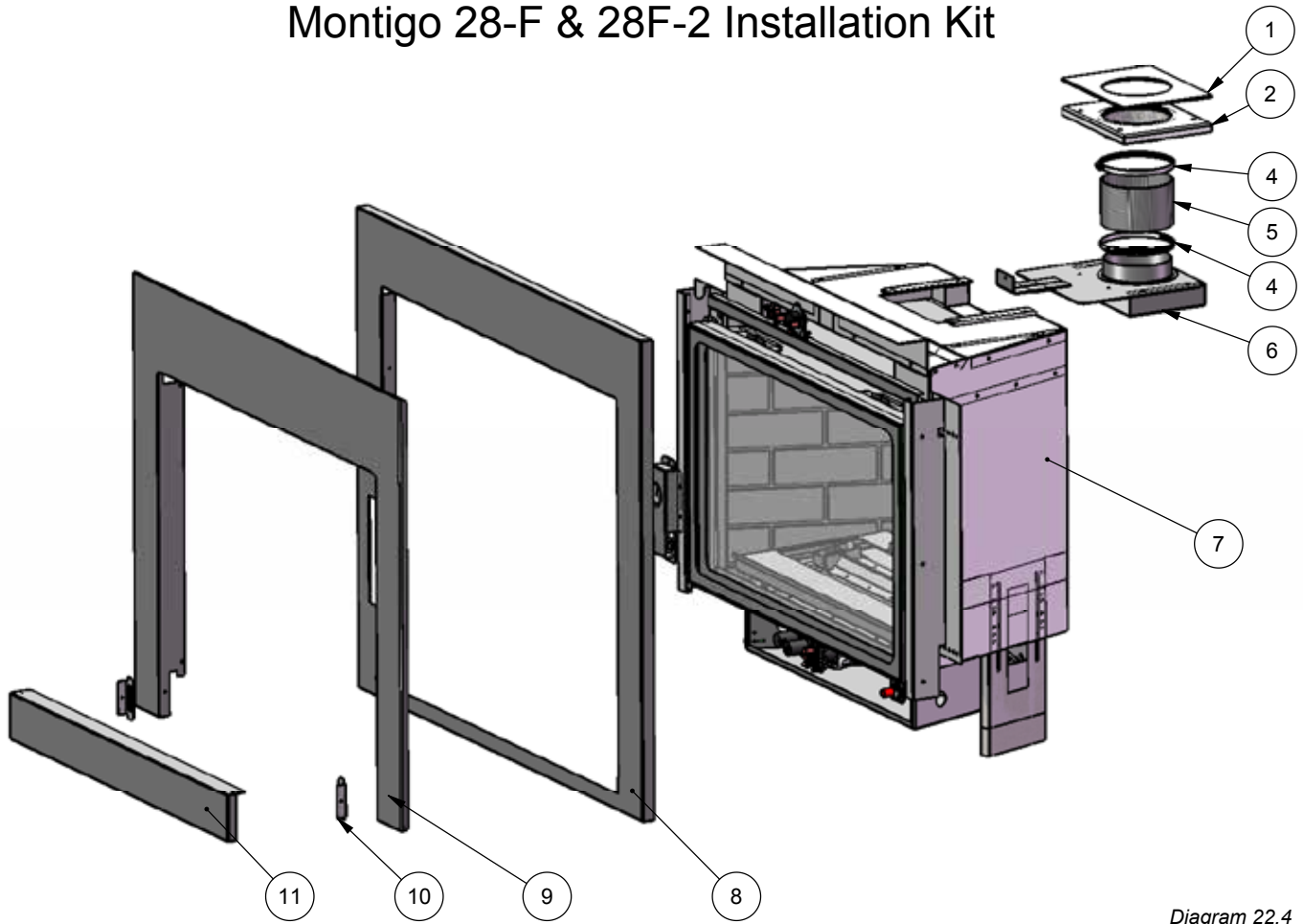

Diagram 22.4

Part #	Description	Part #	Description
1	616-070 Adaptor plate gasket	7	E18E Body
2	616-069 Adaptor plate	8	616-068 Surround Panel Rear
3		9	616-067 Surround Panel Right
4	904-960 Ring clamp -Installer supplied	10	Magnet and Bracket
5	948-338 Flex Vent Section - Installer supplied	11	616-051 Control Cover
6	616-023 Flue Slider Plate	12	

### Montigo 28-F3 Installation Kit

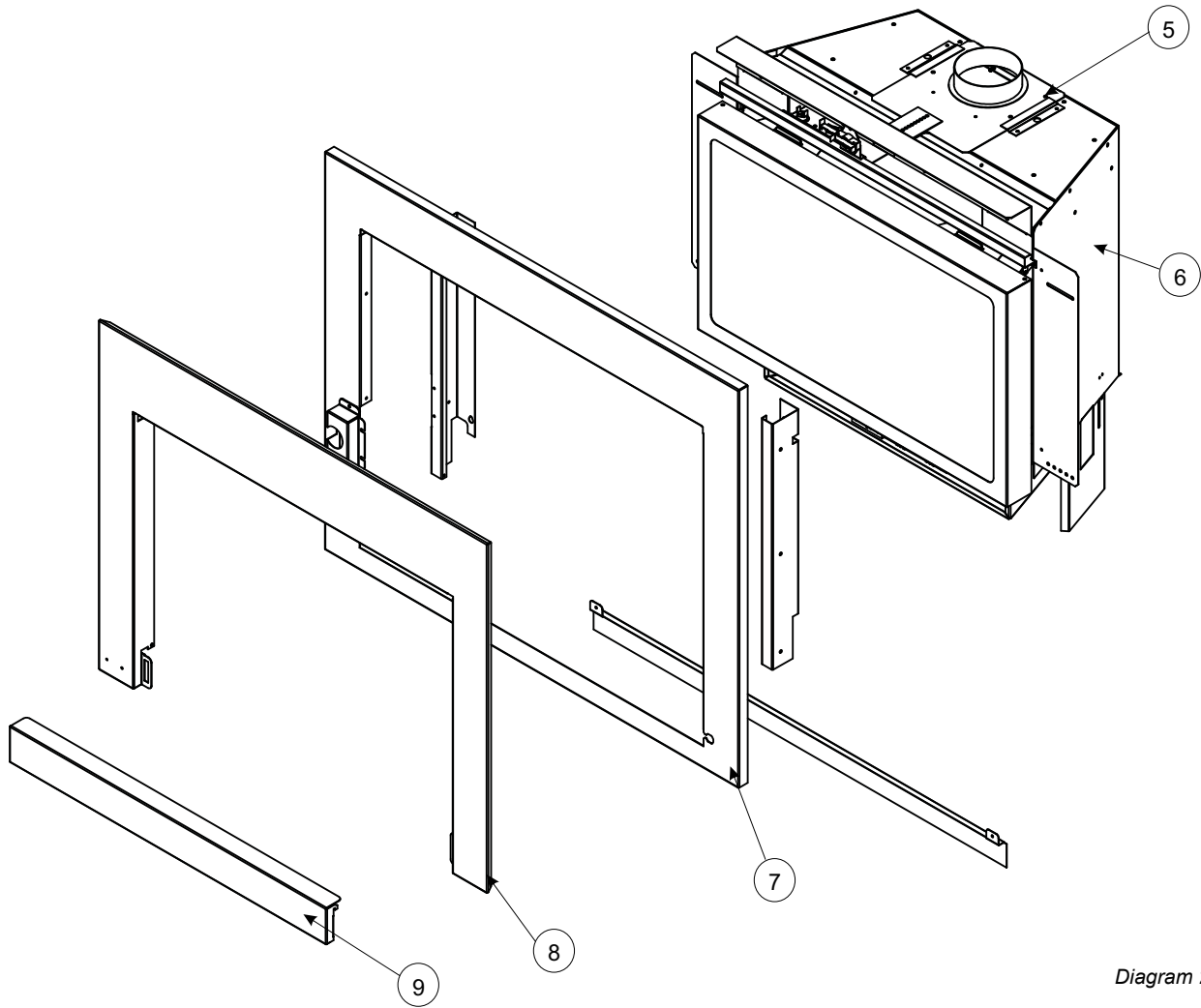

Diagram 22.5

Item	Part #	Description	Item	Part #	Description
			8		Faceplate panel Front
3		Ring Clamp	9		Magnet Bracket (not shown)
4		Flex section	10		Control Cover
5		Adaptor Slide Plate			
6		E18E Chassis			
7		Faceplate panel Rear			

Montigo 36SR Installation Kit  
(Requires 4" liner)

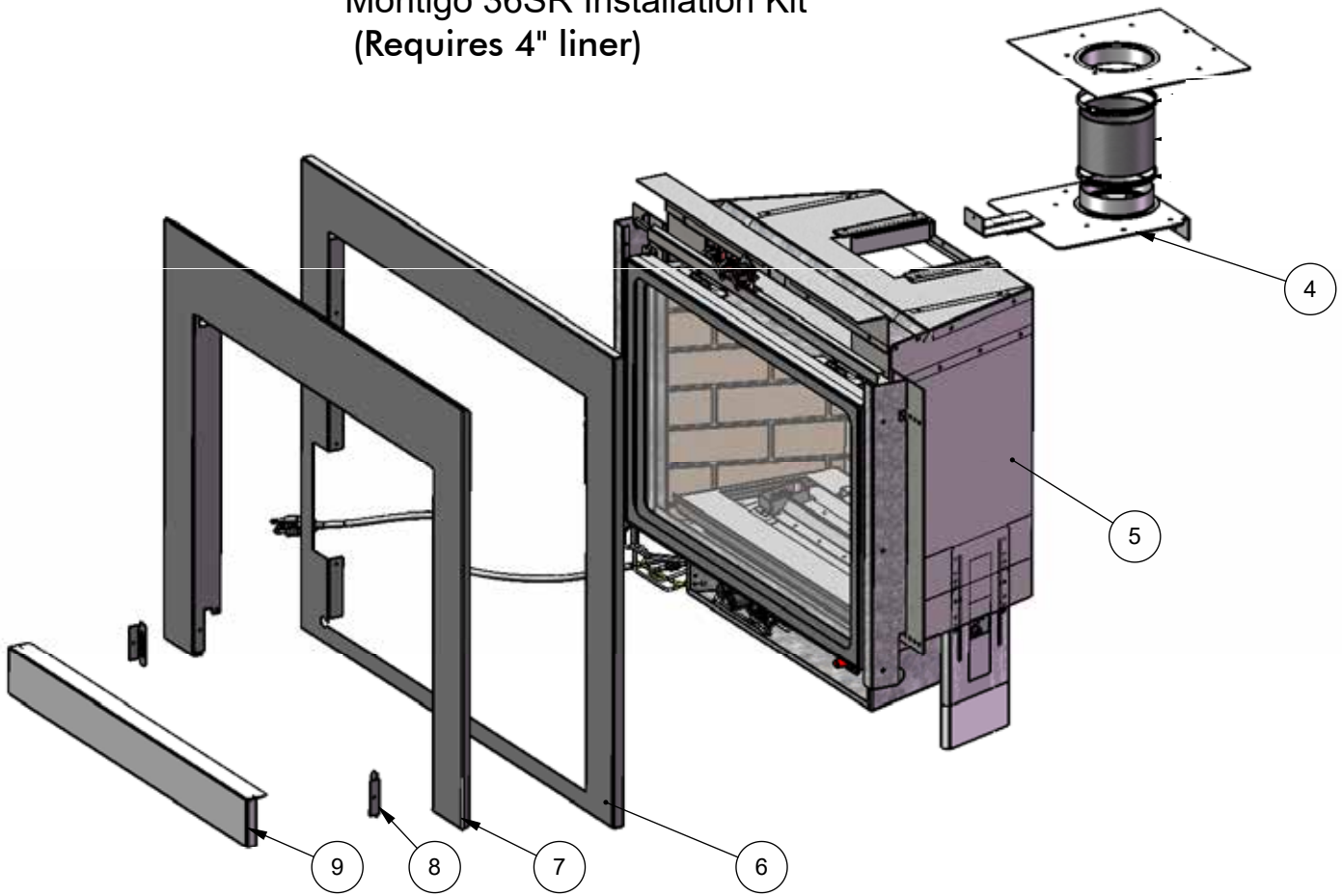

Diagram 22.6

Item	Part #	Description	Item	Part #	Description
			7		Surround panel Front
			8		Magnet Bracket (not shown)
			9		Control Cover
4		Adaptor Slide Plate			
5		E18E Chassis			
6		Surround Panel Rear			

## Firesong 220N Installation Kit

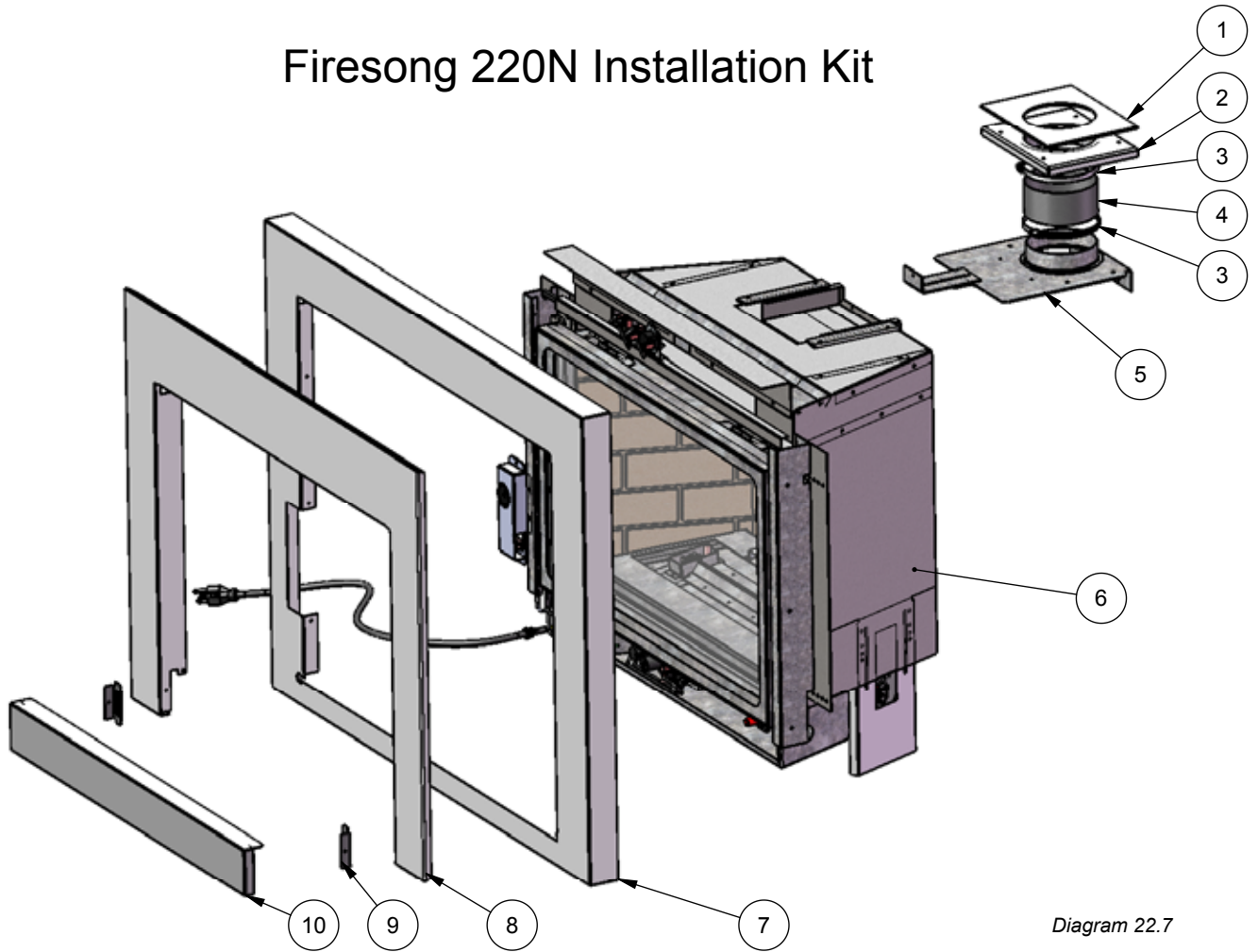

Diagram 22.7

Item	Part #	Description	Item	Part #	Description
1		Adaptor Plate Gasket	7		Surround Panel Rear
2		Adaptor Plate	8		Surround Panel Front
3		Ring Clamp - installer supplied	9		Magnet / bracket
4		Fex Section - installer support	10		Control Cover
5		Adaptor Slide Plate	11		
6		E18 Chassis	12		

### Firesong 120N Installation Kit

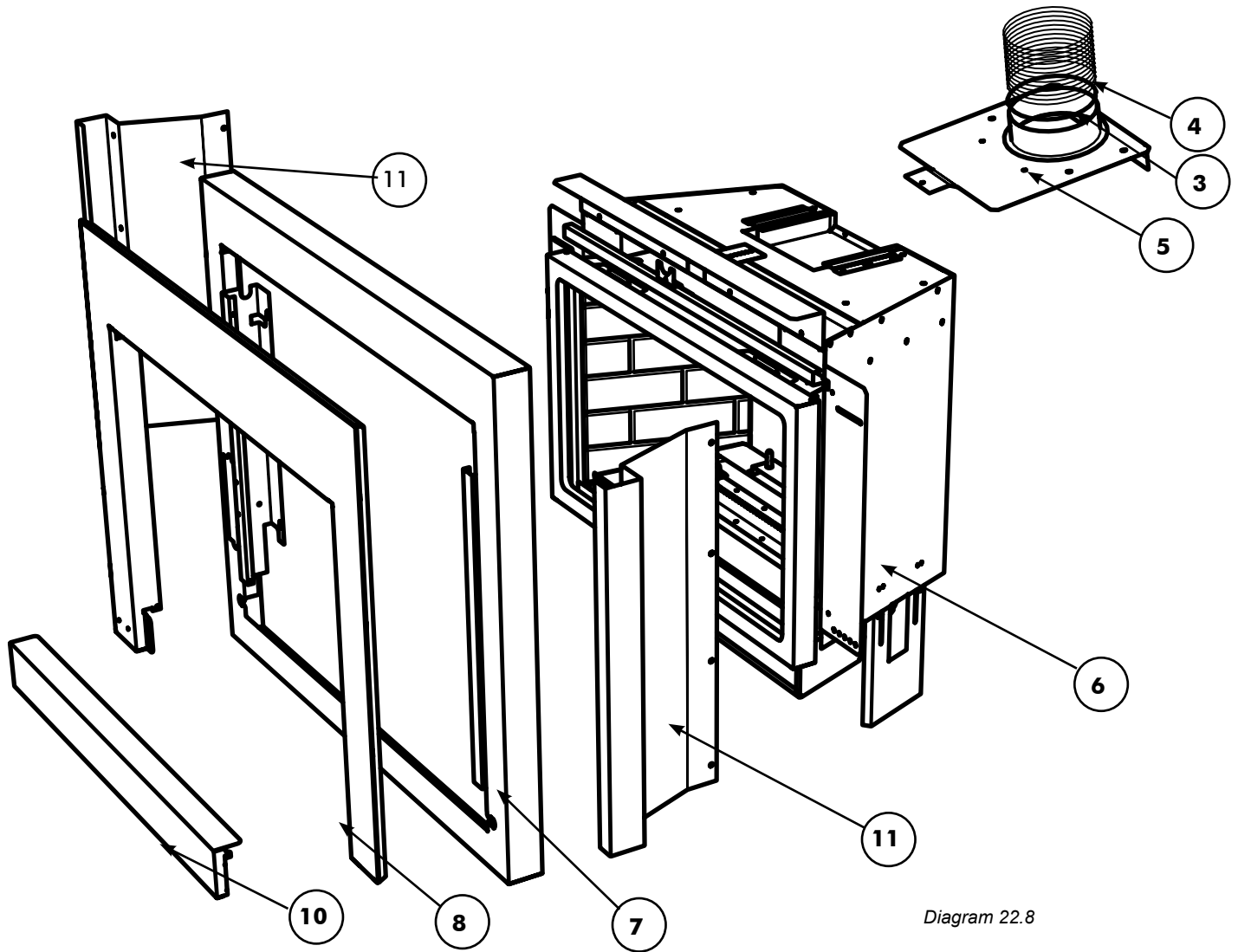

Diagram 22.8

Item	Part #	Description	Item	Part #	Description
			8		Faceplate panel Front
3		Ring Clamp	9		Magnet Bracket (not shown)
4		Flex section	10		Control Cover
5		Adaptor Slide Plate	11		Firesong 120N Firebox supports
6		E18E Chassis			
7		Faceplate Panel Rear			

## Indoor Gas Product Warranty

### Limited Lifetime Warranty

FPI Fireplace Products International Ltd. (for Canadian customers) and Fireplace Products US, Inc. (for US customers) (collectively referred to herein as “FPI”) extends this Limited Lifetime Warranty to the original purchaser of this Appliance provided the product remains in the original place of installation. The items covered by this Limited Lifetime Warranty and the period of such coverage are set forth in the table below.

An Appliance in this policy is defined as an Indoor Gas Fireplace, Indoor Gas Insert, Indoor Gas Freestanding Stove.

**This Appliance has only been certified and listed for use indoors.**

This Limited Lifetime Warranty starts on the day the Appliance was purchased.

**The Limited Lifetime Warranty is not transferable, amendable or negotiable under any circumstances.**

Indoor Gas Products Warranty Coverage Parts and Labor	Limited Lifetime	5 years	2 years	1 year	Subsidized Labor Coverage* (Years)
Firebox and Heat Exchanger	✓				3
Steel Burner Tube	✓				3
Glass Thermal breakage only	✓				3
All painted Surrounds/Inlays Finishes		✓			3
Brick Panels/Log sets/Ceramic Burners		✓			3
All Castings		✓			3
Valve assembly and all gas control components (Pilot assembly, flame sensors, Spark Electrode, Pilot Tubing, Orifices, Thermocouple, Thermopile)			✓		2
All Other Electrical components (Ignition Control Boards, Wiring, Switches, Blowers, Blower Control Module, Battery Pack, Remote Control Systems)			✓		2
Enamel Panels			✓		1
Venting/Venting Components			✓		1
All Stainless steel surrounds All black chrome Brushed nickel/Antique copper Faceplates/surrounds All Inner/Outer Black Glass panels				✓	1
All Firebox Media (Crystals, Fire beads, Volcanic, Ceramic, Spa Stones, River Pebbles)				✓	1
All hardware				✓	1
WIFI Dongle				✓	1
Mesh/Glass Safety Barriers				✓	1
Accent Light Bulbs				✓	1
Glass (Crazing)				✓	1

**Note:** Warranty coverage noted above may not be applicable as components/options vary based on appliance purchased.

### Conditions:

Warranty protects against defect in manufacture or FPI factory-assembled components only, unless herein specified otherwise.

**\*This warranty does not cover dealer travel costs, mileage, fuel, tolls for diagnostic or service work. All labor rates paid to authorized dealers are subsidized, pre-determined rates. Dealers may charge you for travel and additional**



Any part(s) found to be defective during the warranty period as outlined above will be repaired or replaced at FPI's option through an accredited distributor, dealer or pre-approved and assigned agent; provided that the defective part is returned to the distributor, dealer or agent for inspection if requested by FPI. Alternatively, FPI may, at its discretion, fully discharge all of its obligations under warranty by refunding the verified purchase price of the product to the original purchaser. The purchase price must be confirmed by the original Bill of Sale. **The authorized selling dealer, or an alternative authorized FPI dealer if pre-approved by FPI, is responsible for all in-field diagnosis and service work related to all warranty claims. FPI is not responsible for results or costs of workmanship of unauthorized FPI dealers or agents in the negligence of their service work.**

At all times, FPI reserves the right to inspect reported in the field/on location complaints of products claimed to be defective before processing or authorizing any claim. Failure to allow this upon request will void the warranty.

All warranty claims must be submitted by the dealer servicing the claim, including a copy of the Bill of Sale (proof of purchase by you). All claims must be complete and provide full details as requested by FPI to receive consideration for evaluation. **Incomplete claims may be rejected.**

**Replacement Appliances to the original purchaser are limited to one per warranty term.** Appliances must be installed according to all manufacturers' instructions as per the manual. All Local and National required codes must be met.

The installer is responsible for ensuring the Appliance is operating as designed at the time of installation.

The original purchaser is responsible for the annual maintenance of the Appliance, as outlined in the owner's manual. As outlined below, the warranty may be voided due to problems caused by a lack of maintenance.

Purchased parts: Repair/replacement parts purchased by the consumer from FPI after the original coverage has expired on the Appliance will carry a **90-day** warranty from the purchase date, valid with a receipt only. Any item shown to be defective will be repaired or replaced at our discretion. No labor coverage is included with these parts.

Special Finishes - One year on brushed nickel, black chrome and antique copper faceplates/surrounds. You can expect some changes in color as the product "ages" with constant heating and cooling. FPI warranties the product for any manufacturing defects on the original product. However, the manufacturer's warranty does not cover changing colors and marks, i.e. fingerprints, etc. applied after the purchase of the product. Damage from the use of abrasive cleaners is not covered by warranty.

If freight damage has been found either externally or internally, the dealer must be informed within 3 days. All claims as a result of damage must be submitted by the dealer servicing the claim, including a copy of the Bill of Sale (proof of purchase). All claims must be complete and provide full details as requested by FPI to receive consideration for evaluation. **Incomplete claims may be rejected.**

As this is a Limited Lifetime Warranty, if the Appliance needs to be replaced, the Appliance that was purchased at the time of sale might not be replaced with exactly the same model Appliance. In that case, FPI will replace your Appliance with one that is similar at the time of replacement under the terms of this Limited Lifetime Warranty, but **ONLY** in the event that an item covered by the Limited Lifetime Warranty is found to be defective. Please refer to the table on first page of this warranty for items covered by the Limited Lifetime Warranty. Product changes might be the result of the original Appliance being discontinued, changes in regulatory requirements, product advancements, etc., which are beyond the control of FPI. **This Limited Lifetime Warranty does not cover any installation costs, or costs associated with changes of required clearances for the replacement Appliance, hearth pads, mantles, facing and/or facing materials such as framing, completed walls made of drywall, wood, non-combustible board, tile, brick, stone, marble etc., venting/chimney systems, or components of the chimney system.**

If a suitable replacement is not available, FPI will refund **50%** of the purchase price of the Appliance and any applicable FPI accessories (faceplates, brick panels, media, etc.) purchased at the time of sale. **In no event will FPI refund any portion of the purchase price of, or reimburse costs associated with, any other items, including without limitation, installation of a new Appliance, changes of required clearances for a new Appliance, hearth pads, mantles, facing and/or facing materials such as framing, completed walls made of drywall, wood, non-combustible board, tile, brick, stone, marble etc., venting/chimney systems, or components of the chimney system. A copy of the receipt or bill of sale will be necessary to validate the purchase price.**

# warranty

## **Exclusions:**

This Limited Lifetime Warranty does not extend to paint, rust or corrosion of any kind due to a lack of maintenance or improper venting, combustion air provision, corrosive chemicals (i.e. chlorine, salt, air, etc.), door or glass gasketing, batteries, color fading, carbon/sooting of the log sets due to use and does not cover lava rock, platinum/glowing embers, vermiculite.

Malfunction, damage or performance-based issues as a result of environmental conditions, location, chemical damages, downdrafts, installation error, an installation by an unqualified installer, incorrect chimney components (including but not limited to cap size or type), operator error, abuse, misuse, use of improper fuels, lack of regular maintenance and upkeep, acts of God, weather-related problems from hurricanes, tornados, earthquakes, floods, lightning strikes/bolts or acts of terrorism or war, which result in a malfunction of the Appliance are not covered under the terms of this Limited Lifetime Warranty.

FPI has no obligation to enhance or modify any Appliance once manufactured (i.e. as products evolve, field modifications or upgrades will not be performed on existing Appliances).

Any Appliance showing signs of neglect or misuse will not be covered under the terms of this warranty policy and may void this warranty, including Appliances with rusted or corroded fireboxes that have not been reported as rusted or corroded within **three (3)** months of installation/purchase.

Appliances which show evidence of being operated while damaged, or with problems known to the purchaser and causing further damages will void this warranty.

Appliances where the serial no. has been altered, deleted, removed or made illegible will void this warranty.

Minor movement, expansion and contraction of the steel is normal and is not covered under the terms of this warranty.

Freight damages for products or parts are not covered under the terms of the warranty.

Products made or provided by other manufacturers and used in conjunction with the FPI Appliance without prior authorization from FPI may void this warranty.

## **Limitations of Liability:**

The original purchaser's exclusive remedy under this warranty, and FPI's sole obligation under this Limited Lifetime Warranty, express or implied, in contract or in tort, shall be limited to replacement, repair, or refund, as outlined above. IN NO EVENT WILL FPI BE LIABLE UNDER THIS WARRANTY FOR ANY INCIDENTAL OR CONSEQUENTIAL COMMERCIAL DAMAGES OR DAMAGES TO PROPERTY. TO THE EXTENT PERMITTED BY APPLICABLE LAW, FPI MAKES NO EXPRESS WARRANTIES OTHER THAN THE WARRANTY SPECIFIED HEREIN. THE DURATION OF ANY IMPLIED WARRANTY IS LIMITED TO DURATION OF THE EXPRESSED WARRANTY SPECIFIED ABOVE. IF IMPLIED WARRANTIES CANNOT BE DISCLAIMED, THEN SUCH WARRANTIES ARE LIMITED IN DURATION TO THE DURATION OF THIS WARRANTY.

Some US states do not allow limitations on how long an implied warranty lasts, or allow exclusion or limitation of incidental or consequential damages, so the above limitations or exclusions may not apply to you.

Customers located outside the US should consult their local, provincial or national legal codes for additional terms, which may apply to this warranty.

**How to Obtain Warranty Service:**

Customers should contact the authorized selling dealer to obtain warranty service. In the event the authorized selling dealer is unable to provide warranty service, please contact FPI by mail at the address listed below. Please include a brief description of the problem and your address, email and telephone contact information. A representative will contact you to make arrangements for an inspection and/or warranty service.

Canadian Warrantor:

**FPI Fireplace Products International Ltd.**

6988 Venture St.  
Delta, British Columbia  
Canada, V4G 1H4

U.S. Warrantor:

**Fireplace Products US, Inc.**

PO Box 2189 PMB 125  
Blaine, WA  
United States, 98231

Or contact the Regency Customer Care Centre at 1-800-442-7432 (phone) / 604-946-4349 (fax)  
/customerservice@regency-fire.com (e-mail)

**Product Registration and Customer Support:**

Thank you for choosing a Regency Fireplace. Regency strives to be a world leader in the design, manufacture, and marketing of hearth products. To provide the best support for your product, we request that you complete a product registration form at <http://www.regency-fire.com/Customer-Care/Warranty-Registration.aspx> within **ninety (90)** days of purchase.



**Product Registration and Customer Support:**

Thank you for choosing a Regency Fireplace. Regency strives to be a world leader in the design, manufacture, and marketing of hearth products. To provide the best support for your product, we request that you complete a product registration form found on our Web Site under Customer Care within ninety (90) days of purchase.

For purchases made in **CANADA or the UNITED STATES:**

<http://www.regency-fire.com/Customer-Care/Warranty-Registration.aspx>

For purchases made in **AUSTRALIA:**

<http://www.regency-fire.com.au/Customer-Care/Warranty-Registration.aspx>

You may also complete the warranty registration form below to register your Regency Fireplace Product and mail and/or fax it back to us, and we will register the warranty for you. It is important you provide us with all the information below in order for us to serve you better.

**Warranty Registration Form (or Register online immediately at the above Web Site):**

<b>Warranty Details</b>	
Serial Number (required):	
Purchase Date (required) (mm/dd/yyyy):	
<b>Product Details</b>	
Product Model (required):	
<b>Dealer Details</b>	
Dealer Name (required):	
Dealer Address:	
Dealer Phone #:	
Installer:	
Date Installed (mm/dd/yyyy):	
<b>Your Contact Details (required)</b>	
Name:	
Address:	
Phone:	
Email:	

For purchases made in **CANADA:**

**FPI Fireplace Products International Ltd.**  
6988 Venture St.  
Delta, British Columbia  
Canada, V4G 1H4

Phone: 604-946-5155  
Fax: 1-866-393-2806

For purchases made in the **UNITED STATES:**

**Fireplace Products US, Inc.**  
PO Box 2189 PMB 125  
Blaine, WA  
United States, 98231

Phone: 604-946-5155  
Fax: 1-866-393-2806

For purchases made in **AUSTRALIA:**

**Fireplace Products Australia Pty Ltd**  
99 Colemans Road  
Dandenong South, Vic. 3175  
Australia

Phone: +61 3 9799 7277  
Fax: +61 3 9799 7822

For fireplace care and tips and answers to most common questions please visit our Customer Care section on our Web Site. Please feel free to contact your selling dealer if you have any questions about your Regency product.



# recycling

**PRODUCT LIFE CYCLE:**

By recycling your used appliances, you divert waste from your local landfills and help the environment. You also reduce the need for raw materials to manufacture new products. Contact your local municipality for appliance recycling services, local recycling programs, or appliance removal services to ensure your Regency appliance components, and packaging are properly recycled.



***Installer: Please complete the following information***

**Dealer Name & Address:** \_\_\_\_\_

\_\_\_\_\_

**Installer:** \_\_\_\_\_

**Phone #:** \_\_\_\_\_

**Date Installed:** \_\_\_\_\_

**Serial #:** \_\_\_\_\_