



Liberty® LRI4E / Regency Horizon® HRI4E Gas Insert

Owners & Installation Manual



Liberty® LRI4E



Horizon® HRI4E

www.regency-fire.com

MODELS: LRI4E-NG11 Natural Gas
HRI4E-NG11 Natural Gas

LRI4E-LP11 Propane
HRI4E-LP11 Propane

⚠ WARNING
FIRE OR EXPLOSION HAZARD
Failure to follow safety warnings exactly could result in serious injury, death, or property damage.

- Do not store or use gasoline or other flammable vapors and liquids in the vicinity of this or any other appliance.
- **WHAT TO DO IF YOU SMELL GAS**
 - Do not try to light any appliance.
 - Do not touch any electrical switch: do not use any phone in your building. Leave the building immediately.
 - Immediately call your gas supplier from a neighbour's phone. Follow the gas supplier's instructions.
 - If you cannot reach your gas supplier, call the fire department.
- Installation and service must be performed by a qualified installer, service agency or the gas supplier.



Certified to/Certifié pour: CSA 2.17-2017
ANSI Z21.88-2019
CSA 2.33-2019

Installer: Please complete the details on the back cover and leave this manual with the homeowner.
Homeowner: Please keep these instructions for future reference.

TO THE NEW OWNER

Congratulations! You are the owner of a state-of-the-art Gas Insert by Regency.

The Regency Gas Insert Series of hand crafted appliances has been designed to provide you with all the warmth and charm of a fireplace, at the flick of a switch. The models LRI4E / HRI4E of this series have been approved by Intertek for both safety and efficiency as it also bears our own mark, it promises to provide you with economy, comfort and security for many trouble free years to follow.

Please take a moment now to acquaint yourself with these instructions and the many features of your Regency Fireplace.



DANGER

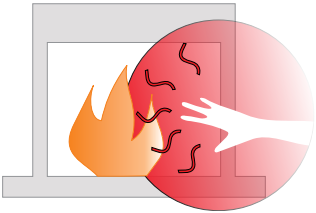

**HOT GLASS WILL
CAUSE BURNS**

**DO NOT TOUCH GLASS
UNTIL COOLED**

**NEVER ALLOW CHILDREN
TO TOUCH GLASS**

A barrier designed to reduce the risk of burns from the hot viewing glass is provided with this appliance and must be installed for the protection of children and other at risk individuals.

CAUTION:
HOT WHILE IN OPERATION. DO NOT TOUCH.
SEVERE BURNS MAY RESULT. KEEP CHILDREN, CLOTHING, FURNITURE,
GASOLINE, AND ANY OTHER LIQUIDS WITH FLAMMABLE VAPOURS AWAY.

KEEP BURNER AND CONTROL COMPARTMENT CLEAN.
SEE INSTALLATION AND OPERATING INSTRUCTIONS ACCOMPANYING
APPLIANCE.

920-408



*Liberty Gas
Inserts Benefits*



*Horizon Gas
Inserts Benefits*



Horizon HRI4E



Liberty LRI4E

ON DEMAND PILOT LIGHT (SEVEN DAY SAFETY TIMER)

Important information if using the appliance in CPI (continuous pilot mode) only.

This appliance is a ProFlame 1 system fitted with the "On Demand" Pilot, a safety feature which will shut down the gas valve completely by extinguishing the pilot light in the event of a continuous full seven days of inactivity.

This only applies if the CPI (continuous pilot) switch is in the "on" position.

Each time the main burner shuts down, manually or through the call from the thermostat, the seven day timer starts again.

The seven day inactivity timer is controlled within the circuit board. Therefore, if in CPI mode and when the pilot light is extinguished after seven straight days of inactivity, the IPI/CPI rocker switch will remain in the "on" position. Therefore, all that is required to relight the pilot would be to press the on/off button on the remote control transmitter from "on" to "off" and back to "on". Once the pilot has re-established operation will resume as normal. There is no requirement to do anything with the IPI/CPI rocker switch.

If the unit never goes as long as seven full days without a call for heat, the pilot will remain lit until it is manually shut-off.

If the unit is being operated in IPI (intermittent pilot) mode, neither the above instructions nor the seven day timer will apply.

See the instructions in this manual and on the Lighting Instructions plate on the appliance to light or re-light the pilot.

OWNER'S INFORMATION

On Demand Pilot Light (seven day safety timer)2
 Copy of Safety Decals.....9-10
 MA Code - CO Detector.....11
 Important Message14
 Before You Start.....14
 For Your Safety14
 Specifications.....14
 Lighting Procedure15
 Shutdown Procedure15
 Copy of Lighting Plate Instructions16
 Proflame I remote control operating instructions.....17

Warranty68



INSTALLER'S INFORMATION

Unit dimensions with Vignette faceplate.....4
 Unit dimensions with Vignette faceplate + small backing plate4
 Unit dimensions with Vignette faceplate + small backing plate + spacer5
 Unit dimensions with 4 sided Vignette faceplate + backing plate6
 Unit dimensions w/ arched Vignette faceplate (optional)7
 Unit dimensions with arched Vignette faceplate + backing plate.....7
 Unit dimensions w/arched Vignette faceplate + Spacer 8
 Unit dimensions with arched Vignette faceplate + spacer + backing plate.....8
 Gas Installation Checklist12
 Remote Receiver Battery Replacement.....20
 Gas Pressure Testing21
 Installation Into A Solid Fuel Burning Fireplace Or Factory Built Fireplace.....21
 Factory-Built (Metal) Wood-Burning Fireplace Requirements.....21
 Installation Checklist.....22
 Materials Required.....22
 Minimum Fireplace Dimensions.....22
 Minimum Clearances to combustibles.....23
 Gas Connection.....24
 Venting.....24

Flue / Vent Installation25
 Levelling Leg Adjustment.....26
 Air Shutter Adjustment27
 System Data28
 High Elevation.....28
 Gas Line Installation28
 Gas Pipe Pressure Testing28
 885 S.I.T. Valve Description.....28
 Proflame Remote System GTMF with Fan29
 Optional Wall Thermostat Installation30
 Conversion from NG to LP31
 Media Installation.....33
 HRI4E Optional Log Set Installation35
 LRI4E Log Set Installation38
 Standing Pilot & Heat Exchange Return/Flue Restrictor.....40
 Brick Panel Installation41
 Enamel/Steel Panel Installation42
 Glass Door Removal / Installation43
 Vignette Faceplate with Safety Screen Installation44
 Inlay Installation45
 4 Sided Faceplate with Safety Screen Installation.....46
 Spacer Installation.....47
 Backing Plate Installation48
 Optional Arched Vignette Faceplate Installation49
 Optional Backing Plate Installation.....50
 Optional Mantel Deflector Installation - Vignette51
 Optional Hearth Trim Installation52
 Operating Instructions54
 On Demand Pilot Light54
 First Fire.....54
 Automatic Convection Fan Operation54
 Normal Operating Sounds Of Gas Appliances.....55
 Copy Of Lighting Instruction Plate55
 Maintenance Instructions56
 Door Glass56
 Pilot Adjustment.....57
 General Vent Maintenance57
 Log Replacement57
 Glass Gasket.....57
 Glass Crystal Burner Removal / Installation - HRI4E...58
 Glass Burner Removal.....58
 Glass Burner Install58
 LRI4E Ceramic Burner Removal / Installation.....59
 Fan Maintenance - with GTMF Remote Control60
 Valve Replacement.....61
 Gas Maintenance.....62
 Main Assembly.....64
 Vignette Faceplate.....65
 Arched Vignette Faceplate.....67

Warranty68

Recycling74

NATIONAL FIREPLACE INSTITUTE

 We recommend that our products be installed and serviced by professionals who are certified in the U.S. by the National Fireplace Institute® (NFI) or in Canada by Wood Energy Technical Training (WETT).

 CERTIFIED
 www.nficertified.org

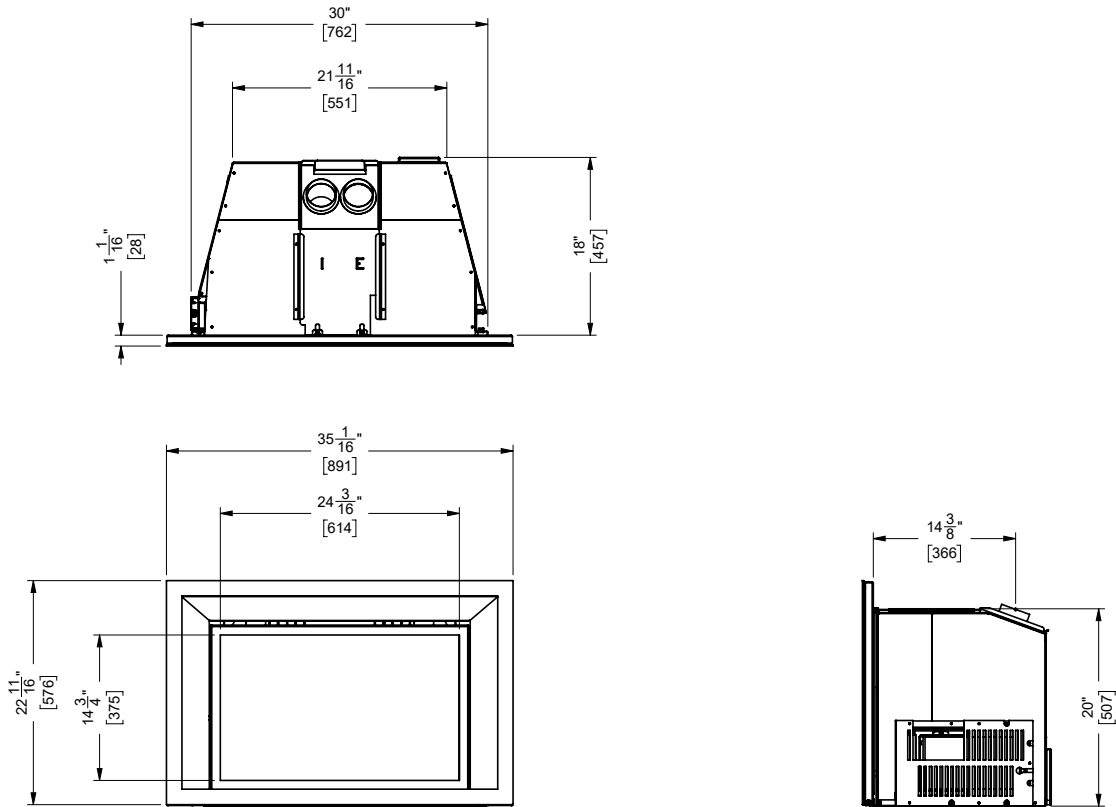
dimensions

UNIT DIMENSIONS WITH VIGNETTE FACEPLATE

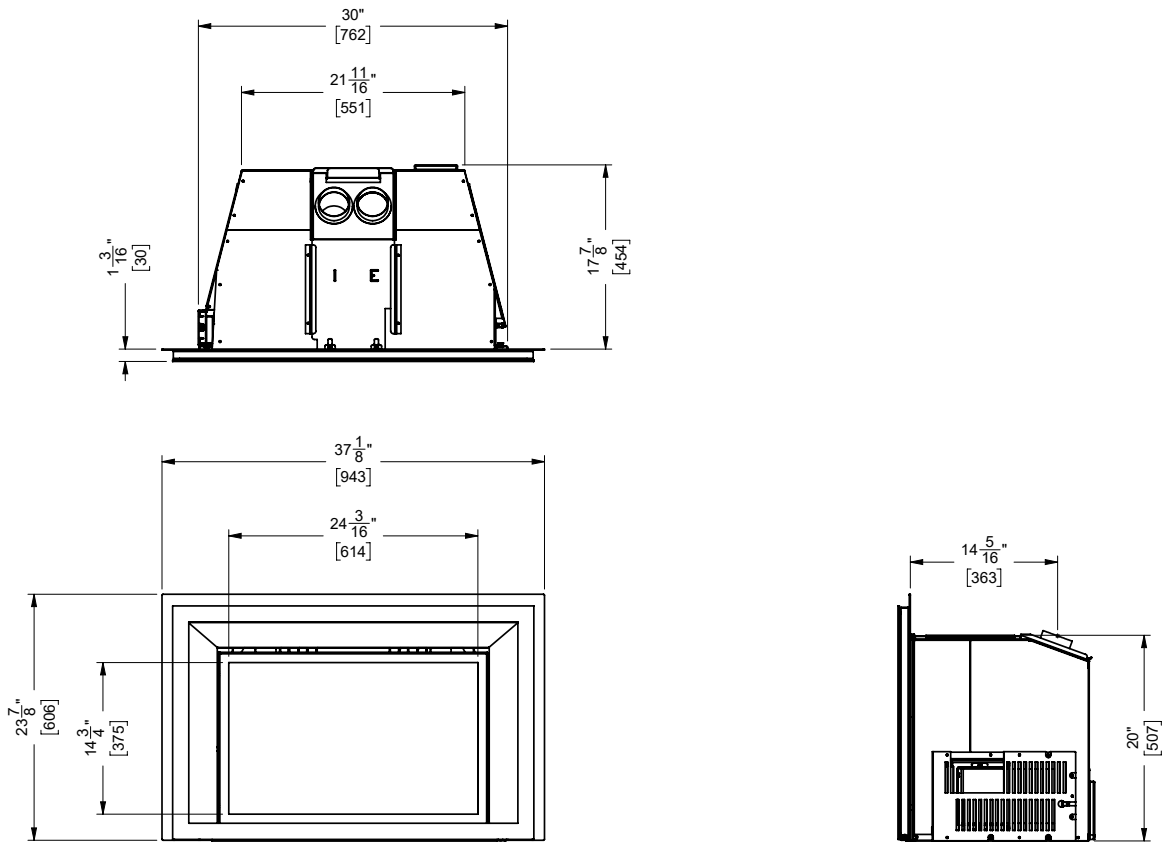

UNIT DIMENSIONS WITH VIGNETTE FACEPLATE + SMALL BACKING PLATE



UNIT DIMENSIONS WITH VIGNETTE FACEPLATE + SMALL BACKING PLATE + SPACER

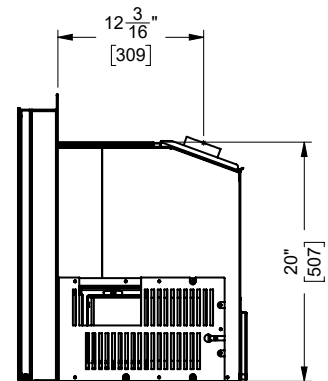
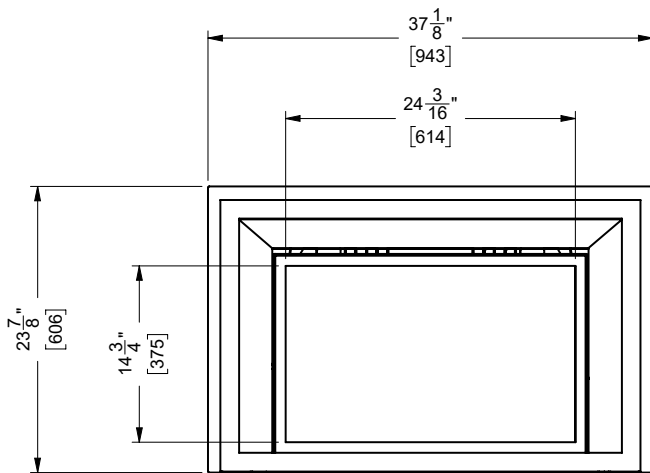
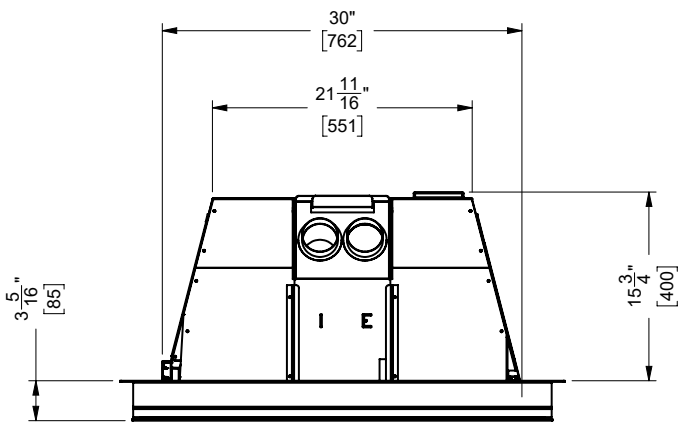

Not shown:
Regular backing plate - 41 5/8" W. x 26" H.
Oversize backing plate - 44" W. x 30" H.

**ALL PICTURES / DIAGRAMS SHOWN THROUGHOUT THIS MANUAL ARE FOR ILLUSTRATION PURPOSES ONLY.
ACTUAL PRODUCT MAY VARY DUE TO PRODUCT ENHANCEMENTS.**

dimensions

UNIT DIMENSIONS WITH 4 SIDED VIGNETTE FACEPLATE + BACKING PLATE

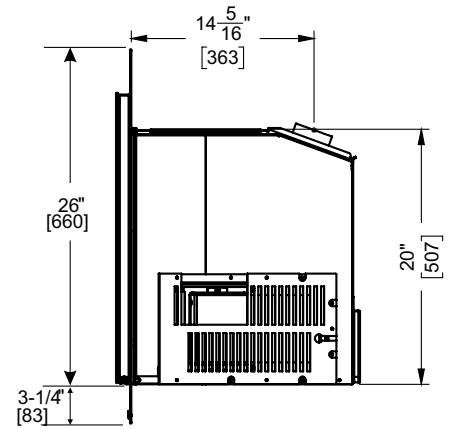
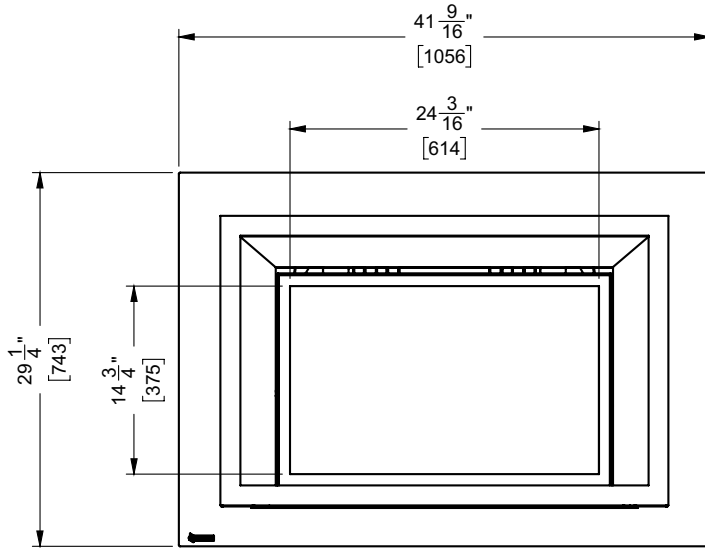
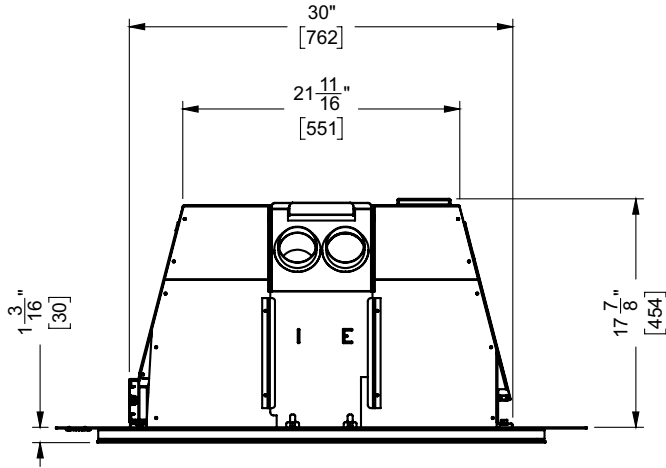

UNIT DIMENSIONS WITH ARCHED VIGNETTE FACEPLATE (OPTIONAL)

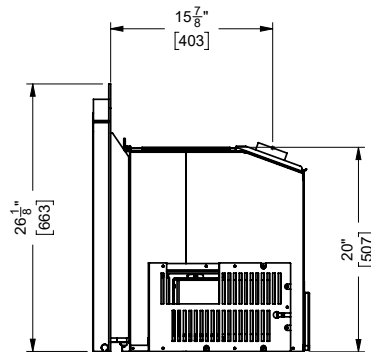
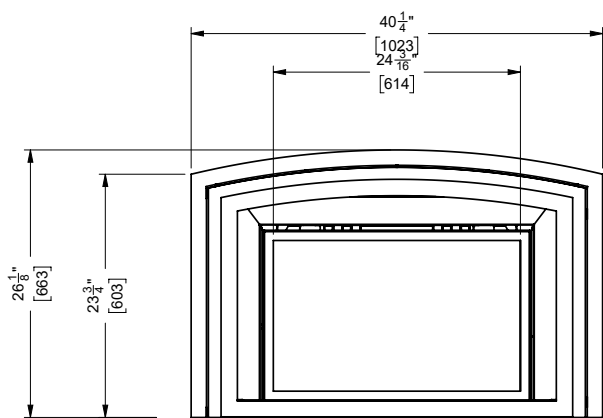
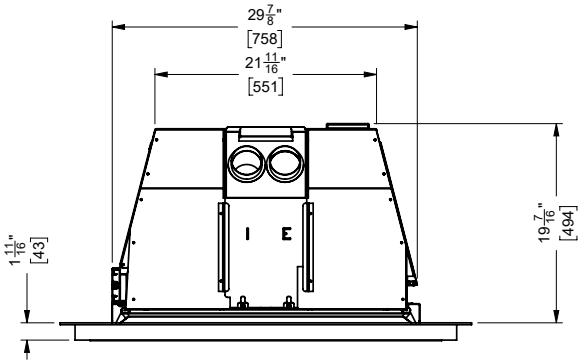

UNIT DIMENSIONS WITH ARCHED VIGNETTE FACEPLATE + BACKING PLATE

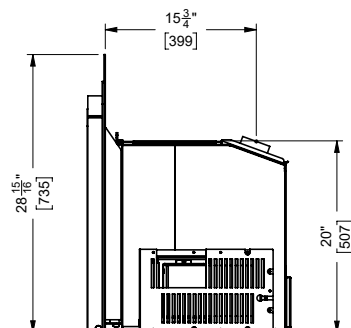
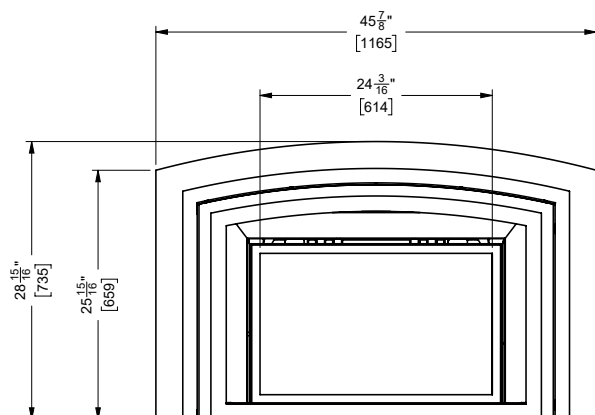
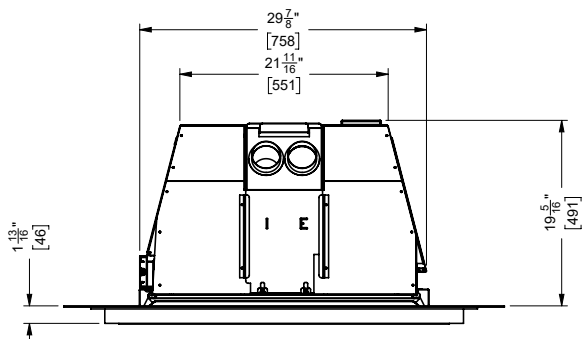

dimensions

UNIT DIMENSIONS WITH ARCHED VIGNETTE FACEPLATE + SPACER

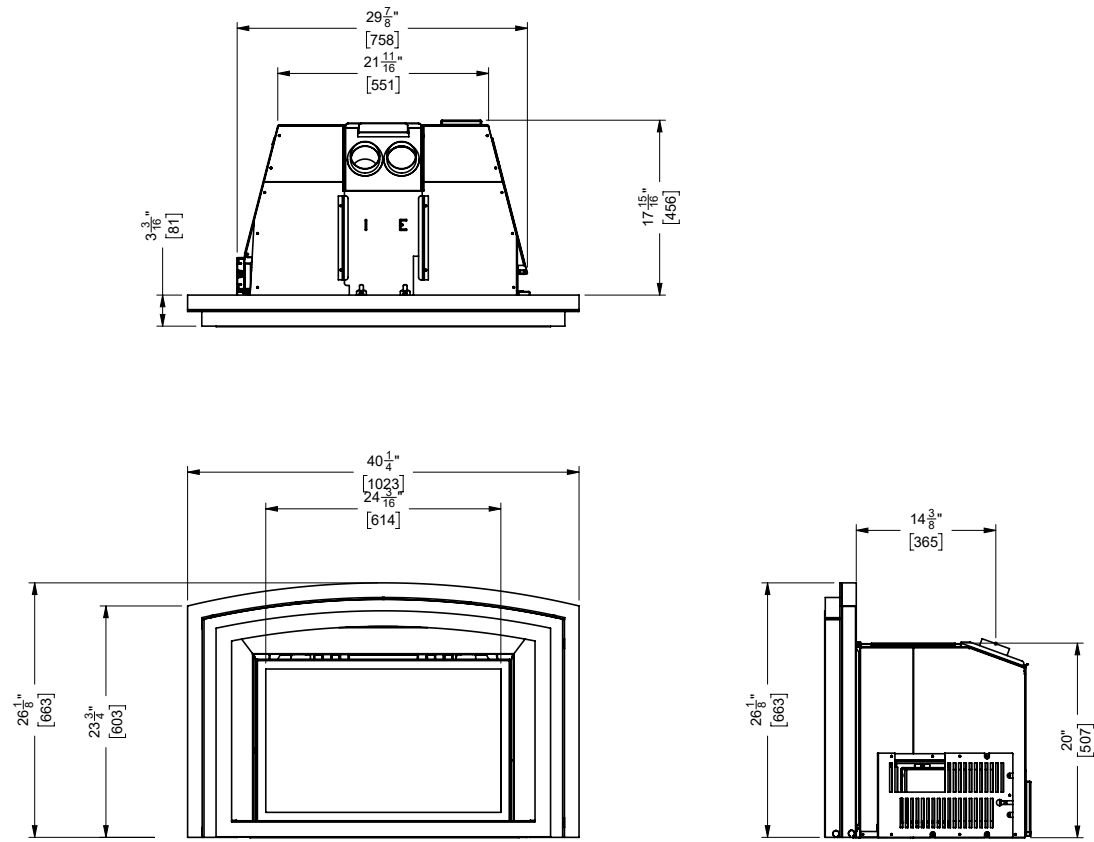

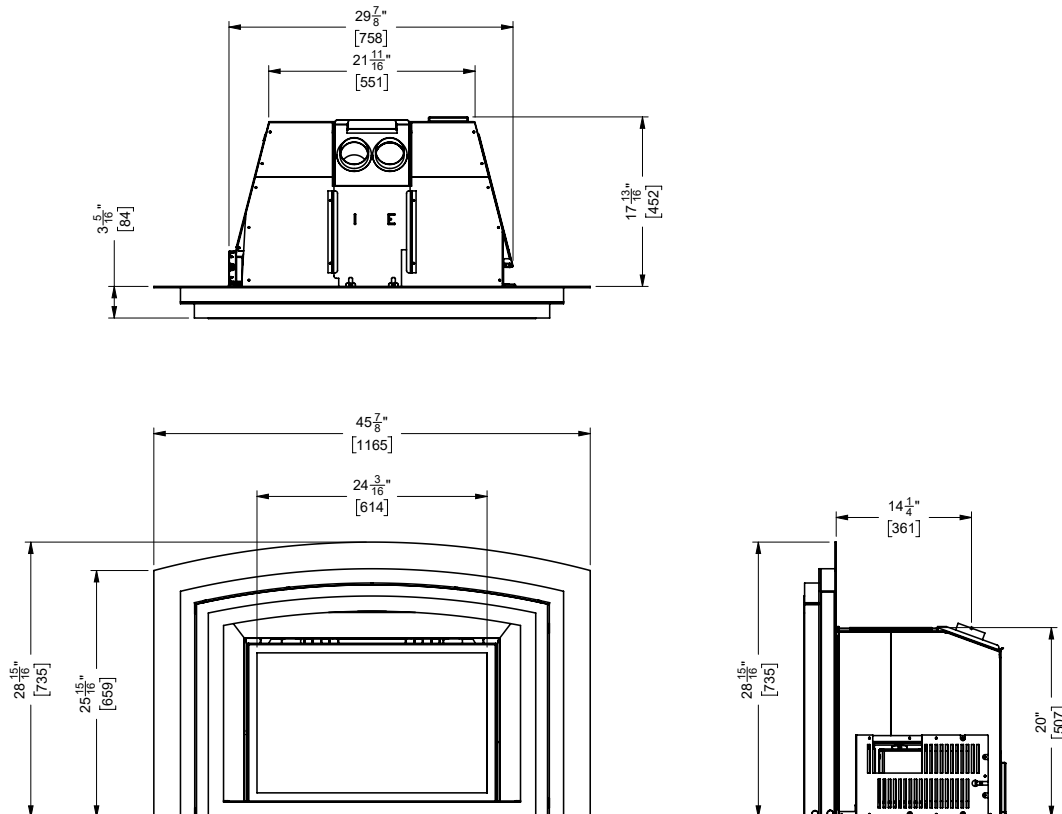

UNIT DIMENSIONS WITH ARCHED VIGNETTE FACEPLATE + SPACER + BACKING PLATE



COPY OF SAFETY LABEL

This is a copy of the labels that accompany each LRI4E Gas Insert. We have printed a copy of the contents here for your review.

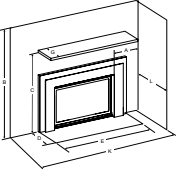
NOTE: Regency units are constantly being improved. Check the label on the unit and if there is a difference, the label on the unit is the correct one.

Duplicate Serial number/Copie No de série		481																													
 Listed/Nom: VENTED GAS FIREPLACE HEATER / FOYER AU GAZ VENTILÉ Certified to / Certifié : ANSI Z21.88:2019 • CSA-2.33:2019 CSA 2.17-2017 MAY BE INSTALLED IN MANUFACTURED (MOBILE) HOMES AFTER FIRST SALE. Refer to Intertek's Directory of Building Products for detailed information. Pour plus de détails, se reporter au Répertoire des produits de construction de Intertek.		DO NOT REMOVE THIS LABEL / NE PAS ENLEVER CETTE ÉTIQUETTE 481 Serial No. / No de série																													
Modèles/modèles LRI4E-NG11	NATURAL GAS FIREPLACE INSERT: MODÈLE LRI4E-NG11 Factory Equipped For Altitude 0-4500ft. (0-1370m)	MODÈLE LRI4E-NG11 FUNCTIONNANT AU GAZ NATUREL																													
	<table border="0"> <tr> <td>Min. supply pressure</td> <td>5"</td> <td>WC</td> <td>(1.25 kpa)</td> <td>Pression d'alimentation minimale</td> </tr> <tr> <td>Low Setting Man. pressure</td> <td>1.6"</td> <td>WC</td> <td>(0.41 kpa)</td> <td>Pression de sortie (manifold) - basse</td> </tr> <tr> <td>Max. Manifold pressure</td> <td>3.5"</td> <td>WC</td> <td>(0.87 kpa)</td> <td>Pression de sortie (manifold) - max.</td> </tr> <tr> <td>Orifice size</td> <td>#37</td> <td>DMS</td> <td></td> <td>Taille de l'orifice</td> </tr> <tr> <td>Minimum input</td> <td>22,000</td> <td>Btu/h</td> <td>(6.45 kW)</td> <td>Débit calorifique minimal</td> </tr> <tr> <td>Maximum input</td> <td>31,000</td> <td>Btu/h</td> <td>(9.09 kW)</td> <td>Débit calorifique maximal</td> </tr> </table>	Min. supply pressure	5"	WC	(1.25 kpa)	Pression d'alimentation minimale	Low Setting Man. pressure	1.6"	WC	(0.41 kpa)	Pression de sortie (manifold) - basse	Max. Manifold pressure	3.5"	WC	(0.87 kpa)	Pression de sortie (manifold) - max.	Orifice size	#37	DMS		Taille de l'orifice	Minimum input	22,000	Btu/h	(6.45 kW)	Débit calorifique minimal	Maximum input	31,000	Btu/h	(9.09 kW)	Débit calorifique maximal
Min. supply pressure	5"	WC	(1.25 kpa)	Pression d'alimentation minimale																											
Low Setting Man. pressure	1.6"	WC	(0.41 kpa)	Pression de sortie (manifold) - basse																											
Max. Manifold pressure	3.5"	WC	(0.87 kpa)	Pression de sortie (manifold) - max.																											
Orifice size	#37	DMS		Taille de l'orifice																											
Minimum input	22,000	Btu/h	(6.45 kW)	Débit calorifique minimal																											
Maximum input	31,000	Btu/h	(9.09 kW)	Débit calorifique maximal																											
Modèles/modèles LRI4E-LP11	PROPANE GAS FIREPLACE INSERT: MODÈLE LRI4E-LP11 Factory Equipped For Altitude 0-4500ft. (0-1370m)	MODÈLE LRI4E-LP11 FUNCTIONNANT AU GAZ PROPANE																													
	<table border="0"> <tr> <td>Min. supply pressure</td> <td>11"</td> <td>WC</td> <td>(2.73 kpa)</td> <td>Pression d'alimentation minimale</td> </tr> <tr> <td>Low Setting Man. pressure</td> <td>6.4"</td> <td>WC</td> <td>(1.59 kpa)</td> <td>Pression de sortie (manifold) - basse</td> </tr> <tr> <td>Max. Manifold pressure</td> <td>10"</td> <td>WC</td> <td>(2.48 kpa)</td> <td>Pression de sortie (manifold) - max.</td> </tr> <tr> <td>Orifice size</td> <td>#53</td> <td>DMS</td> <td></td> <td>Taille de l'orifice</td> </tr> <tr> <td>Minimum input</td> <td>26,000</td> <td>Btu/h</td> <td>(7.62 kW)</td> <td>Débit calorifique minimal</td> </tr> <tr> <td>Maximum input</td> <td>31,000</td> <td>Btu/h</td> <td>(9.09 kW)</td> <td>Débit calorifique maximal</td> </tr> </table>	Min. supply pressure	11"	WC	(2.73 kpa)	Pression d'alimentation minimale	Low Setting Man. pressure	6.4"	WC	(1.59 kpa)	Pression de sortie (manifold) - basse	Max. Manifold pressure	10"	WC	(2.48 kpa)	Pression de sortie (manifold) - max.	Orifice size	#53	DMS		Taille de l'orifice	Minimum input	26,000	Btu/h	(7.62 kW)	Débit calorifique minimal	Maximum input	31,000	Btu/h	(9.09 kW)	Débit calorifique maximal
Min. supply pressure	11"	WC	(2.73 kpa)	Pression d'alimentation minimale																											
Low Setting Man. pressure	6.4"	WC	(1.59 kpa)	Pression de sortie (manifold) - basse																											
Max. Manifold pressure	10"	WC	(2.48 kpa)	Pression de sortie (manifold) - max.																											
Orifice size	#53	DMS		Taille de l'orifice																											
Minimum input	26,000	Btu/h	(7.62 kW)	Débit calorifique minimal																											
Maximum input	31,000	Btu/h	(9.09 kW)	Débit calorifique maximal																											
Minimum Clearances to Combustibles from Insert/Dégagements min. combustibles <table border="0"> <tr> <td>Side wall / mur latéral</td> <td>A</td> <td>8"</td> <td>(203mm)</td> </tr> <tr> <td>Ceiling / Plafond</td> <td>B</td> <td>60"</td> <td>(1524mm)</td> </tr> <tr> <td>Mantel / Manteau</td> <td>C</td> <td>35"</td> <td>(889mm)</td> </tr> <tr> <td>Min. Alcove Width/ Largeur min. alcôve</td> <td>K</td> <td>54"</td> <td>(1372mm)</td> </tr> <tr> <td>Max. Alcove Depth/ Prof. max. alcôve</td> <td>L</td> <td>36"</td> <td>(914mm)</td> </tr> </table>		Side wall / mur latéral	A	8"	(203mm)	Ceiling / Plafond	B	60"	(1524mm)	Mantel / Manteau	C	35"	(889mm)	Min. Alcove Width/ Largeur min. alcôve	K	54"	(1372mm)	Max. Alcove Depth/ Prof. max. alcôve	L	36"	(914mm)										
Side wall / mur latéral	A	8"	(203mm)																												
Ceiling / Plafond	B	60"	(1524mm)																												
Mantel / Manteau	C	35"	(889mm)																												
Min. Alcove Width/ Largeur min. alcôve	K	54"	(1372mm)																												
Max. Alcove Depth/ Prof. max. alcôve	L	36"	(914mm)																												
		Mantel Clearances / Dégagements manteau <table border="0"> <tr> <td>Min. Hearth Width/ Largeur min.âtre</td> <td>D</td> <td>14"</td> <td>(356mm)</td> </tr> <tr> <td>Min. Hearth Length/ Longueur min.âtre</td> <td>E</td> <td>40"</td> <td>(1016mm)</td> </tr> <tr> <td>Max. Mantle Depth/ Prof. max. manteau</td> <td>G</td> <td>12"</td> <td>(305mm)</td> </tr> </table>	Min. Hearth Width/ Largeur min.âtre	D	14"	(356mm)	Min. Hearth Length/ Longueur min.âtre	E	40"	(1016mm)	Max. Mantle Depth/ Prof. max. manteau	G	12"	(305mm)																	
Min. Hearth Width/ Largeur min.âtre	D	14"	(356mm)																												
Min. Hearth Length/ Longueur min.âtre	E	40"	(1016mm)																												
Max. Mantle Depth/ Prof. max. manteau	G	12"	(305mm)																												
MADE IN CANADA / FABRIQUÉ AU CANADA FPI Fireplace Products International Ltd., Delta BC, CANADA																															
This appliance must be installed in accordance with local codes, if any; if none, follow the National Fuel Gas Code, ANSI Z223.1, or Natural Gas and Propane Installation Code, CSA B149.1. This appliance is only for use with the type of gas indicated on the rating plate. This appliance is not convertible for use with other gases unless a certified kit is used. This appliance is only for use with the type of gas indicated on the rating plate and may be installed in an aftermarket, permanently located, manufactured (mobile) home where not prohibited by local codes. See owner's manual for details. WARNING: This fireplace has been converted for use with a gas fireplace insert only and cannot be used for burning wood or solid fuels unless all original parts have been replaced, and the fireplace re-approved by the authority having jurisdiction. Cet appareil doit être installé conformément aux codes et règlements locaux, ou, en l'absence de tels règlements, conformément au National Fuel Gas Code ANSI Z223.1, ou au CSA-B149.1 en vigueur. Cet appareil doit être utilisé uniquement avec le type de gaz indiqué sur la plaque signalétique. Cet appareil n'est pas convertible pour être utilisé avec d'autres gaz, sauf si une trousse de conversion certifiée est utilisée. Cet appareil doit être utilisé uniquement avec le type de gaz indiqué sur la plaque signalétique et peut être installé dans une maison préfabriquée ou mobile (É.-U. seulement) installée à demeure si les règlements locaux le permettent. Voir le manuel d'utilisation pour plus de renseignements. Cet appareil ne peut pas être utilisé avec d'autres gaz sauf si une trousse de conversion certifiée est fournie. AVERTISSEMENT : Ce foyer a été converti pour être utilisé avec un foyer au gaz encastrable et ne peut être utilisé pour brûler du bois ou d'autres combustibles solides à moins que toutes les pièces d'origine aient été remises en place et que le foyer ait été homologué de nouveau par une autorité compétente. This vented gas fireplace heater is not for use with air filters. Ne pas utiliser de filtre à air avec ce foyer au gaz à évacuation. For use with glass doors certified with the appliance only. À utiliser uniquement avec les portes en verre certifiées avec l'appareil. For use only with barrier (Part # 399-100) Follow installation instructions. À utiliser uniquement avec l'écran de sécurité (Pièce n°399-100). Suivre les consignes d'installation. Electrical supply / Alimentation électrique 115VAC, 2.5 A, 60Hz, Less than 10A Fan Part # 911-071/Pièce ventilateur																															
VENTED GAS FIREPLACE HEATER - NOT FOR USE WITH SOLID FUELS. CATEGORY I. / FOYER AU GAZ À ÉVACUATION - NE PAS UTILISER AVEC UN COMBUSTIBLE SOLIDE. CATÉGORIE I.																															
 CANADIAN ENERGY PERFORMANCE VERIFIED / RENDÉMENT ÉNERGÉTIQUE VÉRIFIÉ Intertek EP5011189		CSA P.4.1 Fireplace Efficiency (FE) / Efficacité énergétique des foyers (EEF) CSA P.4.1 Natural Gas / Gaz naturel 70.27% Propane Gas / Gaz propane 69.36% 919-934c																													

For the State of Massachusetts, installation and repair must be done by a plumber or gas fitter licensed in the Commonwealth of Massachusetts.

For the State of Massachusetts, flexible connectors shall not exceed 36 inches in length.

For the State of Massachusetts, the appliances individual manual shut-off must be a t-handle type valve.

The State of Massachusetts requires the installation of a carbon monoxide alarm in accordance with NFPA 720 and a CO alarm with battery back up in the same room where the gas appliance is installed.

DECAL LOCATION



Remove faceplate from front of unit (see manual) Once the faceplate is removed the rating plate will be located below the glass (see picture).

DO NOT REMOVE THE DECAL FROM THE UNIT







safety decal

COPY OF SAFETY LABEL

This is a copy of the labels that accompany each HRI4E Gas Insert. We have printed a copy of the contents here for your review.

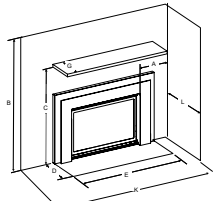
NOTE: Regency units are constantly being improved. Check the label on the unit and if there is a difference, the label on the unit is the correct one.

Duplicate Serial number		486																																			
 Intertek CH4001172	Listed/Nom: VENTED GAS FIREPLACE HEATER / FOYER AU GAZ VENTILÉ Certified to / Certifié : ANSI Z21.88:2019 • CSA-2.33:2019 CSA 2.17-2017 MAY BE INSTALLED IN MANUFACTURED (MOBILE) HOMES AFTER FIRST SALE. Refer to Intertek's Directory of Building Products for detailed information. Pour plus de détails, se reporter au Répertoire des produits de construction de Intertek.																																				
	486																																				
 HRI4E-NG11	NATURAL GAS FIREPLACE INSERT: MODEL HRI4E-NG11 Factory Equipped For Altitude 0-4500ft. (0-1370m)	MODELE HRI4E- NG11 FONCTIONNANT AU GAZ NATUREL																																			
	<table border="0" style="width: 100%;"> <tr> <td>Min. supply pressure</td> <td>5"</td> <td>WC</td> <td>(1.25 kpa)</td> </tr> <tr> <td>Low Setting Man. pressure</td> <td>1.6"</td> <td>WC</td> <td>(0.41 kpa)</td> </tr> <tr> <td>Max. Manifold pressure</td> <td>3.5"</td> <td>WC</td> <td>(0.87 kpa)</td> </tr> <tr> <td>Orifice size</td> <td>#37</td> <td>DMS</td> <td></td> </tr> <tr> <td>Minimum input</td> <td>22,000</td> <td>Btu/h</td> <td>(6.45 kW)</td> </tr> <tr> <td>Maximum input</td> <td>31,000</td> <td>Btu/h</td> <td>(9.09 kW)</td> </tr> </table>	Min. supply pressure	5"	WC	(1.25 kpa)	Low Setting Man. pressure	1.6"	WC	(0.41 kpa)	Max. Manifold pressure	3.5"	WC	(0.87 kpa)	Orifice size	#37	DMS		Minimum input	22,000	Btu/h	(6.45 kW)	Maximum input	31,000	Btu/h	(9.09 kW)	<table border="0" style="width: 100%;"> <tr> <td>Pression d'alimentation minimale</td> <td></td> </tr> <tr> <td>Pression de sortie (manifold) - basse</td> <td></td> </tr> <tr> <td>Pression de sortie (manifold) - max.</td> <td></td> </tr> <tr> <td>Taille de l'orifice</td> <td></td> </tr> <tr> <td>Débit calorifique minimal</td> <td></td> </tr> <tr> <td>Débit calorifique maximal</td> <td></td> </tr> </table>	Pression d'alimentation minimale		Pression de sortie (manifold) - basse		Pression de sortie (manifold) - max.		Taille de l'orifice		Débit calorifique minimal		Débit calorifique maximal
Min. supply pressure	5"	WC	(1.25 kpa)																																		
Low Setting Man. pressure	1.6"	WC	(0.41 kpa)																																		
Max. Manifold pressure	3.5"	WC	(0.87 kpa)																																		
Orifice size	#37	DMS																																			
Minimum input	22,000	Btu/h	(6.45 kW)																																		
Maximum input	31,000	Btu/h	(9.09 kW)																																		
Pression d'alimentation minimale																																					
Pression de sortie (manifold) - basse																																					
Pression de sortie (manifold) - max.																																					
Taille de l'orifice																																					
Débit calorifique minimal																																					
Débit calorifique maximal																																					
 HRI4E-LP11	PROPANE GAS FIREPLACE INSERT: MODEL HRI4E-LP11 Factory Equipped For Altitude 0-4500ft. (0-1370m)	MODELE HRI4E- LP11 FONCTIONNANT AU GAZ PROPANE																																			
	<table border="0" style="width: 100%;"> <tr> <td>Min. supply pressure</td> <td>11"</td> <td>WC</td> <td>(2.73 kpa)</td> </tr> <tr> <td>Low Setting Man. pressure</td> <td>6.4"</td> <td>WC</td> <td>(1.59 kpa)</td> </tr> <tr> <td>Max. Manifold pressure</td> <td>10"</td> <td>WC</td> <td>(2.48 kpa)</td> </tr> <tr> <td>Orifice size</td> <td>#53</td> <td>DMS</td> <td></td> </tr> <tr> <td>Minimum input</td> <td>26,000</td> <td>Btu/h</td> <td>(7.62 kW)</td> </tr> <tr> <td>Maximum input</td> <td>31,000</td> <td>Btu/h</td> <td>(9.09 kW)</td> </tr> </table>	Min. supply pressure	11"	WC	(2.73 kpa)	Low Setting Man. pressure	6.4"	WC	(1.59 kpa)	Max. Manifold pressure	10"	WC	(2.48 kpa)	Orifice size	#53	DMS		Minimum input	26,000	Btu/h	(7.62 kW)	Maximum input	31,000	Btu/h	(9.09 kW)	<table border="0" style="width: 100%;"> <tr> <td>Pression d'alimentation minimale</td> <td></td> </tr> <tr> <td>Pression de sortie (manifold) - basse</td> <td></td> </tr> <tr> <td>Pression de sortie (manifold) - max.</td> <td></td> </tr> <tr> <td>Taille de l'orifice</td> <td></td> </tr> <tr> <td>Débit calorifique minimal</td> <td></td> </tr> <tr> <td>Débit calorifique maximal</td> <td></td> </tr> </table>	Pression d'alimentation minimale		Pression de sortie (manifold) - basse		Pression de sortie (manifold) - max.		Taille de l'orifice		Débit calorifique minimal		Débit calorifique maximal
Min. supply pressure	11"	WC	(2.73 kpa)																																		
Low Setting Man. pressure	6.4"	WC	(1.59 kpa)																																		
Max. Manifold pressure	10"	WC	(2.48 kpa)																																		
Orifice size	#53	DMS																																			
Minimum input	26,000	Btu/h	(7.62 kW)																																		
Maximum input	31,000	Btu/h	(9.09 kW)																																		
Pression d'alimentation minimale																																					
Pression de sortie (manifold) - basse																																					
Pression de sortie (manifold) - max.																																					
Taille de l'orifice																																					
Débit calorifique minimal																																					
Débit calorifique maximal																																					
Minimum Clearances to Combustibles from Insert <table border="0" style="width: 100%;"> <tr> <td>Side wall</td> <td>A</td> <td>8"</td> <td>(203mm)</td> </tr> <tr> <td>Ceiling</td> <td>B</td> <td>60"</td> <td>(1524mm)</td> </tr> <tr> <td>Mantel</td> <td>C</td> <td>35"</td> <td>(889mm)</td> </tr> <tr> <td>Min. Alcove Width</td> <td>K</td> <td>54"</td> <td>(1372mm)</td> </tr> <tr> <td>Max. Alcove Depth</td> <td>L</td> <td>36"</td> <td>(914mm)</td> </tr> </table>	Side wall	A	8"	(203mm)	Ceiling	B	60"	(1524mm)	Mantel	C	35"	(889mm)	Min. Alcove Width	K	54"	(1372mm)	Max. Alcove Depth	L	36"	(914mm)		Mantel Clearances/Dégagements manteau <table border="0" style="width: 100%;"> <tr> <td>Min. Hearth Width</td> <td>D</td> <td>14"</td> <td>(356mm)</td> </tr> <tr> <td>Min. Hearth Length</td> <td>E</td> <td>40"</td> <td>(1016mm)</td> </tr> <tr> <td>Max. Mantle Depth</td> <td>G</td> <td>12"</td> <td>(305mm)</td> </tr> </table>	Min. Hearth Width	D	14"	(356mm)	Min. Hearth Length	E	40"	(1016mm)	Max. Mantle Depth	G	12"	(305mm)			
Side wall	A	8"	(203mm)																																		
Ceiling	B	60"	(1524mm)																																		
Mantel	C	35"	(889mm)																																		
Min. Alcove Width	K	54"	(1372mm)																																		
Max. Alcove Depth	L	36"	(914mm)																																		
Min. Hearth Width	D	14"	(356mm)																																		
Min. Hearth Length	E	40"	(1016mm)																																		
Max. Mantle Depth	G	12"	(305mm)																																		
MADE IN CANADA /FABRIQUÉ AU CANADA FPI Fireplace Products International Ltd. Delta BC, CANADA																																					
This appliance must be installed in accordance with local codes, if any; if none, follow the National Fuel Gas Code, ANSI Z223.1, or Natural Gas and Propane Installation Code, CSA B149.1. This appliance is only for use with the type of gas indicated on the rating plate. This appliance is not convertible for use with other gases unless a certified kit is used. This appliance is only for use with the type of gas indicated on the rating plate and may be installed in an aftermarket, permanently located, manufactured (mobile) home where not prohibited by local codes. See owner's manual for details. WARNING: This fireplace has been converted for use with a gas fireplace insert only and cannot be used for burning wood or solid fuels unless all original parts have been replaced, and the fireplace re-approved by the authority having jurisdiction. Installer l'appareil selon les codes ou règlements locaux, ou, en l'absence de tels règlements, selon les codes d'installation ANSI Z223.1, National Fuel Gas Code ou CSA-B149.1 en vigueur. Cet appareil doit être utilisé uniquement avec le type de gaz indiqué sur la plaque signalétique. Cet appareil n'est pas convertible pour être utilisé avec d'autres gaz, sauf si une trousse de conversion certifiée est utilisée. Cet appareil doit être utilisé uniquement avec le type de gaz indiqué sur la plaque signalétique et peut être installé dans une maison préfabriquée ou mobile (E.-U. seulement) installée à demeure si les règlements locaux le permettent. Voir le manuel d'utilisation pour plus de renseignements. Cet appareil ne peut pas être utilisé avec d'autres gaz sauf si une trousse de conversion certifiée est fournie. AVERTISSEMENT : Ce foyer a été converti pour être utilisé avec un foyer au gaz encastrable et ne peut être utilisé pour brûler du bois ou d'autres combustibles solides à moins que toutes les pièces d'origine aient été remises en place et que le foyer ait été homologué de nouveau par une autorité compétente. This vented gas fireplace heater is not for use with air filters. Ne pas utiliser de filtre à air avec ce foyer au gaz à évacuation. For use with glass doors certified with the appliance only. Pour utilisation uniquement avec les portes en verre certifiées avec l'appareil. For use only with barrier (Part # 399-100) Follow installation instructions. Pour l'utilisation seulement avec l'écran de sécurité (Pièce n° 399-100) Electrical supply / Alimentation électrique 115VAC, 2.5 A, 60Hz, Less than 10A Fan/Ventilateur Part # 911-071																																					
VENTED GAS FIREPLACE HEATER - NOT FOR USE WITH SOLID FUELS. CATEGORY I. / FOYER AU GAZ À ÉVACUATION - NE PAS UTILISER AVEC UN COMBUSTIBLE SOLIDE. CATÉGORIE I.																																					
	CSA P.4.1 Fireplace Efficiency (FE) /Efficacité énergétique des foyers (EEF) CSA P.4.1 Natural Gas / Gaz naturel 70.27% Propane Gas / Gaz propane 69.36%	919-935c																																			

For the State of Massachusetts, installation and repair must be done by a plumber or gas fitter licensed in the Commonwealth of Massachusetts.

For the State of Massachusetts, flexible connectors shall not exceed 36 inches in length.

For the State of Massachusetts, the appliances individual manual shut-off must be a t-handle type valve.

The State of Massachusetts requires the installation of a carbon monoxide alarm in accordance with NFPA 720 and a CO alarm with battery back up in the same room where the gas appliance is installed.

**MA Code - CO Detector
(for the State of Massachusetts only)**

5.08: Modifications to NFPA-54, Chapter 10

(2) Revise 10.8.3 by adding the following additional requirements:

(a) For all side wall horizontally vented gas fueled equipment installed in every dwelling, building or structure used in whole or in part for residential purposes, including those owned or operated by the Commonwealth and where the side wall exhaust vent termination is less than seven (7) feet above finished grade in the area of the venting, including but not limited to decks and porches, the following requirements shall be satisfied:

1. **INSTALLATION OF CARBON MONOXIDE DETECTORS.** At the time of installation of the side wall horizontal vented gas fueled equipment, the installing plumber or gasfitter shall observe that a hard wired carbon monoxide detector with an alarm and battery back-up is installed on the floor level where the gas equipment is to be installed. In addition, the installing plumber or gasfitter shall observe that a battery operated or hard wired carbon monoxide detector with an alarm is installed on each additional level of the dwelling, building or structure served by the side wall horizontal vented gas fueled equipment. It shall be the responsibility of the property owner to secure the services of qualified licensed professionals for the installation of hard wired carbon monoxide detectors

a. In the event that the side wall horizontally vented gas fueled equipment is installed in a crawl space or an attic, the hard wired carbon monoxide detector with alarm and battery back-up may be installed on the next adjacent floor level.

b. In the event that the requirements of this subdivision can not be met at the time of completion of installation, the owner shall have a period of thirty (30) days to comply with the above requirements; provided, however, that during said thirty (30) day period, a battery operated carbon monoxide detector with an alarm shall be installed.

2. **APPROVED CARBON MONOXIDE DETECTORS.** Each carbon monoxide detector as required in accordance with the above provisions shall comply with NFPA 720 and be ANSI/UL 2034 listed and IAS certified.

3. **SIGNAGE.** A metal or plastic identification plate shall be permanently mounted to the exterior of the building at a minimum height of eight (8) feet above grade directly in line with the exhaust vent terminal for the horizontally vented gas fueled heating appliance or equipment. The sign shall read, in print size no less than one-half (1/2) inch in size, "**GAS VENT DIRECTLY BELOW. KEEP CLEAR OF ALL OBSTRUCTIONS**".

4. **INSPECTION.** The state or local gas inspector of the side wall horizontally vented gas fueled equipment shall not approve the installation unless, upon inspection, the inspector observes carbon monoxide detectors and signage installed in accordance with the provisions of 248 CMR 5.08(2)(a)1 through 4.

(b) **EXEMPTIONS:** The following equipment is exempt from 248 CMR 5.08(2)(a)1 through 4:

1. The equipment listed in Chapter 10 entitled "Equipment Not Required To Be Vented" in the most current edition of NFPA 54 as adopted by the Board; and

2. Product Approved side wall horizontally vented gas fueled equipment installed in a room or structure separate from the dwelling, building or structure used in whole or in part for residential purposes.

(c) **MANUFACTURER REQUIREMENTS - GAS EQUIPMENT VENTING SYSTEM PROVIDED.** When the manufacturer of Product Approved side wall horizontally vented gas equipment provides a venting system design or venting system components with the equipment, the instructions provided by the manufacturer for installation of the equipment and the venting system shall include:

1. Detailed instructions for the installation of the venting system design or the venting system components; and

2. A complete parts list for the venting system design or venting system.

(d) **MANUFACTURER REQUIREMENTS - GAS EQUIPMENT VENTING SYSTEM NOT PROVIDED.** When the manufacturer of a Product Approved side wall horizontally vented gas fueled equipment does not provide the parts for venting the flue gases, but identifies "special venting systems", the following requirements shall be satisfied by the manufacturer:

1. The referenced "special venting system" instructions shall be included with the appliance or equipment installation instructions; and

2. The "special venting systems" shall be Product Approved by the Board, and the instructions for that system shall include a parts list and detailed installation instructions.

(e) A copy of all installation instructions for all Product Approved side wall horizontally vented gas fueled equipment, all venting instructions, all parts lists for venting instructions, and/or all venting design instructions shall remain with the appliance or equipment at the completion of the installation.

dimensions

GAS INSTALLATION CHECKLIST

This general checklist does not contain all pertinent installation details or specifics and does not supersede the guidelines in this manual. Your Regency dealer/installer should use it in conjunction with manual instructions. Please follow all local codes and jurisdictions in authority.

Customer: _____	Date Installed: _____
Install Address: _____	Location of Fireplace: _____
Serial No: _____	Installer: _____
Model No: _____	
Site Requirements	YES NO
If applicable, are the insulation, vapour barrier, and drywall present if installed on an outside wall or chase?	
Does the area have a solid continuous base to support the unit?	
Will the area accommodate the size of the appliance and all clearances?	
Are the gas and electrical roughed into the area where the unit is being installed?	
In City & Grandview series cool wall applications, is the chase enclosure sealed to prevent heat from escaping? All hot air from the unit must exit via the mandatory ventilation openings.	
In City & Grandview applications, Is the chase enclosure vented with the mandatory heat ventilation openings? See manual for details.	
If applicable, is the masonry/factory built fireplace in its original condition with no modifications?	
If applicable, have the hearth requirements been met?	
Unit Setup	YES NO
If applicable, are the standoffs and top nailing flange extensions installed and at the correct depth to accommodate finishing material? See manual for details.	
If applicable, is the fireplace level and secured, meeting framing clearances? See manual for details.	
If applicable, is the unit converted to top or rear vent per manual instructions, and the insulation discarded?	
Venting	YES NO
Are the venting components approved for the unit installed?	
Does the venting configuration comply with venting diagrams?	
Is venting installed and secured, and are clearances for the vent pipe and termination cap maintained?	
If applicable, was a 1/4" rise maintained for every foot of horizontal run?	
Was the termination installed and sealed?	
Is the direct vent termination at the highest point in the vent assembly?	
If applicable, are both chimney liners continuous from flue collars to termination?	
Electrical and Wiring	YES NO
Is the appliance connected to the household's 110/120v per local codes? Check local codes for receptacle placement.	
Were the connections in the fireplace tested with a circuit tester?	
Is the appliance properly grounded?	
If applicable, is the supplied electrical/gang box affixed to the wall to facilitate the mounting of the receiver/battery box ?	
If applicable, is all electrical, Ethernet, HDMI, networking, optical, wire/cables, conduits, etc. run through the wood or steel stud work as wires/cables of any kind cannot be exposed directly above or over the fireplace?	
Gas	YES NO
Does the supply pressure meet the requirements shown on the rating plate?	
Was a conversion performed?	
Was a leak check performed and manifold pressures verified?	

Is the shut-off valve installed and easily accessible to the customer?		
Finishing	YES	NO
If applicable, is only noncombustible material installed in the noncombustible areas?		
Do clearances meet installation and manual requirements?		
Do the mantels and/or projections comply with the installation manual?		
If applicable, was the solid fuel fireplace warning plate installed?		
Is the chase enclosure fully open the full width, height and depth above the fireplace as per the requirements noted in the framing section?		
Appliance Media Setup	YES	NO
Do commands from the remote or wall switch light the pilot and main burner?		
Are the burner media/log set, glass door, and screen installed per instructions in the manual?		
Was the air shutter on the proper setting after running the unit for 20 minutes?		
If applicable, were the surround and trims installed according to the manual?		
Was the operation of the fan, lights (if installed), and flame modulation checked?		
Customer Tutorial and Presentation	YES	NO
Is the customer confident operating the new gas appliance and aware of all the features on the remote?		
Confirm that the rating and lighting plates are attached to the appliance. Do not remove.		
Was the customer informed of the location of the rating and lighting plates?		
Was accessing unit controls in a power outage explained to the customer?		
Are the model and serial numbers and the date of installation of the unit written in the manual and on the checklist?		
Were the warranty and unit registration reviewed with the customer?		
Comments:		

IMPORTANT MESSAGE SAVE THESE INSTRUCTIONS

The LRI4E / HRI4E Gas Inserts must be installed in accordance with these instructions. Carefully read all the instructions in this manual first. Consult the "authority having jurisdiction" to determine the need for a permit prior to starting the installation. It is the responsibility of the installer to ensure this fireplace is installed in compliance with manufacturers instructions and all applicable codes.

BEFORE YOU START

Safe installation and operation of this appliance requires common sense, however, we are required by the Canadian Safety Standards and ANSI Standards to make you aware of the following:

INSTALLATION AND REPAIR SHOULD BE DONE BY AN AUTHORIZED SERVICE PERSON. THE APPLIANCE SHOULD BE INSPECTED BEFORE USE AND AT LEAST ANNUALLY BY A PROFESSIONAL SERVICE PERSON. MORE FREQUENT CLEANING MAY BE REQUIRED DUE TO EXCESSIVE LINT FROM CARPETING, BEDDING MATERIAL, ETC. IT IS IMPERATIVE THAT CONTROL COMPARTMENTS, BURNERS AND CIRCULATING AIR PASSAGEWAYS OF THE APPLIANCE BE KEPT CLEAN.

DUE TO HIGH TEMPERATURES, THE APPLIANCE SHOULD BE LOCATED OUT OF TRAFFIC AND AWAY FROM FURNITURE AND DRAPERIES.

WARNING: FAILURE TO INSTALL THIS APPLIANCE CORRECTLY WILL VOID YOUR WARRANTY AND MAY CAUSE A SERIOUS HOUSE FIRE.

CHILDREN AND ADULTS SHOULD BE ALERTED TO THE HAZARDS OF HIGH SURFACE TEMPERATURES, ESPECIALLY THE FIREPLACE GLASS, AND SHOULD STAY AWAY TO AVOID BURNS OR CLOTHING IGNITION.

YOUNG CHILDREN SHOULD BE CAREFULLY SUPERVISED WHEN THEY ARE IN THE SAME AREA AS THE APPLIANCE. TODDLERS, YOUNG CHILDREN AND OTHERS MAY BE SUSCEPTIBLE TO ACCIDENTAL CONTACT BURNS. A PHYSICAL BARRIERS IS RECOMMENDED IF THERE ARE AT RISK INDIVIDUAL IN THE HOUSE. TO RESTRICT ACCESS TO A FIREPLACE OR STOVE, INSTALL AN ADJUSTABLE SAFETY GATE TO KEEP TODDLERS, YOUNG CHILDREN AND OTHER AT RISK INDIVIDUALS OUT OF THE ROOM AND AWAY FROM HOT SURFACES.

CLOTHING OR OTHER FLAMMABLE MATERIAL SHOULD NOT BE PLACED ON OR NEAR THE APPLIANCE.

A BARRIER DESIGNED TO REDUCE THE RISK OF BURNS FROM THE HOT VIEWING GLASS IS PROVIDED WITH THIS APPLIANCE AND SHALL BE INSTALLED FOR THE PROTECTION OF CHILDREN AND OTHER AT-RISK INDIVIDUALS

IF THE BARRIER BECOMES DAMAGED, THE BARRIER SHALL BE REPLACED WITH THE MANUFACTURER'S BARRIER FOR THIS APPLIANCE.

ANY SAFETY SCREEN, GUARD, OR BARRIER REMOVED FOR SERVICING AN APPLIANCE MUST BE REPLACED PRIOR TO OPERATING THE APPLIANCE.



IMPORTANT MESSAGE SAVE THESE INSTRUCTIONS

The Regency Gas Insert must be installed in accordance with these instructions. Carefully read all the instructions in this manual first. Consult the building authority having jurisdiction to determine the need for a permit prior to starting the installation.

NOTE: Failure to follow the instructions could cause a malfunction of the heater which could result in death, serious bodily injury, and/or property damage. Failure to follow these instructions may also void your fire insurance and/or warranty.

FOR YOUR SAFETY

This appliance requires air for proper combustion. Always provide adequate combustion and ventilation air. Follow instructions and information in CSA B149.1 (in Canada) or the National Fuel Gas Code ANSI Z223.1 (in the USA), regarding requirements for combustion and ventilation air.

SPECIFICATIONS

At pressures over 1/2 psig, the pipe to the unit must be disconnected.

Gas Input Capacity:

Natural Gas	31,000	Btu/h
Propane	31,000	Btu/h

Min. Input

(with Proflame GTM or GTMF remote)

Natural Gas	22,000	Btu/h
Propane	26,000	Btu/h

Fuels: Approved for use with both natural gas, and propane. Approved as is for use at 0' to 4,500' (0-1370m).

Electrical: 120V A.C. system.

Circulation Fan: Variable speed, 140 CFM.

Log Set: Ceramic fibre, 7 per set - LRI4E

Glass Crystals: 7lbs of glass crystals - HRI4E

Optional Log Set: Ceramic fibre, 6 per set + 5lbs of glass crystals - HRI4E

Vent System: 3" co-linear aluminum flex.

The efficiency rating of the appliance is a product thermal efficiency rating determined under continuous operating conditions and was determined independent of any installed system.

 **WARNING: Cancer and Reproductive Harm**
www.P65Warnings.ca.gov

919-874

LIGHTING PROCEDURE

IMPORTANT: The remote control system supplied with this appliance has several options for starting/operating the appliance using the power button and ON/OFF key on the hand held transmitter. Prior to operating this appliance, please read the remote control operating instructions (packaged with remote control) to understand how to operate this remote control system. Option to download remote functions video with QR code below.



Proflame video

1. Ensure the wall switch/receiver is in the remote position. (see Diagram 1).

Set Switch to Remote

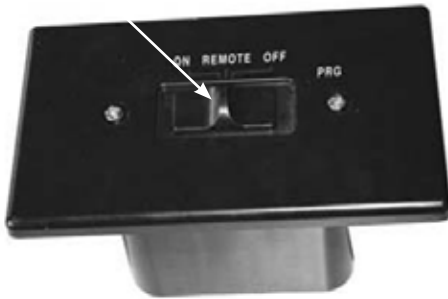
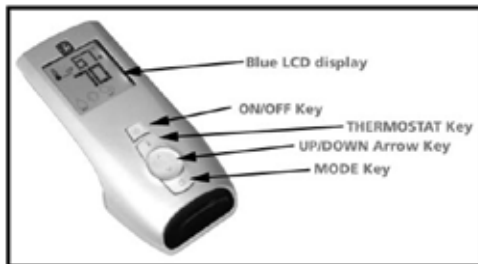

Diagram 1

2. Press and release the ON/OFF button on the remote handheld transmitter (see Diagram 2). An audible beep should be heard from the receiver.



Diagram 2
Remote shown in Manual Mode on Hi



Note: May not be exactly as shown as hand-held may be silver or black.

3. After approximately 4 seconds the spark ignition system will spark for 60 seconds to light the pilot.
4. The unit will turn on.

Note: The first try for ignition will last approximately 60 seconds. If there is no flame ignition (rectification) the board will stop sparking for approximately 35 seconds. After wait time, the board will start second try for ignition by sparking for approximately 60 seconds. If there is still no positive ignition the board will go into lock out.

The system will need to be reset as follows:

- a) Turn the system off using ON/OFF switch or press ON/OFF button - if using remote.
- b) After approximately 2 seconds turn on ON/OFF switch or press ON/OFF button if using remote.
- c) Repeat step 2.

SHUTDOWN PROCEDURE

1. Turn the wall mounted switch or remote to the "OFF" position.
2. Press "OFF" on the remote control.
3. Turn the gas control knob to the "OFF" position to turn off the pilot.

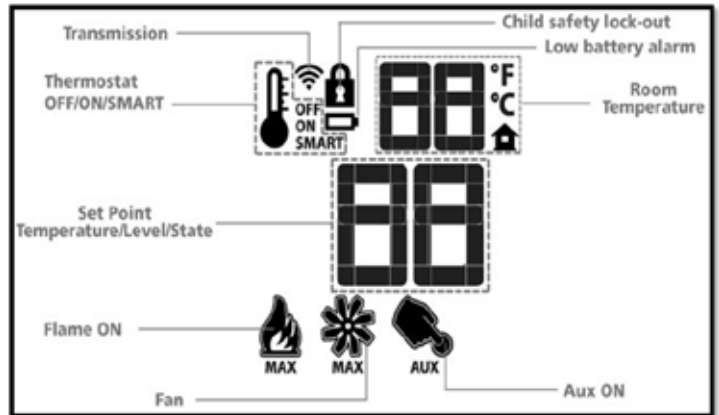

COPY OF THE LIGHTING PLATE INSTRUCTIONS

**FOR YOUR SAFETY READ BEFORE LIGHTING
POUR VOTRE SÉCURITÉ – À LIRE AVANT LA MISE EN MARCHÉ**

WARNING: If you do not follow these instructions exactly, a fire or explosion may result causing property damage, personal injury or loss of life. Improper installation, adjustment, alteration, service or maintenance can cause injury or property damage. Refer to the owner's information manual provided with this appliance. For assistance or additional information consult a qualified installer, service agency or gas supplier.

AVERTISSEMENT : Quiconque ne respecte pas scrupuleusement les instructions de la présente notice risque de déclencher un incendie ou une explosion pouvant entraîner des dégâts matériels ou des blessures pouvant être mortelles. Tout défaut d'installation, de réglage, de modification, de service ou d'entretien peut entraîner des blessures ou des dommages matériels. Reportez-vous au manuel d'utilisation fourni avec cet équipement. Pour obtenir de l'aide ou des informations complémentaires, consulter un installateur ou un service d'entretien qualifié, ou le fournisseur de gaz.

- A) This appliance is equipped with an ignition device which automatically lights the pilot.
Do not try to light the pilot by hand.
- B) **BEFORE OPERATING** smell all around the appliance area for gas. Be sure to smell next to the floor because some gas is heavier than air and will settle on the floor.
WHAT TO DO IF YOU SMELL GAS
- Do not try to light any appliance.
 - Do not touch any electric switch, do not use any phone in your building.
 - Leave the building immediately.
 - Immediately call your gas supplier from a neighbours phone. Follow the gas supplier's instructions.
 - If you cannot reach your gas supplier, call the fire department.
- C) Do not use this appliance if any part has been under water. Immediately call a qualified service technician to inspect the appliance and to replace any part of the control system and any gas control which has been underwater.
- A) Cet appareil est muni d'un dispositif d'allumage qui allume automatiquement la veilleuse.
Ne tentez pas d'allumer la veilleuse manuellement.
- B) **AVANT LA MISE EN MARCHÉ**, reniflez tout autour de l'appareil pour détecter une odeur de gaz. Reniflez au niveau du plancher, car certains gaz sont plus lourds que l'air et peuvent s'accumuler au niveau du sol.
- QUE FAIRE SI VOUS SENTEZ UNE ODEUR DE GAZ :**
- Ne tentez pas d'allumer l'appareil.
 - Ne touchez à aucun interrupteur; n'utilisez pas le téléphone se trouvant dans le bâtiment.
 - Quittez immédiatement le bâtiment.
 - Appelez immédiatement votre fournisseur de gaz depuis un téléphone extérieur. Suivez les instructions du fournisseur.
 - Si vous ne pouvez pas rejoindre le fournisseur, appelez le service incendie.
- C) N'utilisez pas cet appareil s'il a été plongé dans l'eau, même partiellement. Faites inspecter l'appareil par un technicien qualifié et remplacez tout élément du système de contrôle ou de commande qui a été plongé dans l'eau.

CAUTION: Hot while in operation. Do not touch. Severe burns may result. Due to high surface temperatures keep children, clothing and furniture, gasoline and other liquids having flammable vapors away. Keep burner and control compartment clean. See installation and operating instructions accompanying appliance.

ATTENTION : Surfaces chaudes lorsque l'appareil est en marche. Ne pas toucher. Risque de brûlures graves. En raison des températures élevées, les enfants, les vêtements et le mobilier, le carburant et tout autre liquide aux vapeurs inflammables doivent être tenus éloignés de l'appareil. Nettoyer régulièrement le brûleur et le compartiment des commandes. Voir les consignes d'installation et d'utilisation fournies avec l'appareil.

OPERATING INSTRUCTIONS / CONSIGNES DE FONCTIONNEMENT

- 1) **STOP! Read the safety information above on this label.**
 - 2) Ensure the Main switch is in the ON position and/or the wall mounted battery holder (if equipped) is in the <REMOTE> position.
 - 3) Press and release the ON/OFF button on the remote handheld transmitter. An audible beep should be heard from the receiver. If not using the remote, the unit can also be turned on by sliding the battery holder switch to the <ON> position (if equipped).
 - 4) After approximately 4 seconds the spark ignition system will spark for 60 seconds to light the main burner.
 - 5) The unit will turn on.
- Note:** The first attempt to ignition will last approximately 60 seconds. If there is no flame ignition (rectification) the board will stop sparking for approximately 35 seconds. After this wait time, the board will start a second try for ignition by sparking for approximately 60 seconds. If there is still no positive ignition after the second attempt the board will go into lock out mode.
The system will need to be reset as follows (after going into lock out mode):
- a) Wait 5 minutes - turn the system off by pressing the ON/OFF button on the remote.
 - b) After approximately 2 seconds press the ON/OFF button again.
 - c) Unit will repeat step 2.
- 6) If the appliance will not operate, follow the instructions, "To Turn Off Gas to Appliance" and call your service technician or gas supplier. This appliance is equipped with an on-demand pilot that shuts off after seven days.
- 1) **STOP! Lisez les instructions de sécurité sur la portion supérieure de cette étiquette.**
 - 2) S'assurer que le commutateur principal est en position ON et/ou que le bloc-piles mural (le cas échéant) est en position <REMOTE>.
 - 3) Appuyer sur la touche ON/OFF de la télécommande puis relâcher. Un bip sonore retentira depuis le récepteur. Si vous n'utilisez pas la télécommande, l'appareil peut également être allumé en faisant glisser le commutateur du bloc-piles sur la position <ON> (le cas échéant).
 - 4) Après environ 4 secondes, le système d'allumage produira une étincelle pendant 60 secondes pour allumer le brûleur principal.
 - 5) L'appareil s'allumera.
- Remarque :** Au premier allumage, le système tente d'allumer les flammes pendant 60 secondes. Si l'essai est infructueux, le système fera une pause de 35 secondes. C'est ce qu'on appelle l'étape de rectification. Ce délai écoulé, le système tente à nouveau d'allumer les flammes en produisant des étincelles pendant 60 secondes. Si les flammes ne s'allument toujours pas, le système se met en mode verrouillage.
Il faut alors le réinitialiser en suivant les étapes ci-dessous (pour le déverrouiller) :
- a) Attendre 5 minutes et éteindre l'appareil en appuyant sur la touche ON/OFF de la télécommande.
 - b) Attendre 2 secondes et appuyer encore une fois sur la touche ON/OFF.
 - c) L'appareil répétera l'étape 2.
- 6) Si l'appareil ne fonctionne pas, suivez les instructions "Pour couper le gaz au niveau de l'appareil" et appelez un technicien qualifié ou votre fournisseur de gaz.
Cet appareil est équipé d'une veilleuse sur demande qui s'éteint après sept jours.

TO TURN OFF GAS TO APPLIANCE / POUR COUPER LE GAZ AU NIVEAU DE L'APPAREIL

- 1) Press the ON/OFF button on the remote or slide the wall mount switch to the "OFF" position.
 - 2) If service is to be performed—you must disconnect power and shut off gas to the unit.
- 1) Appuyer sur la touche ON/OFF de la télécommande ou faites glisser l'interrupteur mural sur la position "OFF".
 - 2) Lors de l'entretien de l'appareil, vous devez débrancher l'alimentation électrique et couper le gaz alimentant l'appareil.

DO NOT REMOVE THIS INSTRUCTION PLATE

NE PAS ENLEVER CETTE ÉTIQUETTE D'INSTRUCTIONS

919-649b

PROFLAME I REMOTE CONTROL OPERATING INSTRUCTIONS

IMPORTANT:The Proflame Transmitter 1 is an integrated part of the Proflame 1 System, which consists of these elements:

- Proflame 1 Transmitter, to be used in conjunction with:
- Integrated Fireplaces Control (Proflame 1 DFG)

The Proflame 1 Transmitter provides for controlling the following hearth appliance functions:

1. Main Burner On/Off
2. Main Burner flame modulation (6 levels)
3. Thermostat and Smart thermostat functions
4. Accent light modulation (6 levels)**
5. Comfort Fan speed modulation (6 levels)**

** This feature is not available on all models.

The Proflame Transmitter uses a streamline design with a simple button layout and informative LCD display (Fig. 1). A Mode Key is provided to index between the features and a Thermostat Key is used to turn on/off or index through Thermostat functions (Fig. 1 & 2). Additionally, a Key Lock feature is provided (Fig. 22).



Figure 1: Proflame Transmitter

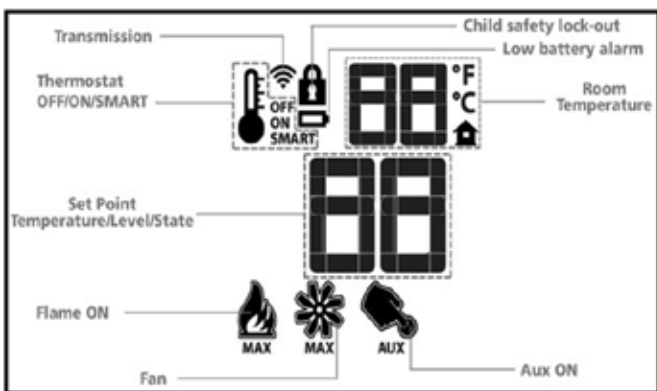

Figure 2: Transmitter LCD Display

Note: May not be exactly as shown as hand-held may be silver or black.

TECHNICAL DATA REMOTE CONTROL	
Supply Voltage	4.5V (three 1.5V AAA batteries)
Ambient temperature ratings	0 - 50°C (32 - 122°F)
Radio Frequency	315 MHZ

WARNING: THE TRANSMITTER AND RECEIVER ARE RADIO FREQUENCY DEVICES. PLACING THE RECEIVER IN OR NEAR METAL MAY SEVERELY REDUCE THE SIGNAL RANGE.

ATTENTION!

- Turn "OFF" the main gas supply of the appliance during installation or maintenance of the Receiver device.
- Turn "OFF" main gas supply to the appliance prior to removing or reinserting the batteries.
- In case of remote control malfunction, turn off the IFC device using the "ON/OFF" main switch.
- For installation / maintenance, switch off the IFC device removing main power supply plug.

OPERATING PROCEDURE

Pairing the remote control to remote receiver/ battery holder (if required)

Power the receiver. Press the PRG button located on the top right hand corner of receiver, see the receiver instruction(*). The Receiver will "beep" three (3) times to indicate that it is ready to synchronize with a Transmitter. Install the 3 AAA type batteries in the Transmitter battery bay, located on the base of the Transmitter. (fig. 3) With the batteries already installed in the Transmitter, push the On button. The Receiver will "beep" four times to indicate the Transmitter's command is accepted and sets to the particular code of that Transmitter. The system is now initialized.

(*)The receiver may be independent or integral to the IFC hearth appliance control module. The receiver instruction may not be independent when part of the IFC.

Note: Only use regular alkaline batteries. Do not use rechargeable or lithium batteries.



Figure 3: Battery Compartment

Smart Thermostat (Transmitter Operation)

The Smart Thermostat function adjusts the flame height in accordance to the difference between the set point temperature and the actual room temperatures. As the room temperature gets closer to the set point the Smart Function will modulate the flame down.

To activate this function, press the Thermostat Key (Fig. 1) until the word "SMART" appears to the right of the temperature bulb graphic (Fig. 11).

To adjust the set temperature, press the Up or Down Arrow Keys until the desired set temperature is displayed on the LCD screen of the Transmitter (Fig. 12).

Note. When Smart Thermostat is activated, manual flame height adjustment is disabled.

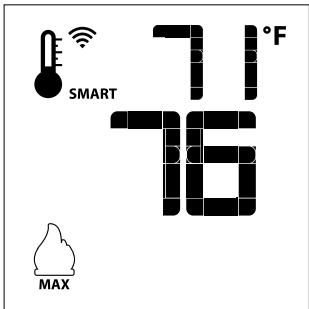

Figure 11: Smart Flame Function

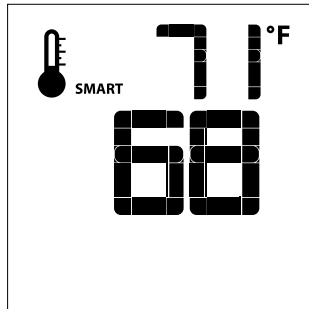

Figure 12

Fan Speed Control**

If the appliance is equipped with a hot air circulating fan, the speed of the fan can be controlled by the Proflame system. The fan speed can be adjusted through six (6) speeds. To activate this function use the Mode Key (fig.1) to index to the fan control icon (Fig. 13). Use the Up/Down Arrow Keys (fig.1) to turn on, off or adjust the fan speed (fig. 14). A single "beep" will confirm reception of the command.



Figure 13

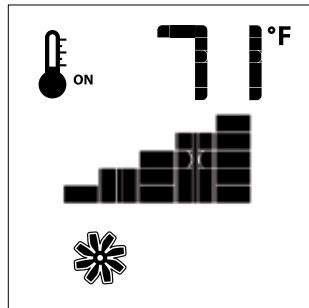

Figure 14

Remote dimmer control (Light)**

The auxiliary function controls the AUX power outlet by the dimmable light control. To activate this function use the Mode Key (fig. 1) to index to the AUX icon (fig. 15 & 16).

The intensity of the output can be adjusted through six (6) levels. Use the Up/Down Arrow Keys (Fig.1) adjust the output level (Fig. 16). A single "beep" will confirm reception of the command.

Note: This function is available only with the IFC Control Module.

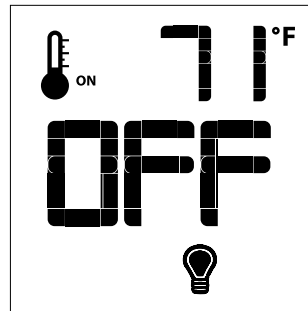

Figure 15

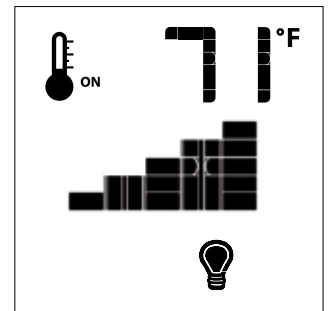

Figure 16

Split Flow control**

The secondary burner is controlled by the split Flow. To activate this function use the Mode Key (fig. 1) to index to the SPLIT FLOW mode icon (fig. 17 & 18).

Pressing the Up Arrow Key will activate the secondary burner. Pressing the Down Arrow Key will turn the secondary burner off. A single "beep" will confirm the reception of the command.

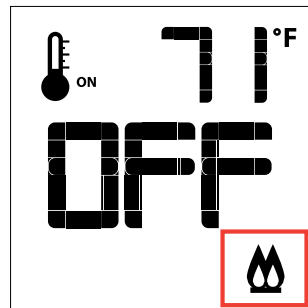

Figure 17

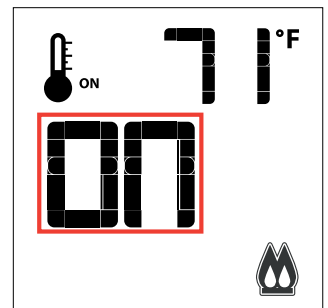

Figure 18

CPI/IPI Switch

This appliance comes equipped with a CPI/IPI switch. The functions of the CPI/IPI switch are as follows:

Continuous pilot (CPI) - A pilot that, once placed in operation, is intended to remain ignited continuously until it is manually interrupted.

Intermittent pilot (IPI) - A pilot that is automatically ignited when an appliance is called on to operate and which remains continuously ignited during each period of main burner operation. The pilot is automatically extinguished when each main burner operating cycle is completed

The mode of the fireplace is easily changed from an intermittent pilot ignition system (IPI) to a continuous pilot ignition system (CPI) by using the silver toggle switch located on the fireplace.
(See noted location of CPI/IPI Switch)

The benefits of having CPI are as follows:

- Keeps venting primed for trouble free start-up under colder weather conditions or inversions.
- Keeps the unit glass warm, which decreases the amount of condensation on start-up.
- Provides owners with flexibility to choose a traditional continuous pilot. (7 day/Pilot on Demand)

The primary benefit of having the IPI function is a significant savings on fuel as the pilot will only run when there is a call for heat.

ENABLE / DISABLE functions on the Proflame I remote only.

1. Remove one battery from the remote.
2. Press and hold both the **ON/OFF** and the **MODE** button at the same time
3. Reinstall the battery (removed in Step 1) while still holding both buttons (keep holding both buttons and once all batteries are installed then release the **MODE** button only).
4. The screen will show **CFG**.
5. Use the up or down arrow button to program out the function on the remote.

Note: You should never program out the fan (If installed) feature on the remote. It is not possible to remove the thermostat mode on this remote control.



The Surefire switch is located at the bottom left corner of the unit.

Thermostat Icon: If the thermostat icon is not present on the remote transmitter, follow instructions noted below:

1. Remove one battery from the remote.
2. Press and hold down the Thermostat button on the remote.
3. Reinstall the battery(removed in Step 1) while still holding down thermostat button.
4. If you see "**Set**" the thermostat option is now enabled. If you see "**Clr**" the thermostat option is now disabled.
5. Repeat the procedure if the "**Set**" or "**Clr**" to remove or add the option back to the remote did not appear.

Enable all other functions if not present on the remote transmitter, follow instructions noted below:

1. Remove one battery from remote.
2. Press and hold both the **ON/OFF** and **MODE** button at the same time .
3. Reinstall battery removed in Step 1 while holding both buttons— keep holding buttons, then release the **MODE** button only.
4. The screen will show either "**Clr**" or "**Set**" as the first option available is to disable or enable a mode.
5. "**Clr**" will remove a mode—use the up or down arrow while holding down **ON/OFF** and **MODE** (mode icon will disappear once removed).
6. Use the "**MODE**" button to move to the next function.
7. "**Set**" will add a mode —use the up or down arrow while holding down **ON/OFF** and **MODE** (mode icon will appear when added).
8. Use the "**MODE**" button to move to the next function.

Note: You should never program out the fan (if installed) or CPI/IPI mode on the remote.

KEY LOCK

This function will lock the keys to avoid unsupervised operation. To activate this function, press the MODE and UP Keys at the same time (fig. 21). To de-activate this function, press the MODE and UP Keys at the same time.

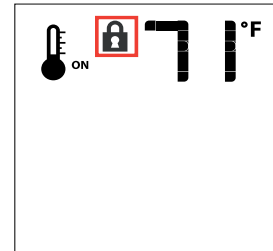

Figure 21

LOW BATTERY POWER DETECTION

Transmitter

The life span of the remote control batteries depends on various factors: quality of the batteries used, the number of ignitions of the appliance, the number of changes to the room thermostat set point, etc. When the Transmitter batteries are low, a Battery Icon will appear on the LCD display of the Transmitter (Fig. 22) before all battery power is lost. When the batteries are replaced this Icon will disappear.

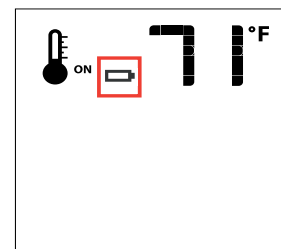

Figure 22

PROFLAME I REMOTE RECEIVER BATTERY REPLACEMENT & BATTERY BACKUP IF 120V POWER IS LOST WITHIN HOME

How to replace/add the batteries on remote receiver when 120 volt power is lost & fan control module is installed.

Batteries are only required in the remote receiver when 120 volt power is lost within home. The fan control module supplied with this appliance is also an AC adaptor.

The safety screen will need to be removed to gain access to the remote receiver located on the lower left hand side of appliance. Follow steps below to replace/add batteries.

How to replace/add the batteries on remote receiver (Proflame 1).

Note : If a wall switch cover plate is installed, first remove cover plate by removing 2 small phillips head screws

STEP 1

Move both the left/right slides as shown below.

The battery compartment will be pushed out slightly, to allow to easily extract it

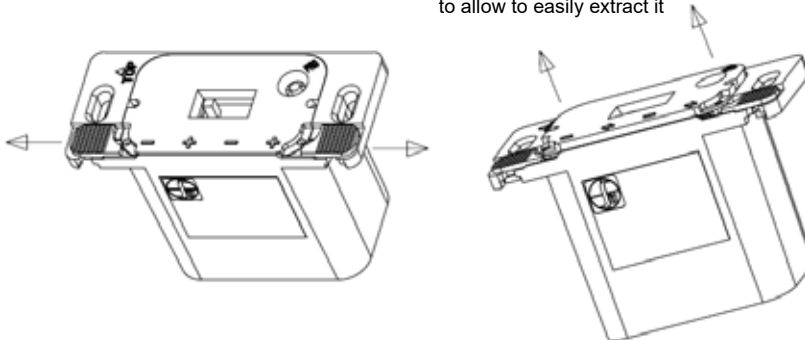

STEP 2

Extract the battery compartment from the remote receiver/battery holder

Replace 4 x AA batteries and insert the battery compartment back into remote receiver/battery holder

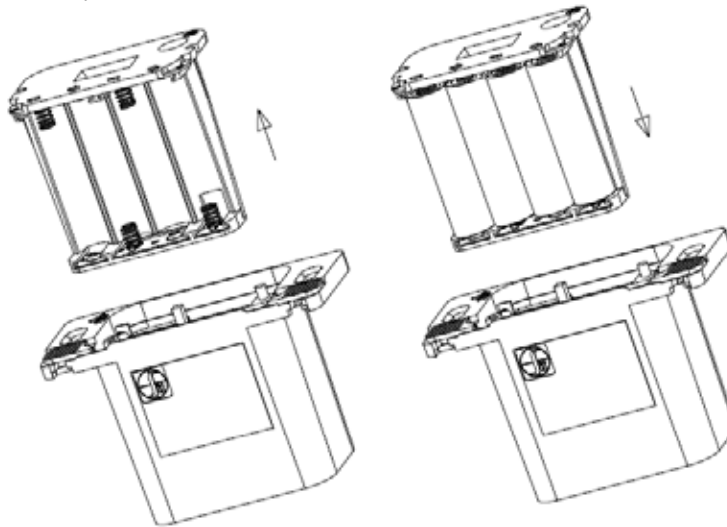

STEP 3

Keeping the battery compartment pressed in, close the left slide

Close the right slide

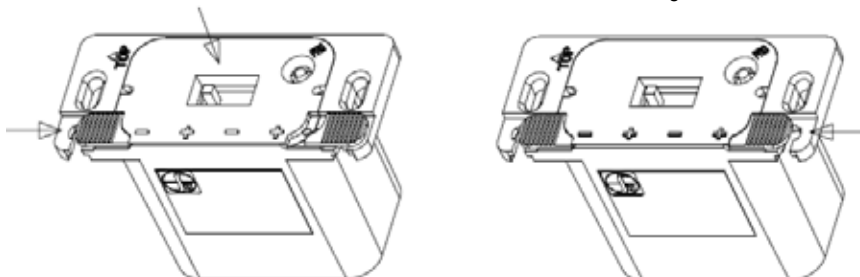

STEP 4 Reinstall safety screen.

GAS PRESSURE TESTING

The appliance must be isolated from the gas supply piping system by closing its individual manual shut off valve during any pressure testing of the gas supply piping system at test pressures equal to or less than 1/2 psig. (3.45 kPa).

INSTALLATION INTO A SOLID FUEL BURNING FIREPLACE OR FACTORY BUILT FIREPLACE

The LRI4E / HRI4E Gas Inserts have been tested and approved to be vented into any masonry fireplace or approved solid fuel burning factory built fireplace that will allow the insert to physically fit into the firebox. Refer to "Minimum Fireplace Dimensions" section for minimum fireplace clearances.

If the factory built fireplace* height is too low for your Insert, you may remove the smoke baffle plate, damper, refractory (firebricks), glass doors, screen rails, screen mesh and log grates from the factory built fireplace as long as these items are saved and are reinstalled in the event that the Insert is removed. The fireplace flue damper can be fully blocked open or removed for installation of the gas fireplace insert.

Smoke shelves, shields and baffles may be removed if attached by mechanical fasteners. If any part is removed it must not weaken the structural integrity of the factory built fireplace.

The fireplace and fireplace chimney must be clean and in good working order and constructed of non-combustible materials.

The surround panels should not seal ventilation openings on the fireplace.

Chimney clean outs should fit properly.

NOTE: Any alterations made to the listed solid fuel burning factory built fireplace may void the listing of the fireplace.

Cutting any sheet metal part of the fireplace, in which the gas fireplace insert is to be installed is prohibited.

*Check with your local inspector before commencing with this installation.

Installer must mechanically attach the supplied label to the inside of the firebox of the fireplace into which the gas fireplace insert is installed.

WARNING: This fireplace has been converted for use with a gas fireplace insert only and cannot be used for burning wood or solid fuels unless all original parts have been replaced, and the fireplace re-approved by the authority having jurisdiction."

FACTORY-BUILT (METAL) WOOD-BURNING FIREPLACE REQUIREMENTS

NOTE: Any parts that are removed must be removed in a way that would allow them to be re-installed if the insert is ever removed (removal of rivets or screws is acceptable).

To reference parts—see illustration below.

Must be removed:

- 1 - Damper
- 2 - Grate (with log set)

May be removed (if applicable):

- 3 - Smoke shelf
- 4 - Internal baffles
- 5 - Screen
- 6 & 7 - Masonry lining or refractory
- 8 - Metal or glass doors

The fireplace must be permanently marked to indicate that it has been altered and is no longer suitable for burning solid fuel (wood), unless the removed parts are re-installed. Cutting of any sheet metal parts is prohibited.

May be removed (in certain cases):

- 9 - Metal floor of the firebox
- 10 - The insulation and any structured rigid frame members must not be removed or altered (side and top of door frame, side and top of the face of the fireplace, metal sides, etc.).

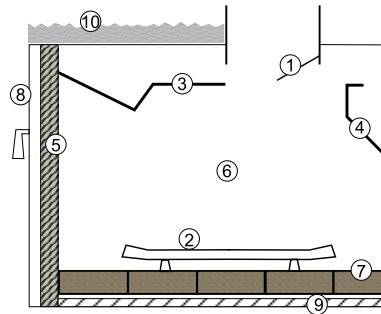

CAUTION:

Firebox floor removal is not covered under the appliance safety standard (ANSI Z21.88, CSA 2.33) used in the safety certification of this appliance. The Intertek safety certification does not apply to this method of installation. Before installing the appliance using this method, contact the Authority Having Jurisdiction to determine if this installation is acceptable in your area. The sheet metal base of the fireplace must be left in place and a minimum 1/2" cement board sheet placed under the entire length and width of the appliance.

If the factory-built fireplace has no gas access hole(s) provided, an access hole of 1.5 inch (37.5 mm) or less may be drilled through the lower sides or bottom of the firebox in a proper workmanship like manner. This access hole must be plugged with non-combustible insulation after the gas supply line has been installed.

General Safety Information

- 1) The appliance installation must conform with local codes or in the absence of local codes, with CSA B149.1 (in Canada) or the National Fuel Gas Code ANSI Z223.1 in the U.S.A. This appliance should be installed by a qualified gas fitter technician only.
- 2) **Installation and repair should be done by a qualified service person.**
- 3) The appliance should be inspected before use and at least annually by a professional service person. More frequent cleaning may be required due to excessive lint from carpeting, bedding material, animal hair, etc. It is imperative that control compartments, burners and circulating air passageways of the appliance be kept clean.
- 4) See general construction and assembly instructions. This appliance may only be installed in a vented, noncombustible fireplace.
- 5) This appliance is listed for bedroom installations when used with a listed Millivolt Thermostat. Some areas may have further requirements, check local codes before installation.
- 6) Always connect this insert to a vent system venting to the outside of the building envelope. Never vent to another room or inside a building. Make sure that the vent is properly sized and is of adequate height to provide the proper draft.
- 7) Inspect the venting system annually for blockage and any signs of deterioration.
- 8) Any glass removed for servicing must be replaced prior to operating the appliance.
- 9) To prevent injury, do not allow anyone who is unfamiliar with the operation to use the fireplace.
- 10) This appliance cannot be operated without brick or enamel panels in place.
- 11) Due to high temperatures, the appliance should be located out of high traffic areas and away from furniture and draperies. Children and adults should be alerted to the hazards of high surface temperatures, especially the fireplace glass and gold trims, and should stay away to avoid burns or clothing ignition. Young children should be carefully supervised when they are in the same room as the appliance. Clothing or other flammable material should not be placed on or near the appliance.

installation

INSTALLATION CHECKLIST

Before installing vent system ensure that the damper plate is open and secure to prevent the damper plate from falling down and crushing the liner.

The Regency Gas Insert is installed as listed.

- 1) Check all clearances to combustibles, (Refer to sections "Minimum Fireplace Dimensions and Clearances to Combustibles")
- 2) Make the gas connection. (Refer to section "Gas Connection")
- 3) Install the two 3" flue liners (intake and exhaust) to the sliding connector plate. (Refer to section "Flue Liner Installation.")
- 4) Slide the unit half way into the fireplace.
- 5) Pull the vent connector plate through the tapered brackets and fasten to the front plate. Refer to section "Flue Liner Installation."
- 6) Slide the unit fully into the fireplace. Level if necessary.
- 7) Hook up 120 volt AC power cord into a suitable receptacle. Optional: Install 4 batteries in receiver. Batteries only serve as back up if power is lost within the home.
- 8) Test gas pressure (Refer to section "Gas Pipe Pressure Testing"). Check aeration system (Refer to section "Gas Insert Aeration System").
- 9) Install standard and optional features. Refer to the following sections:
 - a. Brick, Steel or Enamel Panels (must be installed)
 - b. Log Set
 - c. Glass Crystals
 - d. Spa stones
 - e. Vignette Faceplate
 - f. 4 sided Vignette Faceplate
 - g. Backing Plate
 - h. Inlay
 - i. Spacer
 - j. Hearth Trim
- 10) **Final check:** Before leaving this unit with the customer, the installer must ensure that the appliance is firing correctly. This includes:
 - a) Clocking the appliance to ensure the correct firing rate.
 - b) Adjusting the primary air, if required, to ensure that the flame does not carbon. See "Gas Insert Aeration System" section.
 - c) Ensuring that the appliance is venting correctly.

MATERIALS REQUIRED

A 120 Volt AC power cord is hooked up to operate the fan and operate the gas valve when batteries are not installed in the receiver. Plug the 3 wire cord into a suitable receptacle. **Do not cut the ground terminal off under any circumstances.** When connected with 120 volts, the appliance must be electrically grounded in accordance with local codes, current version of CSA C22.1 (in Canada) or in the absence of local codes, with the National Electrical Code ANSI/NFPA 70-1987.

MINIMUM FIREPLACE DIMENSIONS

The minimum fireplace clearances & dimensions for the Regency gas insert are shown in the following diagrams:

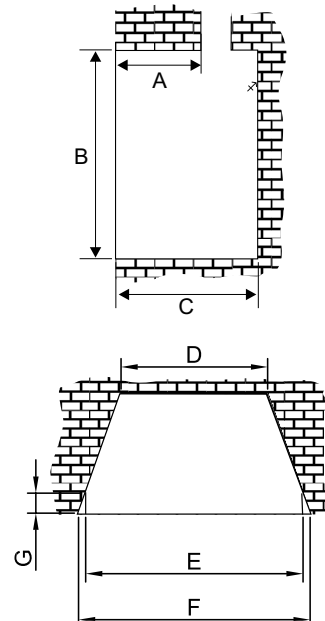

	Max Lintel Bar Depth A	Height B	Depth C	Width (rear) D	Width (front) E	Width F	Front Depth To Taper G
Vignette Faceplate	12.25"	20"	18"	22"	30"	35-5/8"	4-3/8"
Vignette Faceplate w/Spacer	10"	20"	15.75"	22"	30"	31-1/4"	2-1/8"
Arched Faceplate	14"	21-1/2"	21-1/8"	22"	30-1/2"	37"	5-3/8"
Arched Faceplate w/Spacer	12.5"	20"	17.5"	22"	30"	36-1/4"	4"

MINIMUM CLEARANCES TO COMBUSTIBLES

The clearances listed below are Minimum distances unless otherwise stated:

A major cause of fires is failure to maintain required clearances (air space) to combustible materials. It is of the greatest importance that this decorative gas appliance be installed only in accordance with these instructions.

Clearance:	Dimension	Measured From:
A: Sides	8" / 203mm	***From inside edge of faceplate / doors
B: Ceiling	60" / 1524mm	From Base of Unit
C: Mantel (Min. Height)	*32" / 813mm 35" / 889mm	From Base of Unit From Base of Unit
D:Min. Hearth Depth	14" / 356mm	
E: Min. Hearth Length	40"/ 1016mm	
G: Max. Mantel Depth	0 -12" / 305mm	@ 44" (1118mm) from bottom of unit
K: Min. Alcove Width	54" / 1372mm	
L: Max. Alcove Depth	36" / 914mm	
M: Mantel Deflector	3-1/2" / 89mm	

NOTE: 40" (1016 mm) wide x 14" (356mm) deep hearth is required, unless the unit is raised 6" (152 mm) off the floor surface.
 *An optional 3-1/2" deflector, reduces the mantel height to 32" from bottom of unit @ 1" depth.
(J): *Measured from inside edge of faceplate/doors - Reference only: 27-9/16" (700mm)**

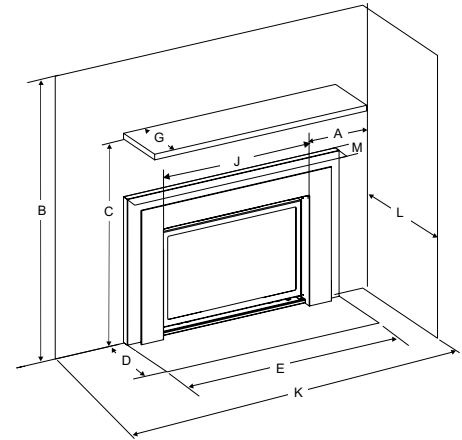

Diagram 1

MANTEL CLEARANCES WITHOUT DEFLECTOR

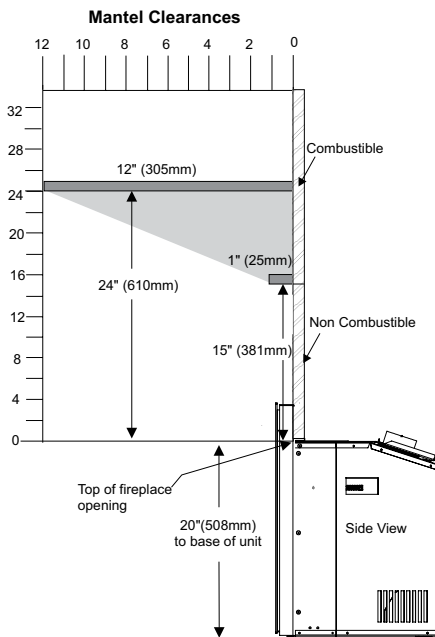

Diagram 2

MANTEL CLEARANCES WITH 3-1/2" DEFLECTOR

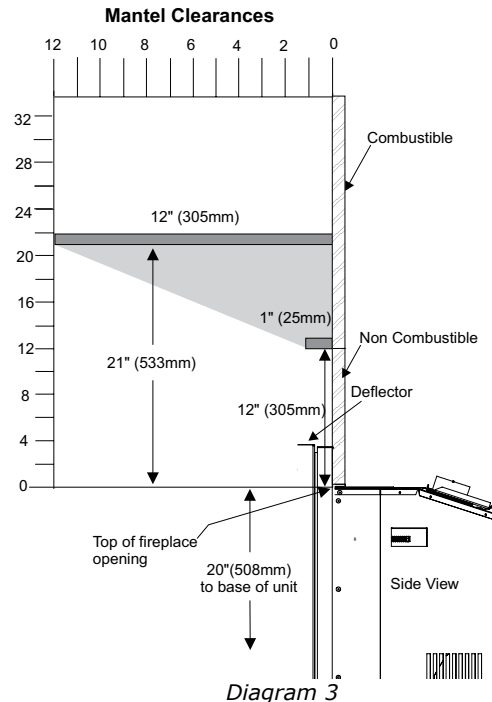

Diagram 3

WARNING
 Although this appliance passes safety certification, the hearth in front of the fireplace becomes very hot when the fireplace heats. Do not use the hearth as a seat or shelf.

Note: A 3-1/2" mantel deflector to reduce mantel height to 32" from bottom of unit @ 1" depth.

A non-combustible mantel may be installed at a lower height if the framing is made of metal studs covered with a non-combustible board. The non-combustible mantel when installed at a lower overall height may not be lower than 6 inches from the top of the fireplace opening.

Note: All material used must be completely non-combustible.

installation

GAS CONNECTION

GAS CONNECTION WARNING:
Only persons licensed to work with gas piping may make the necessary gas connections to this appliance.

- 1) If the appliance is to be installed into an existing chimney system, thoroughly clean the masonry or factory built fireplace.
- 2) The appliance is provided with an opening on the left hand side of the control compartment. A 3/8" NPT gas supply pipe must be brought near this inlet hole.
- 3) Locate the center point where the vent will pass through the chimney above the appliance. Move the appliance into the exact location where it is to be installed. Ensure that the Insert is level.
- 4) Do not cut any sheet-metal parts of the fireplace, in which the gas fireplace insert is to be installed.
- 5) If the factory-built fireplace has no gas access hole(s) provided, an access hole of 1-1/2" (37.5mm) or less may be drilled through the lower sides or bottom of the firebox in a proper workmanship like manner. This access hole must be plugged with a non-combustible insulation after the gas supply line has been installed.

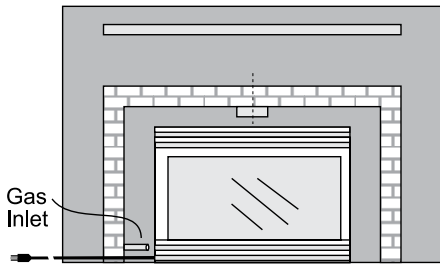

VENTING

THE APPLIANCE MUST NOT BE CONNECTED TO A CHIMNEY FLUE SERVING A SEPARATE SOLID FUEL BURNING APPLIANCE.

This appliance is designed to be attached to two 3" (76mm) co-linear aluminium flex running the full length of the chimney. The flue length must be a minimum length of 8' (2.44m) and a maximum of 35' (10.7m). See chart for minimum distances from roof. Periodically check that the vent is unrestricted.

Masonry chimneys may take various contours which the flexible liner will accommodate. However, **keep the flexible liner as straight as possible**, avoid unnecessary bending.

The Air Intake pipe must be attached to the inlet air collar of the termination cap.

Part #	Description
948-305	3" Flex - 35 ft.
946-529	Co-linear DV Vertical Termination Cap

IMPORTANT: Only the listed termination caps/flex liner noted below can be used. This appliance was tested and certified as a complete system with the noted termination caps and flex liner. Use of termination caps or flex liners not listed in this manual will void the warranty and certification of this appliance. It is also important not to enclose the termination cap inside of a masonry chimney rain cap, or similar. The termination must be exposed on all 4 sides and above to exhaust, and to draw air into the firebox.

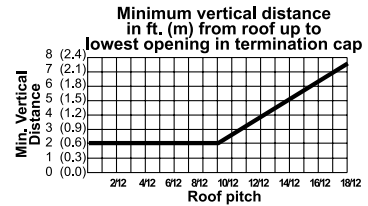

Gas & Electrical Connections

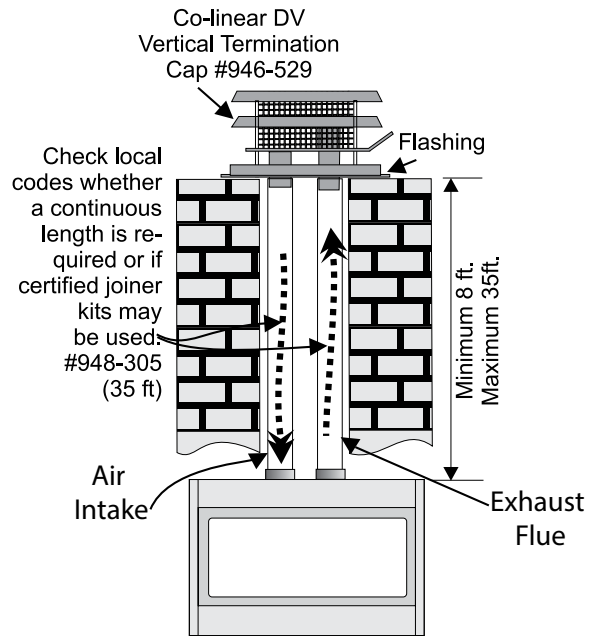

Alternate Approved Caps

- 46DVA-VC Vertical Termination Cap
- 46DVA-VCH High Wind Cap
- 46DVA-GK 3" Co-linear Adaptor with flashing

In areas of consistently high winds, we recommend using the Simpson Dura-Vent System (46DVA-GK adaptor and 46DVA-VCH high-wind cap). The Air Intake pipe must be attached to the inlet air collar of the termination cap.

FLUE / VENT INSTALLATION

Connecting the Vent Liners



NOTE: Flue Plate Connector Gasket must not be damaged or removed. Care must be taken to ensure that this gasket remains intact to prevent flue leakage.

- 1) Detach the Flue Connector Plate from the unit by removing the Connector Plate Screws and sliding the Flue Connector Plate forward and off the unit.

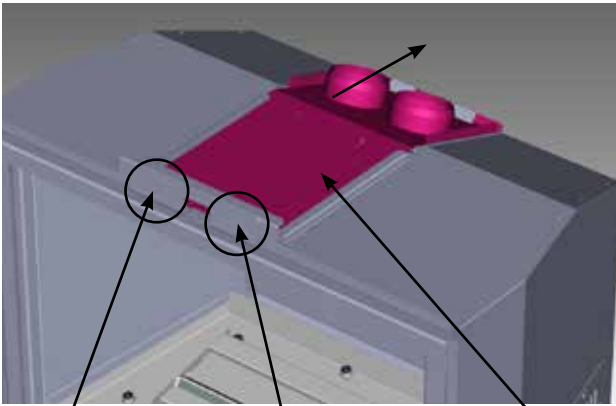

Connector plate screws

Flue Connector Plate

- 2) Attach the Flue Liners onto the Flue Connector Plate using non RTV type sealant, then fasten with 3 screws. See the section in this manual on Venting installation.
- 3) Position the unit in front of the fireplace opening, start the Flue Connector Plate into the Flue Connector Plate Guides.

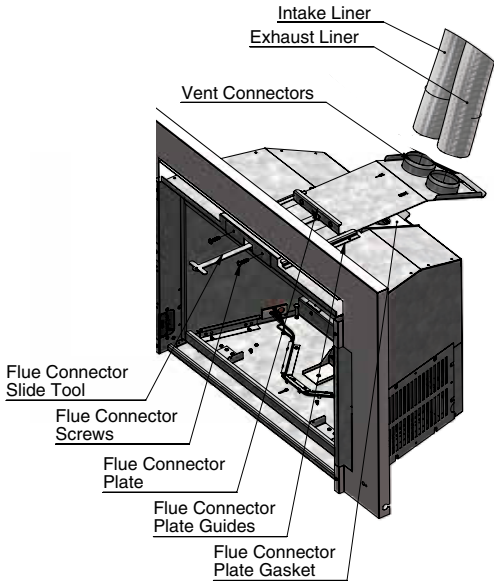

- 4) Use the Flue Connector Slide Tool to slowly pull the Flue Connector Plate forward as you move the Insert rearward into the Fireplace Chase.

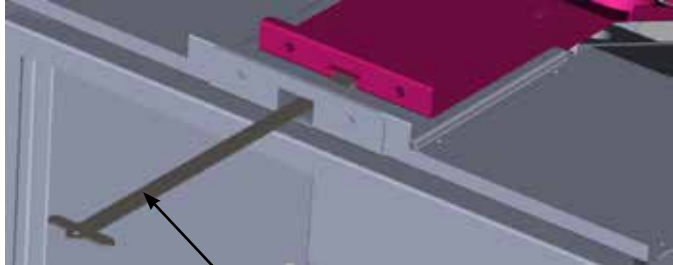

Flue Connector Slide Tool

- 5) When the Flue Connector Plate is close to the front of the unit, engage the Flue Connector Screws and carefully tighten the Flue Connector Plate the final amount.

** Make sure the Rear Tabs connect into their respective slots in the Flue Connector Plate. Failure to do so will result in flue gas leakage and degrade the operation of the unit ** (See diagram below of location.)

The Flue connection is complete when the Flue Connector Plate is fully forward and the Rear Tabs are fully engaged.

- 6) Remove the Flue Connector Tool and store for future use.

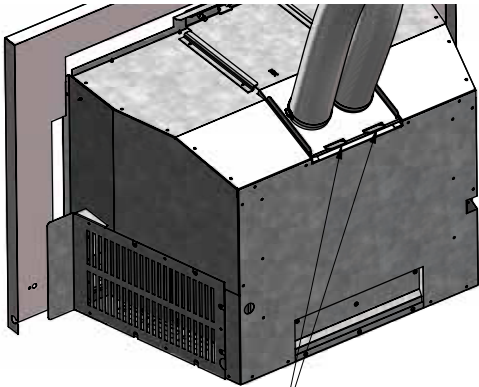

Rear tabs fully engaged

Properly installed Flue Connector Plate

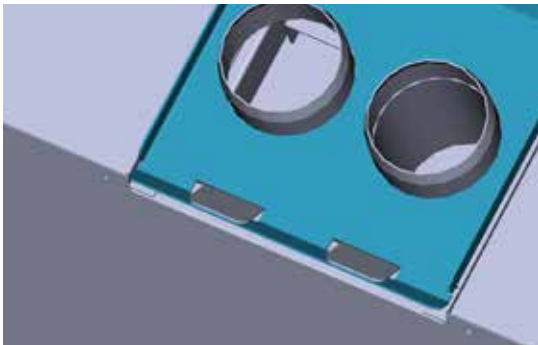

WARNING: Failure to position the parts in accordance with these diagrams or failure to use only parts specifically approved with this appliance may result in property damage or personal injury.

installation

LEVELLING LEG ADJUSTMENT

The LRI4E / HRI4E inserts are equipped with 2 rear levelling legs that are accessible while the appliance is in its final installation position. The unit can be adjusted up to 5/16" (16mm).

Remove left and right side filler pieces. The rear levelling bolts are located in the back corners of the firebox and can be adjusted using a 7/16" wrench. Rotate the bolts clockwise to raise the rear of the firebox.

When the appliance is in position, adjust the bolts to level the appliance, making sure that the appliance is also level and is sitting on the 2 bolts to prevent rocking.

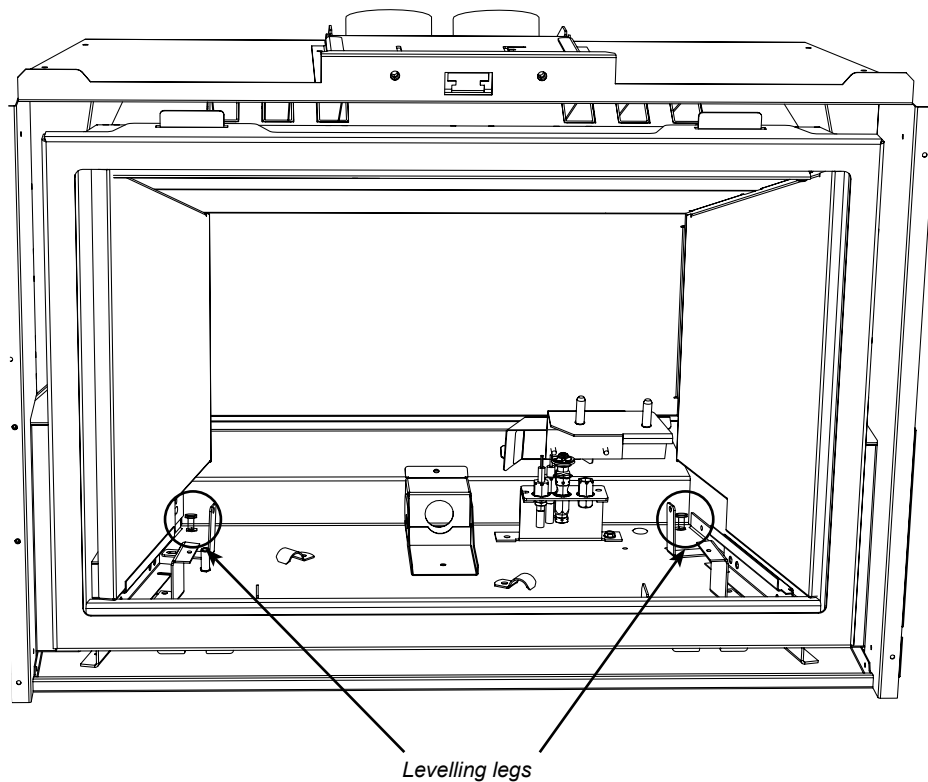

AIR SHUTTER ADJUSTMENT

Air Shutters are required to increase or decrease the amount of air that is mixed with the fuel before combustion. This will have an affect on how well the fuel combusts and how the flame appears physically.

Low primary air will leave a taller, yellower flame while higher primary air will leave a lower, bluer flame.

This setting is largely for appearance, however, not enough primary air may lead to carboning, sooting or a flame that reaches the top of the firebox. Situations that may require more primary air are; units that are burning propane, units installed at higher elevations or units that are run on high most of the time.

The LRI4E / HRI4E are equipped with an air shutter that is accessible from outside the firebox and can be adjusted during operation.

Aeration adjustments should only be made after the unit has been on for 30 minutes to 1 hour.

Slide the Air Shutter Lever towards you to increase the primary air setting.

Slide the Air Shutter away from you to decrease the primary air setting. Below you will see a chart showing the minimum primary air settings.

These are set from the factory, but due to fuel conversions or installation conditions, the air setting may need to be adjusted.

Unit	Fuel Type	Min. Air Setting
LRI4E	NG	3/16" (5mm)
LRI4E	LP	1/4" (6mm)
HRI4E	NG	3/16" (5mm)
HRI4E	LP	1/4" (6mm)
HRI4E w/optional driftwood logs	NG	Fully Open

CAUTION: Carbon will be produced if air shutter is closed too much.

Note: any damage due to carboning resulting from improperly setting the aeration controls is NOT covered under warranty.

Note: Aeration Adjustment should only be performed by an authorized Regency Installer at the time of installation or service.

Note: The HRI4E with optional driftwood logs is only approved for use with NG. This is not approved when using propane.

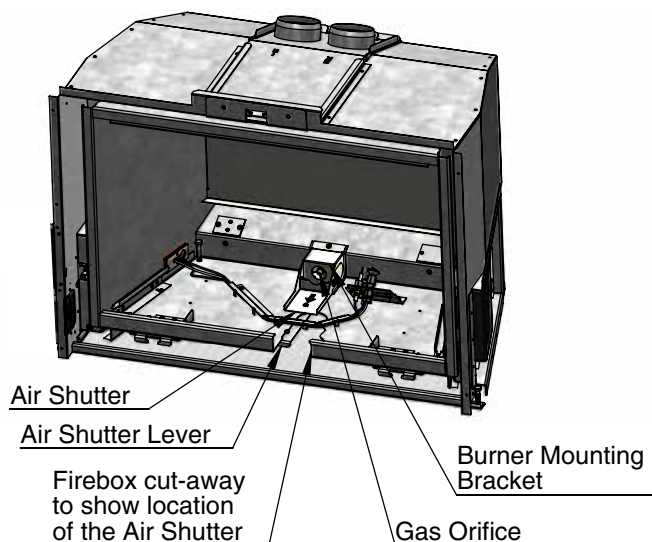

- 1) Slide the Air Shutter Lever towards you to increase the primary air setting.
- 2) Slide the Air Shutter away from you to decrease the primary air setting. Below you will see a chart showing the minimum primary air settings.

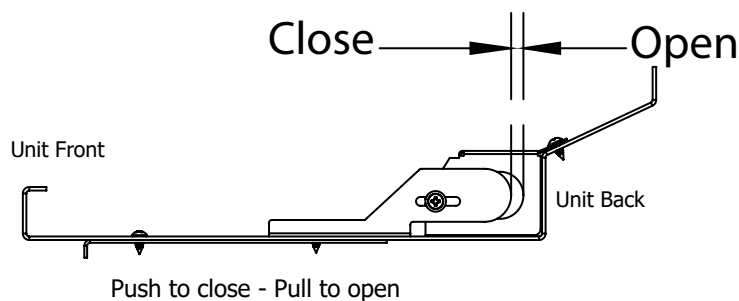

installation

LRI4E-NG11 / HRI4E-NG11 SYSTEM DATA	
Min. Supply Pressure	5" WC (1.25 kpa)
Max. Manifold Pressure	3.5" WC (0.87 kpa)
Low Setting Man. Pressure	1.6" WC (0.41 kpa)
Orifice Size	#37 DMS
Maximum Input	31,000 Btu/h (9.09 kW)
Minimum Input	22,000 Btu/h (6.45 kW)

LRI4E-LP11 / HRI4E-LP11 SYSTEM DATA	
Min. Supply Pressure	11" WC (2.73 kpa)
Max. Manifold Pressure	10" WC (2.49 kpa)
Low Setting Man. Pressure	6.4" WC (1.59 kpa)
Orifice Size	#53 DMS
Maximum Input	31,000 Btu/h (9.09 kW)
Minimum Input	26,000 Btu/h (7.62 kW)

HIGH ELEVATION

This unit is approved for altitude 0 to 4500 ft. (CSA 2.17).

GAS LINE INSTALLATION

Since some municipalities have additional local codes it is always best to consult with your local authorities and the CSA B149.1 installation code.

For US installations follow local codes and/or the current National Fuel Gas Code, ANSI Z223.1.

When using copper or flex connectors use only approved fittings. Always provide a union so that gas lines can be easily disconnected for servicing. Flare nuts for copper lines and flex connectors are usually considered to meet this requirement.

NOTE: A shutoff / dante valve should be supplied in or near the unit (or as per local codes) for ease of servicing this appliance.

IMPORTANT: Always check for gas leaks with a soap and water solution or gas leak detector. Do not use open flame for leak testing.

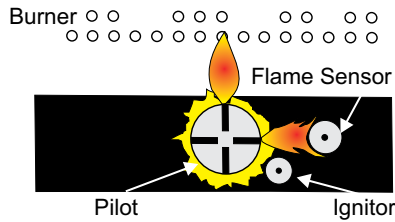

Note: If you have an incorrect flame pattern, contact your Regency® dealer for further instructions.

Incorrect flame pattern will have small, probably yellow flames, not coming into proper contact with the rear burner or flame sensor.

GAS PIPE PRESSURE TESTING

The appliance must be isolated from the gas supply piping system by closing its individual manual shut-off valve during any pressure testing of the gas supply piping system at test pressures equal to or less than 1/2 psig. (3.45 kPa). Disconnect piping from valve at pressures over 1/2 psig.

The manifold pressure is controlled by a regulator built into the gas control, and should be checked at the pressure test point.

Note: To properly check gas pressure, both inlet and manifold pressures should be checked using the valve pressure ports on the valve.

- 1) Make sure the valve is in the "OFF" position.
- 2) Loosen the "IN" and/or "OUT" pressure tap(s), turning counterclockwise with a 1/8" wide flat screwdriver.
- 3) Attach manometer to "IN" and/or "OUT" pressure tap(s) using a 5/16" ID hose.
- 4) Light the pilot and turn the valve to "ON" position.
- 5) The pressure check should be carried out with the unit burning and the setting should be within the limits specified on the safety label.
- 6) When finished reading manometer, turn off the gas valve, disconnect the hose and tighten the screw (clockwise) with a 1/8" flat screwdriver. **Note: Screw should be snug, but do not over tighten.**

885 S.I.T. VALVE DESCRIPTION

- 1) 6 Stage flame adjustment
- 2) Pilot adjustment
- 3) Inlet Pressure Tap
- 4) Outlet Pressure Tap
- 5) Pilot Outlet
- 6) Main Gas Outlet
- 7) Main Gas Inlet

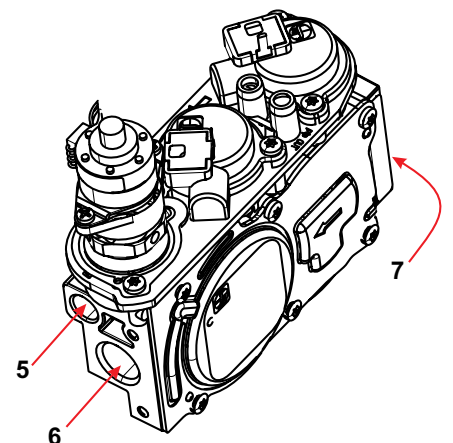
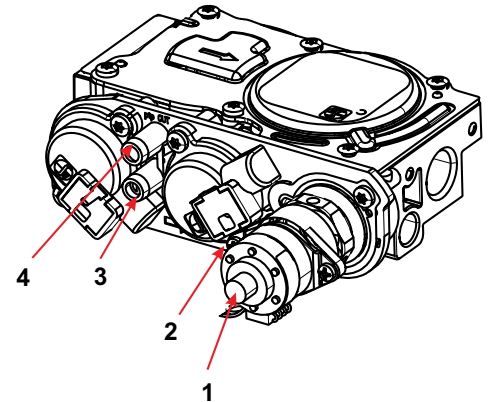

PROFLAME REMOTE SYSTEM GTMF WITH FAN (LRI4E / HRI4E)

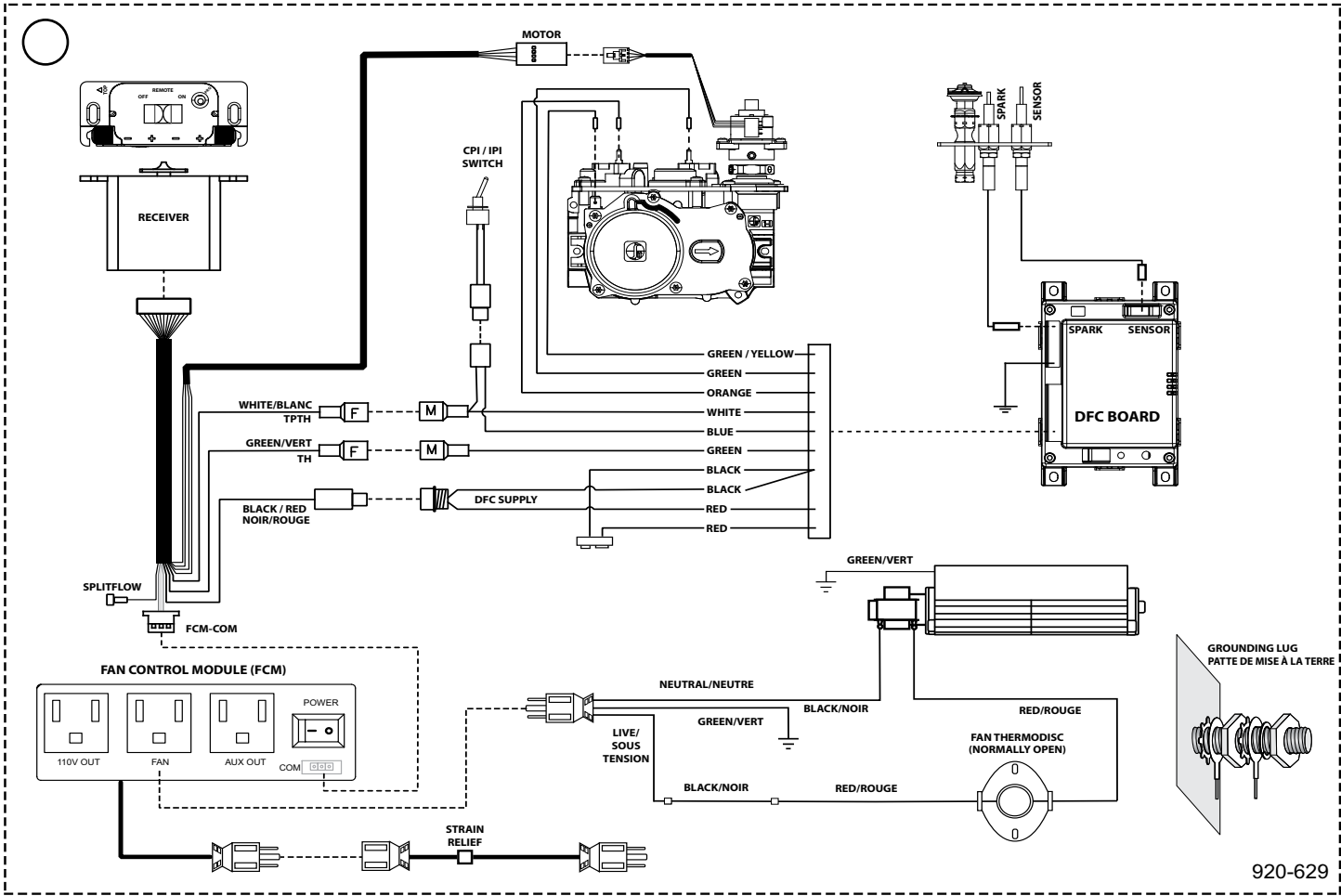

Proflame Remote Operation



Proflame Remote Battery Change

GTMF REMOTE SYSTEM - IMPORTANT: The 120V fan control module serves as the power source for this unit. The AA batteries in the receiver only serve as a backup in case 120 volt power lost within the home.

CAUTION: Label all wires prior to disconnection when servicing controls. Wiring errors can cause improper and dangerous operation.

Caution: Ensure that the wires do not touch any hot surfaces and are away from sharp edges.

installation

OPTIONAL WALL THERMOSTAT INSTALLATION

This installation must be completed during initial install prior to the faceplate being installed.

A wall thermostat may be installed if desired.

1) Run wires from thermostat into the unit.

2) Remove the green wire marked (TH) at the white connector-shown below. The noted wires will be located near the gas valve.

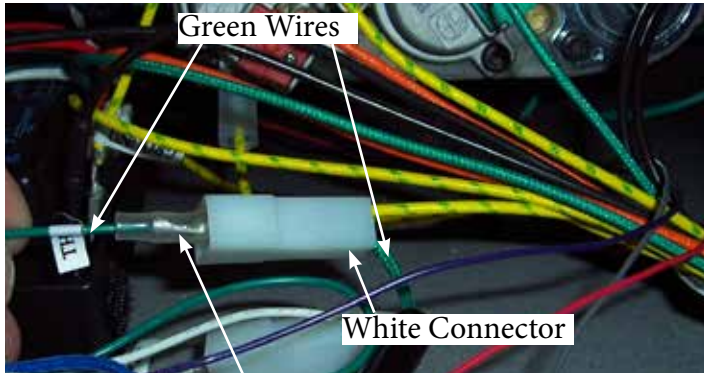

CAUTION
Do not wire
Thermostat wires
to 120V wire.

3) Connect one thermostat lead to female connector, using male spade connector - see picture below.

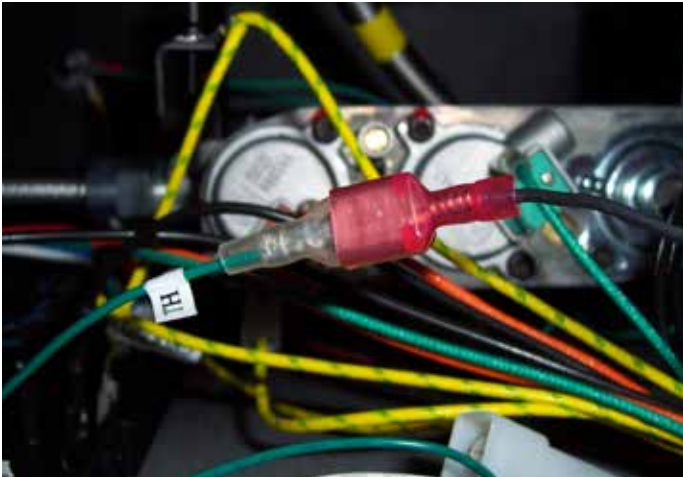

4) Connect the other thermostat lead to male connector disconnected from Step 1 using a female spade connector - see picture below.



When complete turn remote receiver to the ON position.
Unit will now operate using the wall thermostat.



NOTE: When the remote receiver is set to ON position, the remote control transmitter and all of its features are now disabled.

CONVERSION FROM NG TO LP

LRI4E /HRI4E using SIT 885 NOVA Gas Valve

**THIS CONVERSION MUST BE DONE BY A QUALIFIED GAS FITTER
IF IN DOUBT DO NOT DO THIS CONVERSION!**

WARNING
This conversion kit shall be installed by a qualified service agency in accordance with the manufacturer's instructions and all applicable codes and requirements of the authority having jurisdiction. If these instructions is not followed exactly, a fire, explosion or production of carbon monoxide may result causing property damage, personal injury or loss of life. The qualified service agency is responsible for the proper installation of this kit. The installation is not proper and complete until the operation of the converted appliance is checked as specified in the manufacturer's instructions supplied with the kit.

Conversion Kit 399-977 includes:		
1	911-011	Stepper Motor LP for 885 SIT
1	904-947	Orifice #53
1	910-037	Pilot Orifice #30
1	918-590	Decal - Conversion to LP
1	908-528	Label Propane
1	904-529	5/32" long Allen Key

Before you begin:

**Shut off the gas supply to the unit.
Disconnect all electrical supply to the unit.**

Always let the appliance cool to room temperature before servicing.

- 1) Remove the left side control cover.

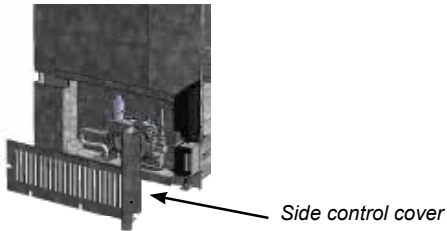

The valve in the LRI4E is attached using 2 screws and 2 hooks located below the valve. Loosening the screws part way and lift the valve to disengage the hooks.
The valve will then hinge outward allowing access to the components and pressure taps located on the top of the valve without completely removing the valve.



- 2) Loosen both screws at the top of the valve about 1/2 way out. Lift the valve body and lean outward. The Valve Brackets will rest open as shown on the right.



- 3) Disconnect the Cable coming from the Pressure Regulator Motor.



- 4) Remove and discard 2 Pressure regulator screws A (T20 or slot), Pressure Regulator B, Spring and Diaphragm C.
- 5) Ensure the rubber gasket, which is prefitted as part of the Assembly, is properly positioned. Install the new Pressure Regulator using the 2x M4 x .7 screws supplied. Tighten the screws to 25lb-in. In the event that the screw threads are cross threaded or stripped, replace the valve assembly.

Install the enclosed propane identification label to the valve body where it can be easily seen.

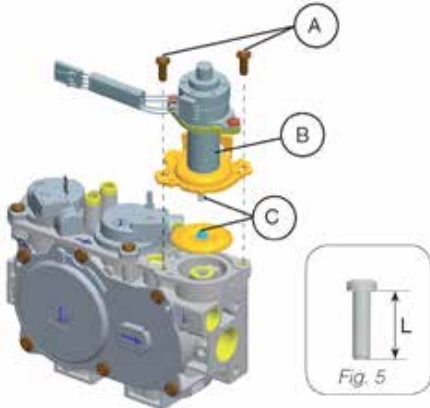

installation

- 6) Re-attach the Pressure Regulator wire, and re-situate the Gas Valve, secure the screws that fasten the Gas Valve Mounting Brackets.
- 7) Remove burner (see burner removal section in manual).
- 8) Using a 3/8" socket wrench, loosen and remove the main gas orifice. Replace with the LP gas orifice. Confirm the orifice size marked on the Orifice with the Rating Label on the appliance



- 9) Remove pilot retainer clip with pliers and pull off the pilot cap to expose the pilot orifice.



Pilot retainer clip



- 10) Unscrew the pilot orifice with the allen key; then replace with the LPG pilot orifice and the pilot cap, provided in the kit.

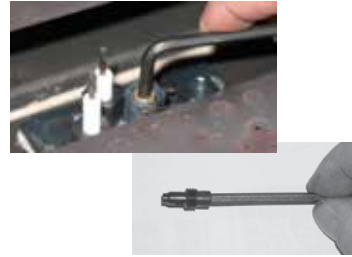

- 11) Ensure the pilot light is in the correct orientation to the Burner. Reconnect the gas and electrical supply to the appliance. Start the appliance. (see section on Lighting Instructions) Ensure that pilot and burner ignition is completed without delay. Check both your inlet and outlet pressures at full load. With a soapy solution, leak test the entire system. Verify both the correct flame and pilot appearance.
- 12) See Gas Pipe Pressure Testing in manual.
- 13) Adjust aerations settings - see Air Shutter Adjustment section in the manual.

Installer Notice:
These instructions must be left with the appliance.

MEDIA INSTALLATION

Spread the Media evenly over the burner. Ensure installed media does not overlap excessively as this will affect the flame pattern.

IMPORTANT NOTE:

Only the supplied approved Media is to be used with these fireplaces. Use of any other type of media can alter the unit's performance, any damage caused by the use of any unapproved media will not be covered under warranty.

When using Ceramic Spa/Volcanic Stones **DO NOT** cover burner ports or pilot light that leads to pilot flame.

BURNER PACKAGES			
Unit	Glass Crystals	Fire Beads	Stones - Ceramic Spa Stones / Volcanic Stones / Pebbles
HRI4E	8 lbs [5 lbs burner + 3 lbs firebox]	8 lbs [5 lbs burner + 3 lbs firebox]	7 lbs Glass (burner) + 1 package (70 Ceramic Spa Stones) 8 lbs Beads (burner) + 1 package (70 Ceramic Spa Stones) 4 lbs Glass (burner) + 26 Volcanic Stones 8 lbs Beads (burner) + 26 Volcanic Stones 5 lbs Glass (burner) + 3 bags Pebbles (around firebox base)
<p>NOTE: Media is not supplied with the unit. Must purchase separately - see quantities above. Ceramic Spa stone package contains 70 stones.</p>			



Glass Crystals shown on Burner and Firebox Floor



DO NOT block pilot area with glass crystals

OPTIONAL PEBBLES / GLASS CRYSTAL / FIREBEAD INSTALLATION FOR FIREBOX BASE (AROUND BURNER)

Firebox (Around Burner) Packages

Unit Glass Crystals, firebeads & Pebbles

HRI4E 5 lbs glass crystals, firebeads on burner + 3 bags pebbles (around firebox base)

There are 3 optional packages to choose from to cover the firebox base:

- 1) Natural River Pebbles
- 2) Glass Crystals (3 colors available)
- 3) Firebeads (4 colors available)

Spread the pebbles / crystals/firebeads evenly on the exposed base of the firebox. Pebbles are NOT to be placed anywhere on the burner or over top of the Glass Crystals, firebeads or optional Stones.



Installing Glass Crystals

IMPORTANT NOTE: Only the supplied and approved pebbles / glass crystals/firebeads are to be used with these fireplaces. Use of any other type of pebbles, glass crystals, firebeads or other material can create a danger and will void the warranty.

CAUTION

DO NOT place ceramic spa stones or volcanic stones over pilot and burner ports.

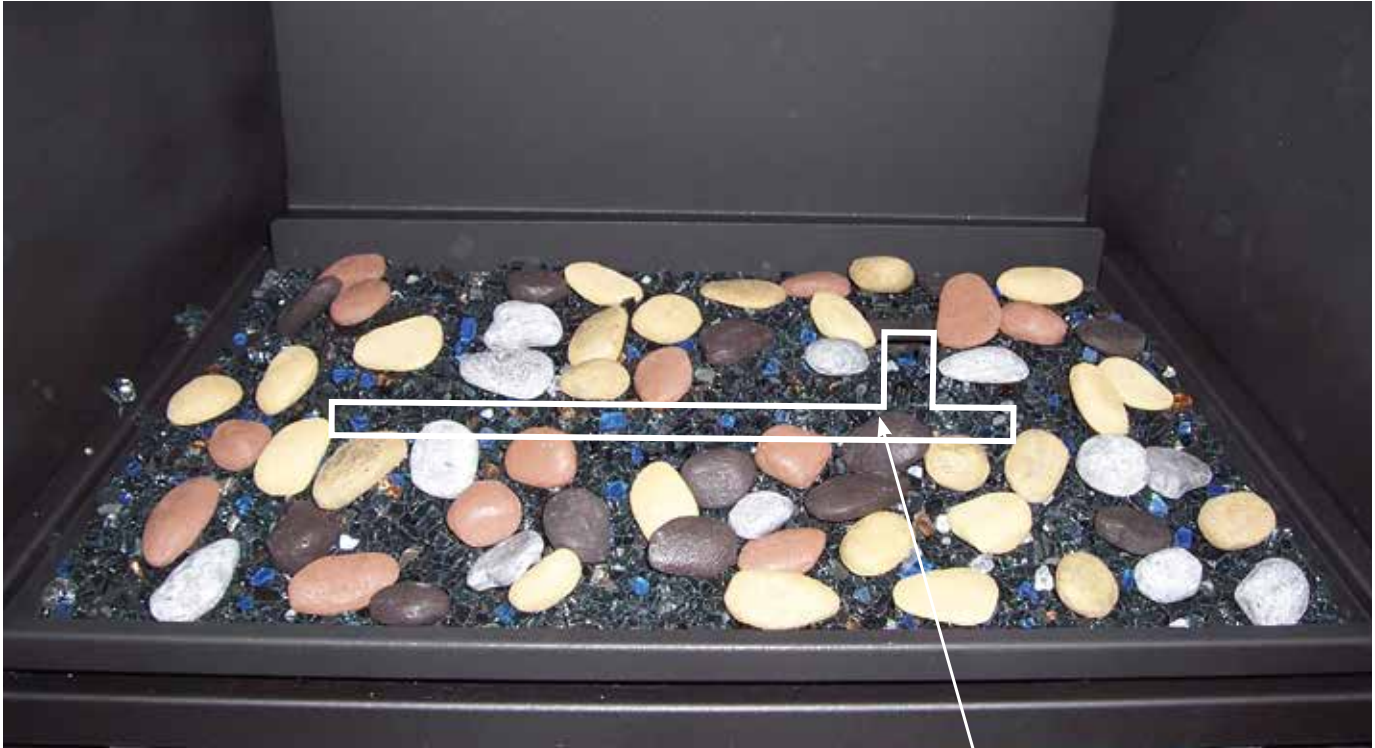

No ceramic spa stones in this area.

Note: When adding volcanic stones ensure that the same criteria is met when installing ceramic spa stones as per above picture. Volcanic stones must also be free and clear of the pilot area and never be placed on burner ports.

HRI4E OPTIONAL LOG SET INSTALLATION

Read the instructions below carefully and refer to the images. If the logs are broken do not use the unit until they are replaced. Broken logs can interfere with pilot operation.

Improper positioning of the logs and glass crystals may create carbon build-up and can alter the unit's performance which is not covered under warranty.

*For Touch Ups: Dark Brown paint is included.

Note: This Log installation is for **NG** units only.

1	Rear Centre Log
2	Centre Right Front Angled Log Piece
3	Right Forked Upright Log
4	Left Angled Upright Log
5	Left Angled Cross Log
6	Right Front Angled Log Piece
7	Centre Left Front Angled Log Piece
	Rear Log Bracket (HRI6E/HRI4E units)
	Pilot shield (HRI4E units only)
	Lava Rock and Embers

Glass/Beads quantities with Log installation	
HRI4E	6 lbs
HRI6E	9 lbs
Note: If glass previously installed - remove 2lbs to equal above quantity.	

Ensure unit is cooled to room temperature and remove glass door.

1. HRI4E Unit only.

Remove burner (see manual for instructions).
Remove existing pilot shield by removing 2 screws.
Install pilot shield provided with Log Set using 2 screws from previous pilot shield. Reinstall burner.

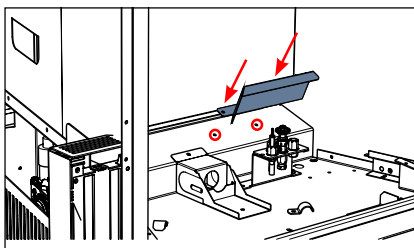

New Pilot Shield - HRI4E Only

Diagram 1

2. Both HRI4E & HRI6E Units:

Sweep glass aside from pilot covers (if already installed) to install Rear Log Bracket. Rest the front edge of the Rear Log Bracket on the back of the burner screen cover and clip the front edge of the rear bracket on to rear of the burner as shown in Diagram 2.

IMPORTANT: After the Rear Log Brackets are installed glass crystals must be reapplied. Glass crystals should not be higher than the bottom of the pilot screen cover as shown in Diagram 3. Pilot area needs to be clear to allow proper ignition as shown in Diagram 3.

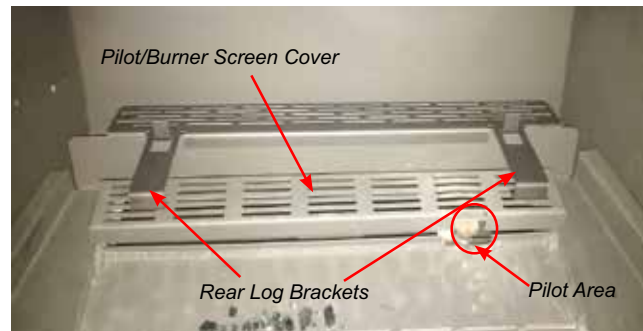
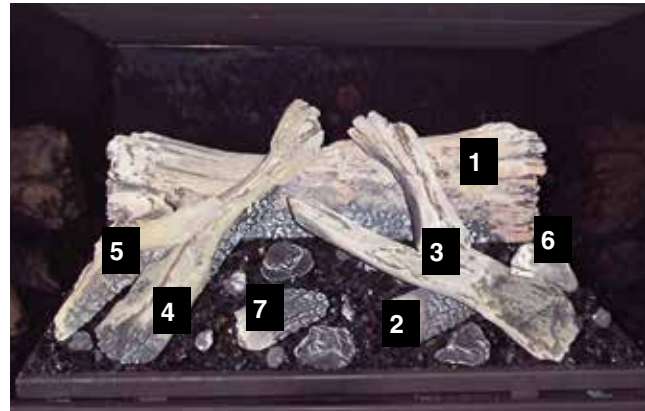

Diagram 2

NOTE: HRI4E shown above. The HRI6 pilot (not shown) is located on the left hand side.

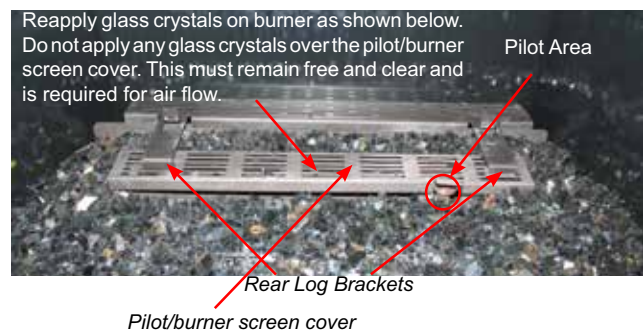

Diagram 3

installation

- Place Log 1 on Rear Log Bracket in front of tabs, ensure Log is centered.



Center Log 1 on bracket

- Place Log 2 on the glass, angled with the non charred point of the Log is approximately 9-1/4" from the right side of the burner tray.

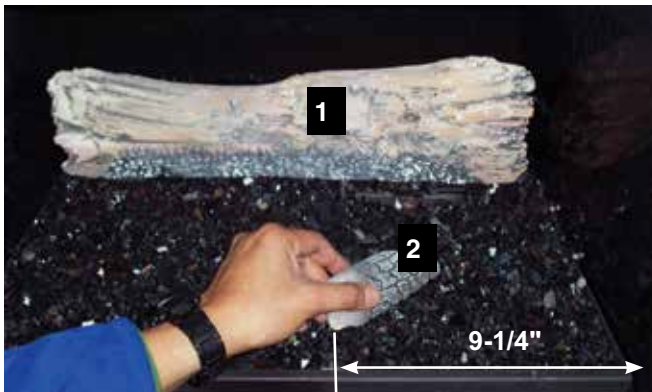

Position Log 2

- Place Log 3, rest on Log 2, match pin locator on Log 3 with landing pin on Log 1. Angle the longest point on Log 3 is approximately 1/4' from the outside edge of the burner tray.



Line up pin locator and pin, Logs 1,3

- Place Log 4, match pin locator on Log 4 with landing pin on Log 1. Angle the longest point on Log 4 is approximately 1/4' from the outside edge of the burner tray.

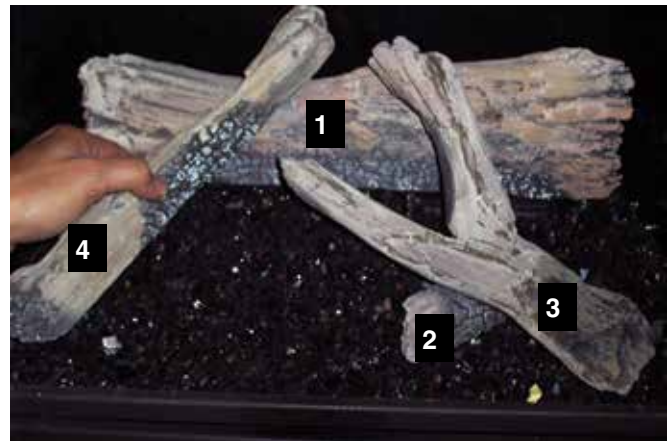

Line up pin locator and pin, Logs 1,4

- Place Log 5 across Log 4, match pin locator on Log 5 with landing pin on Log 4.

Note: there are 2 pin locators on Log 5, lower locator is for HRI4E units and the upper locator is for the HRI6E units.

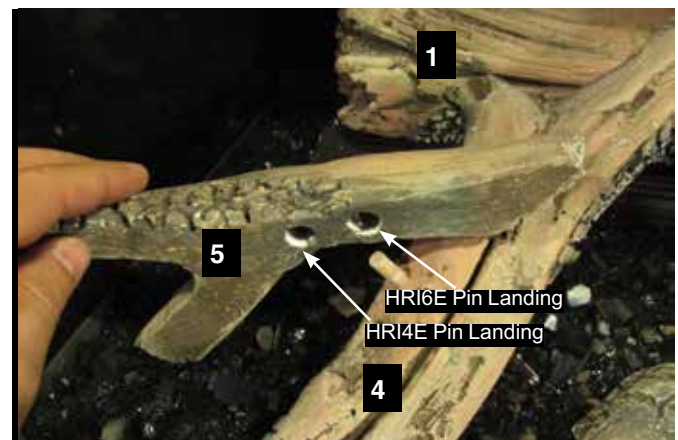

Line up pin locator and pin, Logs 5,4

8. Place Log 6 - rest on Log 3 as shown below.



Position Log 6

9. Place Log 7 on the glass as shown below.



Position Log 7

10. Place embers and Lava rocks on the glass as shown below.

Note: Properly positioned, Logs 3 & 4 should measure 1/4" from their longest point to the outside edge of the burner tray.

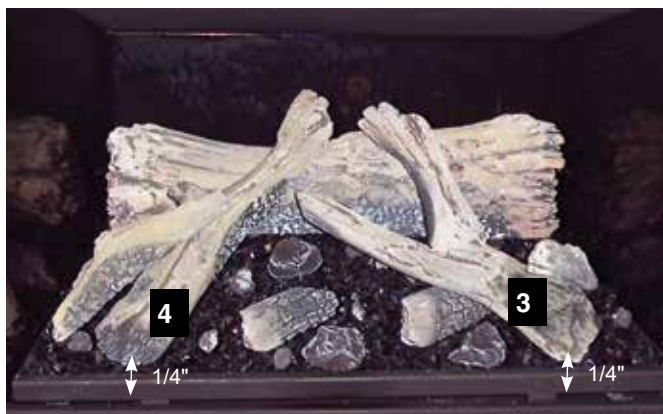

Place Lava Rock and Embers on Glass

11. Reinstall Glass Door.

12. Adjust aeration setting to fully open (manual for detailed instructions)

Note: Logs to be installed in NG units only.

installation

LRI4E LOG SET INSTALLATION

Read the instructions below carefully and refer to the images. If the logs are broken do not use the unit until they are replaced. Broken logs can interfere with pilot operation.

Improper positioning of the logs may create carbon build-up and can alter the unit's performance which is not covered under warranty.

*For Touch Ups: Satin Black paint is included for burner, and Dark Brown Paint is included for log set,

1	Rear Bottom Left Log
2	Right Upright Log
3	Middle Right Log Piece
4	Front Left Log Piece
5	Front Right Log
6	Front Right Angled Log
7	Top Back Log

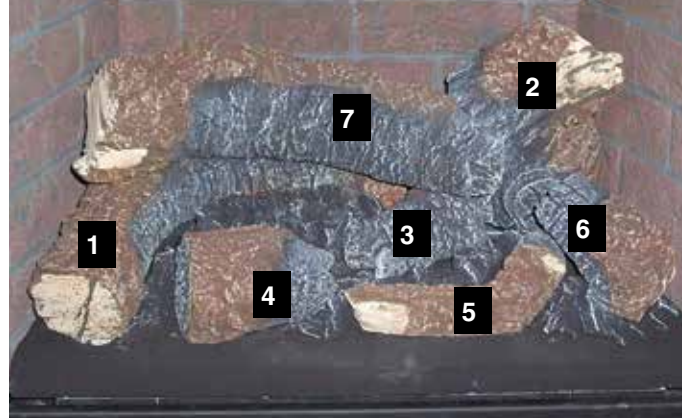

1. Seat Log 1 on the back left side indent in the burner. When Log is seated, grasp both ends of the Log and slide forward until Log 1 is snug against raised portions of burner.



Log 1 location on burner

2. Identify corresponding pin locators on bottom of Log 2 and line up with pins on burner- see below.



Log 2 pin locator, line up with pins on burner

3. Seat Log 3 into indent in burner as shown below.



4. When seated, push Log 3 to the back as far as it will go within indent. to prevent any carboning.

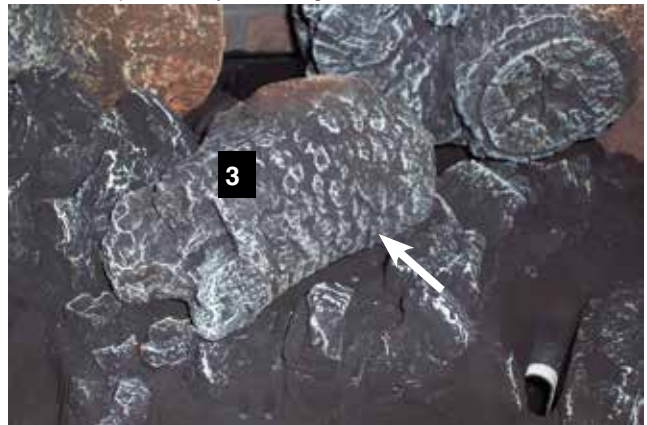

Log 3 push to the back of the indent

5. Seat Log 4 into front, right depression on burner as shown below.

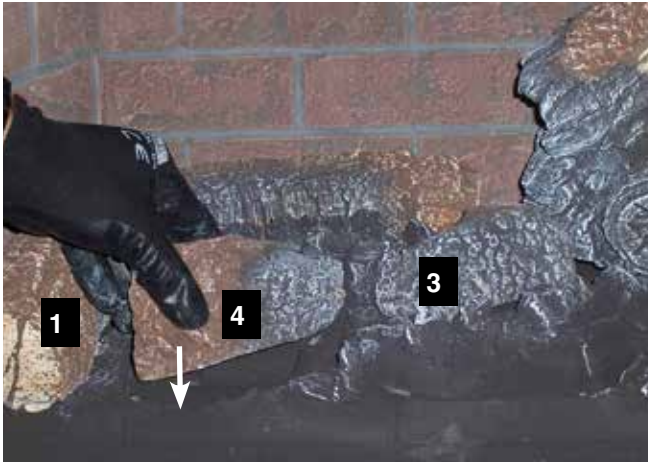

Placement of Log 4

6. Position Log 5 by seating into the indent located at the front of the burner towards the right as shown below.



Location for Log 5

7. Log 6 is positioned in the indent on the far right of the burner in the orientation shown below.



Location for Log 6

8. Line up the pin locator in Log 7 with the pin in Log 1.

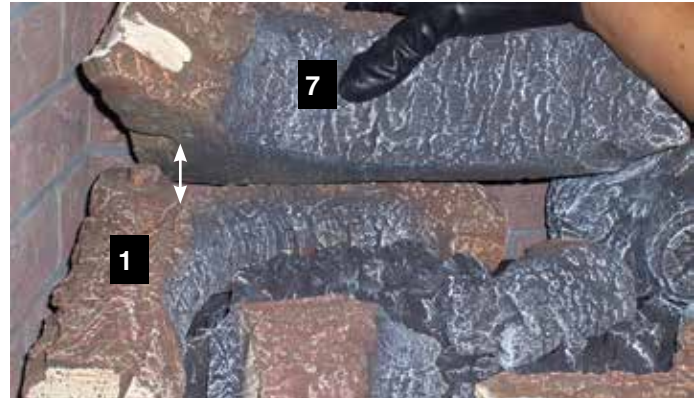

Log 7 pin locator line up with Log 1 pin

9. When Log 7 is seated, manoeuvre it is contacting Log 2.

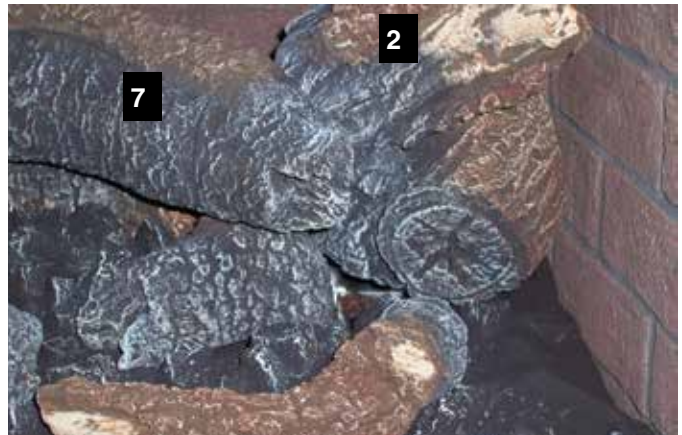

Log 7 and Log 2 should make contact

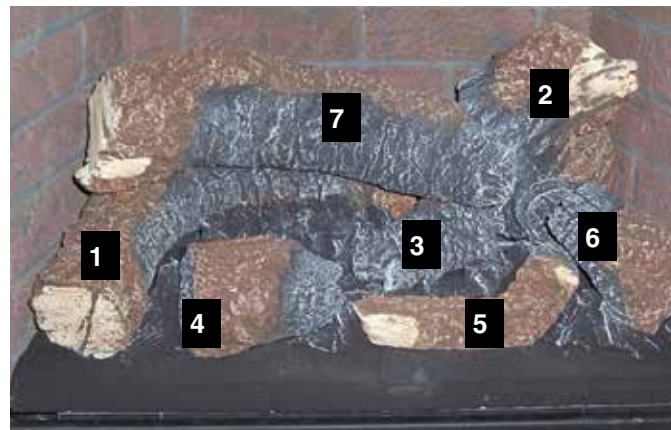

Final Install

installation

STANDING PILOT & HEAT EXCHANGE RETURN/FLUE RESTRICTOR

The LRI4E / HRI4E use a heat exchanger and efficient combustion technology to provide extreme heating efficiencies. The more efficient an appliance becomes, the lower the flue gas temperatures becomes. On start-up, flue temperatures are required to initiate venting action.

Here are some considerations when setting up the LRI4E / HRI4E:

- 1) When operating the unit in temperatures below 50° F, run the pilot in "Standing Pilot" mode, by setting the Surefire™ switch to ON. The switch is located to the bottom left of the Firebox Door.
- 2) Move the switch to the right to run in Standing Pilot mode, to the left to run in Intermittent Pilot (electronic ignition) mode. This will aid in keeping the flue slightly warmer than the outside air, making start up a smoother process.
- 3) When operating the unit in extreme cold climates, or at higher elevations, consider removing the heat exchange return. This component is located in the flue of the firebox, and is designed to increase the operational efficiency of the heat exchange. Removing this component decreases restriction in the venting system. This may aid venting in locations challenged by higher elevations, difficult vent runs, or very cold climates, or operating the unit with a lower heat output to the run in which it is installed.

ADDING THE HEAT EXCHANGE RETURN/FLUE HEAT EXCHANGE RETURN/FLUE RESTRICTOR

NOTE: Only installed at elevations of 35 feet maximum vent run.

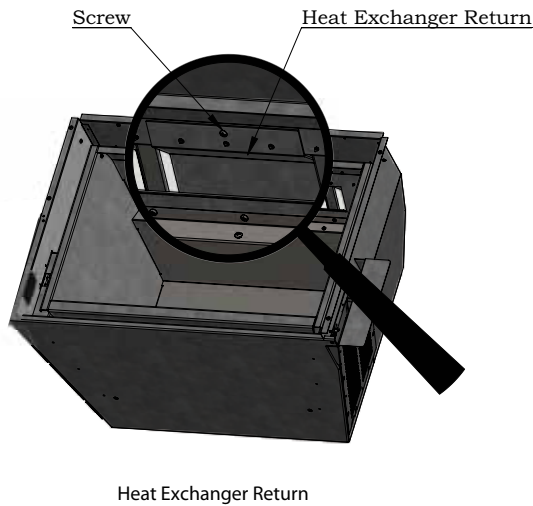

RESTRICTOR

- 1) Remove the brick/steel/enamel panels if they are already installed. Remove one screw in the upper left and upper right of the firebox. If the unit has been previously operated, spray these screws with WD-40. Once the screws have been removed, lower the front edge of the exhaust baffle and pull towards you. There are 3 screws at the rear of the exhaust baffle that help to position the baffle and keep it straight during operation.
- 2) Install the heat exchange return/flue restrictor as shown.
- 3) Reinstall the exhaust baffle.

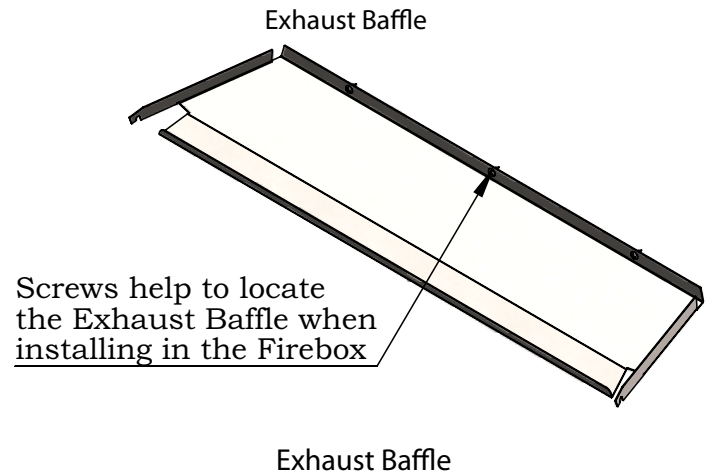
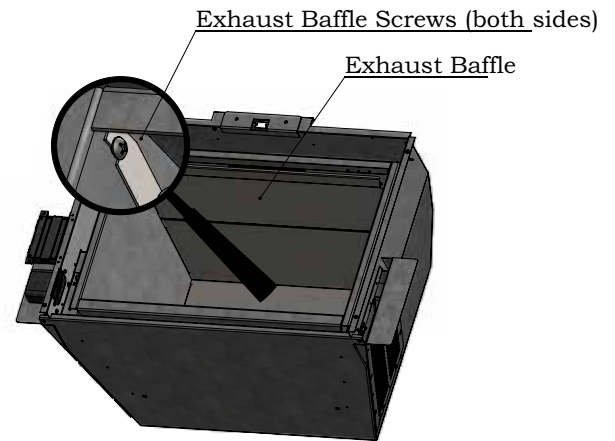

BRICK PANEL INSTALLATION

IMPORTANT: THIS APPLIANCE CANNOT BE OPERATED WITHOUT BRICK OR ENAMEL PANELS INSTALLED.

Brick panels are soft and fragile. Use caution when handling the panels, being careful not to jar them or scratch the painted surfaces.

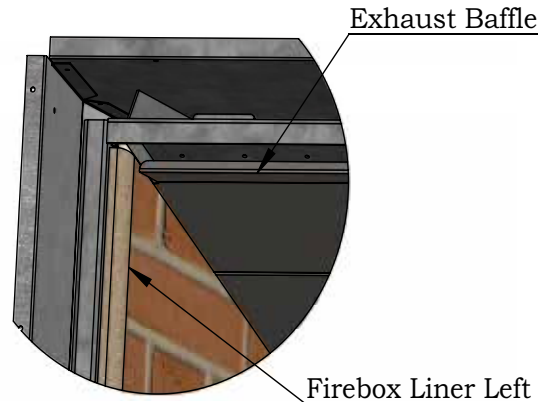
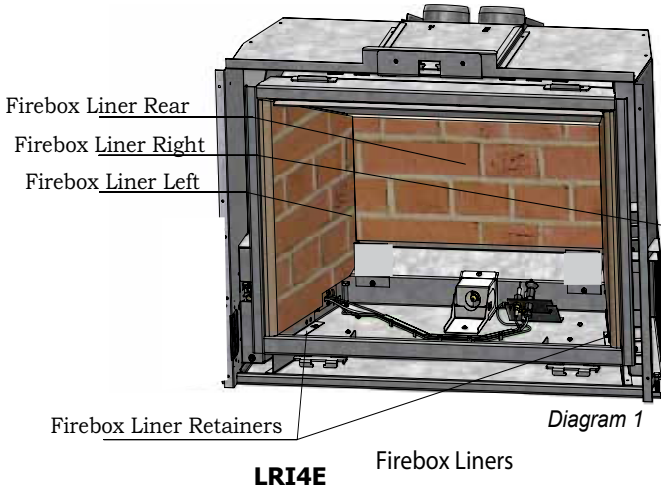

Upper Left of Firebox

5. Once one Firebox Liner Side is installed, you can release the Firebox Liner Rear. The side Liner will hold the rear Liner in place. Install the Firebox Liner Left the same way you installed the Firebox Liner Right. Both side liners should be just slightly back from the front edge of the Firebox.

1. Remove left/right filler sections and discard - see below.



Left /right filler sections



2. Remove the firebox liners from their packaging. Inspect them prior to installation to make sure they haven't been damaged during shipping.
3. Install the rear brick panel, by placing it against the rear of the firebox. The bottom of the brick panel rests on a small sheet metal lip, just above the air intake at the bottom rear of the Firebox. You will need to hold this panel in place while you install the right brick panel. Do not let go of the panel or it may fall forward and be damaged.
4. While holding the rear brick panel in place, slide the right along the side of the firebox toward the rear of the firebox. Each side Firebox Liner will sit upon a Firebox Liner Retainer and the top will be held between the Exhaust Baffle and the side of the firebox.

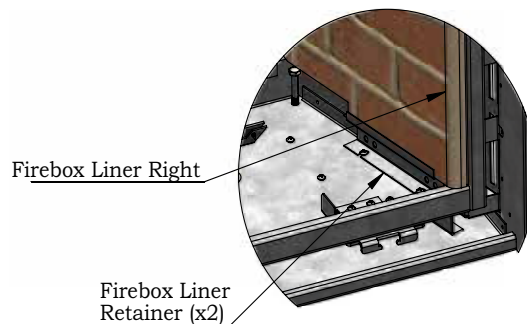

Lower Right of Firebox

6. If the brick panels are difficult to get into place the firebox liner retainer can be adjusted to accommodate the brick panel, The burner will need to be removed by removing 2 screws as shown in Diagram 4. Lift burner up and out towards you and put on a soft cloth. Loosen the 2 screws securing the Firebox liner retainers (Diagram 5) and adjust inward. Check to ensure brick panel will fit prior to tightening. Repeat for other side. Reinstall burner prior to reinstalling brick panels



Brick Panel Installation

installation

ENAMEL/STEEL PANEL INSTALLATION

IMPORTANT: THIS APPLIANCE CANNOT BE OPERATED WITHOUT PANELS INSTALLED.

Before you Start:
Black Enamel Panels
<ul style="list-style-type: none"> • Black Enamel panels must be inspected for scratches and dimples prior to installation. All claims to be recorded at this time. Claims for damage after installation will not receive consideration.
<ul style="list-style-type: none"> • Black Enamel panels will discolor a little during normal operation. This is normal and should not be considered a defect.
<p>* All hand and finger marks <i>MUST</i> be cleaned off with a soft cloth. Use an ammonia based cleaner (ie. glass cleaner) to remove any fingerprints before applying heat to the unit.</p> <p>Failure to do this will result in burn stains on panels which you will be unable to remove. Not protected by product warranty.</p>

Sheet metal components may have sharp edges. Please handle with care. The enamel panels require an insulation panel installed behind them. Failure to do so may result in an elevated operating temperature and premature failure of the appliance. The Insulation panels may contain fibre glass or ceramic elements. These may become airborne or stick to carpets and/or clothing. Handle with caution. The use of work gloves and dust masks is recommended when handling panels and insulation.

1. Remove filler sections from right and left sides of the burner and discard - see below.

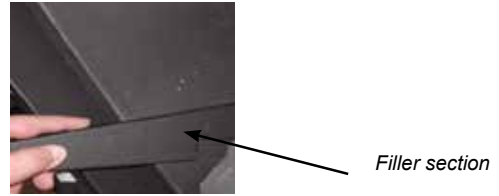

2. Place the insulation panels on the inside of their respective firebox liners. Have both the rear liner and the right liner within reach of the Firebox. The rear liner has one long edge with perpendicular lip and one long edge with a lip angled downward. The angled lip is the top of the panel. The liner sits on a sheet metal ledge at the rear of the firebox, just above the air inlet near the bottom. While holding the rear liner in place, slide the firebox liner right (and the corresponding insulation panel) into the right side of the Firebox. The side liners will sit on the firebox liner retainers and fit at the top in-between the firebox side and the exhaust baffle. The rear flange on the Firebox Liner Side, sits between the rear liner and the firebox side. When the side liner is properly installed, the front edge should sit just inside the front edge of the firebox.

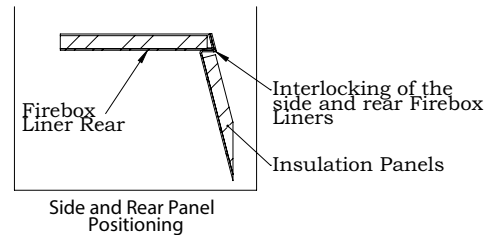
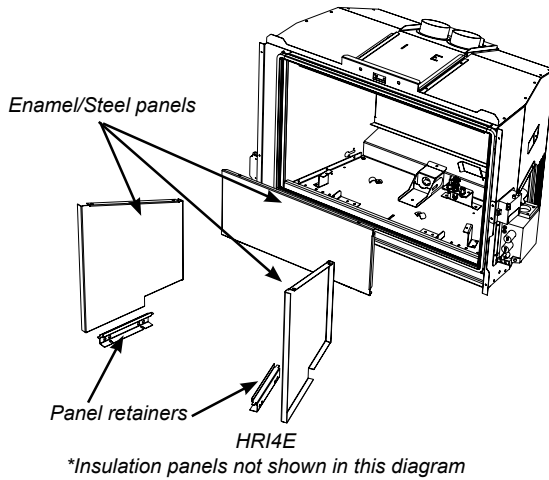

3. Install the firebox liner Left, with the corresponding Insulation Panel by sliding it into the left side of the firebox. The rear flange of the liner must fit between the firebox liner rear and the firebox. You may have to push the liner against the firebox as you push it rearward.

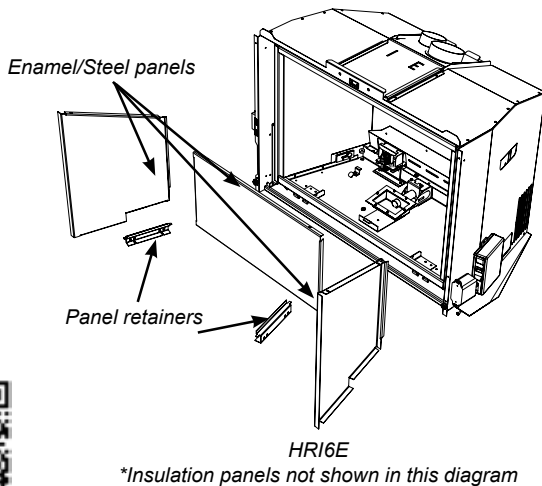

Installing Enamel/Steel Panels

GLASS DOOR REMOVAL / INSTALLATION

WARNING: Do not operate the appliance with the glass panels removed, cracked or broken. Replacement of the glass panels should be done by a licensed or qualified service person.

- 1) Insert the door tool into the lower door latch.

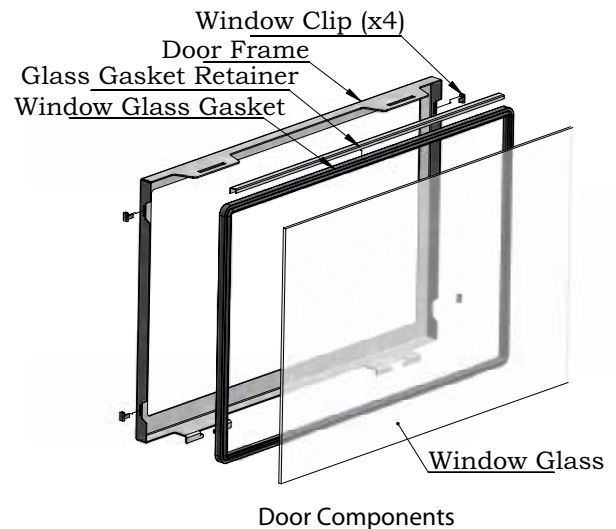
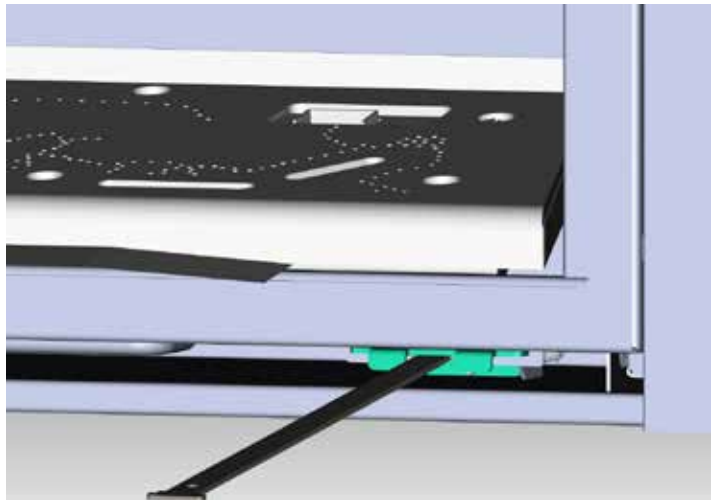
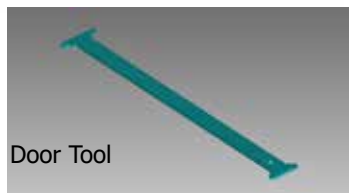
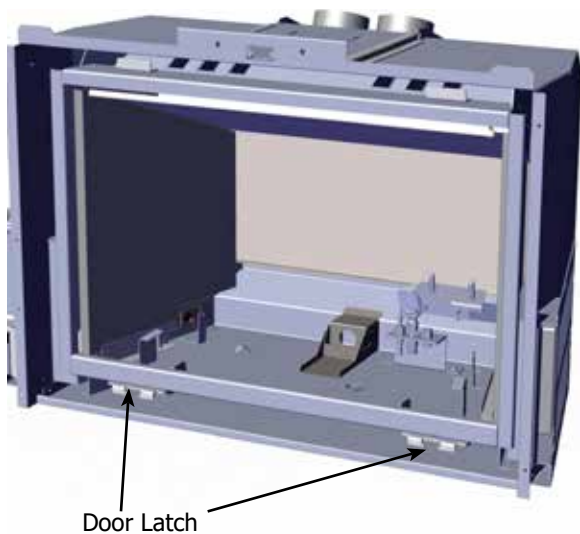

- 2) Pull forward until the lower door latch is disengaged from the door frame.
- 3) Push downward until the Lower Door Latch is below the Door Frame.
- 4) Release the lower door latch until it reaches its resting point.
- 5) Remove the door tool and repeat steps 1-5 on the other lower door latch.
- 6) Pull the bottom of the door towards you until the door is angled away from the firebox by about 30°. Lift the door up and over the upper door hooks.
- 7) To install the glass door - reverse steps.



Glass Door Cleaning & Removal

installation

VIGNETTE FACEPLATE WITH SAFETY SCREEN INSTALLATION

Black Chrome Handling Instructions

All hand and finger marks **MUST** be cleaned off with a soft cloth. Use an ammonia-based cleaner (E.g. glass cleaner) to remove any finger prints before heating the unit. Use supplied gloves when installing black chrome faceplates. **Failure to do this will result in burn stains on panels which you will be unable to remove, an issue not covered by product warranty.**

1. Pop out the tab on the right side (facing front) of the outer faceplate and place the grommet in the opening to route the power cord.
2. Install the outer faceplate and secure it with five screws for the L/HR14E and L/HRI6E, as shown below.

NOTE

- Two top corner screws can be loosely installed on the unit as the holes on the outer faceplate are keyholes.

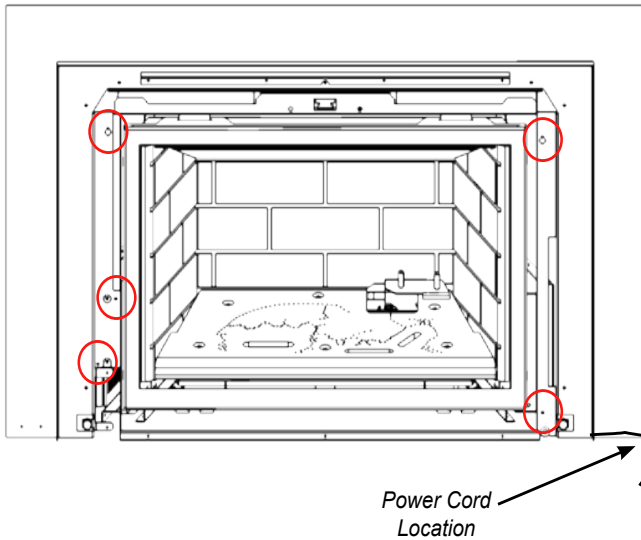

4. Install the vignette faceplate by hooking the flange over the hanger as shown below.

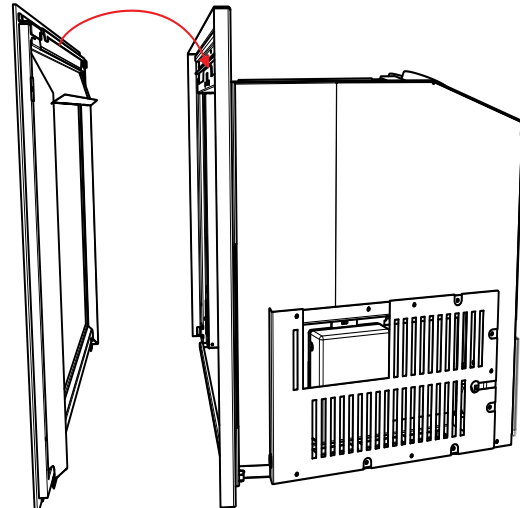

5. Ensure finger prints or smudges are removed from the faceplate before the first firing.

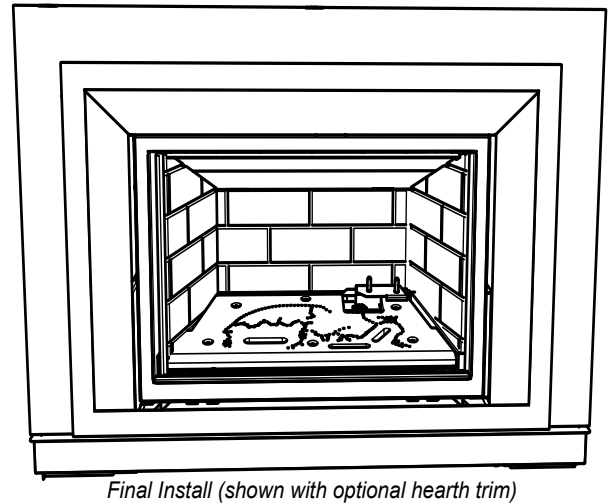

3. Route the power cord on the right side between the inner and outer profile of the faceplate. Use a grommet and wire clip to secure.

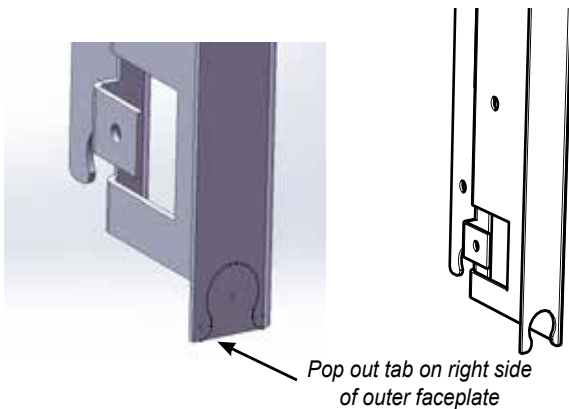

NOTE

- Pull the bottom of the vignette faceplate towards you to access the remote receiver.

INLAY INSTALLATION

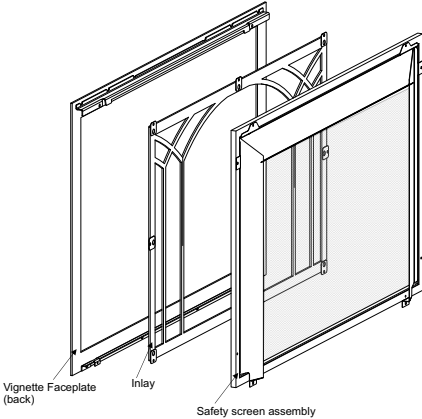
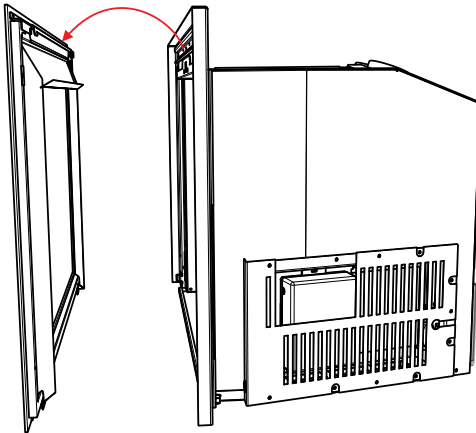

2. Remove 4 screws from the back of the Vignette faceplate in locations shown below—to remove the safety screen assembly.

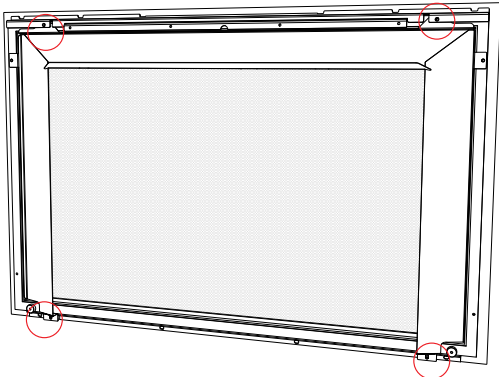

Remove 4 screws to remove safety screen assembly

4. Reinstall the Vignette faceplate with inlay onto unit—reverse Step 1.

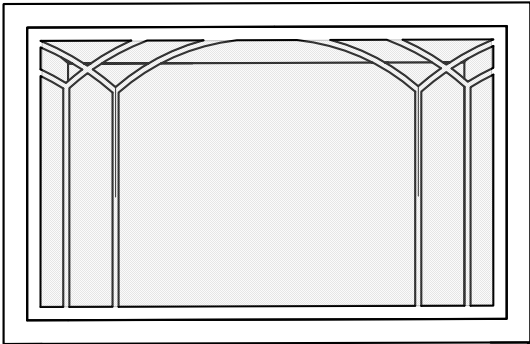

Final Install

installation

4 SIDED FACEPLATE WITH SAFETY SCREEN INSTALLATION

1. Install the outer faceplate and secure with 5 screws as shown.

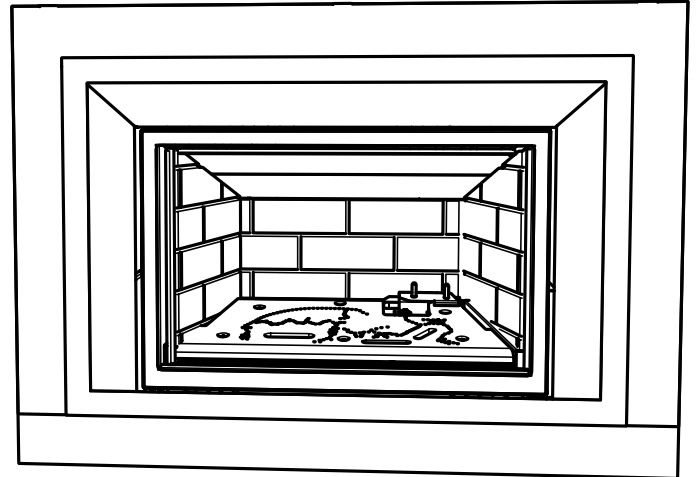
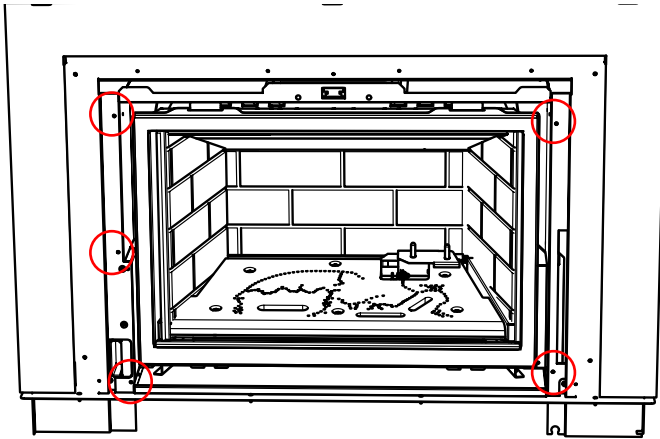

2. Install the outer faceplate by hooking the flange over the hanger as shown.

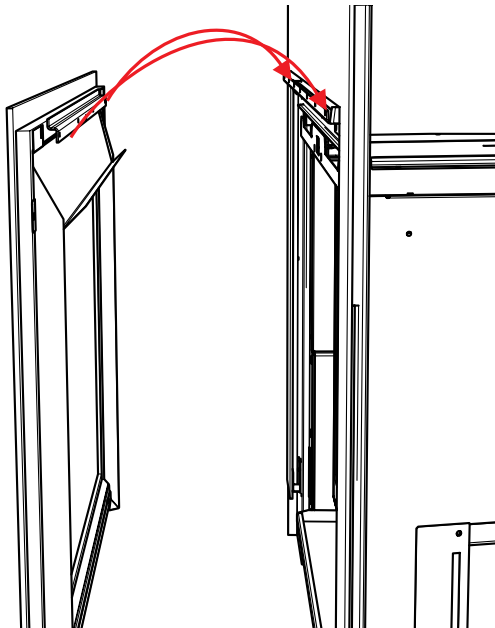

SPACER INSTALLATION

1. Remove Vignette faceplate from unit and lay on a soft surface.



2. Remove the outer faceplate by removing the 5 screws as shown.

Note: the two top and two bottom screws can be loosened - slide the outer faceplate up on out to remove.

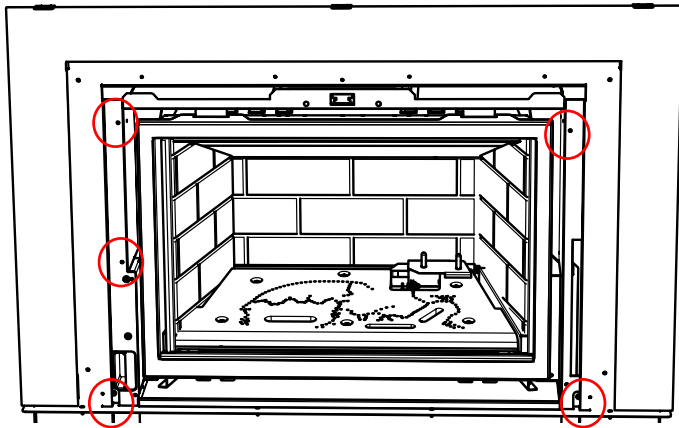

3. Separate the Outer Faceplate from the Backing Plate by removing 7 screws.

4. Place the spacer on a soft cloth on the floor. Lay the outer faceplate over the spacer and line up the 7 holes. Attach the 3 piece spacer to the back of the outer faceplate from the front with 7 screws (3 along the top and 2 on each side).

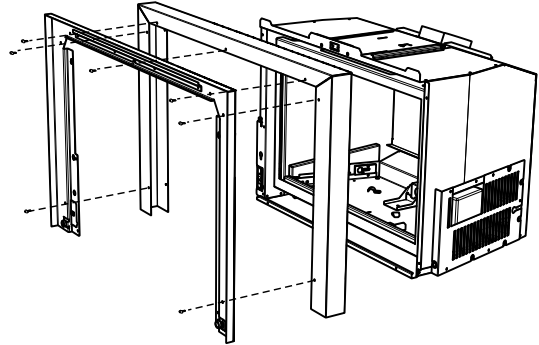

5. Reinstall the outer faceplate and spacer—reverse Step 2.

6. Reinstall the Vignette faceplate and safety screen to complete.

installation

BACKING PLATE INSTALLATION

1. Remove Vignette faceplate from unit and lay on a soft surface.



2. Remove the outer faceplate by removing the 5 screws as shown.

Note: the two top and two bottom screws can be loosened - slide the outer faceplate up on out to remove.

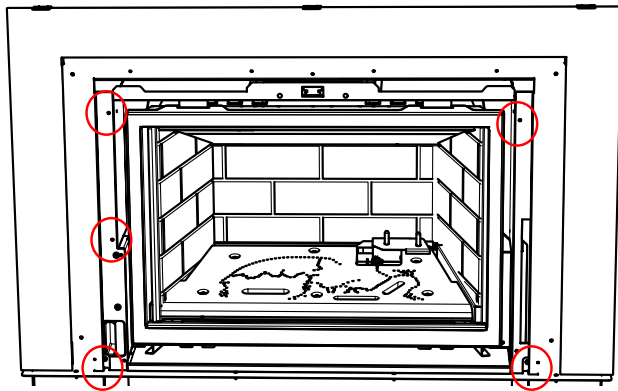

3. Attach the backing plate to the outer faceplate from the front with 7 screws (3 along the top and 2 on each side).

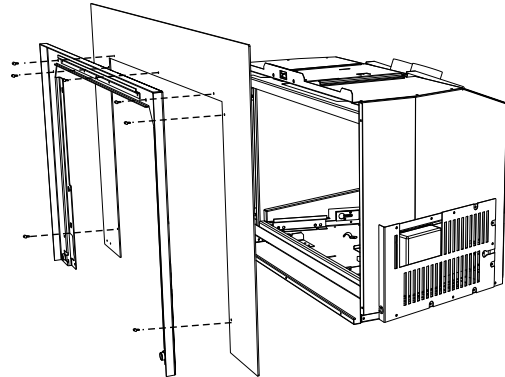

4. Reinstall the outer faceplate and backing plate—reverse Step 2.

5. Reinstall the Vignette faceplate and safety screen to complete.

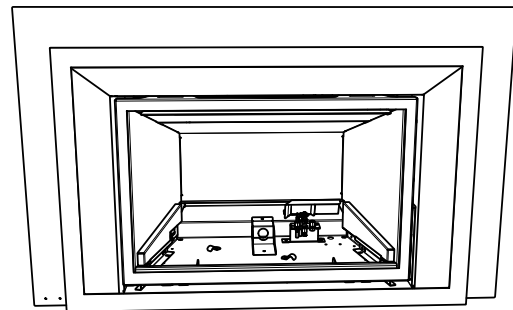

Final Install

OPTIONAL ARCHED VIGNETTE FACEPLATE INSTALLATION

- 1. Shut off unit and allow to return to room temperature
- 2. Install 4 supplied screws (loosely) onto unit in locations shown below.

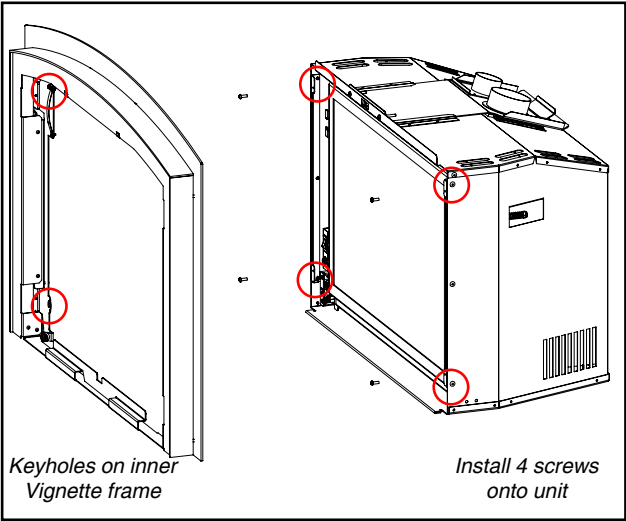

- 3. Install the inner Vignette frame by hanging the frame off the 4 screws via the keyhole openings on the frame. When in position, tighten the 4 screws.

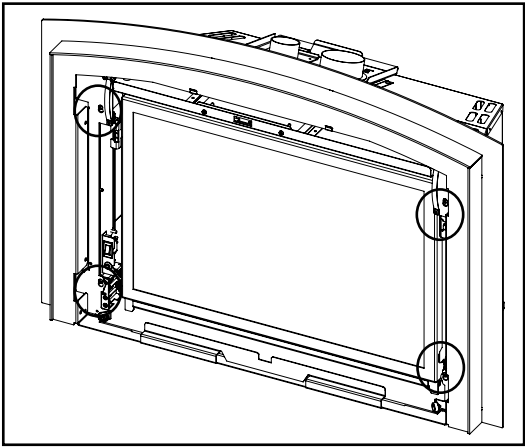

- 4. Install the safety screen into the inner Vignette frame by slightly tilting the safety screen frame and placing it up into the Vignette frame. Let the safety screen slightly drop down into position within the Vignette frame.

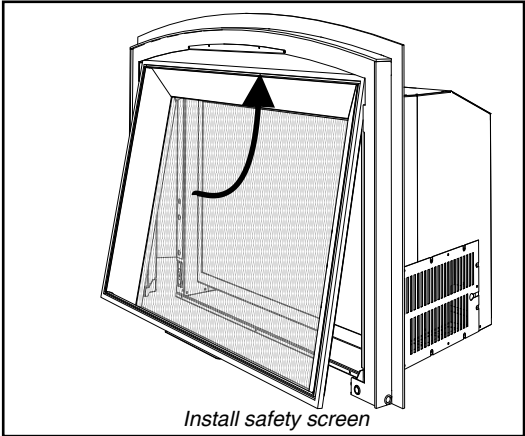

- 5. Install the outer Vignette frame onto the inner Vignette frame by hanging tabs into slots on inner Vignette frame. The bottom of the outer faceplate will be held in position by magnets.

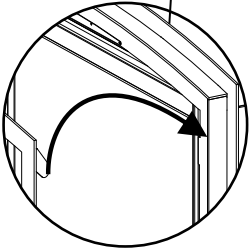
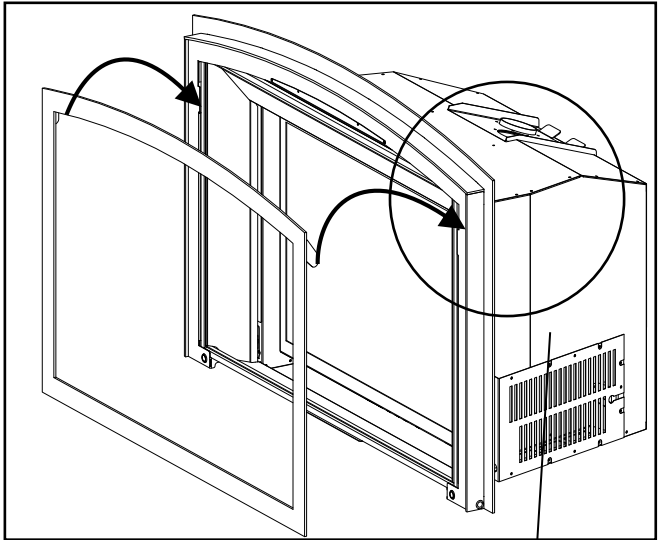

- 6. Route power cord to a near by receptacle on left hand side prior to sliding appliance into final position.

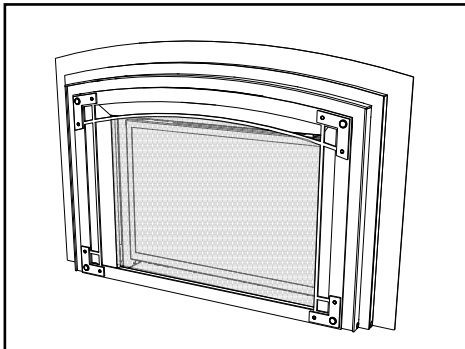
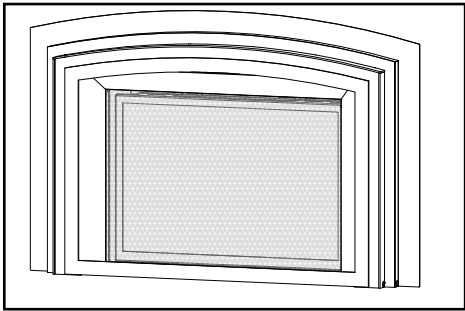

installation

OPTIONAL BACKING PLATE INSTALLATION

1. Shut off unit and allow to return to room temperature
2. Attach the backing plate with 4 screws from the back of the Vignette frame.

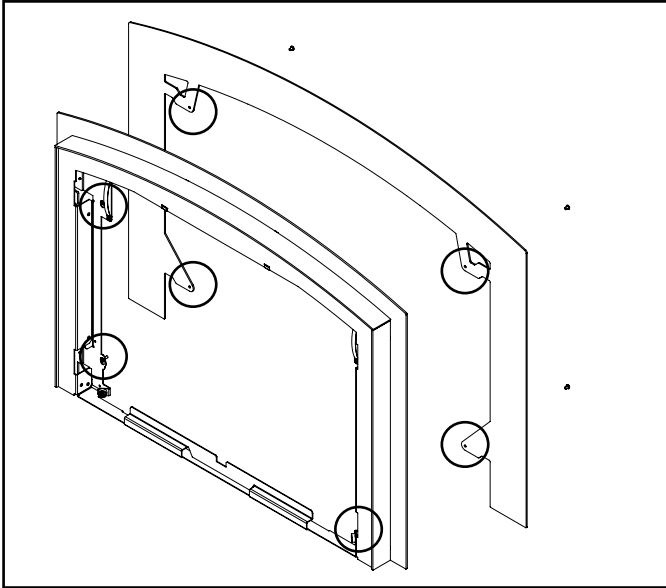

Install backing plate to inner Vignette frame with 4 screws

3. Install the backing plate + inner Vignette frame and outer Vignette frame as per Arched Vignette frame instructions.

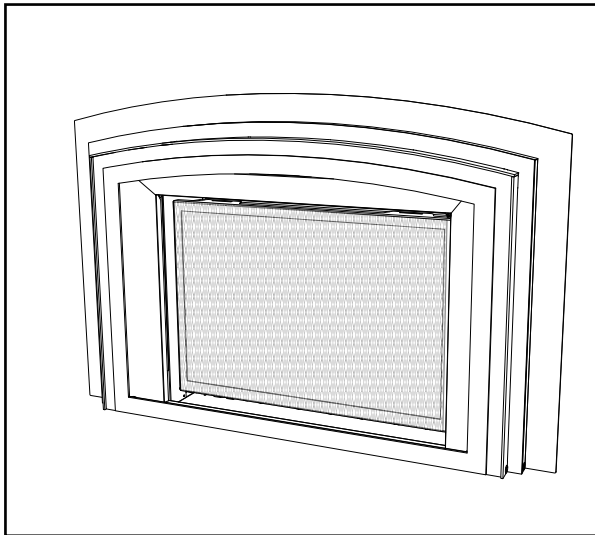

Completed Arch Vignette Faceplate with spacer and backing plate installed

OPTIONAL MANTEL DEFLECTOR INSTALLATION - VIGNETTE

NOTE: A mantel deflector may be installed to reduce the minimum mantel height. Refer to the instruction manual for minimum mantel clearances.

1. Remove Vignette faceplate from unit and lay on a soft surface.



2. Remove the outer faceplate by removing the 5 screws as shown.

Note: the two top and two bottom screws can be loosened - slide the outer faceplate up on out to remove.

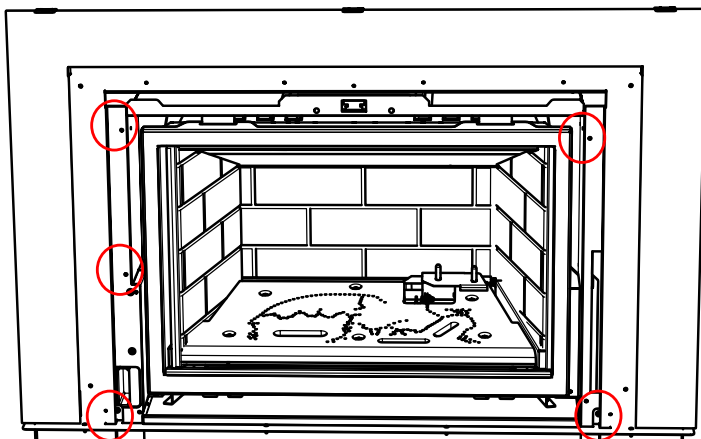

3. Separate the Outer Faceplate from the Backing Plate by removing 7 screws.

4. Install the mantel deflector in between the back of the outer faceplate and the front of the backing plate. Insert the screws from the front of the outer faceplate using 3 screws.

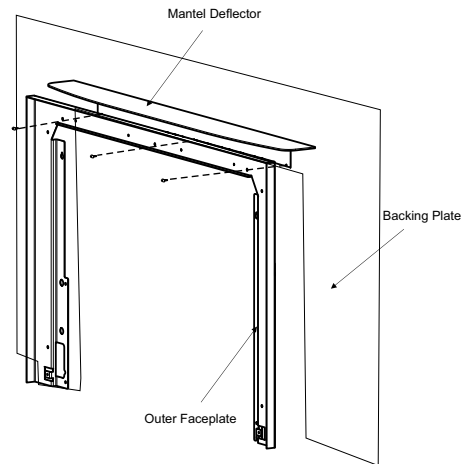

5. Reinstall the outer faceplate and spacer—reverse Step 2.

6. Reinstall the Vignette faceplate and safety screen to complete.

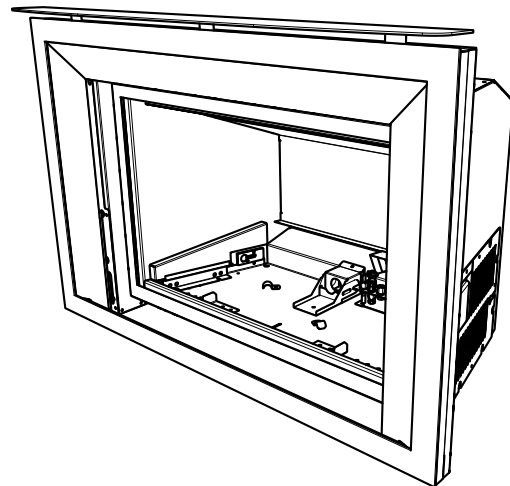

installation

OPTIONAL HEARTH TRIM INSTALLATION

Customizing the Hearth Trim:

The Hearth Trim can be adjusted to custom fit an installation by pulling apart the top piece from the bottom piece. Minimum height of the hearth trim is 2" and can be adjusted up to maximum 6".

- 1) Cut the top of the bottom piece of the hearth trim to the appropriate height using a metal cutting blade.

NOTE: The tab bends at the back of the top piece of the hearth trim should be used as the measuring point to the hearth to measure the height required.

- 2) Reattach the top piece of the hearth trim to the cut bottom piece by fitting in place.

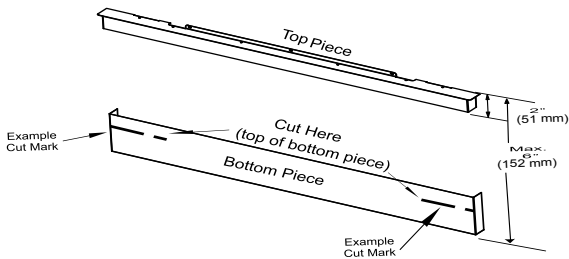

- 3) Similar to the front hearth trim, cut the top of the bottom piece of the spacer brackets to the appropriate height.

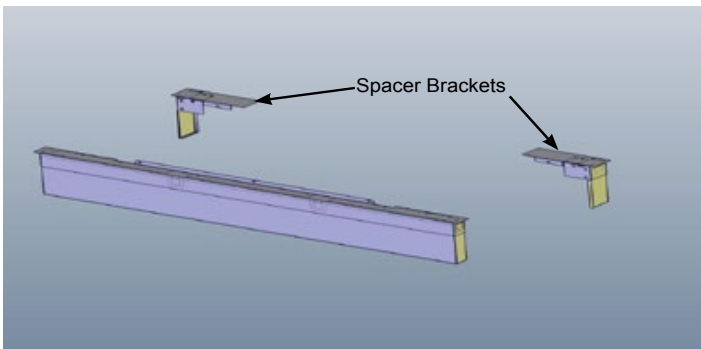

- 4) Attach the top and bottom part of the spacer brackets and then attach these spacer brackets to the assembled hearth trim with 3 screws.

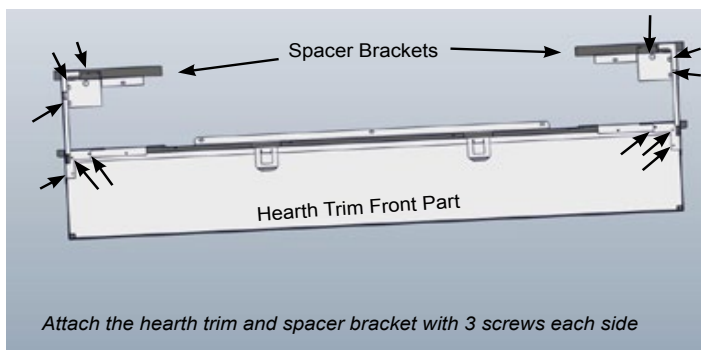

- 5) Secure the hearth trim with a clip on its side to keep it steady as shown in the diagram below.

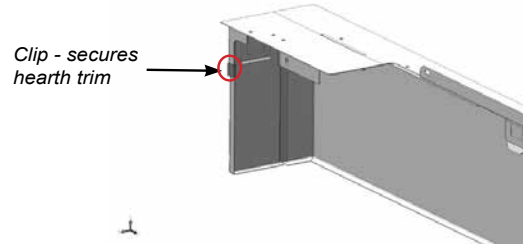

- 6) Line up the hearth trim with base of the unit and secure it with 3 screws as shown below.

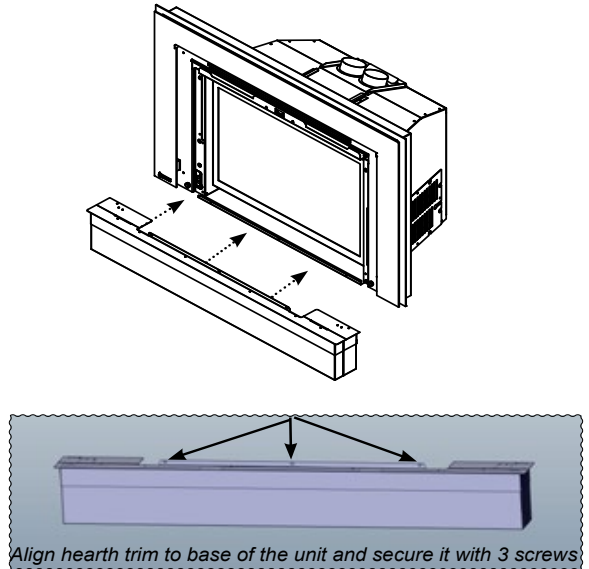

OPTIONAL HEARTH TRIM INSTALLATION - VIGNETTE FACEPLATE WITHOUT SPACER

Customizing the Hearth Trim

The Hearth Trim can be adjusted to custom fit an installation by pulling apart the top piece from the bottom piece. Minimum height of the hearth trim is 2" and can be adjusted up to maximum 6".

1. Discard the spacer brackets, as these are not required when installing the unit without spacer.
2. Cut the top of the bottom piece of the hearth trim to the appropriate height using a metal cutting blade.

NOTE: The tab bends at the back of the top piece of the hearth trim should be used as the measuring point to the hearth to measure the height required.

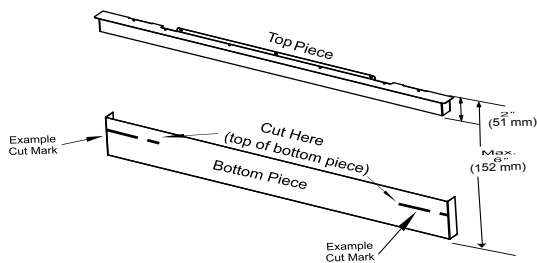

3. Reattach the top piece of the hearth trim to the cut bottom piece by fitting in place.

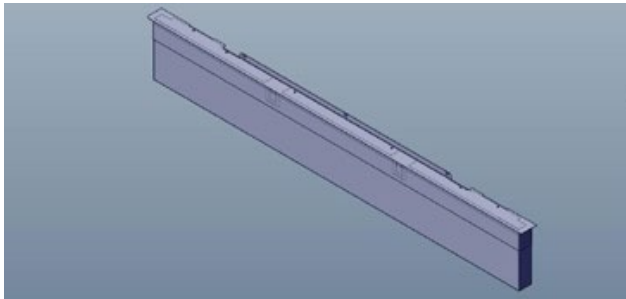

4. Line up the hearth trim with base of the unit and secure it with 3 screws as shown below.

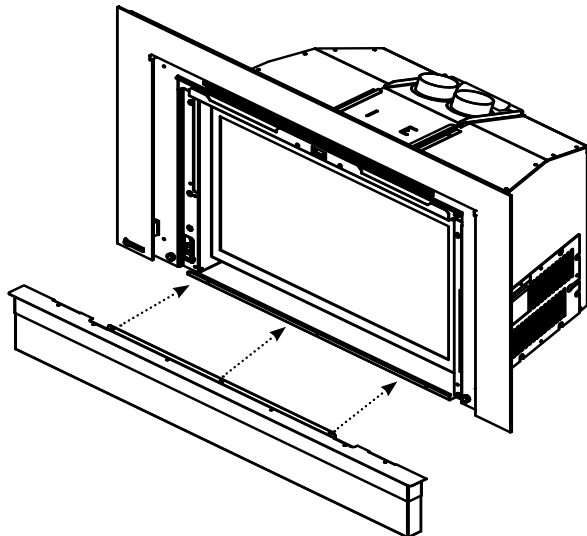

operating instructions

OPERATING INSTRUCTIONS

Before operating this appliance, proceed through the following check list.

- 1) Read and understand these Instructions before operating this appliance.
- 2) Check to see that all wiring is correct and enclosed to prevent possible shock.
- 3) Check to ensure there are no gas leaks.
- 4) Make sure the glass door is in place. Never operate the appliance with the door glass removed.
- 5) Verify that all venting and the cap is unobstructed.
- 6) Verify log /glass crystal placement. If the pilot cannot be seen when lighting the unit - the logs / crystals, or the embers have been incorrectly positioned.
- 7) The unit should never be turned off and on again without a minimum of a 60 second wait.
- 8) When lighting the appliance, the inside of the glass may fog up. This will burn off after a few minutes of operation.

DO NOT BURN THE APPLIANCE WITH THE GLASS DOOR REMOVED.

ON DEMAND PILOT LIGHT

Important:

This appliance has a timer built into the pilot light. The timer starts when the main burner has been shut-off via the remote control, thermostat, or ON/OFF switch. Once the burner is shut off, the timer is set for 7 days. If there is no call for heat within a 7 day period -- the pilot is designed to extinguish.

See instructions in this manual for lighting pilot.

FIRST FIRE

The first fire in your stove is part of the paint curing process. To ensure that the paint is properly cured, it is recommended that you burn your fireplace for at least four (4) hours the first time you use it with the fan on. When first operated, the unit will release an odour caused by the curing of the paint, the burning off of any oils remaining from manufacturing. Smoke detectors in the house may go off at this time. Open a few windows to ventilate the room for a couple of hours.

The glass panel may require cleaning after the unit has cooled down.

DO NOT ATTEMPT TO CLEAN THE GLASS WHILE IT IS HOT.

Note: When the glass is cold and the appliance is lit, it may cause condensation and fog the glass. This condensation is normal and will disappear in a few minutes as the glass heats up.

DO NOT BURN THE APPLIANCE WITHOUT THE GLASS FRONT IN PLACE.

During the first few fires, a white film may develop on the glass front as part of the curing process. The glass should be cleaned or the film will bake on and become very difficult to remove. Use a non-abrasive cleaner and NEVER clean the glass while it is hot.

AUTOMATIC CONVECTION FAN OPERATION

The fan operates automatically. The fan will turn on as the stove comes up to operating temperature. After the unit has been turned off and the unit cooled to below a useful heat output range the fan will shut off automatically.

NORMAL OPERATING SOUNDS OF GAS APPLIANCES

It is possible that you will hear some sounds from your gas appliance. This is perfectly normal due to the fact that there are various gauges and types of steel used within your appliance. Listed below are some examples. All are **normal operating sounds** and should not be considered as defects in your appliance.

Blower:

Regency gas appliances use high tech blowers to push heated air farther into the room. It is not unusual for the fan to make a "whirring" sound when ON. This sound will increase or decrease in volume depending on the speed setting of your fan speed control.

Burner Tray:

The burner tray is positioned directly under the burner tube(s) and logs and is made of a different gauge material from the rest of the firebox and body. Therefore, the varying thicknesses of steel will expand and contract at slightly different rates which can cause "ticking" and "cracking" sounds. You should also be aware that as there are temperature changes within the unit these sounds will likely re-occur. Again, this is normal for steel fireboxes.

Blower Thermodisc:

When this thermally activated switch turns ON it will create a small "clicking" sound. This is the switch contacts closing and is normal.

Pilot Flame:

While the pilot flame is on it can make a very slight "whisper" sound.

Gas Control Valve:

As the gas control valve turns ON and OFF, a dull clicking sound may be audible, this is normal operation of a gas regulator or valve.

Unit Body/Firebox:

Different types and thicknesses of steel will expand and contract at different rates resulting in some "cracking" and "ticking" sounds will be heard throughout the cycling process.

COPY OF LIGHTING INSTRUCTION PLATE

FOR YOUR SAFETY READ BEFORE LIGHTING
POUR VOTRE SÉCURITÉ – À LIRE AVANT LA MISE EN MARCHÉ

WARNING: If you do not follow these instructions exactly, a fire or explosion may result causing property damage, personal injury or loss of life. Improper installation, adjustment, alteration, service or maintenance can cause injury or property damage. Refer to the owner's information manual provided with this appliance. For assistance or additional information consult a qualified installer, service agency or gas supplier.

AVERTISSEMENT: Quiconque ne respecte pas scrupuleusement les instructions de la présente notice risque de déclencher un incendie ou une explosion pouvant entraîner des dégâts matériels ou des blessures pouvant être mortelles. Tout défaut d'installation, de réglage, de modification, de service ou d'entretien peut entraîner des blessures ou des dommages matériels. Reportez-vous au manuel d'utilisation fourni avec cet équipement. Pour obtenir de l'aide ou des informations complémentaires, consulter un installateur ou un service d'entretien qualifié, ou le fournisseur de gaz.

A) This appliance is equipped with an ignition device which automatically lights the pilot.
Do not try to light the pilot by hand.

B) **BEFORE OPERATING** smell all around the appliance area for gas. Be sure to smell next to the floor because some gas is heavier than air and will settle on the floor.

WHAT TO DO IF YOU SMELL GAS

- Do not try to light any appliance.
- Do not touch any electric switch, do not use any phone in your building.
- Leave the building immediately.
- Immediately call your gas supplier from a neighbours phone. Follow the gas supplier's instructions.
- If you cannot reach your gas supplier, call the fire department.

C) Do not use this appliance if any part has been under water. Immediately call a qualified service technician to inspect the appliance and to replace any part of the control system and any gas control which has been underwater.

A) Cet appareil est muni d'un dispositif d'allumage qui allume automatiquement la veilleuse.
Ne tentez pas d'allumer la veilleuse manuellement.

B) **AVANT LA MISE EN MARCHÉ**, reniflez tout autour de l'appareil pour détecter une odeur de gaz. Reniflez au niveau du plancher, car certains gaz sont plus lourds que l'air et peuvent s'accumuler au niveau du sol.

QUE FAIRE SI VOUS SENTEZ UNE ODEUR DE GAZ :

- Ne tentez pas d'allumer l'appareil
- Ne touchez à aucun interrupteur; n'utilisez pas le téléphone se trouvant dans le bâtiment.
- Quittez immédiatement le bâtiment.
- Appelez immédiatement votre fournisseur de gaz depuis un téléphone extérieur. Suivez les instructions du fournisseur.
- Si vous ne pouvez pas rejoindre le fournisseur, appelez le service incendie.

C) N'utilisez pas cet appareil s'il a été plongé dans l'eau, même partiellement. Faites inspecter l'appareil par un technicien qualifié et remplacez tout élément du système de contrôle ou de commande qui a été plongé dans l'eau.

CAUTION: Hot while in operation. Do not touch. Severe burns may result. Due to high surface temperatures keep children, clothing and furniture, gasoline and other liquids having flammable vapors away. Keep burner and control compartment clean. See installation and operating instructions accompanying appliance.

ATTENTION : Surfaces chaudes lorsque l'appareil est en marche. Ne pas toucher. Risque de brûlures graves. En raison des températures élevées, les enfants, les vêtements et le mobilier, le carburant et tout autre liquide aux vapeurs inflammables doivent être tenus éloignés de l'appareil. Nettoyer régulièrement le brûleur et le compartiment des commandes. Voir les consignes d'installation et d'utilisation fournies avec l'appareil.

OPERATING INSTRUCTIONS / CONSIGNES DE FONCTIONNEMENT

1) **STOP!** Read the safety information above on this label.

2) Ensure the Main switch is in the ON position and/or the wall mounted battery holder (if equipped) is in the <REMOTE> position.

3) Press and release the ON/OFF button on the remote handheld transmitter. An audible beep should be heard from the receiver. If not using the remote, the unit can also be turned on by sliding the battery holder switch to the <ON> position (if equipped).

4) After approximately 4 seconds the spark ignition system will spark for 60 seconds to light the main burner.

5) The unit will turn on.

Note: The first attempt to ignition will last approximately 60 seconds. If there is no flame ignition (rectification) the board will stop sparking for approximately 35 seconds. After this wait time, the board will start a second try for ignition by sparking for approximately 60 seconds. If there is still no positive ignition after the second attempt the board will go into lock out. The system will need to be reset as follows (after going into lock out mode):

- a) Wait 5 minutes - turn the system off by pressing the ON/OFF button on the remote.
- b) After approximately 2 seconds press the ON/OFF button again.
- c) Unit will repeat step 2.

6) If the appliance will not operate, follow the instructions, "To Turn Off Gas to Appliance" and call your service technician or gas supplier. This appliance is equipped with an on-demand pilot that shuts off after seven days.

1) **STOP!** Lisez les instructions de sécurité sur la portion supérieure de cette étiquette.

2) S'assurer que le commutateur principal est en position ON et/ou que le bloc-piles mural (le cas échéant) est en position <REMOTE>.

3) Appuyer sur la touche ON/OFF de la télécommande puis relâcher. Un bip sonore retentira depuis le récepteur. Si vous n'utilisez pas la télécommande, l'appareil peut également être allumé en faisant glisser le commutateur du bloc-piles sur la position <ON> (le cas échéant).

4) Après environ 4 secondes, le système d'allumage produira une étincelle pendant 60 secondes pour allumer le brûleur principal.

5) L'appareil s'allumera.

Remarque : Au premier allumage, le système tente d'allumer les flammes pendant 60 secondes. Si l'essai est infructueux, le système fera une pause de 35 secondes. C'est ce qu'on appelle l'étape de rectification. Ce délai écoulé, le système tente à nouveau d'allumer les flammes en produisant des étincelles pendant 60 secondes. Si les flammes ne s'allument toujours pas, le système se met en mode verrouillage.

Il faut alors le réinitialiser en suivant les étapes ci-dessous (pour le déverrouiller) :

- a) Attendre 5 minutes et éteindre l'appareil en appuyant sur la touche ON/OFF de la télécommande.
- b) Attendre 2 secondes et appuyer encore une fois sur la touche ON/OFF.
- c) L'appareil répètera l'étape 2.

6) Si l'appareil ne fonctionne pas, suivez les instructions "Pour couper le gaz au niveau de l'appareil" et appelez un technicien qualifié ou votre fournisseur de gaz.

Cet appareil est équipé d'une veilleuse sur demande qui s'éteint après sept jours.

TO TURN OFF GAS TO APPLIANCE / POUR COUPER LE GAZ AU NIVEAU DE L'APPAREIL

1) Press the ON/OFF button on the remote or slide the wall mount switch to the "OFF" position.

2) If service is to be performed—you must disconnect power and shut off gas to the unit.

1) Appuyer sur la touche ON/OFF de la télécommande ou faites glisser l'interrupteur mural sur la position "OFF".

2) Lors de l'entretien de l'appareil, vous devez débrancher l'alimentation électrique et couper le gaz alimentant l'appareil.

DO NOT REMOVE THIS INSTRUCTION PLATE

NE PAS ENLEVER CETTE ÉTIQUETTE D'INSTRUCTIONS

919-649b

maintenance

MAINTENANCE INSTRUCTIONS

- 1) Always turn the gas valve to off before cleaning. For relighting, refer to lighting instructions. Keep the burner and control compartment clean by brushing and vacuuming at least once a year. When cleaning the logs, use a clean soft paint brush as the logs are fragile and easily damaged.
- 2) Clean (never when unit is hot) appliance, door and louvers with a damp cloth. Never use an abrasive cleaner. The gold louvers (and optional gold door) may be scratched if abrasives are used to clean them.
The heater is finished in a heat resistant paint and should only be refinished with heat resistant paint (not with wall paint). Regency uses StoveBrite Paint - Metallic Black #6309.
- 3) Make a periodic check of burner for proper position and condition. Visually check the flame of the burner periodically, making sure the flames are steady; not lifting or floating. If there is a problem, call a qualified service person.
- 4) The appliance and venting system must be inspected before use, and at least annually, by a qualified field service person, to ensure that the flow of combustion and ventilation air is not obstructed.
During the annual service call, the burners should be removed from the burner tray and cleaned. Replace the embers but do not block the pilot.
- 5) Keep the area near the appliance clear and free from combustible materials, gasoline and other flammable vapours and liquids
- 6) Each time the appliance is lit, it may cause condensation and fog the glass. This condensation and fog is normal and will disappear in a few minutes as the glass heats up.
Never operate the appliance without the glass properly secured in place or with the door open.
- 7) Do not use this appliance if any part has been under water. Immediately call a qualified service technician to inspect the appliance and to replace any part of the control system and any gas control which has been under water.
- 8) Periodically check the pilot flames. Correct flame pattern has two strong blue flames: 1 flowing around the flame sensor, and 1 flowing across the burner (it does not have to be touching the burner).

WARNING: CHILDREN AND ADULTS SHOULD BE ALERTED TO THE HAZARDS OF HIGH SURFACE TEMPERATURE AND SHOULD STAY AWAY TO AVOID BURNS OR CLOTHING IGNITION. YOUNG CHILDREN SHOULD BE CAREFULLY SUPERVISED WHEN THEY ARE IN THE SAME ROOM AS THE APPLIANCE.

CAUTION: ANY SAFETY SCREEN OR GUARD REMOVED FOR SERVICING AN APPLIANCE MUST BE REPLACED PRIOR TO OPERATING THE APPLIANCE.

CLOTHING OR OTHER FLAMMABLE MATERIAL SHOULD NOT BE PLACED ON OR NEAR THE APPLIANCE.

DOOR GLASS

Your Regency insert is supplied with high temperature, Neoceram ceramic glass that will withstand the highest heat that your unit will produce. If your glass requires cleaning, we recommend using an approved glass cleaner available at all authorized dealers. Do not use abrasive materials. Do not clean the glass when hot.

In the event that you break your glass by impact, purchase your replacement from an authorized Regency dealer only, and follow our step-by-step instructions for replacement.

Warning: Do not operate appliance with glass panels removed, cracked or broken. Replacement of the glass should be done by a licensed or qualified service person.

CAUTION & WARNINGS:

- * Do not clean when the glass is hot.
- * The use of substitute glass will void all product warranties.
- * Care must be taken to avoid breakage of the glass.
- * Do not strike or abuse the glass.
- * Do not operate this fireplace without the glass front or with a cracked or broken glass front.
- * Wear gloves when removing damaged or broken glass.
- * Replacement of the glass panel(s) should be done by a licensed or qualified service person.

GLASS REPLACEMENT

In the event that you break your glass by impact, purchase your replacement from an authorized Regency® dealer only. Replacement Neoceram glass (#940-371/P) is shipped with a gasket.



Glass Door Cleaning & Removal

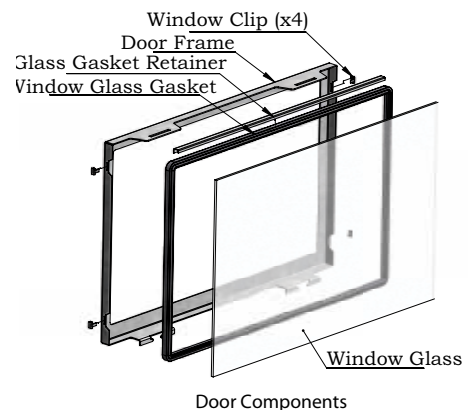

PILOT ADJUSTMENT

Periodically check the pilot flames. Correct flame pattern has two strong blue flames: 1 flowing around the flame sensor and 1 flowing across the burner (it does not have to be touching the burner).

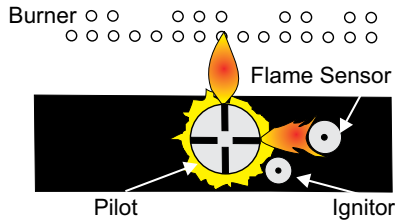

Note: If you have an incorrect flame pattern, contact your Regency® dealer for further instructions.

Incorrect flame pattern will have small, probably yellow flames, not coming into proper contact with the rear burner or flame sensor.

GENERAL VENT MAINTENANCE

Conduct an inspection of the venting system semi-annually. Recommended areas to inspect as follows:

- 1) Check the Venting System for corrosion in areas that are exposed to the elements. These will appear as rust spots or streaks, and in extreme cases, holes. These components should be replaced immediately.
- 2) Remove the Termination Cap, and shine a flashlight down the Vent. Remove any bird nests, or other foreign material.
- 3) Check for evidences of excessive condensation, such as water droplets forming in the inner liner, and subsequently dripping out the joints, Continuous condensation can cause corrosion of caps, pipe, and fittings. It may be caused by having excessive lateral runs, too many elbows, and exterior portions of the system being exposed to cold weather.
- 4) Inspect joints, to verify that no pipe sections or fittings have been disturbed, and consequently loosened. Also check mechanical supports such as Wall Straps, or plumbers' tape for rigidity.

LOG REPLACEMENT

The unit should never be used with broken logs. Turn off the gas valve and allow the unit to cool before opening door to carefully remove the logs. The pilot light generates enough heat to burn someone. If for any reason a log should need replacement, you must use the proper replacement log. The position of these logs must be as shown in the diagram under Log Installation.

NOTE: Improper positioning of logs may create carbon build-up and will alter the unit's performance which is not covered under warranty.

GLASS GASKET

If the glass gasket requires replacement use glass gasket (Part # 846-683).

maintenance

GLASS CRYSTAL BURNER REMOVAL / INSTALLATION - HRI4E

Disconnect unit from gas supply and allow unit to cool before removing burner.

GLASS BURNER REMOVAL

- 1) If already installed, remove glass crystals and ceramic spa stones.
- 2) Remove filler sections from right and left sides of burner. Discard filler section if enamel panels are to be installed - see below.



Filler section

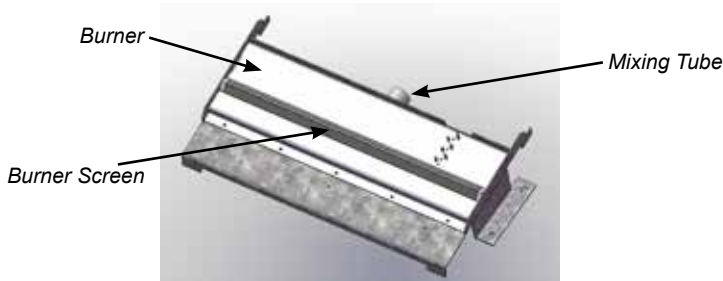

- 3) Remove the 2 screws as shown. Lift the burner with both hands.

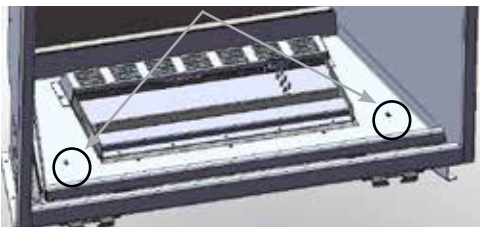

- 4) Pull gently upwards and outwards to the front of the firebox.
- 5) Continue onto burner installation.

GLASS BURNER INSTALL

- 1) Lift the burner assembly with both hands. Point the mixing tube towards the rear of the firebox. Lean the rear of the burner assembly downward. Partially lift the burner assembly so that the mixing tube will then slide into the air shutter.
- 2) Lower the front edge of the burner assembly so that the burner front mounting tab rests on the burner mounting bracket left and right, near the front of the firebox. These tabs will not line up unless the mixing tube is inside the air shutter at the rear of the firebox.

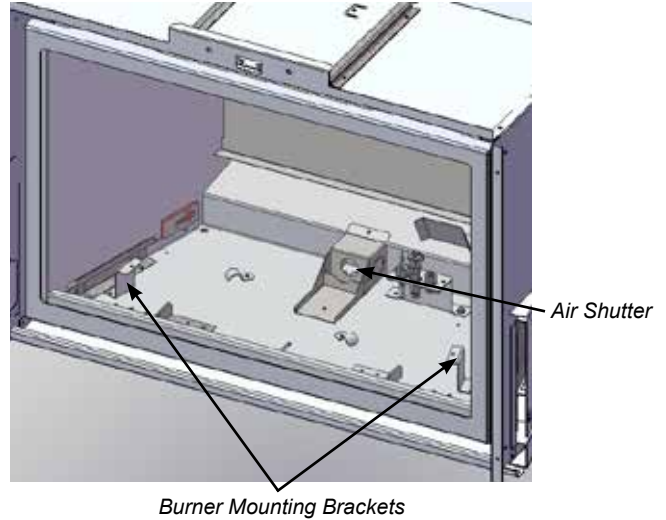

Care must be taken when installing the burner into the firebox. Do not damage, knock or scrap the pilot assembly. The flame sensor and ignition lead are fragile and can be damaged easily.

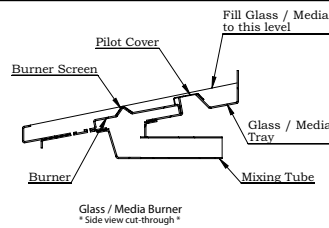

- 3) Place the Burner Cover Screen over the Burner Ports. Place the Pilot Cover over the rear gap between the Burner and the Media Tray. This will sit around the Pilot Provision.
- 4) Distribute the glass crystals throughout the Media Tray. The media should be level with the side of the Media Tray.

**** Do not install glass or other media over or in front of the Pilot Provision as shown.**

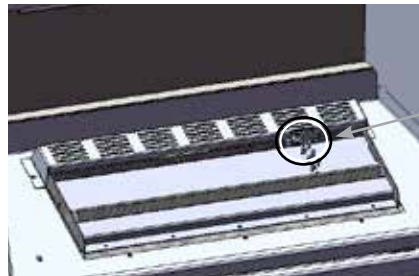

Important: Do not install glass or other media in this area, as this will block the path of the pilot to the burner.

LRI4E CERAMIC BURNER REMOVAL / INSTALLATION

REMOVAL

- 1) Remove left/right filler sections - see below.
Discard fillers only if inner panels are being installed.



Left /right filler sections.

- 2) Remove burner by removing left and right screws off the burner bracket.



- 3) Lift the Burner slightly while pulling forward to clear the mixing tube.



- 4) To install - reverse Steps 3-2, see Step 1 for correct installation tips.

INSTALLATION

Care must be taken when installing the burner into the firebox. Do not damage, knock or scrape the pilot assembly. The flame sensor and ignition lead are fragile and can be damaged easily.

*Satin black paint is included if touch ups are required.

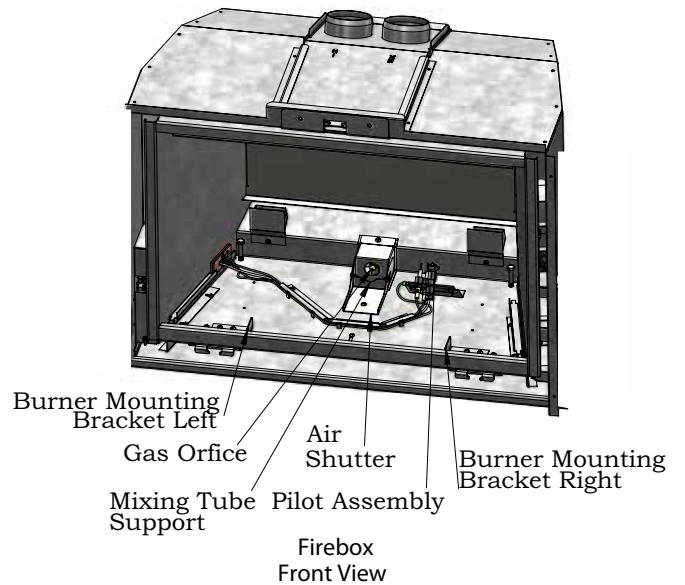

Important Note:

A correctly installed burner - the burner is back far enough, lower the front edge so that the front flange of the burner (underneath) sits down into the grooves in the burner mounting brackets Left and Right. There will be a small gap between the Ceramic Burner and the firebox Bottom Flange. The Burner should be situated about 1/4" (6mm) inside the front edge of the firebox.



maintenance

FAN MAINTENANCE - WITH GTMF REMOTE CONTROL

Note: To access the side and rear access panels both the gas and venting will need to be disconnected (see vent/flue installation in this manual) for proper removal along with the faceplate. There is no access to the blower from the front of this appliance. The appliance will need to be slid out and turned around to gain access to the screws securing the fan in place.

- Before you begin:**
- **Shut off the gas supply to the unit.**
 - **Disconnect all electrical supply to the unit.**
 - **Always let the appliance cool to room temperature before servicing.**

1. Remove 7 screws and loosen 4 screws along the bottom to remove fan access panel - see Diagram 1a
Remove 4 screws to remove side access panel - see Diagram 1b

○ = Remove
□ = Loosen

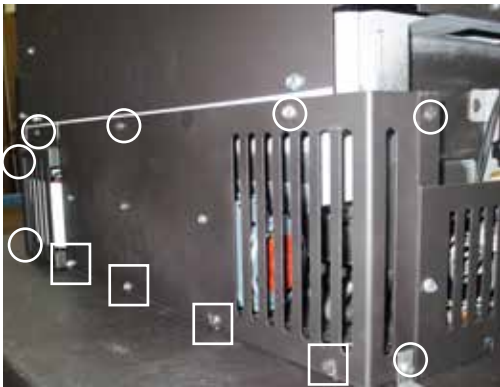

Diagram 1a

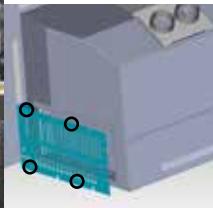

Diagram 1b

2. Disconnect the fan wire harness through the rear panel. Disconnect 2 x 1/4" spade connectors to the fan terminals. Disconnect the ground wire by removing screw.

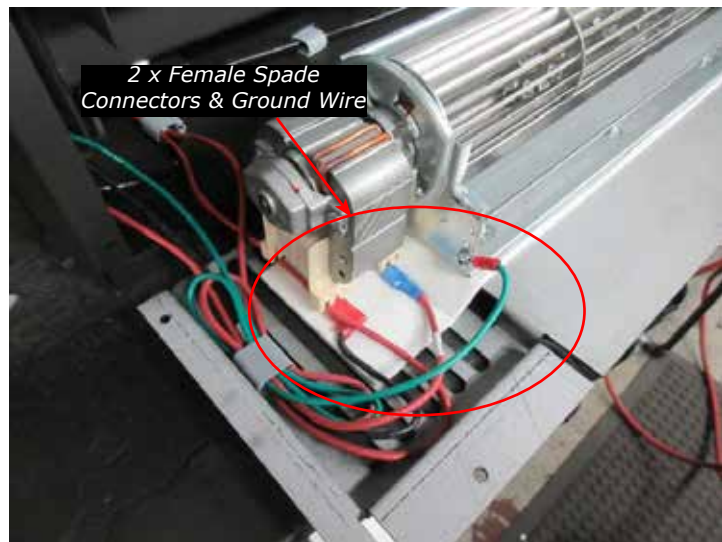

Diagram 2

3. Remove fan and fan access panel from unit.



Diagram 3

4. Remove fan from back access panel by removing 3 screws from the outside of fan access panel.

5. To install - reverse steps.

WARNING
Electrical Grounding Instructions
This appliance is equipped with a three-prong (grounding) plug for your protection against shock hazard and should be plugged directly into a properly grounded three-prong receptacle. Do not cut or remove the grounding prong from this plug.

Location of fan thermidisc if ever requiring replacement. The thermidisc will slide out if pulling back towards you and is also located on the back of the appliance. Disconnect 2 x 1/4" spade connectors to replace. Note: Removing the fan assembly will expose the thermidisc.

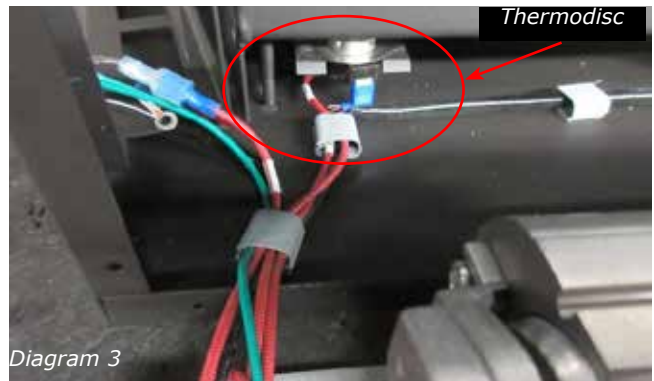

Diagram 3

Fan control module is located on the right hand side of appliance if facing it from the front. Shown with metal cover removed. The fan control will be held in with 2 screws. The FCM COM wire would need to be disconnected also if the fan control module needs to be replaced.

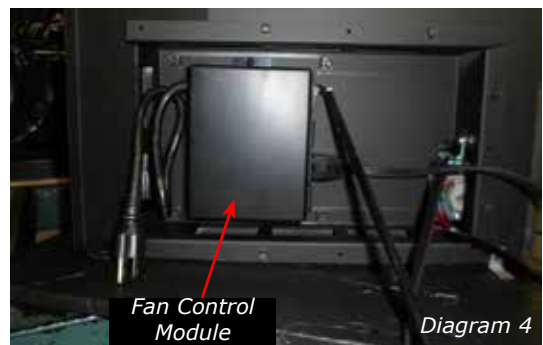

Diagram 4

VALVE REPLACEMENT

Before you begin:

* **Shut off the gas supply to the unit.
Disconnect all electrical supply to the unit.**

Always let the appliance cool to room temperature before servicing.

Remove unit flue collars.

- 1) Remove the Left Control Panel Cover.
- 2) Disconnect 3 wires (EV1, EV2 and ground) leading to the valve as shown below.

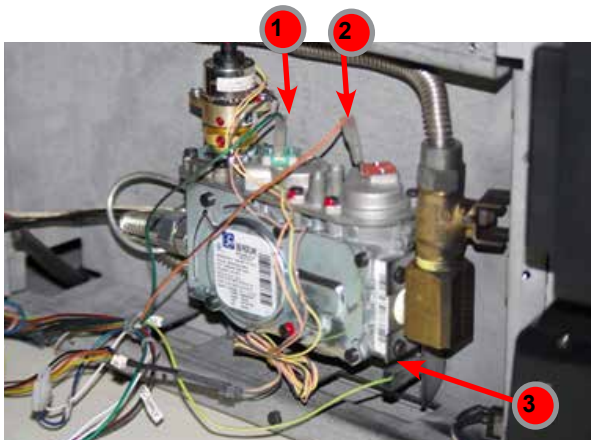

- 3) Disconnect the Pressure Regulator cable.

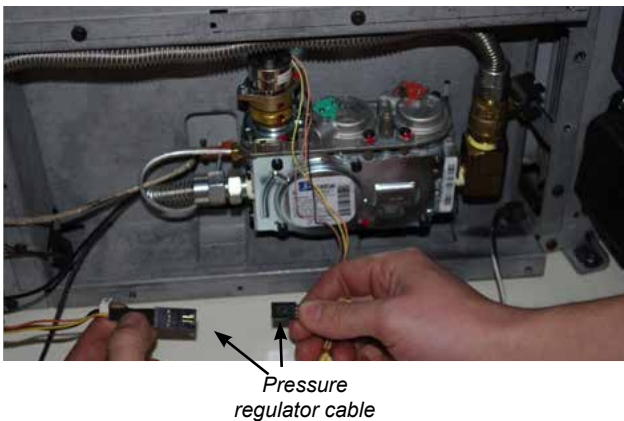

- 4) Disconnect the Gas Orifice supply line from the outlet of the Gas Valve.



- 5) Disconnect the Pilot Supply Line from the Gas Valve



- 6) Disconnect the Gas Supply Line from the On/Off Safety Shut off Valve.



- 7) Remove both Screws that secure the Gas Valve Mounting brackets, both sides.



maintenance

8) Remove the Gas Valve by lifting upwards and outwards.



9) Secure the Valve Assembly by the 90 Elbow Fitting in a sturdy table vice. Using a crescent wrench, loosen the valve from the Elbow fitting.

****** Do not place the valve in the vice by any other method than what is shown. Holding the Valve in the vice will damage the Gas Valve and may cause malfunction. ******



10) Remove the 2 screws that hold the Right Side Valve Mounting Bracket onto the Valve.



11) There is a provision in the Valve body casting that is designed to be used as a gripping point for assembly with other components. This is the portion of the valve that can be placed in a machine vice.



12) Place the Gas Valve into the machine vice using the provision as described above. Do not over tighten the vice. Remove the Flare Fitting from the gas outlet side of the valve.



13) Remove the 2 screws that secure the left side valve mounting bracket from the gas valve.



14) Replace the gas valve with the new unit and re-assemble by reversing disassembly steps 2-13.

15) Reconnect the gas and electrical supply to the unit. Once the unit has been re-fired, use a soapy water mixture to check all fittings and gas supply lines for gas leaks.

GAS MAINTENANCE - RECOMMENDED ANNUAL ROUTINE

In order for your Regency appliance to continue to provide comfort to your home periodic maintenance must be performed to ensure it is operating at peak efficiency. The items in the list should be checked by a licensed gas service technician during the annual service check. Your unit may require more frequent maintenance checks if you notice any changes in how it operates. Operational changes to look for can include, but are not limited to, extended start up time, increased fan noise, residue/carbon build up, white build up on the glass/firebox, increased operating noise etc. Should any of these or other conditions arise, discontinue use and schedule a service check with your local licensed gas technician. The list below shows items your licensed service technician will need to check and service at least annually.

Clean

- Glass
- Interior bricks / panels
- Burner ports & burner air shutter
- Fan blades
- Log set
- Pilot orifices
- Pilot hood (change as needed)
- Flame sensor (electronic ignition models)
- Flame electrode
- Burner orifice
- Thermocouple (millivolt models)
- Thermopile (millivolt models)

Inspect

- Pilot assembly
- Burner
- Pressure relief gaskets/doors
- Flue connector gasket if present
- Door seal
- Firebox
- Venting
- Batteries (remote handheld, remote receiver, DC sparker, change as needed)
- Burner media (change as needed)
- Air shutter setting
- Wiring

Check

- Voltage on thermocouple/thermopile (millivolt models)
- Ohms reading on flame sense (electronic ignition models)
- Inlet/outlet fuel pressures as per rating plate
- Voltage/ohms readings on gas valve
- Ohms reading to on/off switch circuit (Millivolt models)

Gas Leak Tests

- Check main gas line connection to valve
- Check shut off valve connections
- Check connection at gas valve outlet
- Check connection at main burner orifice
- Check pilot fuel line at valve and at pilot assembly

parts list

MAIN ASSEMBLY

	Part #	Description		Part #	Description
1	399-121	Door Frame	*	904-943	Orifice mount
2	846-683	2 1/2" Wide Glass Gasket Tadpole Tape (11') (936-159)		396-032	Air Shutter
2a	396-112	Window Gasket Retainer		396-033	Burner Mounting Bracket
3	940-371/P	Glass / includes gasket		396-116	Orifice Mounting Gasket
*	396-045	Burner Mounting Bracket Right	*	396-513	Bottom Door Latch Assy
*	396-111	Burner End Right	*	904-946	NG orifice #37
6	399-117	Control Cover		904-947	LP orifice #53
7	911-139	Pilot Assembly NG SIT	*	396-125	Pilot Shield
	911-281	Pilot Assembly LP SIT	*	396-046	Burner Mounting Bracket - L
	910-100	Pilot Orifice - NG	*	396-113	Pilot Line Cover
	910-037	Pilot Orifice - LP	*	904-691	Glass Clip Retainer (ea)
*	396-111	Burner End Right	*	911-013	Proflame Wire Harness w/ IPI/IPI Switch
9	396-010	Exhaust Baffle	*	911-080	Wire harness w/40" extension
*	396-101	Light Cover	*	399-977	LP Conversion Kit
12	396-042F	Slide Tool	*	399-930	Ceramic Log Kit (6 pc) (LRI4E)
*	416-535	Flue Connector Plate Assy	*	399-530	Ceramic Burner (LRI4E)
15	911-228/P	Receiver	*	396-901	Brick Panels - Brown (LRI4E)
16	911-265	Proflame DFC board	*	396-902	Brick Panels - Red (LRI4E)
17	399-125	Control Cover (L)	*	396-903	Brick Panels - Black (LRI4E)
*	904-165	Connector 3/8"MPT - 3/8"Flare	*	396-908	Enamel Panels
19	911-030	Fan Control Module	*	398-525/P	Glass Burner Assembly (HRI4E)
20	911-084	Valve NG 885	*	Various	Glass Crystals (HRI4E)
	911-085	Valve LP 885	*	396-094	Glass Tray (HRI4E)
	399-574/P	Valve Assembly NG	*	398-013	Stainless Steel Pilot Cover (HRI4E)
	399-576/P	Valve Assembly LP	*	399-100	Mesh Screen (HRI4E)
*	911-111	Flame Sensor	*	904-790	Magnets (ea)
*	911-110	Flame Electrode		919-380	Manual
*	911-039	Pilot Hood	*	911-071/P	Fan Motor Only
*	910-591	Pilot tube w/nuts	*	911-149	Fan Thermodisc
21	399-523	Flush Front Flue Adaptor Plate	*	911-030	Fan Control Module
22	396-018	Flue Adaptor Gasket	*	911-175/P	Remote Control (Hand held) GTMF - Black
*	904-944	90° elbow 3/8"MPT-3/8"Flare	*	910-592	Remote Control (Hand held) GTMF - Silver
*	911-338/P	SIT Proflame receiver	*	904-943	Gas supply line (outlet to burner orifice)
*	911-074	Pilot Assy Ground Wire	*	911-093	10 ft. extension cord
*	396-043	Firebox Liner Retainers	*	911-137	Pilot Hood Holding Clip
*	396-114	Burner End - L	*	396-086	Heat Exchange Return
			*	298-930/P	Driftwood Log Set Complete HRI4E NG Only
			*		Part Not Shown

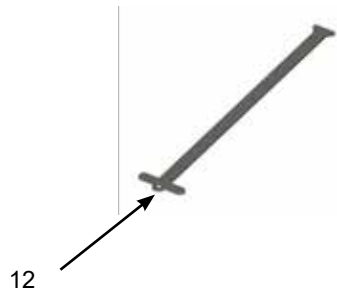
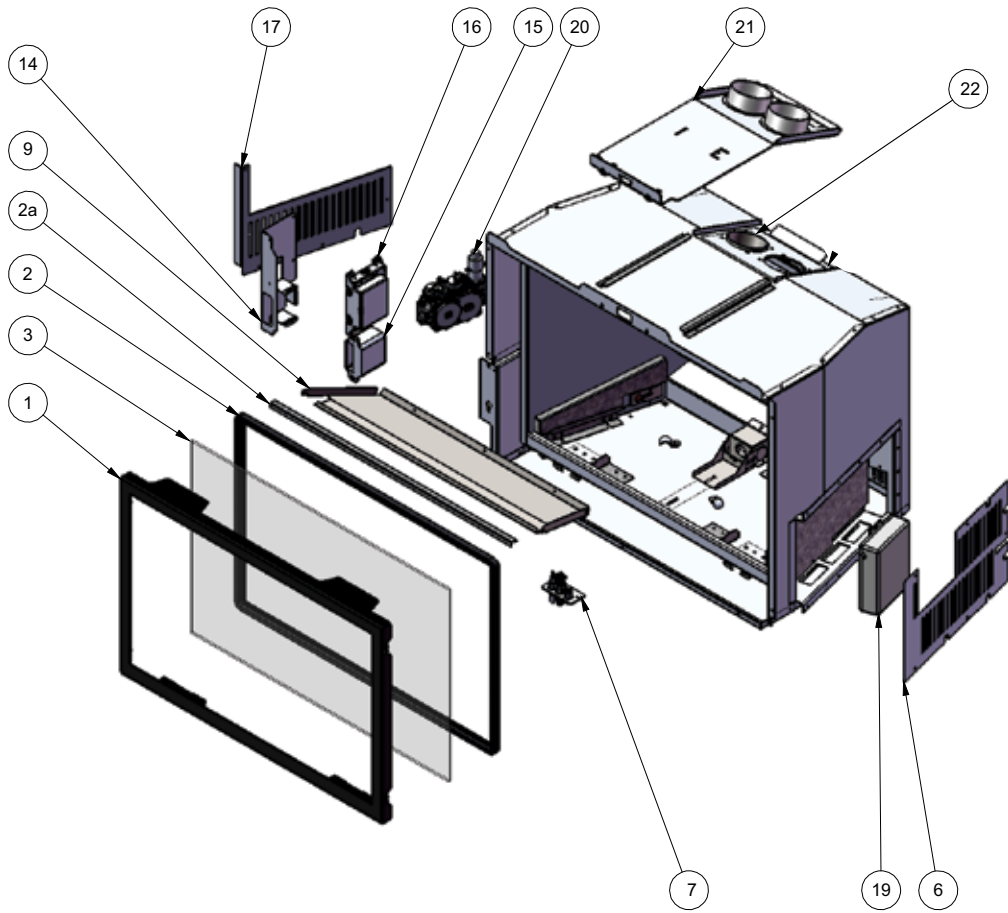

parts list

VIGNETTE FACEPLATE

	Part #	Description
1	399-825	Backing Plate Vignette Small
1	399-826	Backing Plate Vignette Medium
1	399-827	Backing Plate Vignette Oversize
2	399-818	Spacer - Black
3	399-853	Faceplate Vignette - Metallic Black (2 pieces)
	399-854	Faceplate Vignette - Platinum (2 pieces)
	399-852	Faceplate Vignette - Black Chrome (2 pieces)
	399-851	Faceplate Vignette -Tuscan Sunset (2 pieces)
	399-855	Faceplate Vignette - Tudor Metallic Black

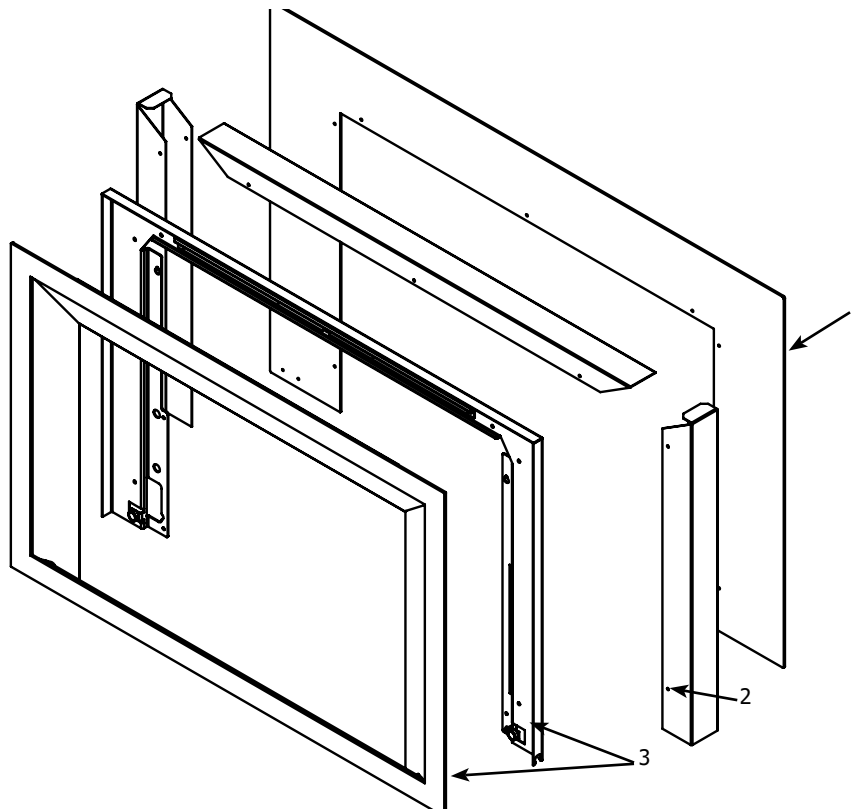

Part #	Description (Parts Not Shown)
399-811	Vignette Door Inlay Tuscan Sunset
399-812	Vignette Door Inlay Black Chrome
399-813	Vignette Door Inlay Metallic Black
399-814	Vignette Craftsman Inlay Tuscan Sunset
399-815	Vignette Craftsman Inlay Black Chrome
399-816	Vignette Craftsman Inlay Metallic Black
399-819	Hearth Trim Adjustable
399-820	Mantel Deflector

Part #	Description (Parts Not Shown)
399-828	Backing Plate 4-Sided Vignette
399-831	Backing Plate Custom 3-Sided Vignette
399-832	Backing Plate Custom 4-Sided Vignette

ARCHED VIGNETTE FACEPLATE

Part #	Description	Part #	Description
1	Front Plate Arched Vignette	15	399-843 Arched Vignette Assembly
2	399-164 Mounting Bracket (left)	16	904-791 Cup Magnet 1/2" x 5/8" OD (Each)
3	399-165 Mounting Bracket (right)	17	904-790 Magnet Round 1/2" x 1/8" (Each)
4	Midplate	18	948-020 Clip Spring (Each)
5	Edge Frame - No Knockout		
6	Edge Frame w/o Knockout (right)		
7	Top Edge Trim		
9	Top Scratch Guard		
10	399-847 Backing Plate		
12	399-845 Decorative Arched Front Assembly		
13	Screen and Panels Assembly		
14	399-840 Spacer Assembly		

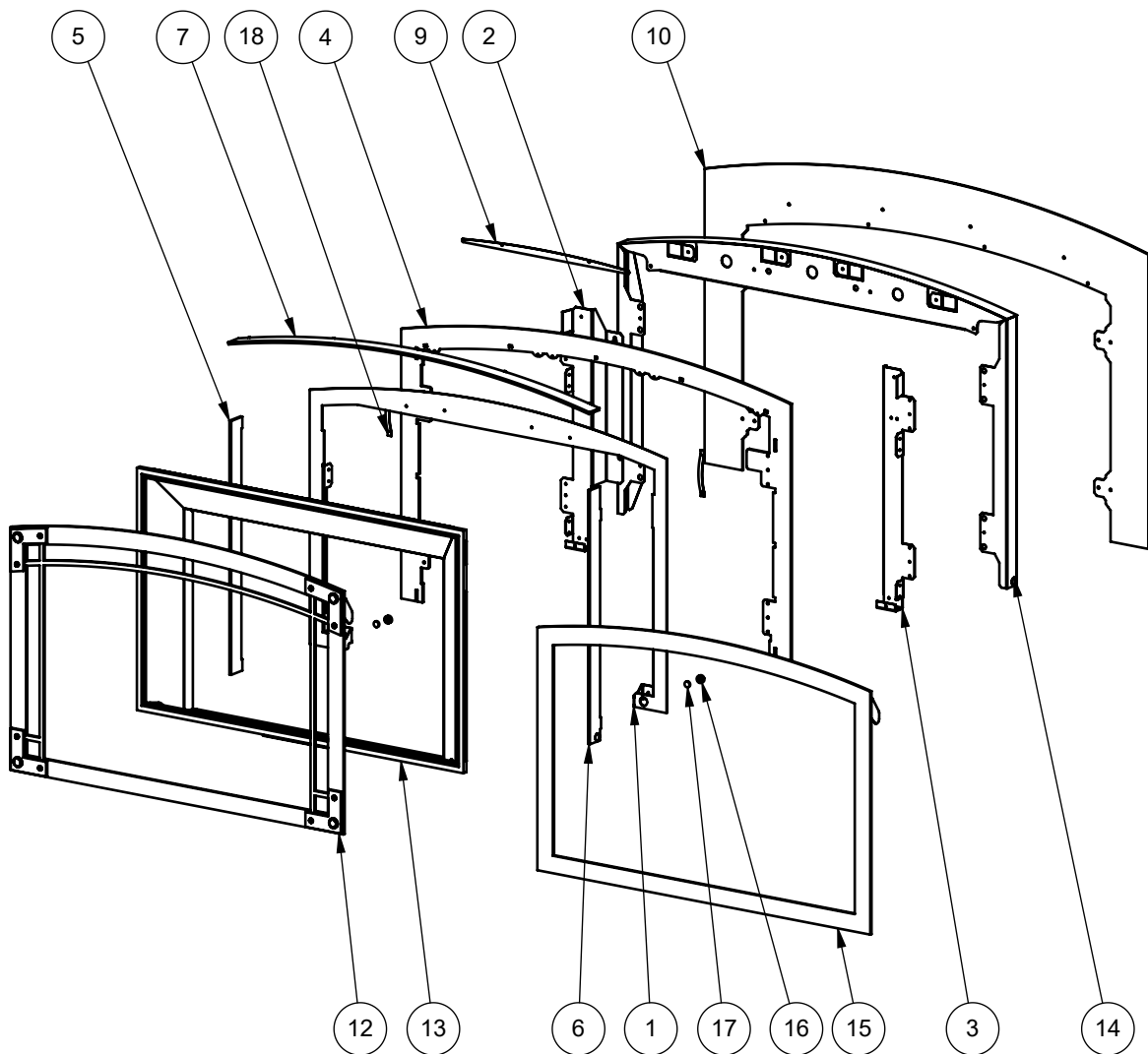

warranty

Indoor Gas Product Warranty

Limited Lifetime Warranty

FPI Fireplace Products International Ltd. (for Canadian customers) and Fireplace Products US, Inc. (for US customers) (collectively referred to herein as “FPI”) extends this Limited Lifetime Warranty to the original purchaser of this Appliance provided the product remains in the original place of installation. The items covered by this Limited Lifetime Warranty and the period of such coverage are set forth in the table below.

An Appliance in this policy is defined as an Indoor Gas Fireplace, Indoor Gas Insert, Indoor Gas Freestanding Stove.

This Appliance has only been certified and listed for use indoors.

This Limited Lifetime Warranty starts on the day the Appliance was purchased.

The Limited Lifetime Warranty is not transferable, amendable or negotiable under any circumstances.

Indoor Gas Products Warranty Coverage Parts and Labor	Limited Lifetime	5 years	2 years	1 year	Subsidized Labor Coverage* (Years)
Firebox and Heat Exchanger	✓				3
Steel Burner Tube	✓				3
Glass Thermal breakage only	✓				3
All painted Surrounds/Inlays Finishes		✓			3
Brick Panels/Log sets/Ceramic Burners		✓			3
All Castings		✓			3
Valve assembly and all gas control components (Pilot assembly, flame sensors, Spark Electrode, Pilot Tubing, Orifices, Thermocouple, Thermopile)			✓		2
All Other Electrical components (Ignition Control Boards, Wiring, Switches, Blowers, Blower Control Module, Battery Pack, Remote Control Systems)			✓		2
Enamel Panels			✓		1
Venting/Venting Components			✓		1
All Stainless steel surrounds All black chrome Brushed nickel/Antique copper Faceplates/surrounds All Inner/Outer Black Glass panels				✓	1
All Firebox Media (Crystals, Fire beads, Volcanic, Ceramic, Spa Stones, River Pebbles)				✓	1
All hardware				✓	1
WIFI Dongle				✓	1
Mesh/Glass Safety Barriers				✓	1
Accent Light Bulbs				✓	1
Glass (Crazing)				✓	1

Note: Warranty coverage noted above may not be applicable as components/options vary based on appliance purchased.

Conditions:

Warranty protects against defect in manufacture or FPI factory-assembled components only, unless herein specified otherwise.

***This warranty does not cover dealer travel costs, mileage, fuel, tolls for diagnostic or service work. All labor rates paid to authorized dealers are subsidized, pre-determined rates. Dealers may charge you for travel and additional time beyond their subsidy.**

Any part(s) found to be defective during the warranty period as outlined above will be repaired or replaced at FPI's option through an accredited distributor, dealer or pre-approved and assigned agent; provided that the defective part is returned to the distributor, dealer or agent for inspection if requested by FPI. Alternatively, FPI may, at its discretion, fully discharge all of its obligations under warranty by refunding the verified purchase price of the product to the original purchaser. The purchase price must be confirmed by the original Bill of Sale. **The authorized selling dealer, or an alternative authorized FPI dealer if pre-approved by FPI, is responsible for all in-field diagnosis and service work related to all warranty claims. FPI is not responsible for results or costs of workmanship of unauthorized FPI dealers or agents in the negligence of their service work.**

At all times, FPI reserves the right to inspect reported in the field/on location complaints of products claimed to be defective before processing or authorizing any claim. Failure to allow this upon request will void the warranty.

All warranty claims must be submitted by the dealer servicing the claim, including a copy of the Bill of Sale (proof of purchase by you). All claims must be complete and provide full details as requested by FPI to receive consideration for evaluation. **Incomplete claims may be rejected.**

Replacement Appliances to the original purchaser are limited to one per warranty term. Appliances must be installed according to all manufacturers' instructions as per the manual. All Local and National required codes must be met.

The installer is responsible for ensuring the Appliance is operating as designed at the time of installation.

The original purchaser is responsible for the annual maintenance of the Appliance, as outlined in the owner's manual. As outlined below, the warranty may be voided due to problems caused by a lack of maintenance.

Purchased parts: Repair/replacement parts purchased by the consumer from FPI after the original coverage has expired on the Appliance will carry a **90-day** warranty from the purchase date, valid with a receipt only. Any item shown to be defective will be repaired or replaced at our discretion. No labor coverage is included with these parts.

Special Finishes - One year on brushed nickel, black chrome and antique copper faceplates/surrounds. You can expect some changes in color as the product "ages" with constant heating and cooling. FPI warrants the product for any manufacturing defects on the original product. However, the manufacturer's warranty does not cover changing colors and marks, i.e. fingerprints, etc. applied after the purchase of the product. Damage from the use of abrasive cleaners is not covered by warranty.

If freight damage has been found either externally or internally, the dealer must be informed within 3 days. All claims as a result of damage must be submitted by the dealer servicing the claim, including a copy of the Bill of Sale (proof of purchase). All claims must be complete and provide full details as requested by FPI to receive consideration for evaluation. **Incomplete claims may be rejected.**

As this is a Limited Lifetime Warranty, if the Appliance needs to be replaced, the Appliance that was purchased at the time of sale might not be replaced with exactly the same model Appliance. In that case, FPI will replace your Appliance with one that is similar at the time of replacement under the terms of this Limited Lifetime Warranty, but **ONLY** in the event that an item covered by the Limited Lifetime Warranty is found to be defective. Please refer to the table on first page of this warranty for items covered by the Limited Lifetime Warranty. Product changes might be the result of the original Appliance being discontinued, changes in regulatory requirements, product advancements, etc., which are beyond the control of FPI. **This Limited Lifetime Warranty does not cover any installation costs, or costs associated with changes of required clearances for the replacement Appliance, hearth pads, mantles, facing and/or facing materials such as framing, completed walls made of drywall, wood, non-combustible board, tile, brick, stone, marble etc., venting/chimney systems, or components of the chimney system.**

If a suitable replacement is not available, FPI will refund **50%** of the purchase price of the Appliance and any applicable FPI accessories (faceplates, brick panels, media, etc.) purchased at the time of sale. **In no event will FPI refund any portion of the purchase price of, or reimburse costs associated with, any other items, including without limitation, installation of a new Appliance, changes of required clearances for a new Appliance, hearth pads, mantles, facing and/or facing materials such as framing, completed walls made of drywall, wood, non-combustible board, tile, brick, stone, marble etc., venting/chimney systems, or components of the chimney system. A copy of the receipt or bill of sale will be necessary to validate the purchase price.**

warranty

Exclusions:

This Limited Lifetime Warranty does not extend to paint, rust or corrosion of any kind due to a lack of maintenance or improper venting, combustion air provision, corrosive chemicals (i.e. chlorine, salt, air, etc.), door or glass gasketing, batteries, color fading, carbon/sooting of the log sets due to use and does not cover lava rock, platinum/glowing embers, vermiculite.

Malfunction, damage or performance-based issues as a result of environmental conditions, location, chemical damages, downdrafts, installation error, an installation by an unqualified installer, incorrect chimney components (including but not limited to cap size or type), operator error, abuse, misuse, use of improper fuels, lack of regular maintenance and upkeep, acts of God, weather-related problems from hurricanes, tornados, earthquakes, floods, lightning strikes/bolts or acts of terrorism or war, which result in a malfunction of the Appliance are not covered under the terms of this Limited Lifetime Warranty.

FPI has no obligation to enhance or modify any Appliance once manufactured (i.e. as products evolve, field modifications or upgrades will not be performed on existing Appliances).

Any Appliance showing signs of neglect or misuse will not be covered under the terms of this warranty policy and may void this warranty, including Appliances with rusted or corroded fireboxes that have not been reported as rusted or corroded within **three (3)** months of installation/purchase.

Appliances which show evidence of being operated while damaged, or with problems known to the purchaser and causing further damages will void this warranty.

Appliances where the serial no. has been altered, deleted, removed or made illegible will void this warranty.

Minor movement, expansion and contraction of the steel is normal and is not covered under the terms of this warranty.

Freight damages for products or parts are not covered under the terms of the warranty.

Products made or provided by other manufacturers and used in conjunction with the FPI Appliance without prior authorization from FPI may void this warranty.

Limitations of Liability:

The original purchaser's exclusive remedy under this warranty, and FPI's sole obligation under this Limited Lifetime Warranty, express or implied, in contract or in tort, shall be limited to replacement, repair, or refund, as outlined above. IN NO EVENT WILL FPI BE LIABLE UNDER THIS WARRANTY FOR ANY INCIDENTAL OR CONSEQUENTIAL COMMERCIAL DAMAGES OR DAMAGES TO PROPERTY. TO THE EXTENT PERMITTED BY APPLICABLE LAW, FPI MAKES NO EXPRESS WARRANTIES OTHER THAN THE WARRANTY SPECIFIED HEREIN. THE DURATION OF ANY IMPLIED WARRANTY IS LIMITED TO DURATION OF THE EXPRESSED WARRANTY SPECIFIED ABOVE. IF IMPLIED WARRANTIES CANNOT BE DISCLAIMED, THEN SUCH WARRANTIES ARE LIMITED IN DURATION TO THE DURATION OF THIS WARRANTY.

Some US states do not allow limitations on how long an implied warranty lasts, or allow exclusion or limitation of incidental or consequential damages, so the above limitations or exclusions may not apply to you.

Customers located outside the US should consult their local, provincial or national legal codes for additional terms, which may apply to this warranty.

How to Obtain Warranty Service:

Customers should contact the authorized selling dealer to obtain warranty service. In the event the authorized selling dealer is unable to provide warranty service, please contact FPI by mail at the address listed below. Please include a brief description of the problem and your address, email and telephone contact information. A representative will contact you to make arrangements for an inspection and/or warranty service.

Canadian Warrantor:**FPI Fireplace Products International Ltd.**

6988 Venture St.
Delta, British Columbia
Canada, V4G 1H4

U.S. Warrantor:**Fireplace Products US, Inc.**

PO Box 2189 PMB 125
Blaine, WA
United States, 98231

Or contact the Regency Customer Care Centre at 1-800-442-7432 (phone) / 604-946-4349 (fax)
/customerservice@regency-fire.com (e-mail)

Product Registration and Customer Support:

Thank you for choosing a Regency Fireplace. Regency strives to be a world leader in the design, manufacture, and marketing of hearth products. To provide the best support for your product, we request that you complete a product registration form at <http://www.regency-fire.com/Customer-Care/Warranty-Registration.aspx> within **ninety (90)** days of purchase.

Warranty Registration Card



Product Registration and Customer Support:

Thank you for choosing a Regency Fireplace. Regency strives to be a world leader in the design, manufacture, and marketing of hearth products. To provide the best support for your product, we request that you complete a product registration form found on our Web Site under Customer Care within ninety (90) days of purchase.

For purchases made in **CANADA or the UNITED STATES:**

<http://www.regency-fire.com/Customer-Care/Warranty-Registration.aspx>

For purchases made in AUSTRALIA:

<http://www.regency-fire.com.au/Customer-Care/Warranty-Registration.aspx>

You may also complete the warranty registration form below to register your Regency Fireplace Product and mail and/or fax it back to us, and we will register the warranty for you. It is important you provide us with all the information below in order for us to serve you better.

Warranty Registration Form (or Register online immediately at the above Web Site):

Warranty Details	
Serial Number (required):	
Purchase Date (required) (mm/dd/yyyy):	
Product Details	
Product Model (required):	
Dealer Details	
Dealer Name (required):	
Dealer Address:	
Dealer Phone #:	
Installer:	
Date Installed (mm/dd/yyyy):	
Your Contact Details (required)	
Name:	
Address:	
Phone:	
Email:	

For purchases made in CANADA:

FPI Fireplace Products International Ltd.
6988 Venture St.
Delta, British Columbia
Canada, V4G 1H4

Phone: 604-946-5155
Fax: 1-866-393-2806

For purchases made in the UNITED STATES:

Fireplace Products US, Inc.
PO Box 2189 PMB 125
Blaine, WA
United States, 98231

Phone: 604-946-5155
Fax: 1-866-393-2806

For purchases made in AUSTRALIA:

Fireplace Products Australia Pty Ltd
99 Colemans Road
Dandenong South, Vic.
Australia, 3175

Phone: +61 3 9799 7277
Fax: +61 3 9799 7822

For fireplace care and tips and answers to most common questions please visit our Customer Care section on our Web Site. Please feel free to contact your selling dealer if you have any questions about your Regency product.

recycling

PRODUCT LIFE CYCLE:

By recycling your used appliances, you divert waste from your local landfills and help the environment. You also reduce the need for raw materials to manufacture new products. Contact your local municipality for appliance recycling services, local recycling programs, or appliance removal services to ensure your Regency appliance components, and packaging are properly recycled.

Installer: Please complete the following information

Dealer Name & Address: _____

Installer: _____

Phone #: _____

Date Installed: _____

Serial #: _____



Liberty LRI4E



Horizon HRI4E