

# Owners & Installation

# Manual

## LISTINGS AND CODE APPROVALS

These gas appliances have been tested in accordance with AS/NZS 5263.0 & AS/NZS 5263.1.3 and have been certified by the Australian Gas Association for installation and operation as described in these Installation and Operating Instructions.

Your unit should be serviced annually by an authorised service person.



# Freestanding Gas Stove

Models: FG38NG2-BRA  
FG38LPG2-BRA



## PLEASE KEEP THESE INSTRUCTIONS FOR FUTURE REFERENCE

<p><b>WARNING:</b> Improper installation, adjustment, alteration, service or maintenance can cause injury or property damage. Refer to this manual. For assistance or additional information consult an authorized installer, service agency or the gas supplier.</p>	<p><b>FOR YOUR SAFETY</b> What to do if you smell gas:</p> <ul style="list-style-type: none"><li>● Do not try to light any appliance</li><li>● Do not touch any electrical switch: do not use any phone in your building.</li><li>● Immediately call your gas supplier from a neighbour's phone. Follow the gas supplier's instructions.</li><li>● If you cannot reach your gas supplier, call the fire department.</li></ul>
<p><b>FOR YOUR SAFETY</b> Do not store or use gasoline or other flammable vapours and liquids in the vicinity of this or any other appliance.</p>	
<p>Installation and service must be performed by an authorized installer, service agency or the gas supplier.</p>	

---

### **To the New Owner:**

Congratulations! You are the owner of a state-of-the-art Gas Stove by FPI FIREPLACE PRODUCTS INTERNATIONAL LTD. The Regency Gas Series of appliances has been designed to provide you with all the warmth and charm of a woodstove, at the flick of a switch.

The models FG38NG2-BRA, and FG38LPG2-BRA of this series has been approved by AGA for both safety and efficiency. As it also bears our own mark, it promises to provide you with economy, comfort and security for many trouble free years to follow. Please take a moment now to acquaint yourself with these instructions and the many features of your Regency Gas Stove.

## **PAIRING YOUR REMOTE CONTROL**

**The control box will only learn the remote ID codes during the first 30 seconds after power is applied and will ignore this special command from the remote afterward.**

To match the control box to the remote, follow the steps below:

1. Remove a battery from the remote handset.
2. Remove main power to the control box by turning off the isolation switch or switch on the GPO to the heater.
3. Wait 30 seconds (approx.)
4. Reconnect main power to the control box.
5. Immediately put the battery back in the remote & point the remote in the direction of the heater.
6. Press and hold the PROG and FAN buttons simultaneously. The letters "LC" will appear on the display indicating ID code transmission.
7. Release both buttons.
8. The display will revert to the normal off mode display. The heater should light - spark, burner, etc. - even though the remote screen says the heater is off.
9. Press the OFF button on the remote. The heater should turn off.
10. Wait approx. 30 seconds to turn the heater on again & check that all functions work - fan speed and flame height can be adjusted, etc.

Note: To view a step-by-step pairing video please visit  
[regency-fire.com.au/Customer-Care/Fireplace-Care-Videos](http://regency-fire.com.au/Customer-Care/Fireplace-Care-Videos)

Note: The remote control handset has a set of unique ID codes that is pre-programmed into its memory. This set of ID codes helps to differentiate one remote control handset from another; only the control box with a matching ID code will respond to a handset.



# DIMENSIONS

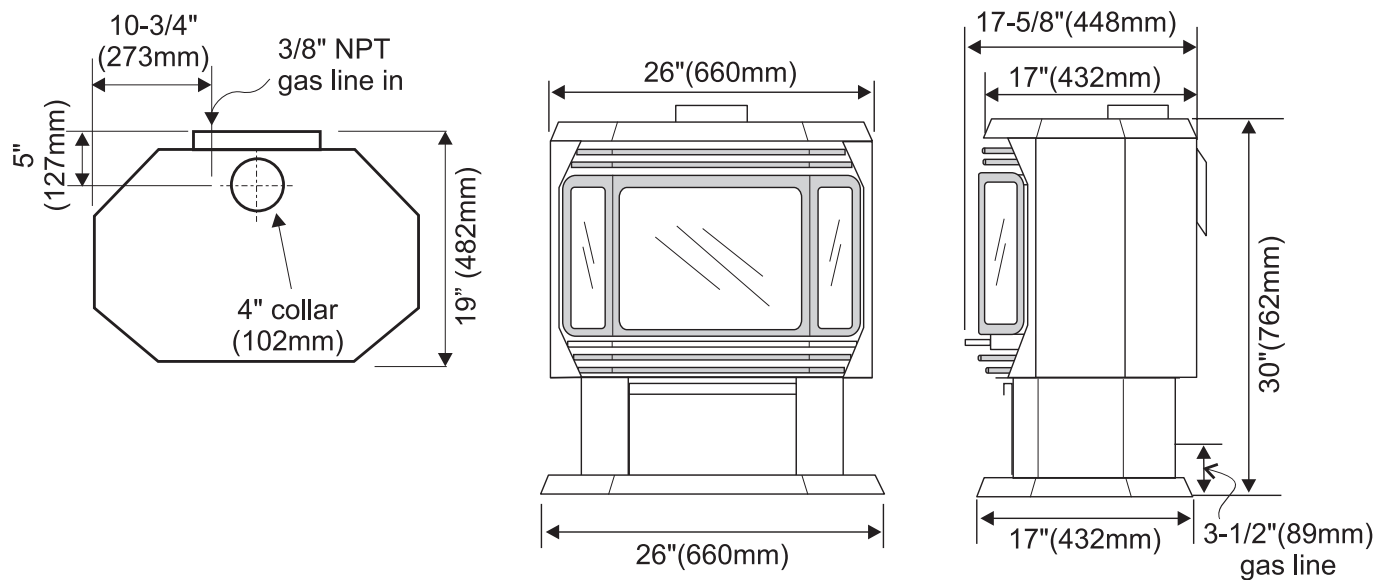

FG38NG2-BRA & FG38LPG2-BRA

# TABLE OF CONTENTS

---

## Safety Label

Paring Your Remote Control.....	2
Dimensions.....	3
Safety Label.....	5

## Installation

General Information.....	6
Before you start .....	6
General Safety Information.....	6
Installation Checklist.....	7
Clearances to Combustibles.....	7
Draft diverter.....	7
Flueing.....	7
Flueing Requirements .....	7
Gas Connection.....	8
Gas Pressure Testing .....	8
S.I.T. Valve Description.....	8
System Data .....	8
Conversion from NG to LPG.....	9
Aeration Adjustment .....	10
Log Installation .....	10
Front Door Installation .....	12
Test for Flue Spillage.....	12
Remote Control (optional) .....	13
Final Check.....	13
Wiring Diagram.....	13

## Operating Instructions

First Fire .....	14
Operating Instructions .....	14
Lighting Instructions.....	14
Shutdown Instructions .....	14
Fan Operation.....	14
Adjusting Flame Height .....	15
Summary of Controls.....	15
Normal Operating Sounds of Gas Appliances .....	15
Copy of Lighting Plate Instructions .....	16

## Maintenance

Maintenance Instructions.....	17
Log Replacement .....	17
Door and Glass Gasket .....	17
Glass Replacement .....	17
Fan Maintenance.....	18
Removing Valve.....	19
Gas Appliance Maintenance.....	20

## Parts List

Electronic Components .....	21
Main Assembly .....	22
Burner & Log Assembly .....	23
Door Assembly .....	24

## Warranty

Warranty .....	26
----------------	----

# SAFETY LABEL

This is a copy of the label that accompanies each Freestanding Gas Stove. We have printed a copy of the contents here for your review. The safety label is located on the inside of the drop down pedestal door.

**NOTE:** Regency units are constantly being improved. Check the label on the unit and if there is a difference, the label on the unit is the correct one.

## Regency Gas Fireplace

Model	<input type="radio"/>	<input type="radio"/>
Gas Type	NG	LPG
Model	FG38NG2-BRA	FG38LPG2-BRA
Gas Consumption High	34 MJ/h	31 MJ/h
Gas Consumption Low	20.8 MJ/h	16.1 MJ/h
Min. Supply Pressure	1.13 kPa	2.75 kPa
Manifold Pressure High	0.80 kPa	2.65 kPa
Manifold Pressure Low	0.23 kPa	0.94 kPa
Injector Size	1 x #33	1 x #52
Approval No. AGA 6231 G	2.87mm	1.61mm
Code AS/NZS 5263.0 & AS/NZS 5263.1.3		

**Electrical: 240VAC 50Hz 1.0 amp max.**

 **N2134**

Serial Number **257**

919-988

Distributed by:

Western Australia:

**Air Group Australia**  
28 Division St  
Welshpool WA 6106

Eastern Australia:

**Fireplace Products**  
Australia Pty. Ltd.  
1 Conquest Way  
Hallam, VIC 3803

To be installed by an authorised person in accordance with installation instructions provided with the appliance.



**DO NOT OPERATE THIS APPLIANCE BEFORE READING THE INSTRUCTIONS BOOKLET.**

**DO NOT PLACE ARTICLES ON OR AGAINST THIS APPLIANCE**

**DO NOT STORE CHEMICALS OR FLAMMABLE MATERIALS NEAR THIS APPLIANCE.**

**DO NOT OPERATE WITH PANELS, COVERS OR GUARDS REMOVED FROM THIS APPLIANCE.**

908-602c

**THE GUARD IS FITTED TO THIS APPLIANCE TO REDUCE THE RISK OF FIRE OR INJURY FROM BURNS AND NO PART OF IT SHOULD BE PERMANENTLY REMOVED.**

**FOR PROTECTION OF YOUNG CHILDREN OR THE INFIRM, A SECONDARY GUARD IS REQUIRED.**

## GENERAL INFORMATION

This installation must conform with local codes or, in the absence of local codes, with AS/NZ5601.



*THIS APPLIANCE SHOULD BE INSTALLED, REPAIRED, INSPECTED BEFORE USE AND CLEANED ANNUALLY BY AN AUTHORISED SERVICE PERSON. MORE FREQUENT CLEANING MAY BE REQUIRED, DUE TO EXCESSIVE LINT FROM CARPETING, ETC. IT IS IMPERATIVE THAT CONTROL COMPARTMENT, BURNERS AND CIRCULATING AIR PASSAGEWAYS OF THE APPLIANCE BE KEPT CLEAN.*



*DUE TO HIGH TEMPERATURES, THE APPLIANCE SHOULD BE LOCATED OUT OF TRAFFIC AND AWAY FROM FURNITURE AND DRAPERIES.*



*THIS APPLIANCE CAN ONLY BE FLUED IN ACCORDANCE WITH AS/NZ5601 OR LOCAL CODES.*



*FAILURE TO INSTALL THIS APPLIANCE CORRECTLY MAY CAUSE A SERIOUS HOUSE FIRE.*

Provide adequate clearances for servicing, proper operation and around the air openings into the combustion chamber. Adequate combustion and ventilation air must also be provided.

The appliance must be installed on a flat, solid, continuous surface (i.e. wood, metal, concrete). This may be the floor, or it can be raised up on a platform to enhance its visual impact.

The Regency Freestanding Gas Heater can be installed in a wide variety of ways and will fit nearly any room layout. It may be installed in a recessed position, framed out into the room, or across a corner.

We recommend that you plan your installation on paper using exact measurements for clearances and floor protection before actually installing this appliance. If an existing chimney is not utilised, position the appliance to allow free passage of factory-built listed chimney through the ceiling and roof.

## IMPORTANT:

The FG38 Freestanding Gas Stove must be installed in accordance with these instructions. Carefully read all the instructions in this manual first. Consult the "authority having jurisdiction" to determine the need for a permit prior to starting the installation.

## BEFORE YOU START

**INSTALLATION AND REPAIR SHOULD BE DONE BY AN AUTHORISED SERVICE PERSON. THE APPLIANCE SHOULD BE INSPECTED BEFORE USE AND CLEANED ANNUALLY BY AN AUTHORISED SERVICE PERSON. MORE FREQUENT CLEANING MAY BE REQUIRED DUE TO EXCESSIVE LINT FROM CARPETING, BEDDING MATERIAL, ETC. IT IS IMPERATIVE THAT CONTROL COMPARTMENTS, BURNERS AND CIRCULATING AIR PASSAGEWAYS OF THE APPLIANCE BE KEPT CLEAN.**

**DUE TO HIGH TEMPERATURES, THE APPLIANCE SHOULD BE LOCATED OUT OF TRAFFIC AND AWAY FROM FURNITURE AND DRAPERIES.**

**WARNING: FAILURE TO INSTALL THIS APPLIANCE CORRECTLY MAY CAUSE A SERIOUS HOUSE FIRE AND WILL VOID YOUR WARRANTY.**

**CHILDREN AND ADULTS SHOULD BE ALERTED TO THE HAZARDS OF HIGH SURFACE TEMPERATURES, ESPECIALLY THE FIREPLACE GLASS, AND SHOULD STAY AWAY TO AVOID BURNS OR CLOTHING IGNITION.**

**YOUNG CHILDREN SHOULD BE CAREFULLY SUPERVISED WHEN THEY ARE IN THE SAME ROOM AS THE APPLIANCE.**

**CLOTHING OR OTHER FLAMMABLE MATERIAL SHOULD NOT BE PLACED ON OR NEAR THE APPLIANCE.**

## GENERAL SAFETY INFORMATION

- 1) The appliance shall be installed in accordance with the manufacturer's installation instructions, local gas fitting regulations, municipal building codes, water supply regulations, electrical wiring regulations, with AS/NZ5601.
- 2) Installation and repair should be done ONLY by an authorised person.
- 3) See general construction and assembly instructions. The appliance should be inspected before use and at least annually by an authorised service person. More frequent cleaning may be required due to excessive lint from carpeting, bedding material, etc. It is imperative that control compartments, burners and circulating air passageways of the appliance be kept clean and free from excessive lint from carpeting.
- 4) This appliance must be connected to a flue and terminate to the outside of the building envelope. Never flue to another room.
- 5) Inspect the flueing system annually for blockage and any signs of deterioration.
- 6) Any safety glass removed for servicing must be replaced prior to operating the appliance.
- 7) To prevent injury, do not allow anyone who is unfamiliar with the operation to use the fireplace.
- 8) Wear gloves and safety glasses for protection while doing required maintenance.
- 9) Under no circumstances should this appliance be modified. Parts that have to be removed for servicing should be replaced prior to operating this appliance.
- 10) Installation and any repairs to this appliance should be done by an authorised service person. An authorised service person should be called to inspect this appliance annually. Make it a practice to have all of your gas appliances checked annually.
- 11) Do not strike the glass door.
- 12) Under no circumstances should any solid fuels (wood, paper, cardboard, coal, etc.) be used in this appliance.
- 13) The appliance area must be kept clear and free of combustible materials, (gases and other flammable vapours and liquids).
- 14) This unit can be installed on a solid com-

# INSTALLATION

bustible surface like a wood floor as well as on carpeting.

## INSTALLATION CHECKLIST

- 1) Check Clearances to Combustibles, page 6.
- 2) Install flueing, page 6.
- 3) Make gas connections, page 7.
- 4) If necessary, convert NG to LPG on page 8.
- 5) Test Gas Pressure, page 7.
- 6) Install log set where indicated on page 9.
- 7) Install Front Door, page 11.
- 8) Test for flue spillage (draft test), page 11.
- 9) Install Remote Control, page 12.
- 10) Final check, page 12.

Before leaving this unit with the customer, the installer must ensure that the appliance is firing correctly and operation fully explained to customer.

### This includes:

- 1) Clocking the appliance to ensure the correct firing rate (rate noted on label) after burning appliance for 15 minutes.
- 2) If required, adjusting the primary air to ensure that the flame does not carbon. First allow the unit to burn for 15-20 min. to stabilize.

**CAUTION:** Any alteration to the product that causes sooting or carboning or that results in damage is not the responsibility of the manufacturer.

## CLEARANCES TO COMBUSTIBLES

The clearances listed below are MINIMUM distances. Measure the clearance to both the appliance and the chimney connector. **(The farthest distance is correct if the two clearances do not coincide.)** For example, if the appliance is set as indicated in one of the figures but the connector is too close, move the stove until the correct clearance to the connector is obtained.

This unit can be installed on a solid combustable surface like a wood floor. This unit can also be installed directly on carpeting or vinyl when the bottom pedestal cover plate (provided with unit) is installed.

This appliance may be installed only with the clearances as shown in the situations pictured. Do not combine clearances from one type of installation with another in order to achieve closer clearances.

Use the minimum clearances shown in the diagrams below for all installations.

### FG38NG2-BRA & FG38LPG2-BRA Reference Dimensions

- C Back Wall to Flue Centerline 10-3/4" / 273 mm
- D Side Wall to Flue Centerline 20-1/2" / 520 mm
- F Side Wall to Flue Centerline 11" / 280 mm

### Clearances

- A Side Wall to Unit 7-1/2" / 190 mm
- B Back Wall to Unit 6" / 155 mm
- E Side Wall to Unit 2" / 50 mm

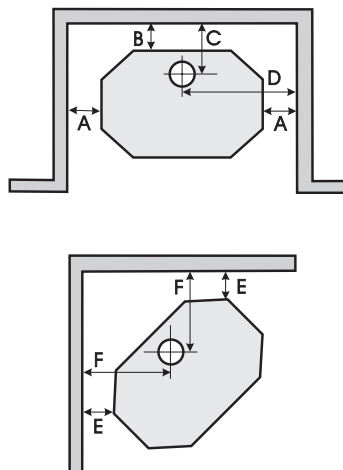

Minimum ceiling height is 36" / 914 mm from top of unit.

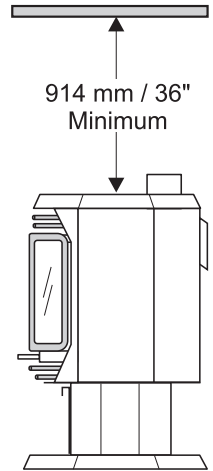

If further reduced clearances are needed, obtain requirements for construction of a protected wall from your local building authorities and their allowable reductions of the listed clearances.

## DRAFT DIVERTER

This heater has a draft diverter built in. It must not be altered, obstructed, or blocked in any way, and the unit must be installed so that the draft diverter is in the same atmospheric pressure zone as the combustion air inlet to the burner. This heater must be properly connected to a flueing system.

**WARNING:** Operation of this heater when not connected to a properly installed and maintained flueing system can result in carbon monoxide (CO) poisoning and possible death.

## FLUEING

This heater is a flued appliance and must be connected to a chimney/flue in accordance with the installation codes.

**Note:** The rear pedestal cover plate must always be fitted for safety. Electrical connections inside.

### Flueing Requirements

A100 mm diameter flue is required. For cosmetic or aesthetic purposes 6" outer flue can be used as long as an approved inner flue is installed. Fasten but do not penetrate the inner sleeve of the flue when tightening the screw.

The minimum flue required is 3.3m from floor level.

Follow all flueing manufacturer's requirements and local building codes or AS/NZ5601.



# INSTALLATION

## GAS CONNECTION

The gas line should be rigid pipe. Copper may also be used if approved by AS/NZ5601.

The gas connection at the valve is 1/2 male. For minimum and maximum supply pressure see the System Data Table.

## GAS PIPE PRESSURE TESTING

The appliance must be isolated from the gas supply piping system by closing its individual manual shut-off valve during any pressure testing of the gas supply piping system at test pressures equal to or less than 1/2 psig. (3.45 kPa). Disconnect piping from valve at pressures over 3.45 kPa (14" w.c.).

The manifold pressure is controlled by a regulator built into the gas control, and should be checked at the pressure test point.

**Note:** *To properly check gas pressure, both inlet and manifold pressures should be checked using the valve pressure ports on the valve.*

- 1) Make sure the valve is in the "OFF" position.
- 2) Loosen the "IN" (# 3) and/or "OUT" (# 4) pressure tap(s), turning counterclockwise with a 1/8" wide flat screwdriver.
- 3) Attach manometer to "IN" and/or "OUT" pressure tap(s) using a 5/16" ID hose.
- 4) Seal and or check the pilot outlet (# 8)
- 5) The pressure check should be carried out with the unit burning and the setting should be within the limits specified on the safety label.
- 6) When finished reading manometer, turn off the gas valve, disconnect the hose and tighten the screw (clockwise) with a 1/8" flat screwdriver. *Screw should be snug, but do not over tighten.*

## S.I.T. Valve Description

- 1) On-Off Solenoid Valve EV1
- 2) On-Off Solenoid Valve EV2
- 3) Inlet Pressure Test Point
- 4) Outlet Pressure Test Point
- 5) Connection for Pressure Regulator / Combustion Chamber Compensation
- 6) Pressure Regulator for Minimum and Maximum Outlet Pressure
- 7) Gas Outlet Pressure Electric Modulator
- 8) Pilot Outlet
- 9) Main Gas Outlet
- 10) Side Outlet
- 11) Main Gas Inlet

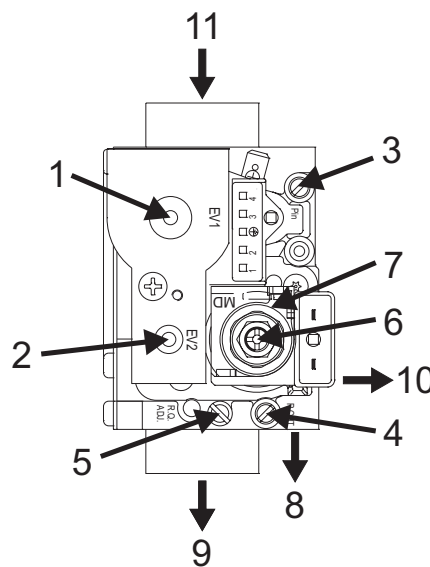

System Data FG38		
FG38NG2-BRA: For 0 to 610 meters altitude FG38LPG2-BRA: For 0 to 610 meters altitude		
Burner Inlet Orifice Sizes:		
Burner	NG #33	LPG #52
<b>Max. Input</b>		
	NG	34 MJ/h
	LPG	31 MJ/h
<b>Min. Input</b>		
	NG	20.8 MJ/h
	LPG	16.1 MJ/h
<b>Supply Pressure</b>		
	NG	1.13 kPa
	LPG	2.75 kPa
<b>Manifold Pressure</b>		
	NG	0.80 kPa
	LPG	2.65 kPa
Electrical: 240 V. 50Hz. Circulation: High/Off/LO speed fan, 150/89 CFM. Log Set: Ceramic fiber, 7 per set.		
<b>Aeration Setting</b>		
NG	15 mm open (fully open)	
LPG	15 mm open (fully open)	
<b>Flue Restrictor Setting</b>		
NG	Fully Open	
LPG	Fully Open	



# INSTALLATION

## Conversion Kit for NG to LPG Model #756-969

**THIS CONVERSION MUST BE DONE BY A QUALIFIED GAS FITTER IF IN DOUBT DO NOT DO THIS CONVERSION !!**

Conversion Kit 756-969 Contains:

Qty.	Part #	Description
1	904-390	Burner Orifice #52
1	919-728	Orange "Propane" label
1	908-255	Label "Converted to LPG"
1	918-270	Instruction Sheet

- 1) Shut off the gas supply and unplug the power cord.
- 2) Open the front door and carefully remove the logs and lava rock.
- 3) Remove burner.
- 4) Remove burner orifice with a 1/2" wrench and discard. Use a wrench to hold on to the elbow behind the orifice.
- 5) Reinstall new burner orifice LPG stamped #52 and tighten.

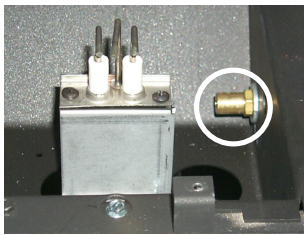

Burner Orifice

- 6) Adjust the burner aeration setting to 15mm before installing the burner. Reverse steps 3) and 2).
- 7) Stick the conversion label "This unit has been converted to LPG" over top of the serial number decal.
- 8) Replace the black "NG" label with the orange "Propane" label.

- 9) Remove the pedestal back cover by removing the 4 Phillips screws.

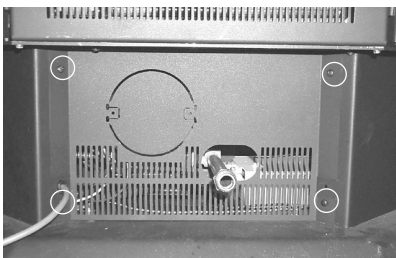

- 10) Carefully pull out the control box.

**NOTE:** The control box is held in place with velcro.

- 11) Remove the control box cover by undoing the 3 screws. Maneuver through antenna.

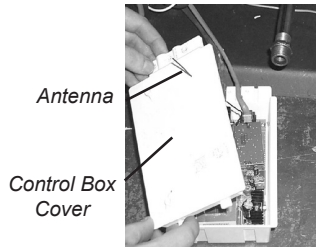

Antenna  
Control Box Cover

- 12) Remove the jumper using a plier.



Jumper Location

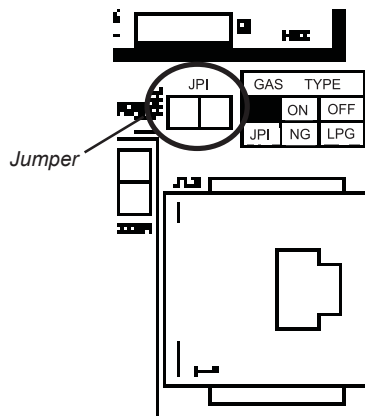

- 13) Reverse steps 11 to 9.

- 14) Turn on gas supply and plug in power cord.

- 15) **Adjusting the Outlet Pressure**

All the adjustments must be carried out in the following order:

Remove the modulator plastic cap (A) using needle nose pliers.

**Maximum pressure:** Turn the unit ON to its highest input rating. Screw in the nut (B) to increase the outlet pressure and screw it out to decrease it. Use a 10 mm wrench.

**NOTE:** The outlet pressure must be set to maximum 2.65 kPa.

**Minimum pressure:** Remove one of the cables connected to the electric modulator. Keeping the nut (B) blocked, screw in the screw (C) to increase the pressure and screw it out to decrease it. Use a screwdriver 6 x 1 blade.

**NOTE:** The outlet pressure must be set to minimum 0.74 kPa.

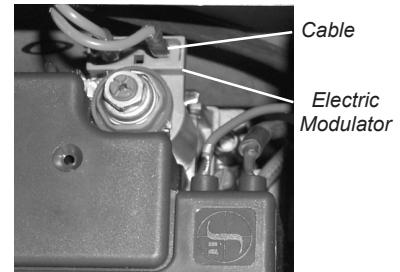

After carrying out all adjustments, block the setting screws with paint, taking care not to obstruct the breather orifice of the pressure.

Put back the modulator plastic cap.

**WARNING:** To ensure the correct operation of the modulator it is necessary that the plastic cap (A) is returned to its original location.

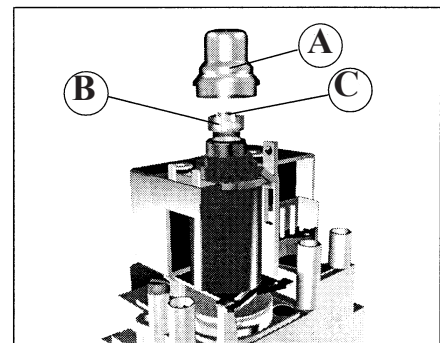

- 16) At the end of all setting and adjustment operations, check electrical insulation and gas leaks.

- 17) Check operation of flame control.

- 18) Check for proper flame appearance and glow on logs.

**Installer Notice:**  
These instructions must be left with the appliance.

# INSTALLATION

## AERATION ADJUSTMENT

The burner aeration is factory set but may need adjusting due to either the local gas supply or altitude.

**FG38 with 34 MJ/h NG  
FG38 with 31 MJ/h LPG**

FG38NG2-BRA 15 mm Fully Open  
FG38LPG2-BRA 15 mm Fully Open

**Caution: Carbon will be produced if the air shutter is closed too much.**

**Note: Any damage due to carboning resulting from improperly setting the aeration controls is NOT covered under warranty.**

## LOG SET INSTALLATION

**Read the instructions below carefully and refer to the diagrams. If logs are broken do not use the unit until they are replaced. Broken logs can interfere with the pilot operation.**

The gas log kit contains the following:

- a) 02-65 Rear Log
- b) 02-56 Middle Left Log
- c) 02-44 Front Left Log
- d) 02-46 Left Top Log
- e) 02-45 Front Right Log
- f) 02-47 Center Log
- g) 02-48 Middle Right Log
- h) Embers
- i) Lava

**Note: Install Optional Brick Panels prior to installing logs.**

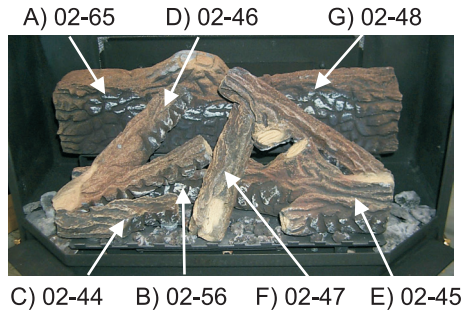

*The "02" refer numbers (i.e. 02-65) are molded into the rear of each log.*

- 1) Carefully remove the logs from the box and unwrap them. The logs are fragile, handle with care - **do not force into position.**
- 2) Sprinkle the embers on the left and right sides of the firebox base.

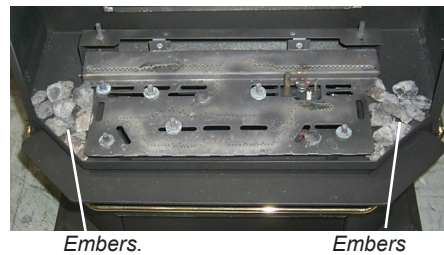

- 3) Place Rear Log A)02-65 on the two pins on the rear log support.



*Pins on Rear Log Support*

- 4) Place the Middle Left Log B)02-56 on the two pins as shown.



- 5) Sprinkle some lava rock just in front of B) 02-56 on the burner holes.

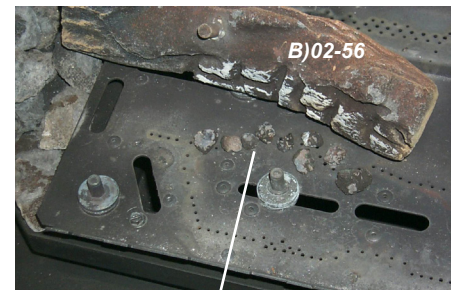

*lava rock*

- 6) Place Front Left Log C)02-44 onto the 2 front pins as shown.





# INSTALLATION

- 7) Place the Left Top Log D)02-46 on the pin on Log B)02-56 and on top of the cutout on Log A)02-65.

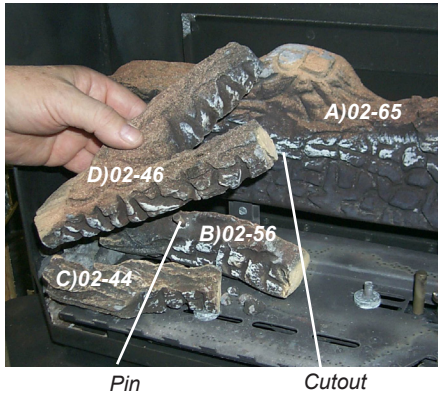

- 8) Place Front Right Log E)02-45 on the two pins as shown.



- 9) Place the lava rock in the area between the left and right logs, leaving a space in the middle for log (F) 02-47.

- 10) Place the notch in Center Log F)02-47 over Log E)02-45 and across the cutout on Log A)02-65.

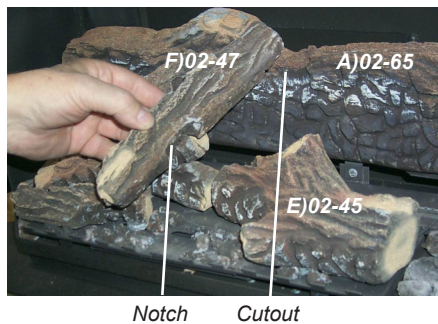

- 11) Position notch in Front Right Log G)02-48 on Log F)02-47 and push the bottom right edge against the bracket on the burner tray.

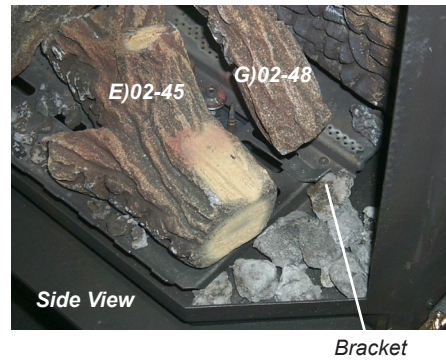
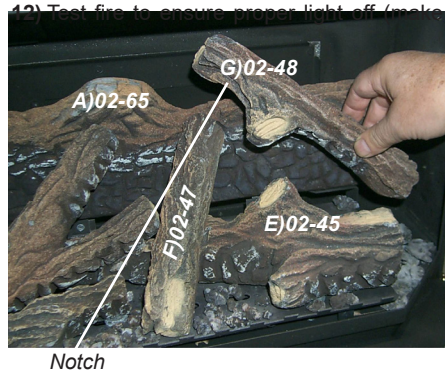

*The bottom right edge of Log G)02-48 must sit snugly against the bracket*

sure flame flows smoothly from one end of burner to the other. If there is any flame hesitation, check that area for any blockage of the burner port.



## FRONT DOOR INSTALLATION

- 1) Open the two side panels.
- 2) Slide the door onto the two hinge pins making sure the two pieces are flush together. See diagram 1.

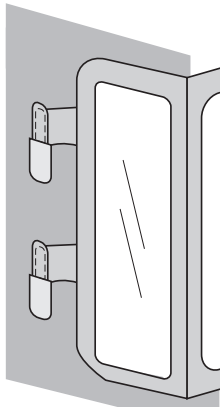

Diagram 1

**Note:** The door latch may require adjustment as the door gasket material compresses after a few fires and after glass replacement. Turn the latch catch inward or outward to loosen or tighten. Attach safety bracket with one screw as shown below.

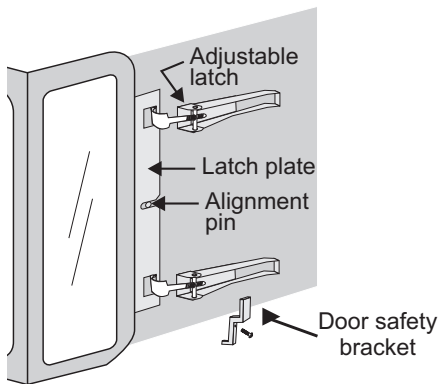

Diagram 2

- 3) Close the door. The latch plate must be centered around the alignment pin. See diagram 2. If the latch plate interferes with the corner of the stove you may want to angle the plate slightly so the door closes easier.

- 4) The latches should already be at the proper setting. If they are too hard or too easy to close, you may want to adjust them by loosening the latch catch. See diagram 3.
- 5) Test the seal around the door by placing a piece of paper between the unit and the door, close the door and try to pull the paper out. If it slips out easily, then the door is not properly sealed. Tighten or loosen the latch. See diagram 3.

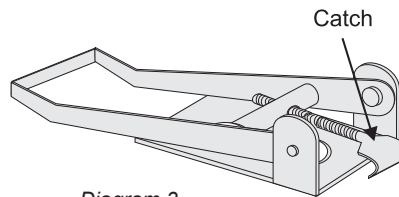
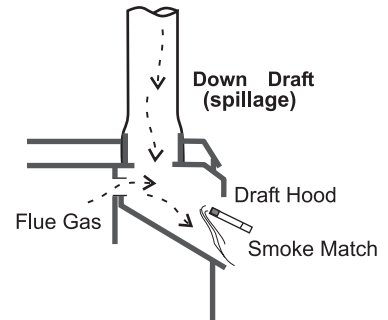

Diagram 3

The smoke should be drawn into the draft diverter. If the smoke is not drawn into the draft diverter, turn the unit off and check for the cause of lack of draft.



**Note:** If the flue is blocked or has a strong reverse flow, check for the cause of the lack of draft.

## TEST FOR FLUE SPILLAGE

A "spillage" test must be made before the installed unit is left with the customer. Follow the procedure below:

- 1) Start all exhaust fans in the home and any other gas appliances. Then close all doors and windows.
- 2) Light the unit and set controls to maximum.
- 3) After five minutes, test that there is a "pull" on the flue by placing a smoke match, cigarette or similar device which gives off smoke, on the edge of the draft diverter. See diagrams.

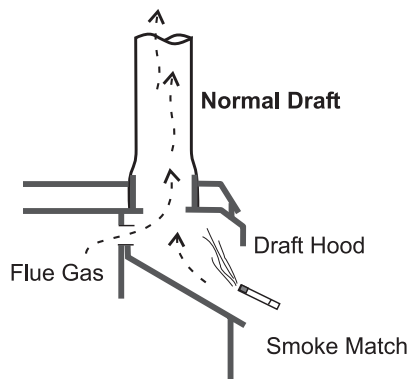
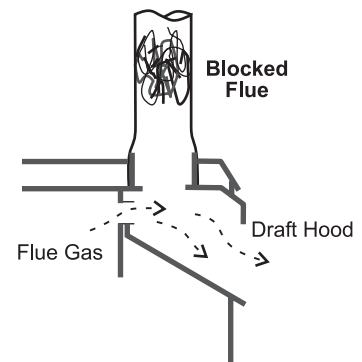

# INSTALLATION

## REMOTE CONTROL

Use the Regency Remote Control Kit approved for this unit. Use of other systems may void your warranty.

The remote control kit comes with a hand held transmitter and a wall mounting plate.

- 1) Choose a convenient location to mount the hand held transmitter, protection from extreme heat is very important.

By using the wall mounting plate to house the transmitter, the remote can also be used as a wall thermostat.



## FINAL CHECK

Before leaving this unit with the customer, the installer must ensure that the appliance is firing correctly. This includes:

- 1) Locking the appliance to ensure the correct firing rate (rate noted on label) at 15 minutes.
- 2) If required, adjusting the primary air to ensure that the flame does not carbon. First allow the unit to burn for 15 min. to stabilize.
- 3) Check for proper draft.

### CAUTION

Any alteration to the product that causes sooting or carboning that results in damage to the exterior fascia is not the responsibility of the manufacturer.

## WIRING

**Caution:** Ensure that the wires do not touch any hot surfaces and are away from sharp edges.

### WARNING: Electrical Grounding Instructions

This appliance is equipped with a three pronged (grounding) plug for your protection against shock hazard and should be plugged directly into a properly grounded three-prong receptacle. Do not cut or remove the grounding prong from this plug.

### CAUTION:

Label all wires prior to disconnection when servicing controls. Wiring errors can cause improper and dangerous operation.

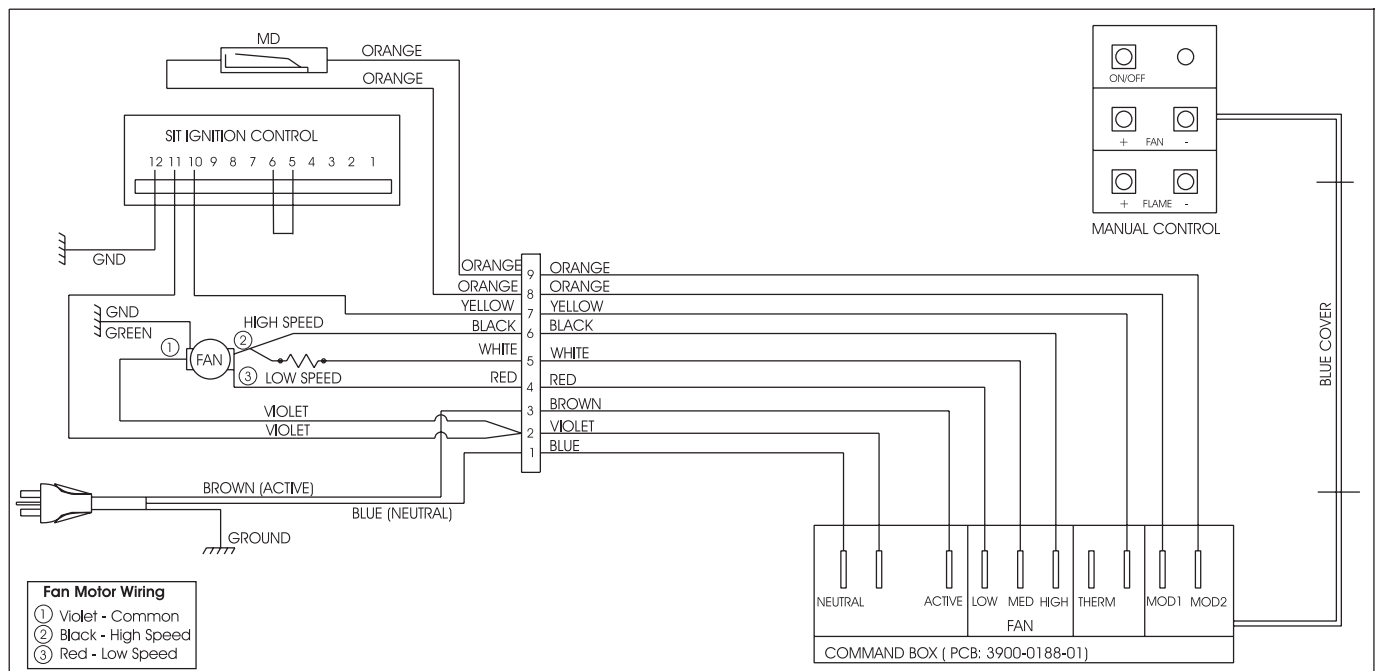

# OPERATING INSTRUCTIONS

## FIRST FIRE

The **FIRST FIRE** in your heater is part of the paint curing process. To ensure that the paint is properly cured, it is recommended that you burn your fireplace for at least four (4) hours the first time you use it with the fan on.

When first operated, the unit will release an odour caused by the curing of the paint and the burning off of any oils remaining from manufacturing. Smoke detectors in the house may go off at this time. Open a few windows to ventilate the room for a couple of hours. The glass may require cleaning.

**NOTE:** The main burner will always start on "HIGH" and resume it's last setting after 20 seconds of operation.

**NOTE:** When the glass is cold and the appliance is lit, it may cause condensation and fog the glass. This condensation is normal and will disappear in a few minutes as the glass heats up.

**DO NOT ATTEMPT TO CLEAN THE GLASS WHILE IT IS STILL HOT!**

**DO NOT BURN THE APPLIANCE WITHOUT THE GLASS FRONT IN PLACE.**

## OPERATING INSTRUCTIONS

Before operating this appliance, proceed through the following check list.

- 1) Read and understand these Instructions before operating this appliance.
- 2) Check to see that all wiring is correct and enclosed to prevent possible shock.
- 3) Check to ensure there are no gas leaks.
- 4) Make sure the three pieces of door glass are properly positioned. Never operate the appliance with any of the glass removed or with the door open.
- 5) Verify that all flueing and the cap is unobstructed.
- 6) Verify log placement.

## LIGHTING INSTRUCTIONS

- 1) Plug the power cord into a power outlet.
- 2) Press and release the ON/OFF switch once to start the unit. The LED will be lit.
- 3) After approximately 8 seconds the spark ignition system will spark for 8 seconds to light the main burner.
- 4) If the main burner does not light, repeat step 2 to restart unit.

### Caution:

If the appliance cannot be adjusted to perform correctly, shut off the gas supply, unplug the electrical connection to the unit, and then call a certified technician for service.

## FAN OPERATION

Set the fan speed on the control panel at the top rear of the unit to adjust to the desired speed.

Pressing and releasing the plus (+) FAN button will change the fan speed as follows:

OFF -> LOW -> MEDIUM -> HIGH -> OFF, etc.

Pressing and releasing the minus (-) FAN button will be the reverse of the above.

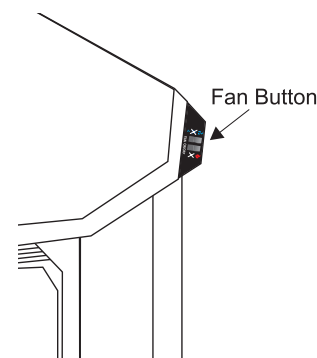

## SHUTDOWN INSTRUCTIONS

- 1) Press the ON/OFF switch once.
- 2) The LED will flash.
- 3) Turn off all electric power to the appliance if service is to be performed.



# OPERATING INSTRUCTIONS

## ADJUSTING FLAME HEIGHT

There are six flame settings that can be adjusted by pressing and releasing the plus (+) and minus (-) FLAME button.

The FLAME setting button is located on the control panel at the top rear of the unit.

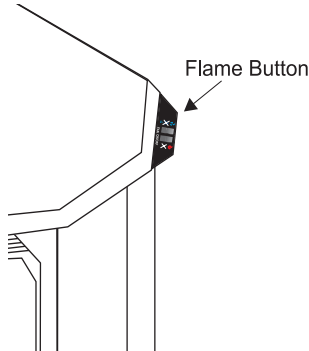

**WARNING**  
**DO NOT SPRAY AEROSOLS IN THE VICINITY OF THIS APPLIANCE WHILE IN OPERATION**

## SUMMARY OF CONTROLS

### **On/Off Button**

If the unit is switched off, pressing and releasing this button once will switch the unit on. The unit will resume its last settings.

If the unit is switched on, pressing and releasing this button once will switch the unit off.

### **Flame:**

**Increase** - If the unit is switched on, pressing and releasing the flame plus (+) button once will increase the flame height to the next available high setting.

**Decrease** - If the unit is switched on, pressing and releasing the flame minus (-) button once will decrease the flame height to the next available low setting.

### **Fan:**

**Increase** - If the unit is switched on, pressing and releasing the fan plus (+) button once will increase the fan speed to the next available high setting.

**Decrease** - If the unit is switched on, pressing and releasing the fan minus (-) button once will decrease the fan speed to the next available low setting.

## NORMAL OPERATING SOUNDS OF GAS APPLIANCES

It is possible that you will hear some sounds from your gas appliance. This is perfectly normal due to the fact that there are various gauges and types of steel used within your appliance. Listed below are some examples. All are **normal operating sounds** and should not be considered as defects in your appliance.

### **Blower:**

Regency gas appliances use high tech blowers to push heated air farther into the room. It is not unusual for the fan to make a "whirring" sound when ON. This sound will increase or decrease in volume depending on the speed setting of your fan speed control.

### **Burner Tray:**

The burner tray is positioned directly under the burner tube(s) and logs and is made of a different gauge material from the rest of the firebox and body. Therefore, the varying thicknesses of steel will expand and contract at slightly different rates which can cause "ticking" and "cracking" sounds. You should also be aware that as there are temperature changes within the unit these sounds will likely re-occur. Again, this is normal for steel fireboxes.

### **Gas Control Valve:**

As the gas control valve turns ON and OFF, a dull clicking sound may be audible, this is normal operation of a gas regulator or valve.

### **Unit Body/Firebox:**

Different types and thicknesses of steel will expand and contract at different rates resulting in some "cracking" and "ticking" sounds will be heard throughout the cycling process.

**WARNING**  
**DO NOT PLACE ARTICLES ON OR AGAINST THIS APPLIANCE.**

**WARNING**  
**DO NOT MODIFY THIS APPLIANCE**



# OPERATING INSTRUCTIONS

## COPY OF THE LIGHTING PLATE INSTRUCTIONS

### FOR YOUR SAFETY READ BEFORE LIGHTING

#### SUITABLE ONLY FOR INDOOR INSTALLATION

This appliance must be installed in accordance with local codes, if any; if not, follow the current CAN1-B149/ANSI Z 223.1 AS / NZS 5601

**WARNING:** If you do not follow these instructions exactly, a fire or explosion may result causing property damage, personal injury or loss of life. Improper installation, adjustment, alteration, service or maintenance can cause injury or property damage. Refer to the owner's information manual provided with this appliance. For assistance or additional information consult a qualified installer, service agency or gas supplier.

A) BEFORE LIGHTING smell all around the appliance area for gas. Be sure to smell next to the floor because some gas is heavier than air and will settle on the floor.

B) Do not use this appliance if any part has been under water. Immediately call a qualified service technician to inspect the appliance and to replace any part of the control system and any gas control which has been under water.

#### WHAT TO DO IF YOU SMELL GAS

- Do not try to light any appliance
- Do not touch any electric switch, do not use any phone in your building
- Immediately call your gas supplier from a neighbors phone. Follow the gas supplier's instructions.
- If you cannot reach your gas supplier, call the fire department.

This appliance needs fresh air for safe operation and must be installed so there are provisions for adequate combustion and ventilation air.

**CAUTION:** Hot while in operation. Do not touch. Severe Burns may result. Due to high surface temperatures keep children, clothing and furniture, gasoline and other liquids having flammable vapors away. Keep burner and control compartment clean. See installation and operating instructions accompanying appliance.

### LIGHTING INSTRUCTIONS

STOP! Read the safety information above on this label.

- 1) Plug the power cord into a power outlet.
- 2) Press and release the ON/OFF switch once to start the unit. The LED will be lit.
- 3) After approximately 8 seconds the spark ignition system will spark for 8 seconds to light the main burner.
- 4) If the main burner does not light, repeat step 2 to restart.

### TO TURN OFF GAS APPLIANCE

- 1) Press the ON/OFF switch once.
- 2) The LED will flash.
- 3) Turn off all electric power to the unit if service is to be performed.

You may shut off the pilot during prolonged non use periods to conserve fuel.

**DO NOT REMOVE THIS INSTRUCTION PLATE**

918-247c

**WARNING:**  
DO NOT SPRAY AEROSOLS IN THE VICINITY OF  
THIS APPLIANCE WHILE IN OPERATION.

# MAINTENANCE

## MAINTENANCE INSTRUCTIONS

Any maintenance required accessing the glass door of the unit must be performed by an authorized service person.

- 1) Always unplug the power cord before cleaning. For relighting, refer to lighting instructions. Keep the burner and control compartment clean by brushing and vacuuming at least once a year. When cleaning the logs, use a soft clean brush as the logs are fragile and easily damaged.
- 2) Clean glass (never when unit is hot), appliance, louvres, and door with a damp cloth. Never use an abrasive cleaner. The gold louvres (and optional gold door) may be scratched if abrasives are used to clean them.

The heater is finished in a heat resistant paint and should only be refinished with heat resistant paint (not with wall paint). Regency uses StoveBright Paint - Metallic Black #6309.

- 3) Make a periodic check of burner for proper position and condition. Visually check the flame of the burner periodically, making sure the flames are steady; not lifting or floating. If there is a problem, call an authorized service person.
- 4) The appliance and flueing system must be inspected before use, and at least annually, by an authorized field service person, to ensure that the flow of combustion and ventilation air is not obstructed.

During the annual service call, the burners should be removed from the burner tray and cleaned. Replace the embers - do not block the burner ports.

- 5) Keep the area near the appliance clear and free from combustible materials, gasoline and other flammable vapours and liquids.

**WARNING: CHILDREN AND ADULTS SHOULD BE ALERTED TO THE HAZARDS OF HIGH SURFACE TEMPERATURE AND SHOULD STAY AWAY TO AVOID BURNS OR CLOTHING IGNITION. YOUNG CHILDREN SHOULD BE CAREFULLY SUPERVISED WHEN THEY ARE IN THE SAME ROOM AS THE APPLIANCE.**

**CAUTION: ANY SAFETY SCREEN OR GUARD REMOVED FOR SERVICING AN APPLIANCE MUST BE REPLACED PRIOR TO OPERATING THE APPLIANCE.**

**CLOTHING OR OTHER FLAMMABLE MATERIAL SHOULD NOT BE PLACED ON OR NEAR THE APPLIANCE.**

**DO NOT USE THIS APPLIANCE IF ANY PART HAS BEEN UNDER WATER. IMMEDIATELY CALL AN AUTHORIZED SERVICE TECHNICIAN TO INSPECT THE APPLIANCE AND TO REPLACE ANY PART OF CONTROL SYSTEM AND ANY GAS CONTROL WHICH HAS BEEN UNDER WATER.**

- 6) Verify proper operation after servicing.

## LOG REPLACEMENT

The unit should never be used with broken logs. Unplug the power cord and allow the unit to cool before opening door to carefully remove the logs. If for any reason a log should need replacement, you must use the proper replacement log. The position of these logs must be as shown in the diagram under Log Installation.

**Note:** *Improper positioning of logs may create carbon build-up and will alter the unit's performance which is not covered under warranty.*

## DOOR AND GLASS GASKET

If the door gasket requires replacement use 7/8" diameter oval door gasket (Part# 650-920). The glass requires 5/8" flat glass gasket. See your Regency dealer.

## GLASS REPLACEMENT

Your Regency heater is supplied with high temperature, 5mm Neoceram silica coated ceramic glass that will withstand the highest heat that your unit will produce. In the event that you break your glass, purchase your replacement from an authorized Regency dealer only, and follow the step-by-step instructions for replacement.

### Removing Glass:

**Note:** Wearing gloves will protect your hands while handling glass.

- 1) Remove the door from the unit and place on a soft surface to prevent scratching.
- 2) Pull out the door gasket.
- 3) Remove the 24 nuts holding the glass retainers in place. *Do not remove the nuts underneath the retainers.*
- 4) Remove the door catch plate.
- 5) Remove glass retainers on sides first (3 each side) then remove two center retainers.
- 6) Remove glass from door assembly. When removing glass, leave white insulation in place.
- 7) Reverse steps 6 - 2.

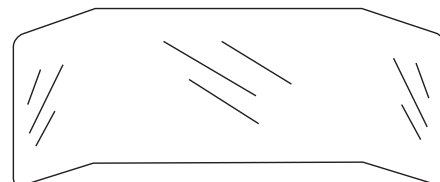
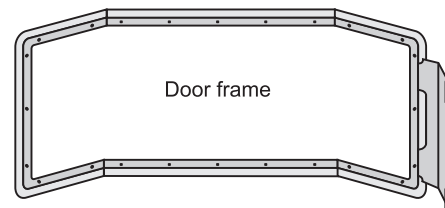
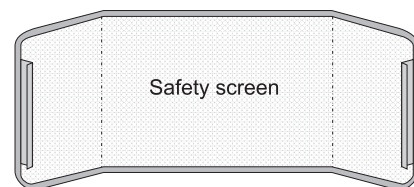

## Handling of Ceramic fiber log sets and brick panels

When installing or removing ceramic fiber log sets or ceramic brick panels (if installed) from an appliance we recommend that you use latex gloves and a P1 respiratory filter be used.

We also recommend if when servicing the appliance that any items which may be replaced, not be broken up and are sealed within a heavy duty polythene bag and labeled as RCF waste.

A vacuum with a HEPA filter should be used when cleaning up remaining dust or broken bits.

Protective clothing is not required when handling these articles.

RCF waste is classed as stable, nonhazardous waste which may be disposed of at any licensed landfill site.

## FAN MAINTENANCE

If your fan requires maintenance or replacement, access to the fan is through the access panel on the rear wall of the firebox.

If the unit is damaged or needs repair, it shall be repaired by the manufacturer or its service agent or similarly qualified person in order to avoid a hazard.

**Note:** The unit **MUST NOT** be operated without the fan access panel securely in place and correctly sealed.

**IMPORTANT**  
*Disconnect power supply  
before servicing*

**IMPORTANT:** These fans collect a lot of dust from within your home. Ensure you maintain these fan motors on a regular basis by vacuuming out the fan squirrel cages, around the motor, and around the grills on the back of the stove.

**WARNING:** Electrical Grounding Instructions This appliance is equipped with a three pronged (grounding) plug for your protection against shock hazard and should be plugged directly into a properly grounded three-prong receptacle. Do not cut or remove the grounding prong from this plug.

## To Remove FG38 Fan:

- 1) Unplug or disconnect power source to stove.
- 2) Remove all logs and the rear log support, then remove the 10 screws holding the access panel in place, see Diagram 1. (Fan is also accessible by opening the right side door. See Diagram 2).
- 3) Unclip the black, red and white wires from the fan motor.

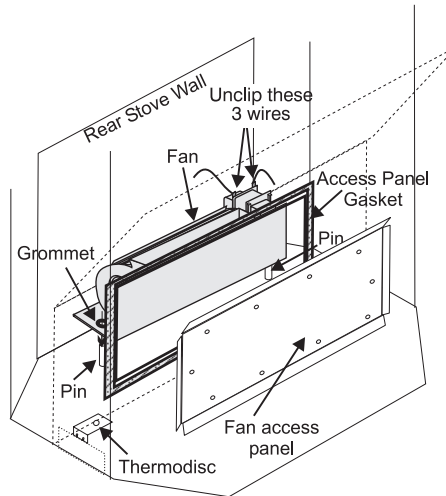

Diagram 1

- 4) Lift fan off of the 2 pins, tip back and pull through firebox opening. Disconnect the green ground wire from the left side of the fan as soon as you can reach it.

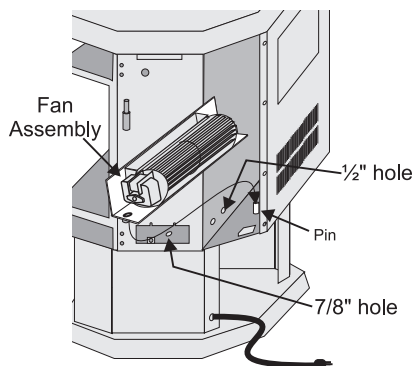

Diagram 2

## Replacing FG38 Fan:

Reverse the above steps (1 to 4). If necessary install a new gasket before replacing the fan access panel. Make sure the fan wires and the ground wire are reattached.

# MAINTENANCE

## REMOVING VALVE

If your valve requires maintenance or replacement, follow these instructions:

**NOTE: Always shut off the gas and disconnect the power supply before removing the valve.**

- 1) Open the front door and carefully remove the logs and lava rock.
- 2) Remove the burner by removing the two 1/4" hex head screws. See diagram below.
- 3) Open the front pedestal door and unhook

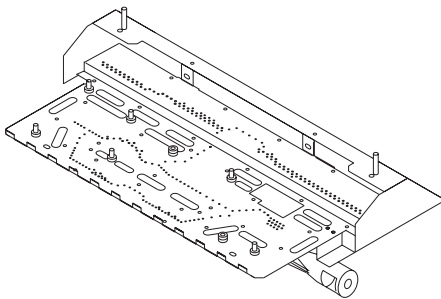

chain. You may want to put a soft cloth on the base of the unit so that when the pedestal door is open it doesn't scratch the paint. See diagram below.

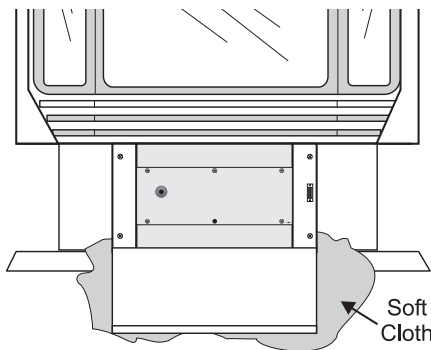

- 4) Remove the two outside frame pieces by removing two screws per side. See diagram below.

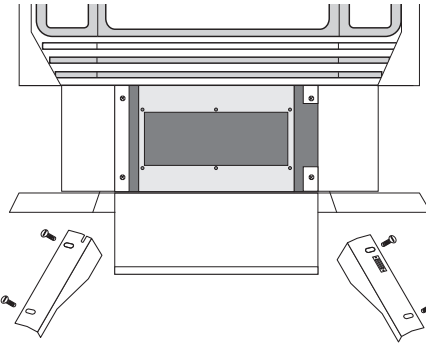

- 5) Open the side pedestal door by unscrewing the 2 Phillips screws.
- 6) Disconnect the valve wires from the 9 pin connector, located on the right side of the connector.

Valve wires consist of 2 orange, 1 yellow and 2 purple colored wires.

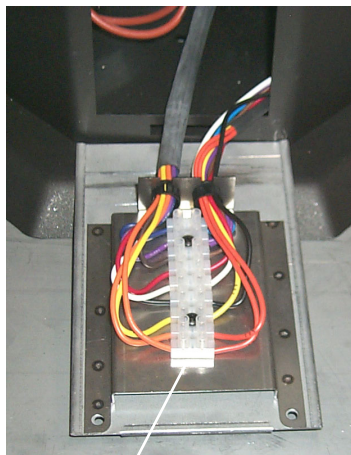

9 Pin Connector

- 7) At this point you should disconnect the gas at the valve.
- 8) Remove the pedestal back cover by removing the 4 Phillips screws.
- 9) Disconnect the ground wires.

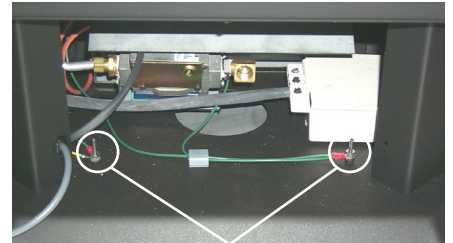

Ground Wires

- 10) Remove the eight 1/4" hex head screws holding the burner tray assembly in place.
- 11) Carefully lift the burner tray assembly out.

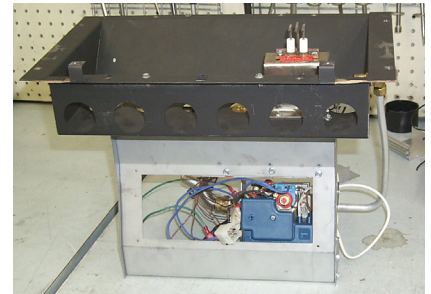

- 12) To replace the burner tray assembly, simply reverse these instructions.

## GAS APPLIANCE MAINTENANCE

In order for your Regency appliance to continue to provide comfort to your home periodic maintenance must be performed to ensure it is operating at peak efficiency. The items in the list should be checked by a licensed gas service technician during the annual service check. Your unit may require more frequent maintenance checks if you notice any changes in how it operates. Operational changes to look for can include, but are not limited to, extended start up time, increased fan noise, residue/carbon build up, white build up on the glass/firebox, increased operating noise etc. Should any of these or other conditions arise, discontinue use and schedule a service check with your local licensed gas technician. The list below shows items your licensed service technician will need to check and service at least annually.

### Clean

- Glass
- Interior bricks / panels
- Burner ports & burner air shutter
- Fan blades
- Log set
- Pilot orifices
- Pilot hood (change as needed)
- Flame sensor (electronic ignition models)
- Flame electrode
- Burner orifice
- Thermocouple (millivolt models)
- Thermopile (millivolt models)

### Inspect

- Pilot assembly
- Burner
- Pressure relief gaskets/doors
- Flue connector gasket if present
- Door seal
- Firebox
- Venting
- Batteries (remote handheld, remote receiver, DC sparker, change as needed)
- Burner media (change as needed)
- Air shutter setting
- Wiring

### Check

- Voltage on thermocouple/thermopile (millivolt models)
- Ohms reading on flame sense (electronic ignition models)
- Inlet/outlet fuel pressures as per rating plate
- Voltage/ohms readings on gas valve
- Ohms reading to on/off switch circuit (Millivolt models)

### Gas Leak Tests

- Check main gas line connection to valve
- Check shut off valve connections
- Check connection at gas valve outlet
- Check connection at main burner orifice
- Check pilot fuel line at valve and at pilot assembly



# PARTS LIST

## ELECTRONIC COMPONENTS PARTS LIST

**Note:** Depending on the model, the diagram below may not be exactly as shown - for reference purposes only.

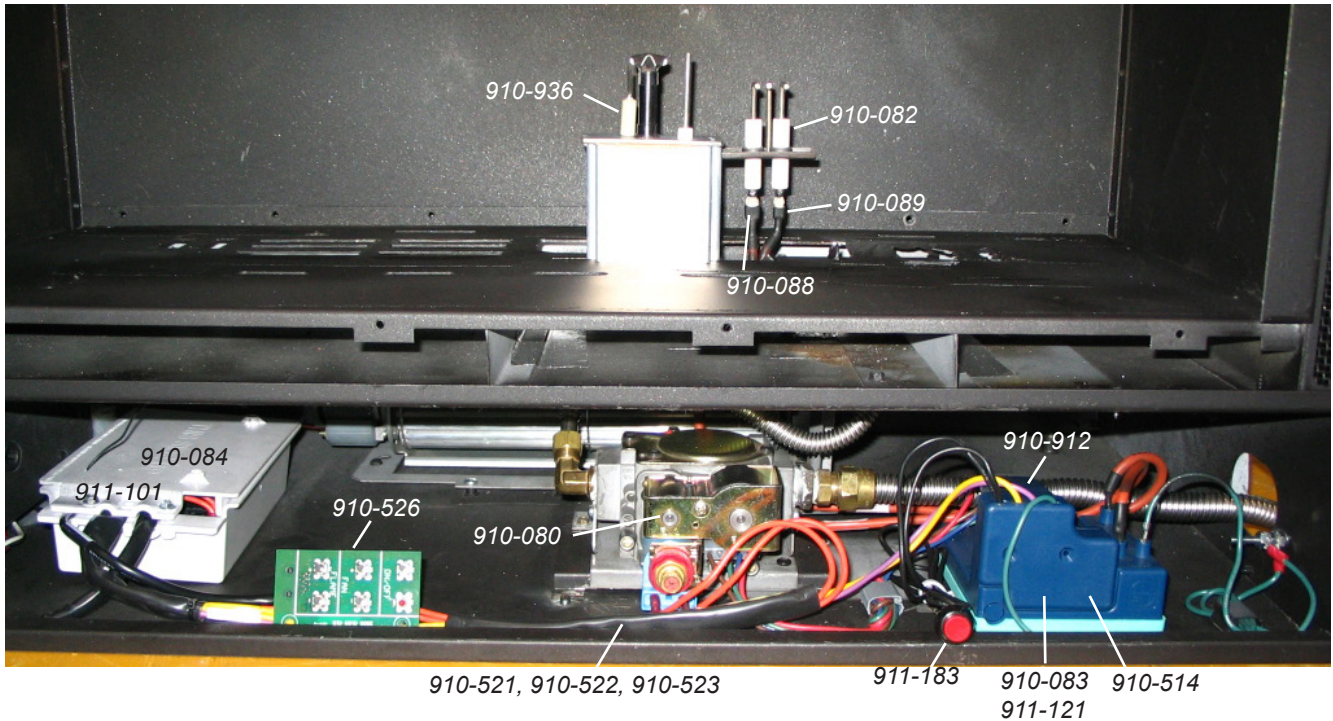

	FG38	FG39	PG33	PG36 / PG36D	PG121/ PG131	GFI300L	IG34	GF900L/C	GF1500L
<b>910-909</b> Fan Resistor	✓	✓	✓	✓	✓	✓	✓	✓	✓
<b>910-936</b> Intermittent Pilot	N/A	✓	✓	✓	✓	N/A	✓	✓	N/A
<b>911-146</b> Intermittent Pilot	N/A	N/A	N/A	N/A	N/A	✓	N/A	N/A	✓
<b>910-082</b> Direct Spark Ignitor	✓	N/A	N/A	N/A	N/A	N/A	N/A	N/A	N/A
<b>910-089</b> Flame Cable	✓	N/A	N/A	N/A	N/A	N/A	N/A	N/A	N/A
<b>910-088</b> Spark Cable	✓	N/A	N/A	N/A	N/A	N/A	N/A	N/A	N/A
<b>910-084</b> Control Box	✓	✓	✓	✓	✓	N/A	✓	N/A	N/A
<b>911-101</b> Control Box	N/A	N/A	N/A	N/A	N/A	✓	N/A	✓	✓
<b>910-527</b> Manual Control Switch	✓	✓	N/A	N/A	N/A	N/A	✓	N/A	N/A
<b>910-080</b> Valve	✓	✓	✓	✓	✓	✓	✓	✓	✓
<b>910-521</b> Control Box Cable (1)				(1)					
<b>910-522</b> Control Box Cable (2)	*N/A	(2)	(1)			N/A	(2)	N/A	N/A
<b>910-523</b> Control Box Cable (3)					(3)				
<b>910-525</b> Control Box Cable (4)									
<b>910-912</b> Ignition Module to Valve Cable	N/A	N/A	✓	✓	✓	✓	✓	✓	✓
<b>911-183</b> Reset Switch	N/A	✓	✓	✓	✓	✓	✓	✓	✓
<b>910-083</b> Ignition Module (1)	(1)								
<b>911-121</b> Ignition Module (2)	(2)	(2)	(2)	(2)	(2)	(2)	(2)	(2)	(2)
<b>910-514</b> Jumper Wire	N/A	✓	✓	✓	✓	✓			
<b>910-935</b> Manual Control Switch	N/A	N/A	✓	✓	✓	N/A	✓	N/A	N/A

**\*\*Note:** The Control Box Cable wires for the FG38 come separately: 910-502, 910-505, 910-506, 910-507, 910-509

# PARTS LIST

## MAIN ASSEMBLY

Part #	Description	Part #	Description
1) 560-920	Top / Bottom Gold Louvre (Set)	23) 904-258	Side Panel Door Magnet
560-922	Top / Bottom Black Louvre (Set)	24) 948-255	Door Latch c/w Hook
2) 750-532	Safety Screen (Australia only)	25) 750-095	Door Hold Down Bracket
9) 750-040	Fan Access Door	30) 750-026	Rear Panel
10) 750-074	Gasket for Fan Access Door	32) 730-028	Firebox Baffle
560-519/P	Fan Assembly	33) 560-535	False Top Assembly
11) 910-169/P	Fan Motor (240 Volt)	34) 590-273	Flue Attachment Bracket
12) 910-714	Power Cord (240 Volt)	35) 590-930	Ult. 6" Flue Collar (Optional)
15) *	Pedestal Assembly	38) 820-058F	Pedestal Base Cover
16) 730-039	Pedestal Door	46) 750-083	Rear Control Panel
17) 904-257	Pedestal Door Magnet	910-087	Switch Manual Control ECS c/w Wire Harness
18) 750-084	Pedestal Back	756-969	Conversion Kit - to LPG
19) 756-518	Side Panel Door Assy (Right Side)	948-216	Logo Plate
20) 756-520	Side Panel Door Assy (Left Side)	918-243	Manual
21) 560-031	Hinge for Side Panel		

\*Not available as a replacement part.

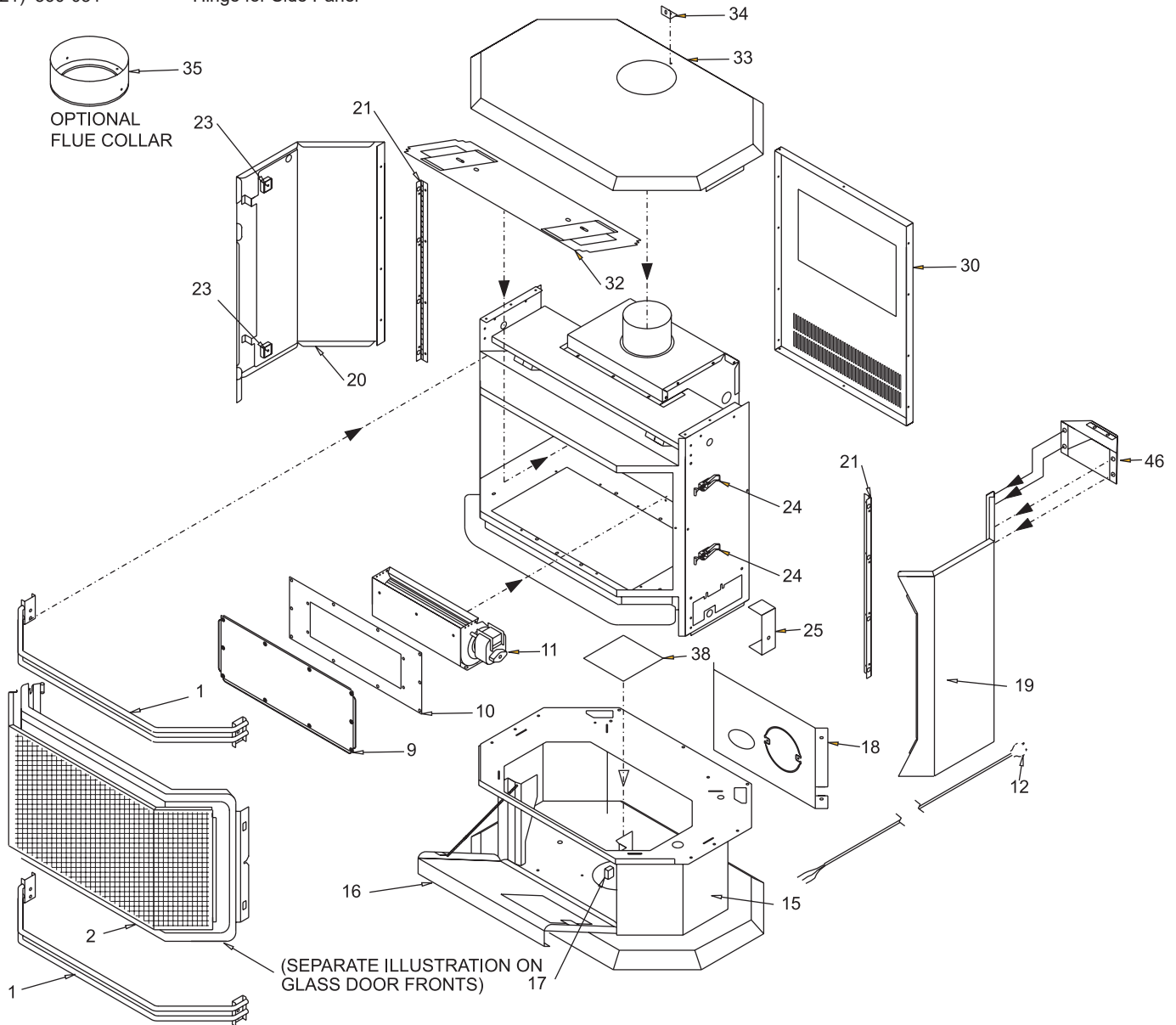



## BURNER & LOG ASSEMBLY

Part #	Description
756-527/P	Valve Assembly - NG
756-529/P	Valve Assembly - LPG
60) 910-080	Valve Sigma 845 - NG
910-081	Valve Sigma 845 - LPG
904-689	#33 Orifice - NG at 34 MJ/h
904-390	#52 Orifice - LPG at 31 MJ/h
71)	752-528 Rear Log Bracket Assy
72)	910-082 Ignition Direct Spark Assy. - NG/LPG
75)	732-930 Log Set
78)	752-525 Burner Assy - NG/LPG
910-083	Module Sit 230V
910-084	Control Box ECS
910-088	Wire ECS Module Spark (Red)
910-089	Wire ECS Module Flame (Red)
910-086	Remote Control - ECS (optional)

- 92) Rear Log
- 93) Left Top Log
- 94) Center Log
- 95) Middle Right Log
- 96) Middle Left Log
- 97) Front Right Log
- 98) Front Left Log

\*Not available as a replacement part.

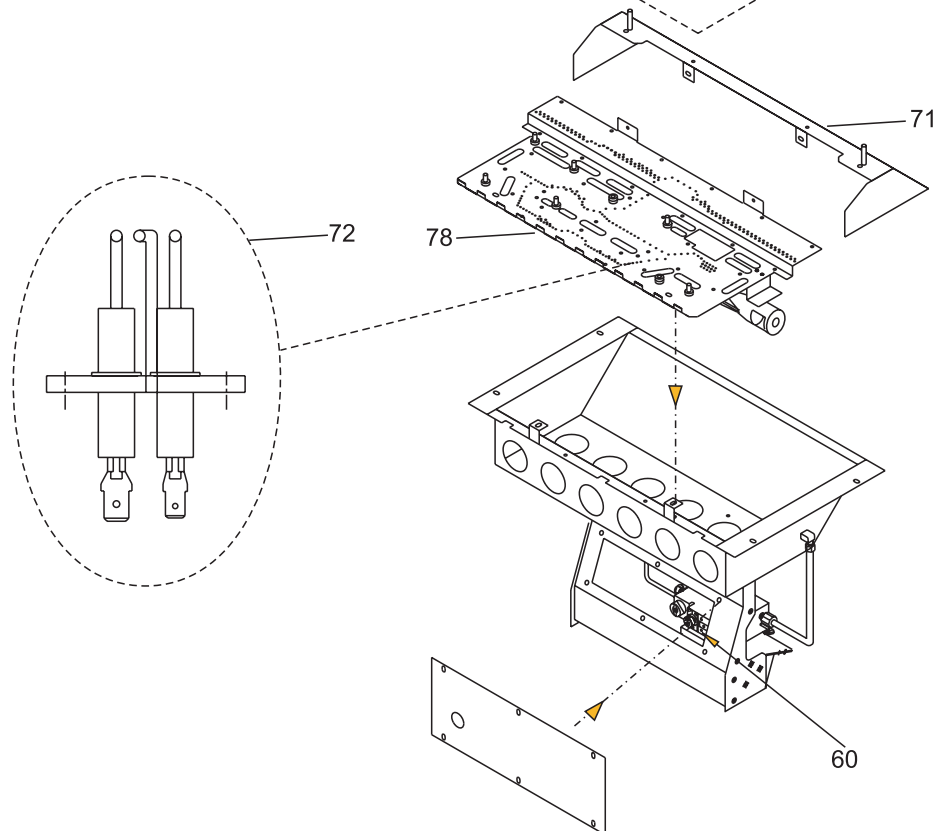
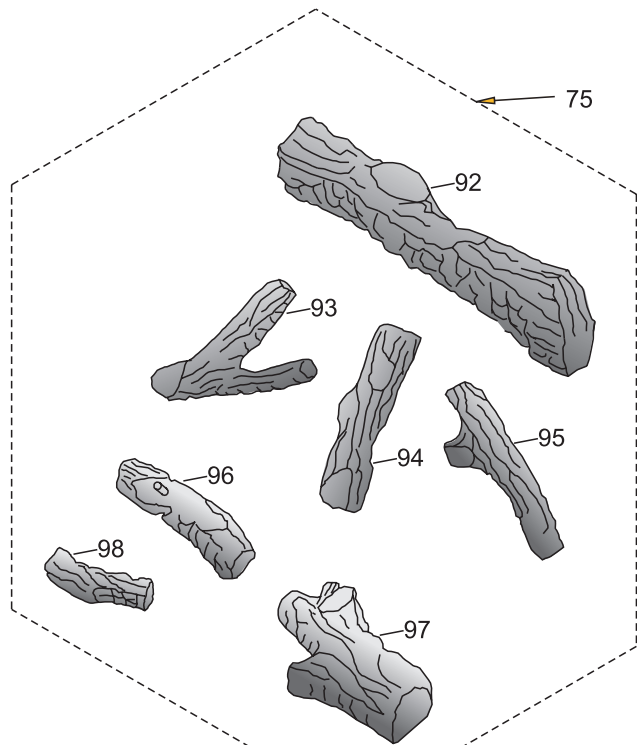

# PARTS LIST

## DOOR ASSEMBLY

Part #	Description
	732-943 Black Wrap Door - Complete
101)	732-570 Door Gasket Kit
105)	* Ceramic Paper
107)	936-243 Glass Gasket
111)	* Door Frame Fibre Paper
208)	940-325/P Wrap Glass

\*Not available as a replacement part.

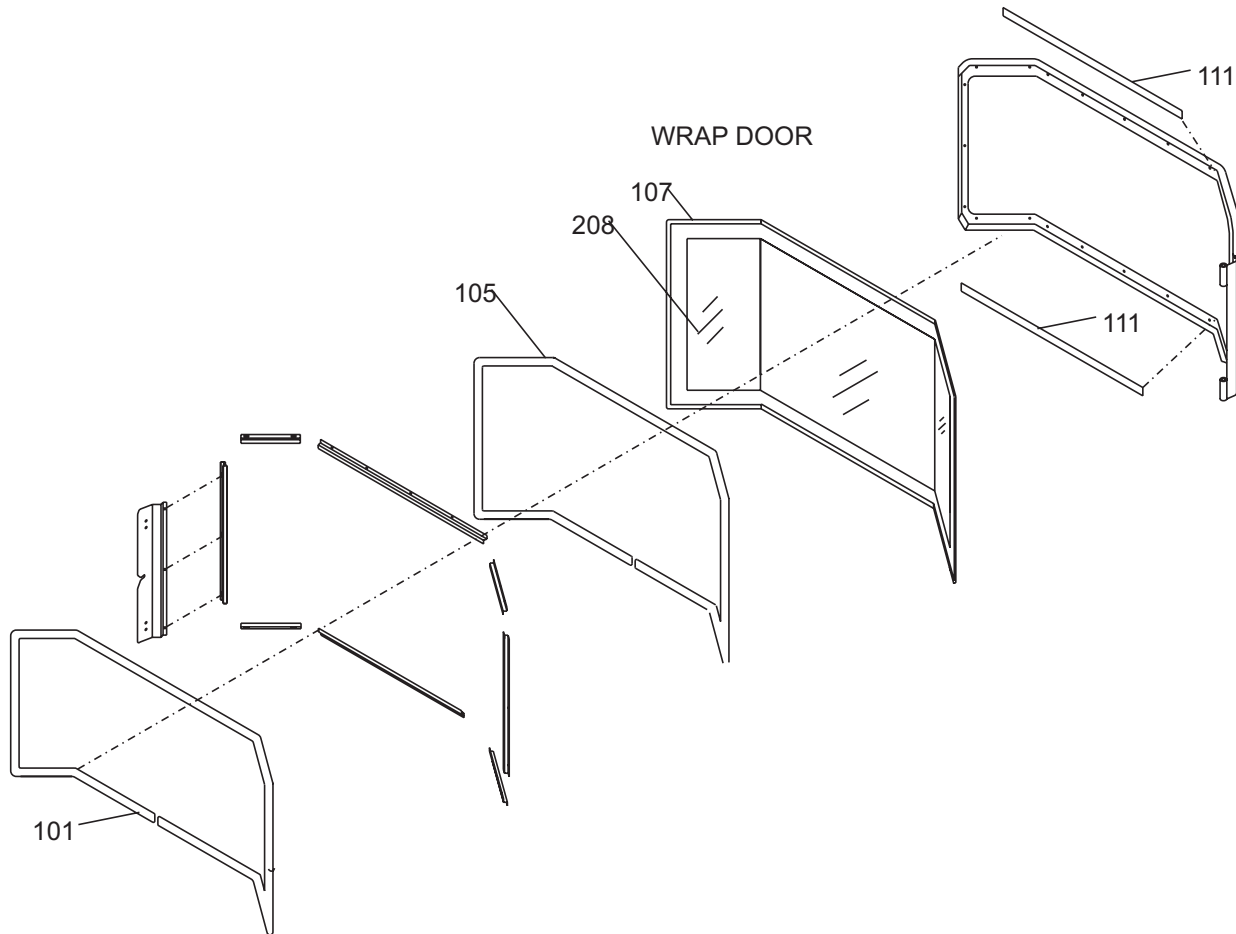



# WARRANTY

## Limited Lifetime Warranty

FPI Fireplace Products International Ltd. (“the manufacturer”) through its wholly owned subsidiary, Fireplace Products Australia Pty Ltd (for Australia and New Zealand customers) and sold under the Regency® brand of fireplace products (collectively referred to herein as “FPI”), extends this Limited Lifetime Warranty to the original purchaser of this appliance provided the product remains in the original place of installation. The items covered by this limited warranty and the period of such coverage is set forth in the table below.

Some conditions apply (see below).

The policy is not transferable, amendable or negotiable under any circumstances.

Indoor Gas Products Warranty Coverage Parts and Labor	Part				Supplier Warranty	Labor Coverage (Years)
	Lifetime	5 years	2 years	1 year		
Firebox and Heat Exchanger	✓					3
Steel Burner Tube	✓					3
Glass Thermal breakage only	✓					3
All Surrounds/Inlays Finishes		✓				3
Brick Panels/Log sets/Ceramic Burners		✓				3
All Castings		✓				3
Valve assembly and all gas control components (Pilot assembly, flame sensors, Spark Electrode, Pilot Tubing, Orifices, Thermocouple, Thermopile)			✓			2
All Other Electrical components (Ignition Control Boards, Wiring, Switches, Fans, Fan Control Module, Battery Pack, Remote Control Systems)			✓			1
Enamel Panels			✓			1
Venting/Venting Components			✓			1
All Stainless steel surrounds				✓		1
All Firebox Media (Crystals, Fire beads, Volcanic, Ceramic & Spa Stones)				✓		1
All hardware				✓		1
Mesh/Glass Safety Barriers				✓		1
Accent Light Bulbs				✓		1
Glass (Crazing)				✓		1

After the original warranty coverage for any of the parts above have expired, any repair and/or replacement parts purchased by the consumer from FPI or through an accredited distributor or dealer will carry a ninety (90) day warranty (valid only with an original copy of the tax invoice). No labor coverage is included with any repair and/or replacement part.

Replacement parts are limited to one per warranty term.

### Conditions:

Warranty protects against defect in manufacture or FPI factory assembled components only, unless herein specified otherwise. This warranty will only apply to those products which are acquired at the time of this warranty being effective. FPI will not be liable for any damage or loss that falls outside the scope of the warranty.

Any part(s) found to be defective during the warranty period as outlined above will be repaired or replaced at FPI’s option through an accredited distributor, dealer or pre-approved and assigned agent provided that the defective

part is returned to the distributor, dealer or agent for inspection if requested by FPI. Alternatively, FPI may at its own discretion fully discharge all of its obligations under the warranty by refunding the verified purchase price of the product to the original purchaser. The purchase price must be confirmed by an original copy of the tax invoice.

**The authorised selling dealer, or an alternative authorised FPI dealer if pre-approved by FPI, is responsible for all in-field diagnosis and service work related to all warranty claims. This warranty does not cover dealer travel costs for diagnostic or service work. Dealers may charge homeowner for travel and additional time. Check with your selling dealer in advance for any costs to you when arranging a warranty call. FPI is not responsible for results or costs of workmanship of unauthorised FPI dealers or agents in the negligence of their service work. Additional service fees may apply if you are seeking warranty service from a dealer other than the dealer from whom you originally purchased the product.**

At all times FPI reserves the right to inspect reported complaints on location in the field claimed to be defective and determine whether the warranty will apply prior to processing or authorising of any claim. Failure to allow this upon request will void the warranty.

All warranty claims must be submitted by the dealer servicing the claim, including an original copy of the tax invoice (proof of purchase by you). All claims must be complete and provide full details as requested by FPI to receive consideration for evaluation, including proof of maintenance records. Incomplete claims may be rejected. FPI has absolute discretion to assess and determine any warranty claim and may accept or reject a claim as it considers appropriate. Any part or parts of the unit found to be defective will be repaired or replaced at FPI's option, through an accredited distributor or service agent provided that the defective part be returned to the distributor or agent, **Transportation Prepaid**, if requested. **It is the general practice of FPI to charge for larger, higher priced replacement parts and issue credit once the replaced component has been returned to FPI and evaluated for manufacturer defect.**

**If a consumer has a unit installed outside an accredited distributor, dealer or pre-approved service agent's service area, or the closest approved service agent is situated more than thirty (30) kilometres from the installation, FPI is not obliged to arrange warranty repairs or shipping/transportation costs. In these cases, the consumer must arrange warranty service with its selling dealer, and shipping, travel and/or additional labor charges will apply.**

Unit must be installed according to all manufacturers' instructions as per the manual.

All Local and National required codes must be met.

The installer is responsible to ensure the unit is operating as designed at the time of installation.

The original purchaser is responsible for annual maintenance of the unit, as outlined in the owner's manual. As outlined below, the warranty may be voided due to problems caused by lack of maintenance. Annual maintenance records should be retained.

Repair/replacement parts purchased by the consumer from FPI after the original coverage has expired on the unit will carry a 90 day warranty, valid with a receipt only. Any item shown to be defective will be repaired or replaced at our discretion. No labor coverage is included with these parts.

#### **Exclusions:**

This Limited Lifetime Warranty does not extend to paint, rust or corrosion of any kind due to a lack of maintenance or improper venting, combustion air provision, corrosive chemicals (i.e. chlorine, salt, air, etc.), door or glass gasket.

Malfunction, damage or performance based issues as a result of environmental conditions, location, chemical damages, downdrafts, installation error, installation by an unqualified installer, incorrect chimney components (including but not limited to cap size or type), operator error, abuse, misuse, use of improper fuels, accidents, lack of regular maintenance and upkeep, acts of God, weather related problems from hurricanes, tornados, earthquakes, floods, lightning strikes/bolts or acts of terrorism or war, which result in malfunction of the appliance are not covered under the terms of this Limited Lifetime Warranty.

# WARRANTY

---

FPI has no obligation to enhance or modify any unit once manufactured (i.e. as products evolve, field modifications or upgrades will not be performed on existing appliances).

Any unit showing signs of neglect or misuse will not be covered under the terms of this warranty policy and may void this warranty. This includes units with rusted or corroded fireboxes which have not been reported as rusted or corroded within three (3) months of installation/purchase. Any alteration to the unit which causes sooting or carboning that results in damage to the exterior fascia or over firing that can cause component or firebox/heat exchanger failure will not be covered by this warranty.

Units which show evidence of being operated while damaged, or with problems known to the purchaser and causing further damages will void this warranty.

Units where the serial no. has been altered, deleted, removed or made illegible will void this warranty.

Minor movement, expansion and contraction of the steel is normal and is not covered under the terms of this warranty.

Freight damages for products or parts are not covered under the terms of the warranty.

Porcelain/Enamel: Absolute perfection is neither guaranteed nor commercially possible. Any chips must be reported and inspected by the authorised selling dealer within three (3) days of installation. Any damage of this type not reported after this time period will be subject to rejection and any related warranty will not apply.

Special Finishes: Expect some changes in color as the product "ages" with constant heating and cooling. The manufacturer warranty does not cover tarnishing, changing colors and/or marks (i.e. finger prints, etc.) after the purchase of the product. Damage from the use of abrasive cleaners is not covered by warranty.

Products made or provided by other manufacturers and used in conjunction with the FPI appliance without prior authorisation from FPI may void this warranty.

**INCORRECT INSTALLATION OR GAS PRESSURE SETTINGS ARE NOT COVERED BY WARRANTY. A SERVICE OR CALLOUT FEE WILL BE CHARGED IN THESE CIRCUMSTANCES.**

## Limitations of Liability:

### 1. Exclusion of implied terms

The customer may have the benefit of consumer guarantees under the Australian Consumer Law. To the maximum extent permitted by law, all terms, conditions or warranties that would be implied into this Warranty or in connection with the supply of any goods or services by the supplier under law or statute or custom or international conventions are excluded.

### 2. Limitation of liability

(a) To the maximum extent permitted by law and subject to clauses 1 and 3, the supplier's total liability arising out of or in connection with its performance or its obligations pursuant to this Warranty, or arising out of or in connection with the supply of specific goods or services (including pursuant to or for breach of this Warranty, under statute, in equity or for tort, including negligent acts or omissions) is limited as follows: (i) the supplier shall have no liability to the customer for any Consequential Loss; (ii) without limiting the effect of clause 2(a)(i), the supplier's total aggregate liability for Loss, however arising, shall not exceed the GST exclusive aggregate price paid by the customer to the supplier for the specific goods or services that gave rise to the Loss in question.

(b) The limitations and exclusions in this sub-clause do not apply to the extent that any Loss is directly attributable to: (i) the personal injury or death caused by the supplier's default, breach of this Warranty or negligence; or (ii) fraud by the supplier.

(c) Each party must take reasonable steps to mitigate any Loss it suffers or incurs.

### 3. Limitation of liability under Australian Consumer Law Guarantees

(a) To the extent that goods supplied by the supplier are not goods of a kind ordinarily acquired for personal, domestic or household use and the customer is deemed to be a consumer for the purposes of section 64A of the Australian Consumer Law, the customer agrees that the supplier's liability for a failure to comply with a consumer guarantee that the customer may have a benefit under the Australian Consumer Law (other than a guarantee under sections 51 (title), 52 (undisturbed possession) and 53 (undisclosed securities)), is limited to, at the option of the supplier, one or more of the following: (i) replacement of the goods or the supply of equivalent goods; (ii) the repair of the goods; (iii) the payment of the cost of replacing the goods or of acquiring equivalent goods; or (iv) equivalent goods; or (v) the payment of the cost of having the goods repaired.

(b) To the extent that services supplied by the supplier are services other than services of a kind ordinarily acquired for personal, domestic or household use or consumption, the supplier's liability for failure to comply with a consumer guarantee that the customer may have the benefit of is limited to, at the option of the supplier: (i) the supply of the services again; or (ii) the payment of the cost of having the services supplied again.

### 4. Subject to Change

This Limited Warranty is given at the time of sale and purchase of the relevant fireplace product. The terms of this Limited Warranty may be amended from time to time by FPI in accordance with changes to business practices, consumer laws or other legal requirements. The rights and protections granted under the Limited Warranty are those in force in relation to a fireplace product at the time and in the place of sale of that product, and only those terms will be applicable in respect of that product.

### 5. Severability

Any term of this Limited Warranty that is invalid or unenforceable in any jurisdiction is to be read down for the purposes of that jurisdiction, if possible, so as to be valid and enforceable, and is otherwise capable of being severed to the extent of the invalidity or unenforceability, without affecting the remaining provisions of this Limited Warranty or affecting the validity or enforceability of that provision in any other jurisdiction.

### 6. Definitions

For purposes of clauses 1, 2 and 3:

(a) Consequential Loss means loss of expected savings, loss of use, loss of opportunity, loss of profit, loss of revenue, increased financing costs, loss arising from delay, or any consequential, special or indirect loss or damage, whether or not the possibility or potential extent of the loss or damage was known or foreseeable, and whether arising from a claim under indemnity, contract, tort (including negligence), statute or otherwise.

(b) Loss means any expense, cost or damage of any kind and includes Consequential Loss and a fine or penalty imposed by a statutory or other authority.



# WARRANTY

---

## How to Obtain Warranty Service:

Customers should contact the authorised selling dealer to obtain warranty service. In the event the authorised selling dealer is unable to provide warranty service, please contact FPI by mail at the address listed below. Please include your name, address, purchase date, selling dealer, serial #, type of unit, a brief description of the problem, email and telephone contact information, and a copy of your original tax invoice. A representative will contact you to make arrangements for an inspection and/or warranty service. (See below for Western Australia and/or New Zealand)

Please note Fireplace Products Australia Pty Ltd does not provide installation services.

### Fireplace Products Australia Pty Ltd

1 – 3 Conquest Way  
Hallam, VIC  
Australia, 3803  
Phone: +61 3 9799 7277  
Fax: +61 3 9799 7822

To obtain warranty service in Western Australia and/or New Zealand, please contact one of our authorised distributors in those areas:

#### Western Australia:

**Air Group Australia**  
28-30 Division St.  
Welshpool, WA  
Australia, 6106  
Phone: (08) 9350 2200  
Fax: (08) 9353 4225

#### New Zealand:

**Aber Holdings Ltd**  
PO Box 10095  
Te Rapa, Hamilton  
New Zealand, 3241  
Freephone: 0800 161 161

## Product Registration and Customer Support:

Thank you for choosing a Regency Fireplace. Regency strives to be a world leader in the design, manufacture, and marketing of hearth products. To provide the best support for your product, we request that you complete a product registration form at <http://www.regency-fire.com.au/Customer-Care/Warranty-Registration.aspx> within ninety (90) days of purchase.



## Product Registration and Customer Support:

Thank you for choosing a Regency Fireplace. Regency strives to be a world leader in the design, manufacture, and marketing of hearth products. To provide the best support for your product, we request that you complete a product registration form found on our Web Site under Customer Care within ninety (90) days of purchase.

For purchases made in **CANADA or the UNITED STATES:**

<http://www.regency-fire.com/Customer-Care/Warranty-Registration.aspx>

For purchases made in **AUSTRALIA:**

<http://www.regency-fire.com.au/Customer-Care/Warranty-Registration.aspx>

You may also complete the warranty registration form below to register your Regency Fireplace Product and mail and/or fax it back to us, and we will register the warranty for you. It is important you provide us with all the information below in order for us to serve you better.

## Warranty Registration Form (or Register online immediately at the above Web Site):

<b>Warranty Details</b>	
Serial Number (required):	
Purchase Date (required) (mm/dd/yyyy):	
<b>Product Details</b>	
Product Model (required):	
<b>Dealer Details</b>	
Dealer Name (required):	
Dealer Address:	
Dealer Phone #:	
Installer:	
Date Installed (mm/dd/yyyy):	
<b>Your Contact Details (required)</b>	
Name:	
Address:	
Phone:	
Email:	

For purchases made in **CANADA:**

**FPI Fireplace Products International Ltd.**  
6988 Venture St.  
Delta, British Columbia  
Canada, V4G 1H4

Phone: 604-946-5155  
Fax: 604-946-4349

For purchases made in the **UNITED STATES:**

**Fireplace Products U.S., Inc.**  
PO Box 2189 PMB 125  
Blaine, WA  
United States, 98231

Phone: 604-946-5155  
Fax: 604-946-4349

For purchases made in **AUSTRALIA:**

**Fireplace Products Australia Pty Ltd**  
1- 3 Conquest Way  
Hallam, VIC  
Australia, 3803

Phone: +61 3 9799 7277  
Fax: +61 3 9799 7822

For fireplace care and tips and answers to most common questions please visit our Customer Care section on our Web Site. Please feel free to contact your selling dealer if you have any questions about your Regency product.









---

***Installer: Please complete the following information***

**Dealer Name & Address:** \_\_\_\_\_  
\_\_\_\_\_

**Installer:** \_\_\_\_\_

**Phone #:** \_\_\_\_\_

**Date Installed:** \_\_\_\_\_

**Serial No.:** \_\_\_\_\_