

**Regency® Gi29LU  
Gas Insert**

**Owners &  
Installation Manual**



[www.regency-fire.com](http://www.regency-fire.com)

MODELS: Gi29LU-NG

Natural Gas

Gi29LU-LP

Propane

**⚠ Warning**  
**Fire or explosion Hazard**  
failure to follow safety warnings exactly could result in serious injury, death, or property damage.

- Do not store or use gasoline or other flammable vapours and liquids in the vicinity of this or any other appliance.

**- WHAT TO DO IF YOU SMELL GAS**

- Do not try to light any appliance.
- Do not touch any electrical switch: do not use any phone in your building. Leave the building immediately.
- Immediately call your gas supplier from a neighbour's phone. Follow the gas supplier's instructions.
- If you cannot reach your gas supplier, call the fire department.

- Installation and service must be performed by a qualified installer, service agency or the gas supplier.



Certified to/Certifié pour : ANSI Z21.88-2019

**Installer:** Please complete the details on the back cover and leave this manual with the homeowner.  
**Homeowner:** Please keep these instructions for future reference.

TO THE NEW OWNER

Congratulations! You are the owner of a state-of-the-art gas insert by Regency.

The Regency gas insert series of handcrafted appliances is designed to provide you with all the warmth and charm of a fireplace at the flick of a switch. The Gi29LU is approved by Intertek for safety and efficiency. As it also bears Regency's mark, it promises economy, comfort, and security for many trouble-free years to come.

Please take a moment to acquaint yourself with the instructions in this manual, as well as the many features of your Regency fireplace.

# DANGER

**HOT GLASS WILL  
CAUSE BURNS**

**DO NOT TOUCH GLASS  
UNTIL COOLED**

**NEVER ALLOW CHILDREN  
TO TOUCH GLASS**

**HOT GLASS WILL  
CAUSE BURNS**

**DO NOT TOUCH GLASS  
UNTIL COOLED**

**NEVER ALLOW CHILDREN  
TO TOUCH GLASS**

A barrier designed to reduce the risk of burns from the hot viewing glass is provided with this appliance and must be installed for the protection of children and other at risk individuals.

## CAUTION:

**HOT WHILE IN OPERATION. DO NOT TOUCH.  
SEVERE BURNS MAY RESULT. KEEP CHILDREN, CLOTHING, FURNITURE,  
GASOLINE, AND ANY OTHER LIQUIDS WITH FLAMMABLE VAPOURS AWAY.**

**KEEP BURNER AND CONTROL COMPARTMENT CLEAN.  
SEE INSTALLATION AND OPERATING INSTRUCTIONS ACCOMPANYING  
APPLIANCE.**

920-408

**NATIONAL  
FIREPLACE  
INSTITUTE**

**CERTIFIED**

www.nficertified.org

We recommend that our products be installed and serviced by professionals who are certified in the U.S. by the National Fireplace Institute® (NFI) or in Canada by Wood Energy Technical Training (WETT).

**This product can be installed in an aftermarket, permanently located manufactured home (USA only), or mobile home where not prohibited by local codes.**

**This appliance is for use with the type of gas indicated on the rating plate only. This appliance is not convertible for use with other gases unless a certified kit is used.**

# table of contents

## Dimensions

Unit Dimensions .....	4
Faceplate Dimensions .....	5

## Owner's Information

Copy of Safety Label.....	6
On/Off Switch .....	6
Know Your Appliance .....	9
Important Message .....	10
Important Information.....	10
Before You Start.....	10
For Your Safety .....	10
Specifications.....	10
Copy of Lighting Plate Instructions .....	11

## Installer's Information

Gas Installation Checklist.....	7
Gas Pressure Testing .....	12
Installation Into a Solid Fuel Burning Fireplace or Factory Built Fireplace.....	12
Factory-Built (Metal) Wood-Burning Fireplace Requirements .....	12
General Safety Information .....	12
Installation Checklist.....	13
Materials Required.....	13
Minimum Fireplace Dimensions.....	13
Electrical Receptacle in a Masonry Fireplace .....	13

## Installation

Minimum Fireplace Opening Sizes with Varying Faceplate/Backing Plate Options .....	14
Minimum Clearances to Combustibles .....	15
Mantel Clearances Without Mantel Deflector & Mantel Clearances with 2-1/2" Mantel Deflector .....	16
Using Steel Studs & Concrete Board Over Masonry Brick Fireplace ..	17
Leveling Legs Adjustment .....	18
Gas Connection .....	19
Vertical Venting .....	19
Alternate Approved Vertical Termination Caps/Adaptor .....	20
Restrictor Adjustment .....	21
Vertical Venting/Restrictor Settings for NG and LP.....	22
Vertical Venting/Restrictor Settings for FPI Co-Linear DV Vertical Termination Cap & Flashing (946-529) Enclosed .....	23
Vertical Venting/Clearance Requirements for FPI Co-Linear DV Vertical Termination Cap & Flashing (946-529) Enclosed .....	24
Horizontal Co-Linear Vent Kit (Masonry Fireplaces Only).....	25
Flue Collar Installation/Removal .....	26
Air Shutter Adjustment .....	27
NG System Data.....	28
LP System Data.....	28
High Elevation.....	28
Gas Line Installation .....	28
Pilot Adjustment.....	28
Gas Pipe Pressure Testing .....	28
820 Valve Description .....	28
Gas Shut Off Procedure .....	29
Conversion from Natural Gas to Propane .....	30
Derating Kit .....	32
Panel Installation .....	33
Birch & Oak Log Set Installation (Part #311-931 & 311-934) .....	36
Driftwood Log Set Installation (Part #311-930/P) .....	44
Screen Removal .....	51
Glass Door Removal .....	52
Faceplate/Finishing Trim Installation .....	53
Backing Plate Installation.....	54
Mantel Deflector Installation.....	56
Premium Faceplate Surround Installation .....	57
Traditional Faceplate Surround Install (Part #311-927, 311-928).....	58

Hearth Trim Installation - Trimming to Height.....	59
Hearth Trim Installation - Mounting Hearth Trim .....	60
Optional Wall Thermostat .....	61
Thermostat Wire Table.....	61
Supplied Remote Control .....	61
Final Check .....	61
Wiring Diagram .....	62

## Operation

Operating Instructions .....	63
Lighting Procedure .....	63
Shutdown Procedure .....	63
First Fire.....	63
Automatic Convection Fan Operation .....	63
On/Off Switch .....	63
On/Off/Pilot Extension Knob - Hi/Low Extension Knob Fan Control Knob .....	63
Proflame I Remote Control Operating Instructions .....	64
Proflame I Remote Receiver Battery Replacement.....	67
Operating Procedure for Remote Control .....	68
Normal Operating Sounds of Gas Appliances .....	69

## Maintenance

Maintenance Instructions .....	69
Door Glass .....	70
Glass Replacement .....	70
General Vent Maintenance .....	70
Log Replacement .....	70
Glass Gasket .....	70
Sparker Battery Change.....	70
Fan Replacement.....	71
Valve Replacement .....	72
Gas Maintenance - Recommended Annual Routine.....	74

## Parts

Parts - Main Assembly .....	75
Faceplates/Accessories .....	77

**Warranty .....78**

**Recycling .....84**

# dimensions

## Unit Dimensions

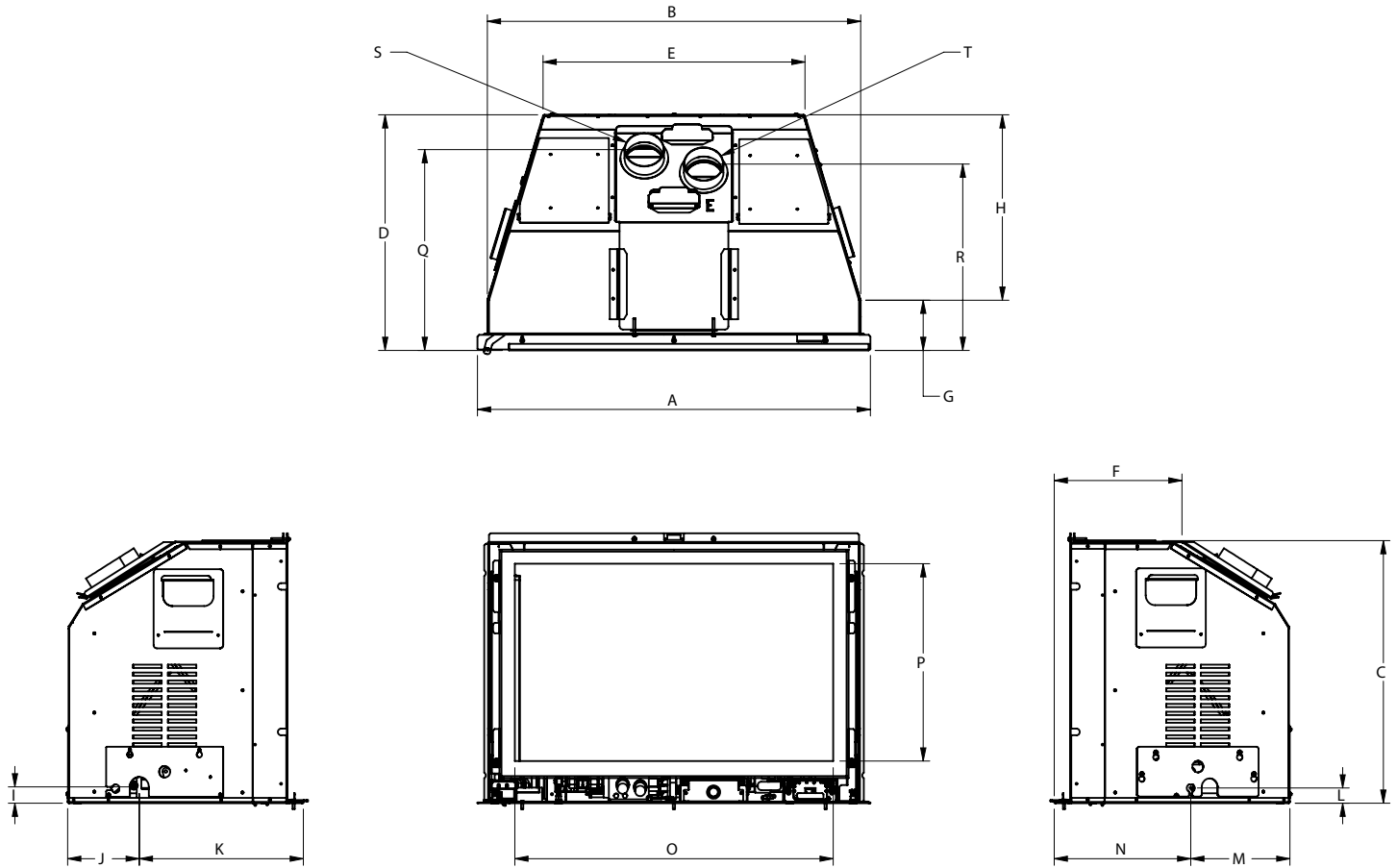

Letter	Description	Dimensions (inches)	Dimensions (mm)
A	Width	29-3/4"	756 mm
B	Outerbox Width	28-5/16"	719 mm
C	Outerbox Height	20-1/4"	514 mm
D	Outerbox Depth	17-7/8"	454 mm
E	Outerbox Rear Width	20"	508 mm
F	Front to Top Taper	8-3/8"	213 mm
G	Front to Side Taper	3-13/16"	97 mm
H	Rear to Side Taper	14-1/16"	357 mm
I	Gas Inlet Height	1-1/4"	32 mm
J	Gas Inlet Front Depth	5-1/2"	140 mm

Letter	Description	Dimensions (inches)	Dimensions (mm)
K	Gas Inlet Front Depth	12-7/16"	316 mm
L	Electrical Access Height	1-1/8"	29 mm
M	Electrical Access Rear Depth	7-1/2"	191 mm
N	Electrical Access Front Depth	10-3/8"	264 mm
O	Glass Viewing Area Width	24-1/8"	613 mm
P	Glass Viewing Area Height	15"	381 mm
Q	Front to Intake	15-1/16"	383 mm
R	Front to Exhaust	14"	356 mm
S	Intake Diameter	3"	76 mm
T	Exhaust Diameter	3"	76 mm

## Faceplate Dimensions

### Three-Sided Faceplate

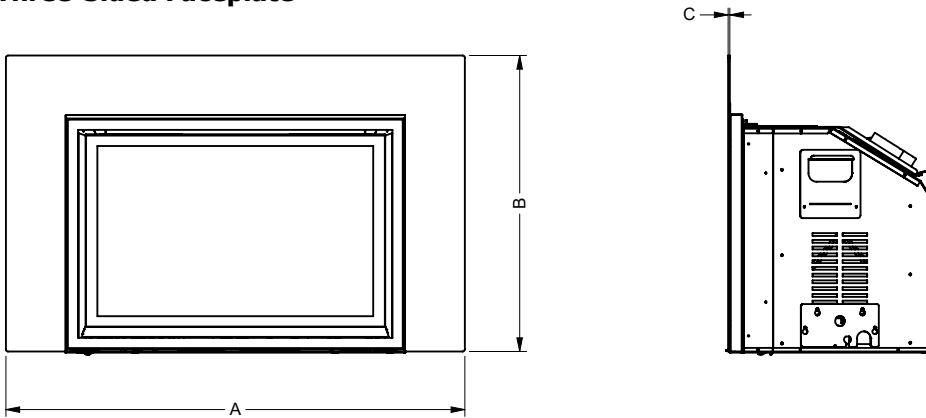

### Four-Sided Faceplate

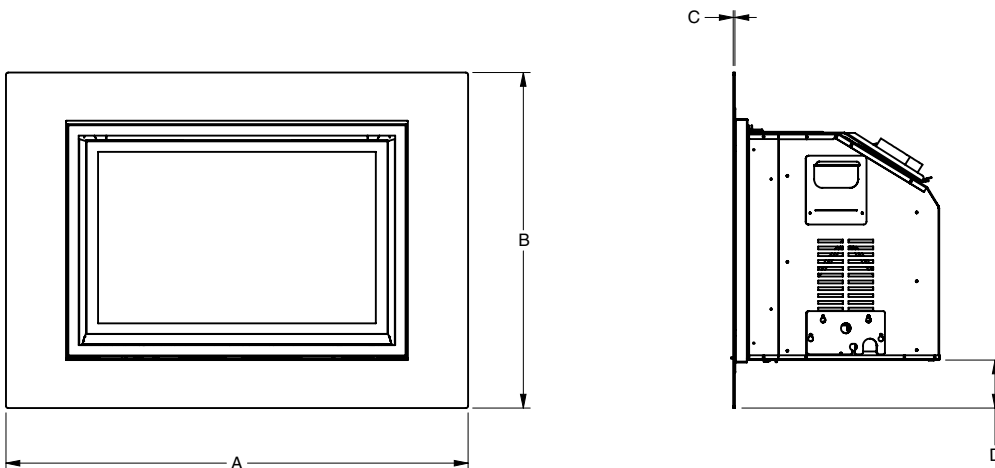



Faceplate	Dimensions			
	Width (A)	Height (B)	Depth (C)	Bottom Height (D)
Regular Faceplate	40-3/16" (1021 mm)	26" (660 mm)	1-1/4" (32 mm)	-
Regular Faceplate w/ Premium Surround	40-13/16" (1021 mm)	26-3/8" (670 mm)	1-11/16" (43 mm)	-
Flush Faceplate	40-3/16" (1021 mm)	26" (660 mm)	1/8" (3 mm)	-
Flush Faceplate w/Traditional Surround	45-3/4" (1162 mm)	28-3/4" (730 mm)	2-1/4" (57 mm)	-
4-Sided Flush Faceplate	40-3/16" (1021 mm)	29-1/4" (743 mm)	1/8" (3 mm)	4-3/16" (106 mm)
Finishing Trim	31-7/8" (810 mm)	21-7/8" (556 mm)	1/16" (2 mm)	-
4-Sided Finishing Trim	31-7/8" (810 mm)	23-1/8" (587 mm)	1/16" (2 mm)	1-1/8" (29 mm)
Oversized Backing Plate	47-1/2" (1207 mm)	31-1/2" (800 mm)	1/8" (3 mm)	-
3-Sided Custom Backing Plate	33-7/8" - 56-7/8" (860 mm - 1445 mm)	22-7/8" - 44-7/8" (581 mm - 1118 mm)	1/8" (3 mm)	-
4-Sided Custom Backing Plate	33-7/8" - 69" (860 mm - 1753 mm)	25-1/8" - 45" (638 mm - 1143 mm)	1/8" (3 mm)	2-1/8" minimum (54 mm min.)

# owner's information

## Copy of Safety Label

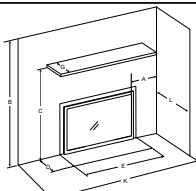
A copy of the label that accompanies each Gi29LU gas insert is below.

Gi29LU Serial Label		Duplicate Serial Number		565																																																																		
		<b>Listed: VENTED GAS FIREPLACE HEATER</b> <b>Certified to:</b> ANSI Z21.88-2019 Refer to Intertek's Directory of Building Products for detailed information.		<b>DO NOT REMOVE THIS LABEL</b> 565 Serial No.																																																																		
Model: Gi29LU-NG	<b>NATURAL GAS FIREPLACE INSERT: MODEL Gi29LU-NG</b> <b>Factory Equipped For Altitude 0-4500ft. (0-1370m)</b>																																																																					
	<table border="0"> <tr> <td>Min. Supply Pressure</td> <td>5"</td> <td>WC</td> <td>(1.25 kPa)</td> <td colspan="2"></td> </tr> <tr> <td>Low Setting Man. Pressure</td> <td>1.1"</td> <td>WC</td> <td>(0.27 kPa)</td> <td colspan="2"></td> </tr> <tr> <td>Max. Manifold pressure</td> <td>3.8"</td> <td>WC</td> <td>(0.95 kPa)</td> <td colspan="2"></td> </tr> <tr> <td colspan="6">Factory Equipped for Altitude 0-2,000ft (0-610m)</td> </tr> <tr> <td>Orifice</td> <td>#36</td> <td>DMS</td> <td colspan="3"></td> </tr> <tr> <td>Minimum input</td> <td>17,000</td> <td>Btu/h</td> <td>(4.98 kW)</td> <td colspan="2"></td> </tr> <tr> <td>Maximum input</td> <td>31,500</td> <td>Btu/h</td> <td>(9.22 kW)</td> <td colspan="2"></td> </tr> <tr> <td colspan="6">Field Convertible for Altitude 2,000 - 4,500ft (610m-1370m) - Use Conversion Kit #311-980</td> </tr> <tr> <td>Orifice</td> <td>#39</td> <td>DMS</td> <td colspan="3"></td> </tr> <tr> <td>Minimum Input</td> <td>16,500</td> <td>Btu/h</td> <td>(4.83 kW)</td> <td colspan="2"></td> </tr> <tr> <td>Maximum Input</td> <td>30,500</td> <td>Btu/h</td> <td>(8.93 kW)</td> <td colspan="2"></td> </tr> </table>					Min. Supply Pressure	5"	WC	(1.25 kPa)			Low Setting Man. Pressure	1.1"	WC	(0.27 kPa)			Max. Manifold pressure	3.8"	WC	(0.95 kPa)			Factory Equipped for Altitude 0-2,000ft (0-610m)						Orifice	#36	DMS				Minimum input	17,000	Btu/h	(4.98 kW)			Maximum input	31,500	Btu/h	(9.22 kW)			Field Convertible for Altitude 2,000 - 4,500ft (610m-1370m) - Use Conversion Kit #311-980						Orifice	#39	DMS				Minimum Input	16,500	Btu/h	(4.83 kW)			Maximum Input	30,500	Btu/h	(8.93 kW)	
Min. Supply Pressure	5"	WC	(1.25 kPa)																																																																			
Low Setting Man. Pressure	1.1"	WC	(0.27 kPa)																																																																			
Max. Manifold pressure	3.8"	WC	(0.95 kPa)																																																																			
Factory Equipped for Altitude 0-2,000ft (0-610m)																																																																						
Orifice	#36	DMS																																																																				
Minimum input	17,000	Btu/h	(4.98 kW)																																																																			
Maximum input	31,500	Btu/h	(9.22 kW)																																																																			
Field Convertible for Altitude 2,000 - 4,500ft (610m-1370m) - Use Conversion Kit #311-980																																																																						
Orifice	#39	DMS																																																																				
Minimum Input	16,500	Btu/h	(4.83 kW)																																																																			
Maximum Input	30,500	Btu/h	(8.93 kW)																																																																			
Model: Gi29LU-LP	<b>PROPANE GAS FIREPLACE INSERT: MODEL Gi29LU-LP</b> <b>Factory Equipped For Altitude 0-4500ft. (0-1370m)</b>																																																																					
	<table border="0"> <tr> <td>Min. Supply Pressure</td> <td>11"</td> <td>WC</td> <td>(2.74 kPa)</td> <td colspan="2"></td> </tr> <tr> <td>Low Setting Man. Pressure</td> <td>2.9"</td> <td>WC</td> <td>(0.72 kPa)</td> <td colspan="2"></td> </tr> <tr> <td>Max. Manifold Pressure</td> <td>10.5"</td> <td>WC</td> <td>(2.61 kPa)</td> <td colspan="2"></td> </tr> <tr> <td>Orifice</td> <td>#52</td> <td>DMS</td> <td colspan="3"></td> </tr> <tr> <td>Minimum Input</td> <td>17,000</td> <td>Btu/h</td> <td>(4.98 kW)</td> <td colspan="2"></td> </tr> <tr> <td>Maximum Input</td> <td>31,500</td> <td>Btu/h</td> <td>(9.22 kW)</td> <td colspan="2"></td> </tr> </table>					Min. Supply Pressure	11"	WC	(2.74 kPa)			Low Setting Man. Pressure	2.9"	WC	(0.72 kPa)			Max. Manifold Pressure	10.5"	WC	(2.61 kPa)			Orifice	#52	DMS				Minimum Input	17,000	Btu/h	(4.98 kW)			Maximum Input	31,500	Btu/h	(9.22 kW)																															
Min. Supply Pressure	11"	WC	(2.74 kPa)																																																																			
Low Setting Man. Pressure	2.9"	WC	(0.72 kPa)																																																																			
Max. Manifold Pressure	10.5"	WC	(2.61 kPa)																																																																			
Orifice	#52	DMS																																																																				
Minimum Input	17,000	Btu/h	(4.98 kW)																																																																			
Maximum Input	31,500	Btu/h	(9.22 kW)																																																																			
<b>Minimum Clearances to Combustibles from insert</b>				<b>Mantel Clearances</b>																																																																		
Side wall	A	8" (203 mm)		Min. Hearth Depth	D	12" (305 mm)																																																																
Ceiling	B	63.75" (1873 mm)		Min. Hearth Width	E	36" (914 mm)																																																																
Mantel	C	38.75" (984 mm)		Max. Mantel Depth	G	12" (305 mm)																																																																
Min. Alcove Width	K	54" (1372 mm)																																																																				
Max. Alcove Depth	L	36" (914 mm)																																																																				
<b>FPI Fireplace Products International, Ltd</b> Delta BC, CANADA				MADE IN CANADA / FABRIQUÉ AU CANADA																																																																		
This appliance must be installed in accordance with local codes, if any; if none, follow the National Fuel Gas Code, ANSI Z223.1. This appliance is only for use with the type of gas indicated on the rating plate. This appliance is not convertible for use with other gases unless a certified kit is used. This appliance is only for use with the type of gas indicated on the rating plate and may be installed in an aftermarket, permanently located, manufactured (mobile) home where not prohibited by local codes. See owner's manual for details. <b>WARNING:</b> This fireplace has been converted for use with a gas fireplace insert only and cannot be used for burning wood or solid fuels unless all original parts have been replaced, and the fireplace re-approved by the authority having jurisdiction. <b>This vented gas fireplace heater is not for use with air filters.</b> For use with glass doors certified with the appliance only. For use only with barrier (Part #311-417/P). Follow installation instructions.																																																																						
Electrical supply 115VAC, Less than 1A, 60Hz, Fan Part # 911-071/P CATEGORY 1 <b>VENTED GAS FIREPLACE HEATER - NOT FOR USE WITH SOLID FUELS.</b>																																																																						
920-428c																																																																						

**NOTE** Regency units are constantly improving. Check the safety label on the unit and if it is different from the copy provided here, the label on the unit is correct.

For the State of Massachusetts, installation and repair must be done by a plumber or gas fitter licensed in the Commonwealth of Massachusetts.

For the State of Massachusetts, flexible connectors shall not exceed 36 inches in length.

For the State of Massachusetts, the appliance's individual manual shutoff must be a t-handle type valve.

The State of Massachusetts requires the installation of a carbon monoxide alarm in accordance with NFPA 720 and a CO alarm with battery backup in the same room where the gas appliance is installed.

## On/Off Switch

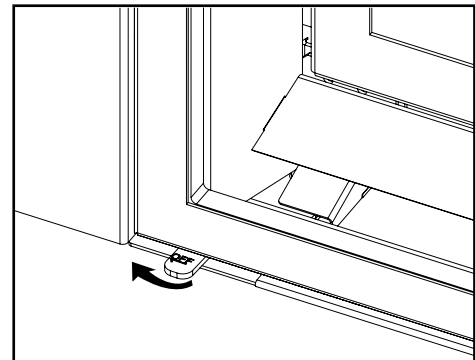

With the pilot on, turn the switch to the right to turn the burner on. Moving the switch to the left will turn the burner off.

**NOTE** This ON/OFF switch will be located on the lower left-hand side of the appliance as shown above.

To find the safety label, remove faceplate from the front of your unit (see manual); the safety label is located below the glass (see picture).

DO NOT REMOVE THE LABEL FROM THE UNIT.

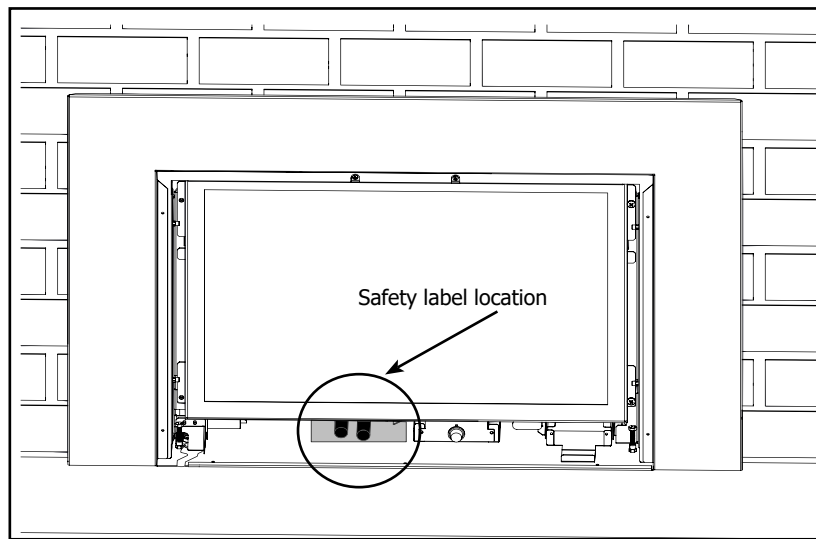

## Gas Installation Checklist

This general checklist does not contain all pertinent installation details or specifics and does not supersede the guidelines in this manual. Your Regency dealer/installer should use it in conjunction with manual instructions. Please follow all local codes and jurisdictions in authority.

<b>Customer:</b> _____	<b>Date Installed:</b> _____	
<b>Install Address:</b> _____	<b>Location of Fireplace:</b> _____	
<b>Serial No:</b> _____	<b>Installer:</b> _____	
<b>Model No:</b> _____		
<b>Site Requirements</b>	<b>YES</b>	<b>NO</b>
If applicable, are the insulation, vapour barrier, and drywall present if installed on an outside wall or chase?		
Does the area have a solid continuous base to support the unit?		
Will the area accommodate the size of the appliance and all clearances?		
Are the gas and electrical roughed into the area where the unit is being installed?		
In City & Grandview series cool wall applications, is the chase enclosure sealed to prevent heat from escaping? All hot air from the unit must exit via the mandatory ventilation openings.		
In City & Grandview applications, Is the chase enclosure vented with the mandatory heat ventilation openings? See manual for details.		
If applicable, is the masonry/factory built fireplace in its original condition with no modifications?		
If applicable, have the hearth requirements been met?		
<b>Unit Setup</b>	<b>YES</b>	<b>NO</b>
If applicable, are the standoffs and top nailing flange extensions installed and at the correct depth to accommodate finishing material? See manual for details.		
If applicable, is the fireplace level and secured, meeting framing clearances? See manual for details.		
If applicable, is the unit converted to top or rear vent per manual instructions, and the insulation discarded?		
<b>Venting</b>	<b>YES</b>	<b>NO</b>
Are the venting components approved for the unit installed?		
Does the venting configuration comply with venting diagrams?		
Is venting installed and secured, and are clearances for the vent pipe and termination cap maintained?		
If applicable, was a 1/4" rise maintained for every foot of horizontal run?		
Was the termination installed and sealed?		
Is the direct vent termination at the highest point in the vent assembly?		
If applicable, are both chimney liners continuous from flue collars to termination?		
<b>Electrical and Wiring</b>	<b>YES</b>	<b>NO</b>
Is the appliance connected to the household's 110/120v per local codes? Check local codes for receptacle placement.		
Were the connections in the fireplace tested with a circuit tester?		
Is the appliance properly grounded?		
If applicable, is the supplied electrical/gang box affixed to the wall to facilitate the mounting of the receiver/battery box ?		
If applicable, is all electrical, Ethernet, HDMI, networking, optical, wire/cables, conduits, etc. run through the wood or steel stud work as wires/cables of any kind cannot be exposed directly above or over the fireplace?		
<b>Gas</b>	<b>YES</b>	<b>NO</b>
Does the supply pressure meet the requirements shown on the rating plate?		
Was a conversion performed?		
Was a leak check performed and manifold pressures verified?		

# installation

Is the shut-off valve installed and easily accessible to the customer?		
<b>Finishing</b>	<b>YES</b>	<b>NO</b>
If applicable, is only noncombustible material installed in the noncombustible areas?		
Do clearances meet installation and manual requirements?		
Do the mantels and/or projections comply with the installation manual?		
If applicable, was the solid fuel fireplace warning plate installed?		
Is the chase enclosure fully open the full width, height and depth above the fireplace as per the requirements noted in the framing section?		
<b>Appliance Media Setup</b>	<b>YES</b>	<b>NO</b>
Do commands from the remote or wall switch light the pilot and main burner?		
Are the burner media/log set, glass door, and screen installed per instructions in the manual?		
Was the air shutter on the proper setting after running the unit for 20 minutes?		
If applicable, were the surround and trims installed according to the manual?		
Was the operation of the fan, lights (if installed), and flame modulation checked?		
<b>Customer Tutorial and Presentation</b>	<b>YES</b>	<b>NO</b>
Is the customer confident operating the new gas appliance and aware of all the features on the remote?		
Confirm that the rating and lighting plates are attached to the appliance. Do not remove.		
Was the customer informed of the location of the rating and lighting plates?		
Was accessing unit controls in a power outage explained to the customer?		
Are the model and serial numbers and the date of installation of the unit written in the manual and on the checklist?		
Were the warranty and unit registration reviewed with the customer?		
<b>Comments:</b>		



**Know Your Appliance**

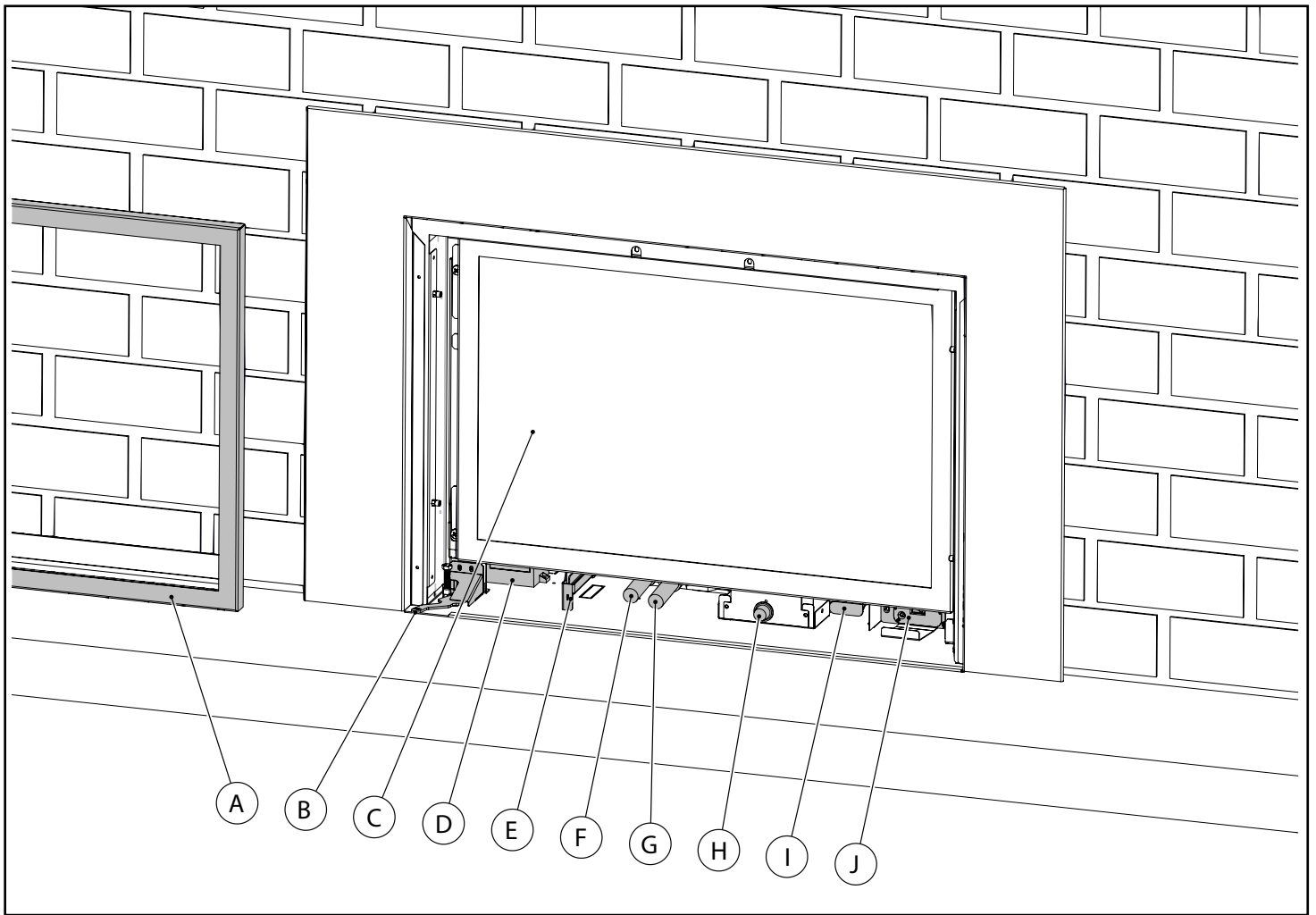

LETTER	DESCRIPTION	MORE INFO ON PAGE
A	SCREEN	49
B	ON/OFF SWITCH	60
C	GLASS DOOR	50
D	SPARKER BATTERY LOCATION	67
E	GAS SHUT-OFF VALVE	27
F	PILOT/ON/OFF CONTROL KNOB	60
G	FLAME ADJUSTMENT KNOB	60
H	FAN ADJUSTMENT KNOB	60
I	AIR SHUTTER ADJUSTMENT ARM	25
J	REMOTE BATTERY LOCATION	64

# owner's information

## Important Message

### SAVE THESE INSTRUCTIONS

The Gi29LU gas insert must be installed in accordance with the instructions in this manual; read them carefully before installing the unit. Consult the authority having jurisdiction to determine the need for permits prior to starting the installation. It is the responsibility of the installer to ensure this fireplace is installed in compliance with the manufacturer's instructions and all applicable codes.

## Important Information

Model Gi29LU standing pilot (approved for use in the USA only) is a millivolt system fitted with a pilot that stays lit 24/7, 365 days of the year. As long as the pilot is lit, it will remain on until it is turned off. This system is not approved for sale in Canada due to requirements associated with the seven-day timer.

## Before You Start

We are required by the Canadian Safety Standards and ANSI Standards to make you aware of the following.

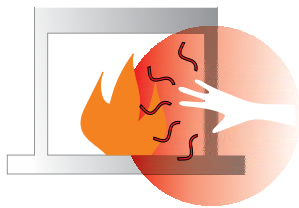

**INSTALLATION AND REPAIR SHOULD BE DONE BY AN AUTHORIZED SERVICE PERSON. THE APPLIANCE SHOULD BE INSPECTED BEFORE USE AND AT LEAST ANNUALLY BY A PROFESSIONAL SERVICE PERSON. MORE FREQUENT CLEANING MAY BE REQUIRED DUE TO LINT FROM CARPETING, BEDDING MATERIAL, ETC. IT IS IMPERATIVE THAT CONTROL COMPARTMENTS, BURNERS, AND CIRCULATING AIR PASSAGEWAYS OF THE APPLIANCE ARE KEPT CLEAN.**

**WARNING: Cancer and Reproductive Harm**  
[www.P65Warnings.ca.gov](http://www.P65Warnings.ca.gov)

919-874

**WARNING: FAILURE TO INSTALL THIS APPLIANCE CORRECTLY WILL VOID YOUR WARRANTY AND MAY CAUSE A SERIOUS HOUSE FIRE.**

**DUE TO HIGH TEMPERATURES, THE APPLIANCE SHOULD BE LOCATED OUT OF TRAFFIC AND AWAY FROM FURNITURE AND DRAPERIES.**

**CHILDREN AND ADULTS SHOULD BE ALERTED TO THE HAZARDS OF HIGH SURFACE TEMPERATURES, ESPECIALLY THE FIREPLACE GLASS, AND SHOULD STAY AWAY TO AVOID BURNS OR CLOTHING IGNITION.**

**A BARRIER DESIGNED TO REDUCE THE RISK OF BURNS FROM THE HOT VIEWING GLASS IS PROVIDED WITH THIS APPLIANCE AND SHALL BE INSTALLED FOR THE PROTECTION OF CHILDREN AND OTHER AT-RISK INDIVIDUALS**

**CLOTHING OR OTHER FLAMMABLE MATERIAL SHOULD NOT BE PLACED ON OR NEAR THE APPLIANCE.**

**IF THE BARRIER BECOMES DAMAGED, IT MUST BE REPLACED WITH THE MANUFACTURER'S BARRIER FOR THIS APPLIANCE.**

**ANY SAFETY SCREEN, GUARD, OR BARRIER REMOVED FOR SERVICING AN APPLIANCE MUST BE REPLACED PRIOR TO OPERATING THE APPLIANCE.**

## For Your Safety

This appliance requires air for proper combustion. Always provide adequate combustion and ventilation air. Follow instructions and information in CSA B149.1 (in Canada) or the National Fuel Gas Code ANSI Z223.1 (in the USA), regarding requirements for combustion and ventilation air.

## Specifications

At pressures over 1/2 psig, the pipe to the unit must be disconnected.

### Gas Max. Input Capacity:

Natural Gas	31,500 Btu/h (0-2000 ft./0-610 m)
	30,500 Btu/h (2,000-4,000 ft./610-1,370 m)
Propane	31,500 Btu/h

### Min. Input

Natural Gas	17,000 Btu/h (0-2,000 ft./0-610 m)
	16,500 Btu/h (2,000-4,000 ft./610-1,370 m)
Propane	17,000 Btu/h

**Fuels:** Approved for use with natural gas and propane. Approved at-is for use at 0' to 4,500' (0-1,370 m).

**Electrical:** 120 V A.C. system.

**Circulation Fan:** Variable speed, 140 CFM.

**Log Set:** Ceramic fibre, 10 per set

**Glass Crystals:** 2-1/2 pounds of crushed glass

**Vent System:** 3" (76 mm) co-linear aluminum flex (intake & exhaust). The unit's thermal efficiency rating is determined under continuous operating conditions, independent of any installed system.

## Copy of Lighting Plate Instructions

**FOR YOUR SAFETY READ BEFORE LIGHTING  
POUR VOTRE SÉCURITÉ – À LIRE AVANT LA MISE EN MARCHÉ**

**WARNING:** If you do not follow these instructions exactly, a fire or explosion may result causing property damage, personal injury or loss of life. Improper installation, adjustment, alteration, service or maintenance can cause injury or property damage. Refer to the owner's information manual provided with this appliance. For assistance or additional information consult a qualified installer, service agency or gas supplier.

**AVERTISSEMENT.** Quiconque ne respecte pas à la lettre les instructions dans la présente notice risque de déclencher un incendie ou une explosion entraînant des dommages, des blessures ou la mort.

Une installation, d'ajustement, de modification, de service ou d'entretien peut provoquer des blessures ou des dommages matériels. Reportez-vous au manuel du propriétaire fourni avec cet appareil. Pour obtenir de l'aide ou des informations supplémentaires consulter un installateur qualifié, une agence de service ou fournisseur de gaz.

- A) This appliance has a pilot that must be lighted by hand. When lighting the pilot, follow these instructions exactly.
- B) **BEFORE LIGHTING** smell all around the appliance area for gas. Be sure to smell next to the floor because some gas is heavier than air and will settle on the floor.
- WHAT TO DO IF YOU SMELL GAS**
- Do not try to light any appliance.
  - Do not touch any electric switch, do not use any phone in your building.
  - Leave the building immediately.
  - Immediately call your gas supplier from a neighbour's phone. Follow the gas supplier's instructions.
  - If you cannot reach your gas supplier, call the fire department.
- C) Use only your hand to push in or turn the gas control knob. Never use tools. If the knob will not push in or turn by hand, do not try to repair it; call a qualified service technician. Force or attempted repair may result in a fire or explosion.
- D) Do not use this appliance if any part has been under water. Immediately call a qualified service technician to inspect the appliance and replace any part of the control system and any gas control which has been underwater.
- A) Cet appareil est muni d'une veilleuse qui doit être allumée manuellement. Respectez les instructions ci-dessous à la lettre.
- AVANT LA MISE EN MARCHÉ,** reniflez tout autour de l'appareil pour détecter une odeur de gaz. Reniflez au niveau du plancher, car certains gaz sont plus lourds que l'air et peuvent s'accumuler au niveau du sol.

**QUE FAIRE SI VOUS SENTEZ UNE ODEUR DE GAZ :**

- Ne tentez pas d'allumer l'appareil
  - Ne touchez à aucun interrupteur; n'utilisez pas de téléphones se trouvant dans le bâtiment.
  - Sortez du bâtiment immédiatement
  - Appelez immédiatement votre fournisseur de gaz depuis un téléphone extérieur. Suivez les instructions du fournisseur.
  - Si vous ne pouvez pas rejoindre le fournisseur, appelez le service incendie.
- C) Ne poussez ni ne tournez la manette d'admission du gaz qu'à la main. Ne jamais employer d'outil à cette fin. Si la manette reste coincée, ne tentez pas de la réparer; appelez un technicien qualifié. Quiconque tente de forcer la manette ou de la réparer peut provoquer une explosion ou un incendie.
- D) N'utilisez pas cet appareil s'il a été plongé dans l'eau, même partiellement. Faites inspecter l'appareil par un technicien qualifié et remplacez tout élément du système de contrôle ou de commande qui a été plongé dans l'eau.

**CAUTION:** Hot while in operation. Do not touch. Severe burns may result. Due to high surface temperatures keep children, clothing and furniture, gasoline and other liquids having flammable vapors away. Keep burner and control compartment clean. See installation and operating instructions accompanying appliance.

**ATTENTION :** Surfaces chaudes lorsque l'appareil est en marche. Ne pas toucher. Risque de brûlures graves. En raison des températures élevées, les enfants, les vêtements et le mobilier, le carburant et tout autre liquide aux vapeurs inflammables doivent être tenus éloignés de l'appareil. Nettoyer régulièrement le brûleur et le compartiment des commandes. Voir les consignes d'installation et d'utilisation fournies avec l'appareil.

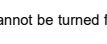

**LIGHTING INSTRUCTIONS / CONSIGNES D'ALLUMAGE**

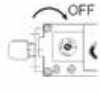
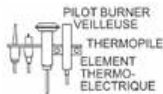
- 1) **STOP!** Read the safety information above on this label.
- 2) Push in gas control knob slightly and turn clockwise  to "OFF". Knob cannot be turned from "PILOT" to "OFF" unless knob is pushed in slightly. Do not force.

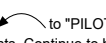
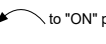

- 3) Wait five (5) minutes to clear out any gas. If you then smell gas STOP! Follow step "B" in the Safety Information above on this label. If you don't smell gas, go to the next step.
- 4) Push in gas control knob slightly and turn counterclockwise  to "PILOT" position.
- 5) Push in control knob all the way and hold in until the pilot lights. Continue to hold the control knob in for about 20 seconds after the pilot lights. Release the knob.
- 6) Push in gas control knob slightly and turn counterclockwise  to "ON" position
- 7) Turn on the flame switch.

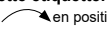
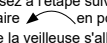

- 1) **STOP ! Lire les instructions de sécurité sur la portion supérieure de cette étiquette.**
- 2) Enfoncer légèrement le bouton de commande de gaz et tournez dans le sens horaire  en position OFF. Le bouton ne peut pas être tourné du PILOT à OFF à moins que le bouton soit enfoncé légèrement. Ne forcez pas.
- 3) Attendre cinq (5) minutes pour laisser échapper tout le gaz. Si vous sentez une odeur de gaz, ARRÊTEZ! Passez à l'étape "B" des instructions de sécurité sur la portion supérieure de cette étiquette. S'il n'y a pas d'odeur de gaz, passez à l'étape suivante.
- 4) Enfoncer légèrement le bouton de commande de gaz et tournez dans le sens antihoraire  en position PILOT.
- 5) Poussez le bouton de commande de gaz à fond et le maintenir enfoncé jusqu'à ce que la veilleuse s'allume. Maintenir le bouton de commande de gaz enfoncé pendant environ 20 secondes après l'allumage de la veilleuse. Relâcher le bouton de commande de gaz.
- 6) Enfoncer légèrement le bouton de commande de gaz et tourner dans le sens antihoraire  en position 'ON'.
- 7) Actionner l'interrupteur de flamme.

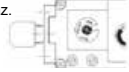
**TO TURN OFF GAS TO APPLIANCE / POUR COUPER LE GAZ AU NIVEAU DE L'APPAREIL**

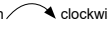
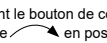
- 1) Turn off the flame switch.
- 2) Push in the gas control knob slightly and turn  clockwise to "OFF". Do not force.
- 3) Turn off all electric power to the appliance if service is to be performed.  
You may shut off the pilot during prolonged non use periods to conserve fuel.
- 1) Fermer l'interrupteur de flamme.
- 2) Enfoncer légèrement le bouton de commande de gaz et tournez dans le sens horaire  en position OFF. Ne pas forcer.
- 3) Avant d'effectuer des opérations d'entretien, couper l'alimentation électrique de l'appareil.  
Pour économiser le carburant, vous pouvez éteindre la veilleuse lorsque l'appareil reste longtemps inutilisé.

**DO NOT REMOVE THIS INSTRUCTION PLATE**

**NE PAS ENLEVER CETTE ÉTIQUETTE D'INSTRUCTIONS**

920-181a

# installer's information

## Gas Pressure Testing

During gas testing at pressures equal-to-or-less-than 1/2 psig. (3.45 kPa), the appliance's manual shut off valve must be closed to isolate it from the gas supply piping system.

## Installation Into a Solid Fuel Burning Fireplace or Factory Built Fireplace

The Gi29LU gas insert was tested and approved for venting into any masonry or approved solid fuel burning factory-built fireplace that the insert fits into. Refer to "Minimum Fireplace Dimensions" section for minimum fireplace clearances.

If the factory built fireplace\* height is too low for your Insert, you may remove the smoke baffle plate, damper, refractory (firebricks), glass doors, screen rails, screen mesh and log grates from the factory built fireplace. Save these items for reinstallation if the insert is removed. The fireplace flue damper can be fully blocked open or removed for installation of the gas fireplace insert.

Smoke shelves, shields, and baffles may be removed if attached by mechanical fasteners. Parts removed must not weaken the structural integrity of the factory-built fireplace.

The fireplace and chimney must be clean, in good working order, and constructed of non-combustible materials.

The surround panels should not seal ventilation openings on the fireplace.

Chimney cleanouts should fit properly.

**NOTE** Any alterations made to the listed solid fuel burning factory built fireplace may void the listing of the fireplace.

Cutting any sheet metal part of the fireplace in which the gas insert is to be installed is prohibited.

\*Check with a local inspector before installation.

Installers must mechanically attach the supplied label to the inside of the firebox of the fireplace into which the gas fireplace insert is installed.

**WARNING** This fireplace has been converted for use with a gas fireplace insert only. It cannot be used for burning wood or solid fuels unless all original parts are replaced and the fireplace re-approved by the authority having jurisdiction."

## Factory-Built (Metal) Wood-Burning Fireplace Requirements

**NOTE** Any parts that are removed must be removed in a way that would allow them to be reinstalled if the insert is ever removed (removal of rivets or screws is acceptable).

To reference parts—see illustration below.

**Must** be removed:

- 1 - Damper
- 2 - Grate (with log set)

May be removed (if applicable):

- 3 - Smoke shelf
- 4 - Internal baffles
- 5 - Screen
- 6 & 7 - Masonry lining or refractory
- 8 - Metal or glass doors

You must permanently mark the fireplace to indicate that it was altered and is no longer suitable for burning solid fuel (wood) unless the removed parts are reinstalled. Cutting any sheet metal parts is prohibited.

May be removed (in certain cases):

- 9 - Metal floor of the firebox
- 10 - The insulation and any structured rigid frame members must not be removed or altered (side and top of the door frame, side and top of the face of the fireplace, metal sides, etc.).

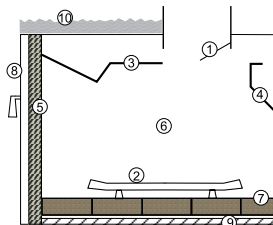

**CAUTION** Firebox floor removal is not covered under the appliance safety standard (ANSI Z21.88) used in the safety certification of this appliance. The Intertek safety certification does not apply to this method of installation. Before installing the appliance using this method, contact the Authority Having Jurisdiction to determine if this installation is acceptable in your area. The sheet metal base of the fireplace must be left in place and a minimum 1/2" cement board sheet placed under the entire length and width of the appliance.

If the factory-built fireplace has no gas access hole(s), one that is 1-1/2" (37-1/2 mm) or less may be drilled through the lower sides or bottom of the firebox. This access hole must be plugged with non-combustible insulation after the gas supply line is installed.

## General Safety Information

1. The appliance installation must conform with local codes, or in the absence of local codes, with CSA B149.1 (in Canada) or the National Fuel Gas Code ANSI Z223.1 in the USA. This appliance should be installed by a qualified gas fitter technician only.
2. Installation and repair should be done by a qualified service person.
3. The appliance should be inspected before use and at least annually by a professional service person. More frequent cleaning may be required due to lint from carpeting, bedding material, animal hair, etc. It is imperative that you keep control compartments, burners, and circulating air passageways of the appliance clean.
4. See general construction and assembly instructions. Install this appliance in a vented, non-combustible fireplace only.
5. This appliance is listed for bedroom installations when used with a listed Millivolt thermostat. Some areas may have further requirements; check local codes before installation.
6. Always vent this insert to the outside of the building envelope - never vent to another room or inside a building. Make sure that the vent is properly sized and of adequate height to provide the proper draft.
7. Inspect the venting system annually for blockages and any signs of deterioration.
8. Any glass removed for servicing must be replaced prior to operating the appliance.
9. To prevent injury, do not allow anyone unfamiliar with its operation to use the fireplace.
10. This appliance cannot be operated without brick or enamel panels.
11. Due to high temperatures, the appliance should be located out of high traffic areas and away from furniture and draperies. Children and adults should be alerted to the hazards of high surface temperatures, especially the fireplace glass and gold trims, and should stay away to avoid burns or clothing ignition. Young children should be carefully supervised while in the same room as the appliance. Clothing or other flammable material should not be placed on or near the appliance.

**WARNING** Failure to position the parts in accordance with the diagrams in this manual or failure to use only parts specifically approved with this appliance may result in property damage or personal injury.

## Installation Checklist

Before installing the vent system, ensure that the damper plate is open and secure to prevent it from falling and crushing the liner.

The Regency gas insert is installed as listed.

1. Check all clearances to combustibles. Refer to sections "Minimum Fireplace Dimensions" and "Minimum Clearances to Combustibles".
2. Make the gas connection. Refer to section "Gas Connection".
3. Install the two liners (3" intake and 3" exhaust) to the sliding connector plate. Refer to section "Flue Collar Installation/Removal".
4. Slide the unit halfway into the fireplace.
5. Pull the vent connector plate through the tapered brackets and fasten it to the front plate. Refer to section "Flue Collar Installation/Removal."
6. Slide the unit fully into the fireplace. Level if necessary.
7. Test gas pressure. Refer to section "Gas Pipe Pressure Testing". Check aeration system. Refer to section "Air Shutter Adjustment".
8. Install standard and optional features. Refer to the following sections:
  - a. Panel Installation
  - b. Log Set Installation
  - c. Faceplate Installation
  - d. Minimum Clearances to Combustibles
  - e. Minimum Fireplace Opening Sizes with Varying Faceplate/Backing Plate Options
  - f. Conversion from Natural Gas to Propane
9. Final check: Before leaving this unit with the customer, the installer must ensure that the appliance is firing correctly. This includes:
  - a) Clocking the appliance to ensure the correct firing rate.
  - b) Adjusting the primary air, if required, to ensure that the flame does not carbon. See "Gas Insert Aeration System" section.
  - c) Ensuring that the appliance is venting correctly.

## Materials Required

No electrical power supply is required for the gas control to operate. However, a AA battery is required for the DC sparker. A 120-Volt AC power cord is hooked up to the fan. Plug the three-wire cord into a suitable receptacle. Do not cut the ground terminal off under any circumstances. The appliance must be electrically grounded in accordance with local codes, the current version of CSA C22.1 (in Canada), or in the absence of local codes, with the National Electrical Code ANSI/NFPA 70-1987.

## Minimum Fireplace Dimensions

The minimum fireplace clearances & dimensions for the Regency gas insert are shown in the following diagram:

**NOTE** Also, see minimum fireplace opening sizes with varying faceplate, finishing trim, and backing plate options on the next page.

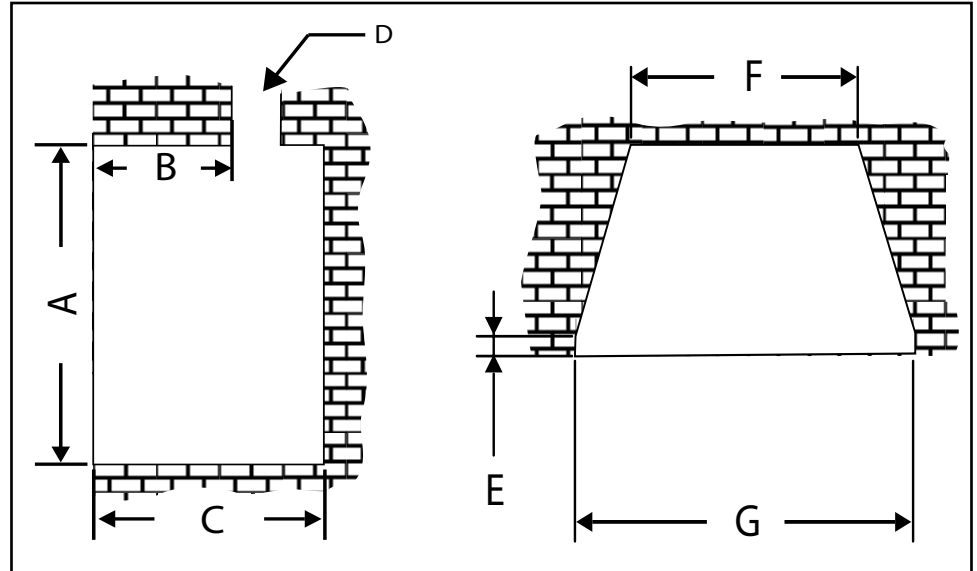

A Height	B Max. Lintel Bar Depth	C Depth	D Damper Opening	E Front Depth to Taper	F Width (rear)	G Width (front)
20-1/4" (514 mm)	11-3/8" (289 mm)	16-3/4" (425 mm)	8" x 4" min. (203 mm x 102 mm)	2-5/8" (67 mm)	20" (508 mm)	29" (737 mm)

## Electrical Receptacle in a Masonry Fireplace

The electrical receptacle can be placed on the left or right side of the unit within the masonry enclosure, respecting the following conditions:

1. Distance from the receptacle face to the gas insert: minimum 3" (76 mm)
2. Place the receptacle as far back as possible, so that it is near the back of the gas insert when installed.
3. Height from the top of the receptacle to the floor of the masonry fireplace: maximum 3.5" (89 mm)
4. The receptacle box and receptacle cover must be made of metal.
5. Where the 120-volt fan assembly power cord exits toward the receptacle, it must not come into contact with the back or sides of the gas insert. It can only touch the faceplate.

When installed, this appliance must be grounded in accordance with local codes, or in their absence, the National Electrical Code ANSI/NFPA 70, or the Canadian Electrical code CSA C22.1.

**IMPORTANT** Check with your local inspector before starting this installation, as some jurisdictions may not allow placement of this receptacle within a masonry chimney.

# installation

## Minimum Fireplace Opening Sizes with Varying Faceplate/Backing Plate Options

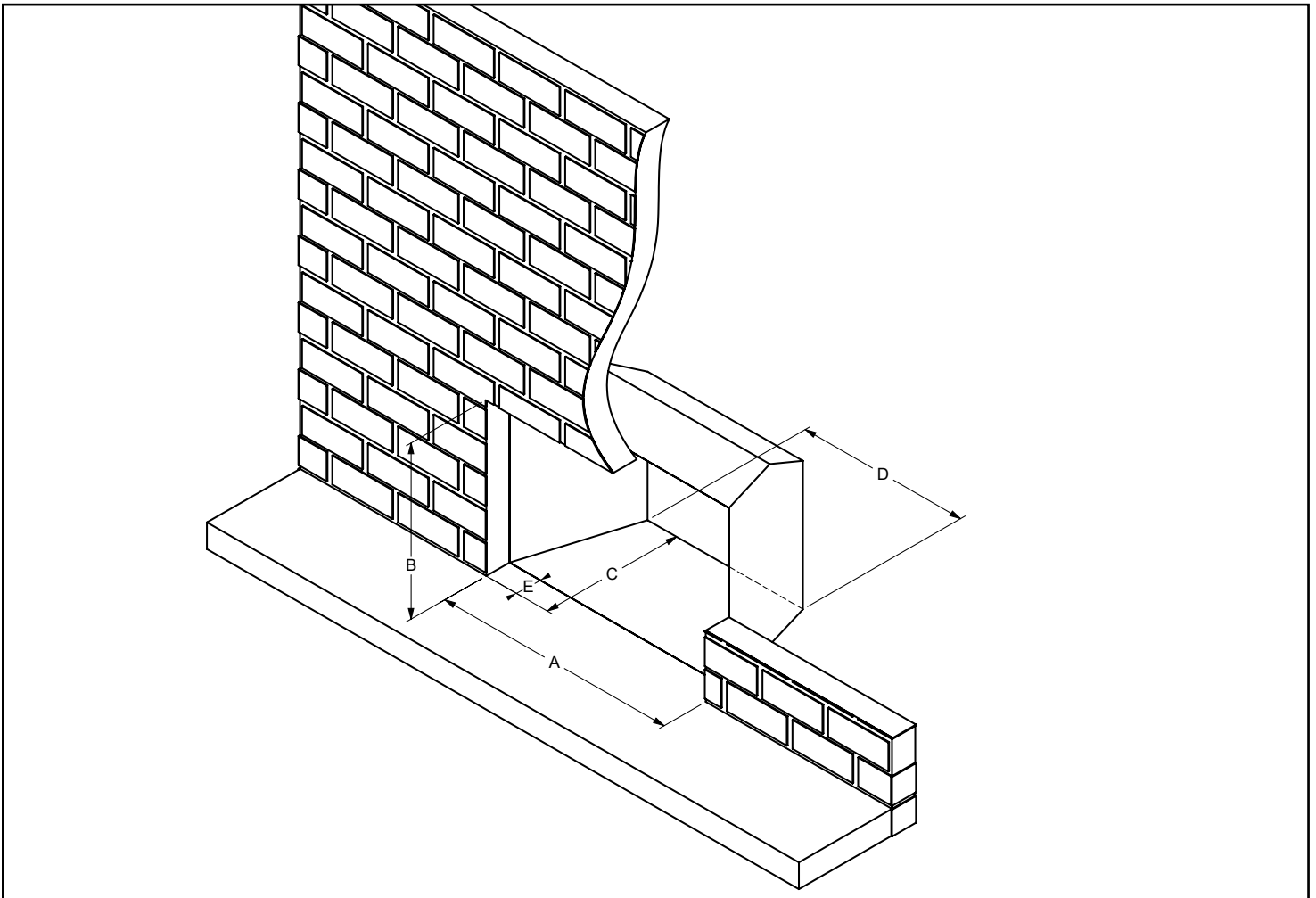

Faceplate	Dimensions				
	Minimum Install Width (A)	Minimum Install Height (B)	Minimum Install Depth (C)	Minimum Rear Width (D)	Taper Depth (E)
Regular Faceplate	28-7/16" (722 mm)	20-1/4" (514 mm)	16-11/16" (424 mm)	20" (508 mm)	2-13/16" (71 mm)
Regular Faceplate w/ Backing Plate	30-7/8" (784 mm)	21-7/16" (545 mm)	16-3/4" (425 mm)	20" (508 mm)	2-11/16" (68 mm)
Regular Faceplate w/ Premium Surround	28-7/16" (722 mm)	20-1/4" (514 mm)	16-5/8" (422 mm)	20" (508 mm)	2-5/8" (67 mm)
Regular Faceplate w/ Premium Surround and Backing Plate	30-7/8" (784 mm)	21-7/16" (545 mm)	16-1/2" (419 mm)	20" (508 mm)	2-1/2" (64 mm)
Flush Faceplate	30" (762 mm)	21-1/16" (535 mm)	17-15/16" (456 mm)	20" (508 mm)	3-7/8" (98 mm)
Flush Faceplate w/ Backing Plate	30-7/8" (784 mm)	21-7/16" (545 mm)	17-13/16" (452 mm)	20" (508 mm)	3-3/4" (95 mm)
Flush Faceplate w/ Traditional Surround	28-7/16" (722 mm)	20-1/4" (514 mm)	15-15/16" (405 mm)	20" (508 mm)	1-7/8" (48 mm)
Flush Faceplate w/ Traditional Surround and Backing Plate	30-7/8" (784 mm)	21-7/16" (545 mm)	15-13/16" (402 mm)	20" (508 mm)	1-3/4" (45 mm)
4-Sided Flush Faceplate	30" (762 mm)	21-5/16" (541 mm)	17-15/16" (456 mm)	20" (508 mm)	3-7/8" (98 mm)
Finishing Trim	30" (762 mm)	21-1/16" (535 mm)	18" (457 mm)	20" (508 mm)	3-15/16" (100 mm)
Finishing Trim w/ Backing Plate	30-7/8" (784 mm)	21-7/16" (545 mm)	17-7/8" (454 mm)	20" (508 mm)	3-7/8" (98 mm)
4-Sided Finishing Trim	30" (762 mm)	21-5/16" (541 mm)	18" (457 mm)	20" (508 mm)	3-15/16" (100 mm)

## Minimum Clearances to Combustibles

The clearances listed below are minimum distances unless otherwise stated.

A major cause of fires is failure to maintain required clearances (airspace) to combustible materials. It is of the greatest importance that this decorative gas appliance is installed only in accordance with these instructions.

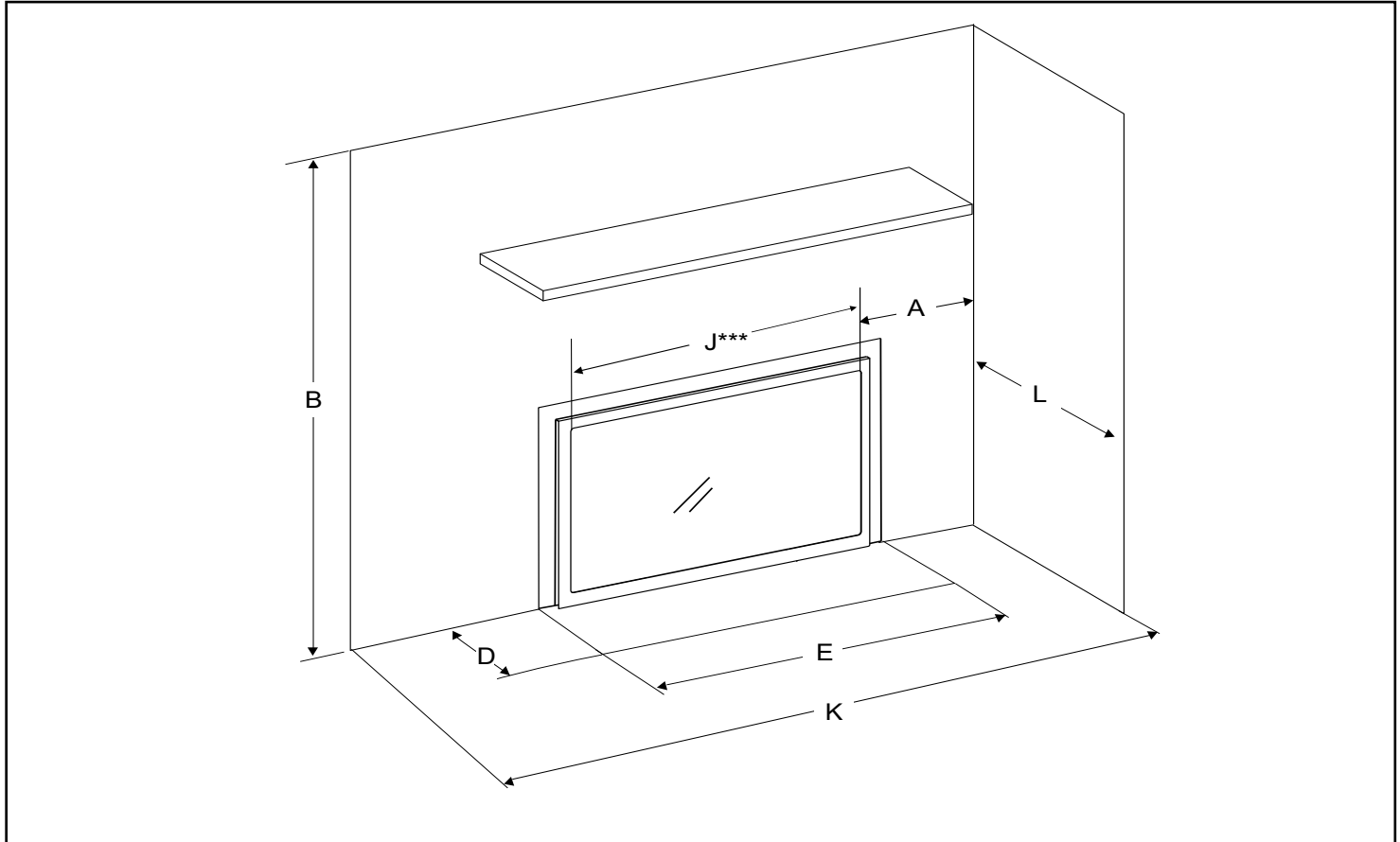

Diagram 1

Clearance	Dimension	Measured From:
A: Sidewall	8" / 203 mm	***From inside edge of faceplate / doors
B: Ceiling	63-3/4" / 1873 mm	From base of unit
D: Min. Hearth Depth	12" / 305 mm	Not required if unit raised 3" (76 mm) off the floor.
E: Min. Hearth Length	36" / 914 mm	Not required if unit raised 3" (76 mm) off the floor.
K: Min. Alcove Width	54" / 1372 mm	
L: Max. Alcove Depth	36" / 914 mm	From the front of the unit.
M: Mantel Deflector	2-1/2" / 89 mm*	

**NOTES**

- A 36" (914 mm) wide x 12" (305 mm) deep, non-combustible hearth is required in front of the appliance unless the unit is raised 3" (76 mm) off the floor.
- \*An optional 2-1/2" (64 mm) mantel deflector reduces the mantel height to 13" (330 mm) from the top of the unit @ 1" (25 mm) depth.
- (J): \*\*\*Measured from the inside edge of the faceplate/doors - reference only: 27-1/4" (692 mm)

# installation

## Mantel Clearances Without Mantel Deflector | Mantel Clearances with 2-1/2" Mantel Deflector

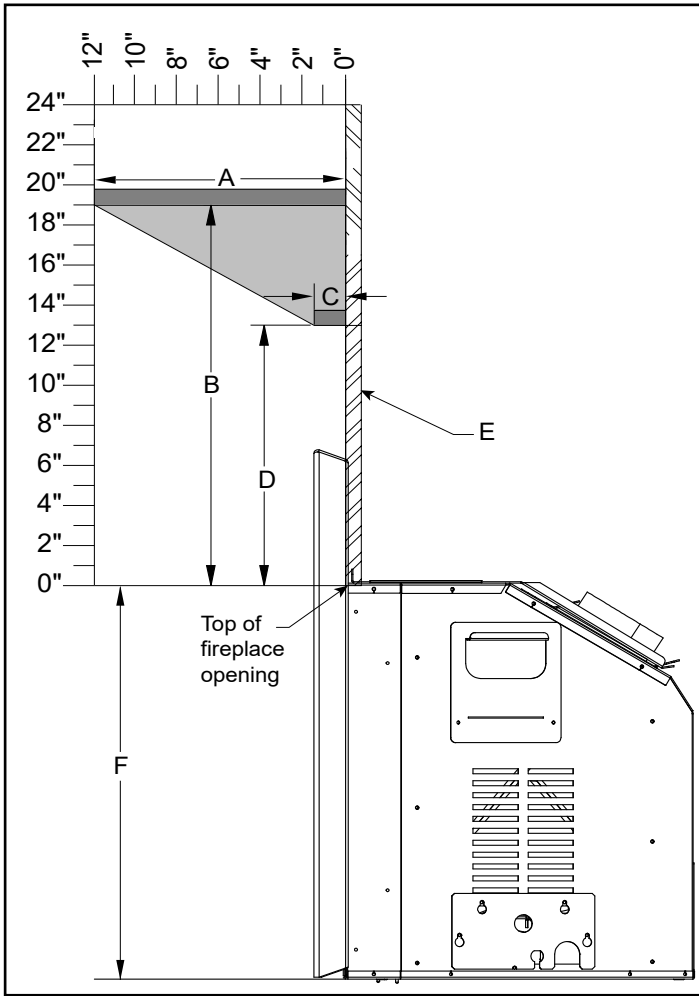

Diagram 2

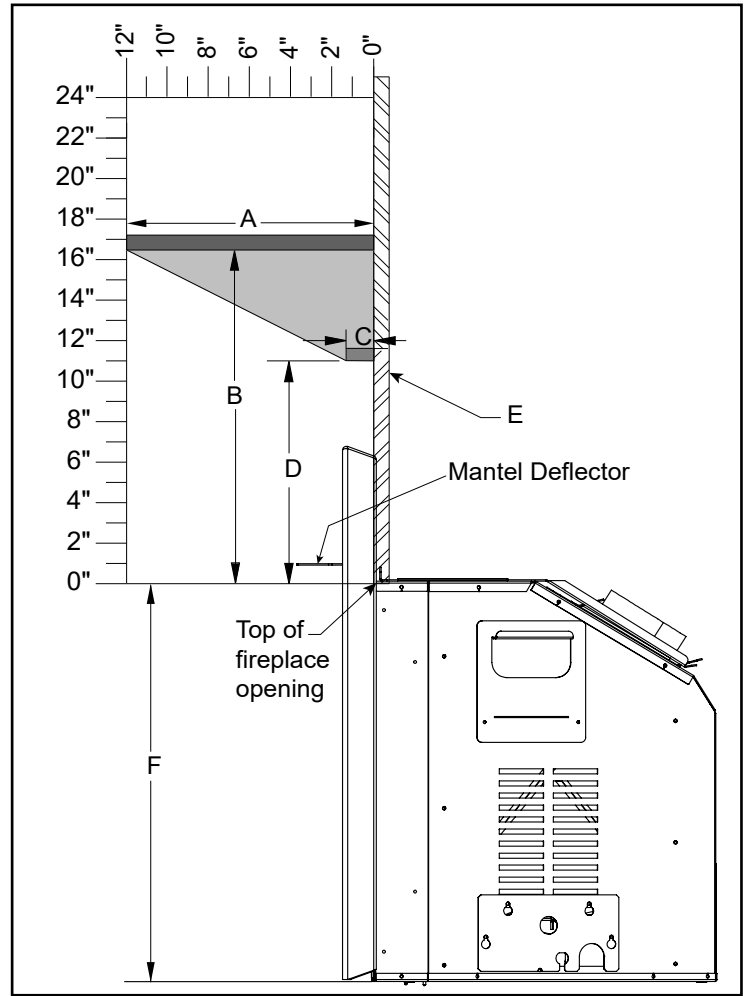

Diagram 3

A	12" (305 mm)
B	19" (483 mm)
C	1-1/2" (38 mm)

D	13" (330 mm)
E	Non Combustible Materials
F	19-3/4" (451 mm) to base of unit

A	12" (305 mm)
B	16-1/2" (419 mm)
C	1-1/2" (38 mm)

D	11" (279 mm)
E	Non Combustible Materials
F	19-3/4" (451 mm) to base of unit

### WARNING

Although this appliance passes safety certification, the hearth in front of the fireplace becomes very hot when the fireplace heats. Do not use the hearth as a seat or shelf.

### NOTES

- A 2-1/2" (64 mm) mantel deflector reduces mantel height to 11" (279 mm) from the top of the fireplace opening at 1-1/2" (38 mm) depth.
- A non-combustible mantel may be installed at a lower height if the framing is made of metal studs covered with a non-combustible board. The non-combustible mantel, when installed at a lower overall height, may not be lower than 6" (152 mm) from the top of the fireplace opening.
- All material used must be non-combustible.





## Using Steel Studs and Concrete Board Over Masonry Brick Fireplace

The masonry front brick facing can be removed and replaced with non-combustible materials such as steel studs and concrete board/dura rock/micor board as per diagram 1, only if safe to do so. Steel stud may also be placed in front of the masonry brick if left in place. This is the preferred method depending on the condition of the masonry brick fireplace.

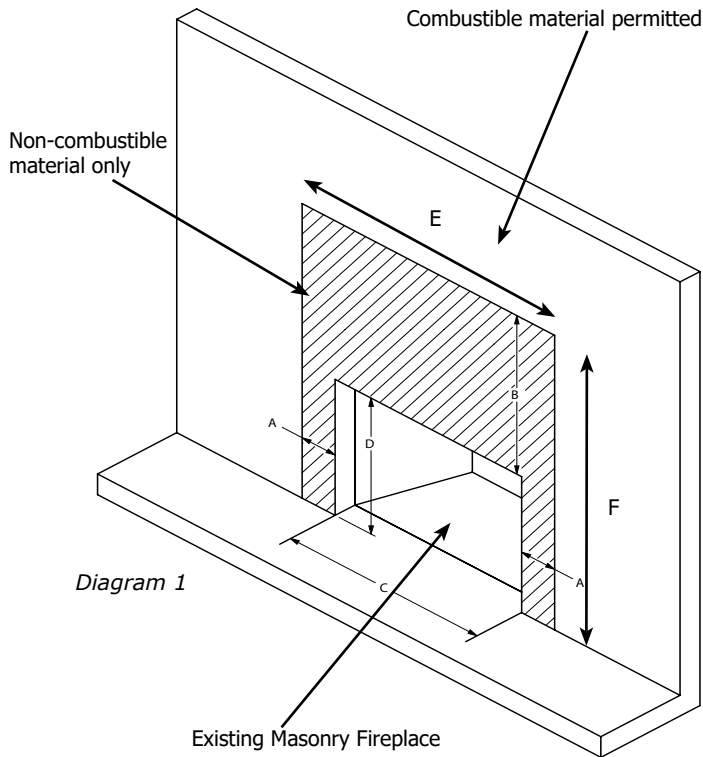
The opening between the front of the masonry firebox and non-combustible materials such as steel studs must be sealed so heat cannot run between the face of the masonry fireplace and the refacing materials. Only finishing materials such as tile, stone, brick, or similar materials that are non-combustible may be used. Use materials that are uniform so that when the unit is positioned, there are no visible gaps on the sides or top of the surround.



DIMENSIONS	
A - Horizontal clearance	8" (203 mm)
B - Vertical clearance	23" (584 mm)
C - Opening Width	30-1/4" min. (768 mm)
D - Opening Height	21-1/2" min. (546 mm)
E - Minimum Total Width	46-1/4" (1175 mm)
F - Minimum Total Height	41-3/4" (1060 mm)

- Combustible Facing Over Combustible Framing 
- Non-Combustible Facing Over Non-Combustible Framing 

# installation

## Leveling Legs Adjustment

**NOTE** • The leveling of the appliance must be done prior to hooking up gas line and vent system.

1. The leveling bolts can be installed with bolts from above or below (preferred method) to level the appliance. If choosing to go above, follow steps below. If choosing to go from below, see step 5. From the back of the unit, remove the six screws, then lift the fan mount plate out.

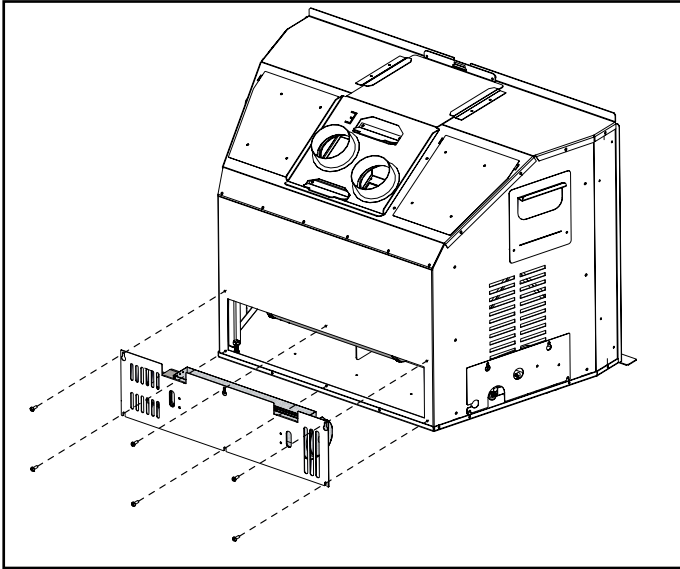

2. Screw the 2 2-1/2" (64 mm) bolts supplied inside manual package to the 2 nutserts located at the rear corners of appliance. Using a 7/16" wrench or socket, tighten or loosen the bolts as needed. The rear bolts can be adjusted up to 2-1/8".
3. Reinstall the fan mount plate.

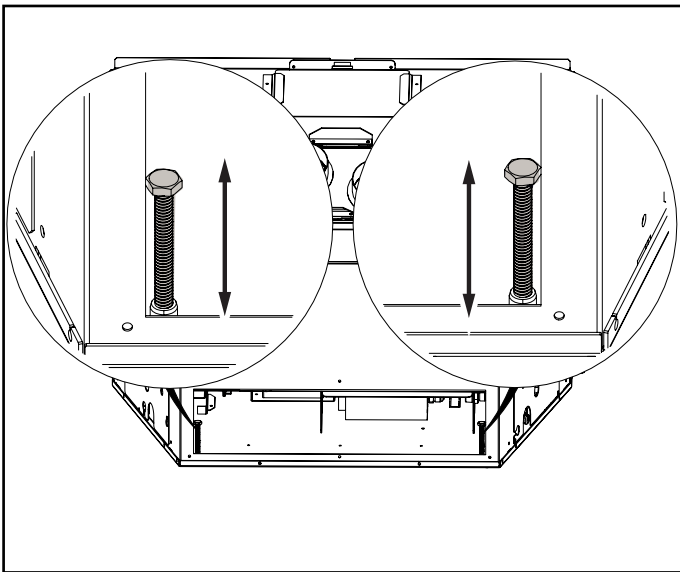

4. The front leveling bolts can be accessed from the front of the insert, on the bottom left and right sides. Once it is in position, adjust the bolts to ensure the appliance is level and won't rock.

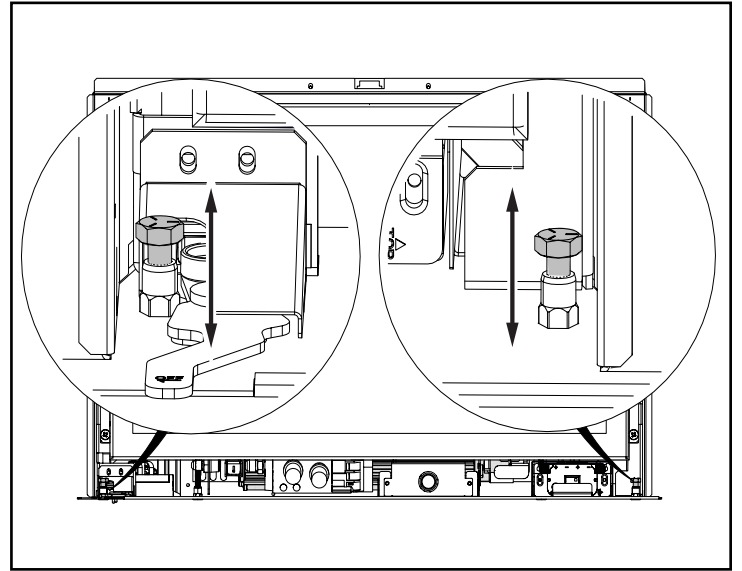

5. From below: The bolts can be flipped around and installed from the bottom of the insert for extended length. Once it is in position, adjust the bolts to ensure the appliance is level and won't rock.

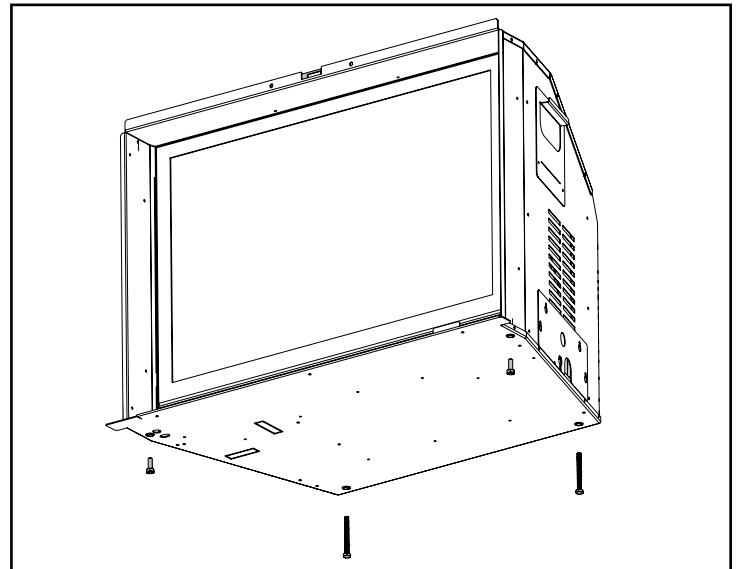

## Gas Connection

**WARNING** Only people licensed to work with gas piping may make the gas connections to this appliance.

1. If the appliance is installed into an existing chimney system, thoroughly clean the masonry or factory-built fireplace.
2. The appliance has an opening on the left side of the control compartment. A 3/8" NPT gas supply pipe must be brought near the opening.
3. Locate the centre point where the vent will pass through the chimney, above the appliance. Move the appliance to the installation location. Ensure that the insert is level.
4. Do not cut any sheet metal parts of the fireplace into which the gas insert will be installed.
5. If the factory-built fireplace has no gas access hole(s), drill one of 1-1/2" (37-1/2 mm) or less through the lower sides or bottom of the firebox. The access hole must be plugged with non-combustible insulation after the gas supply line is installed.

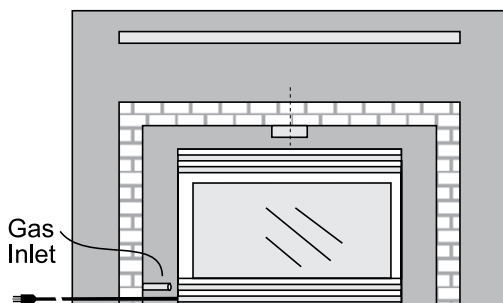

## Vertical Venting

**THE APPLIANCE MUST NOT BE CONNECTED TO A CHIMNEY FLUE SERVING A SEPARATE SOLID FUEL BURNING APPLIANCE.**

This appliance is designed to attach to two 3" (76 mm) co-linear aluminum flex running the full length of the chimney. The flue length must be a minimum of 8' (2.44 m) and a maximum of 35' (10.7 m) long. See the chart below for minimum distances from the roof. Periodically check that the vent is unrestricted.

Masonry chimneys may take various contours which the flexible liner will accommodate. However, **keep the flexible liner as straight as possible** (avoid unnecessary bending).

Attach both the exhaust and intake flue liners to both the termination cap & flue collar at the appliance with a minimum of three self-tapping screws. Use Mil-Pac sealant to seal the pipes.

The air intake pipe must be attached to the inlet air collar of the termination cap.

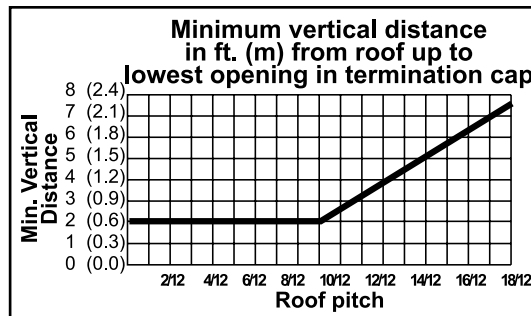

**IMPORTANT** This appliance was tested and certified as a complete system with the noted termination caps and flex liner. Only the listed termination caps/flex liner noted below can be used. Use of termination caps or flex liners not listed in this manual will void the warranty and certification of this appliance. It is also important not to enclose the termination cap inside a masonry chimney rain cap, or similar. The termination must be exposed on all four sides and above to exhaust and draw air into the firebox. There is an exception as the 946-529 Co-linear DV Vertical Termination Cap may be enclosed inside of a masonry chimney rain cap as long as it meets the requirement. See full details in this instruction manual.

Part #	Description
948-305	3" Flex - 35 ft.
946-529	Co-linear DV Vertical Termination Cap

**NOTES** When attaching the two 3 inch (51-76 mm) liners to the termination cap and prior to sliding them down the chimney, it is good practice to mark the liners "exhaust" & "air intake". This prevents mixing up the liners at the flue collar connection of the appliance. If facing the appliance from the front, the air intake is located on the left and the exhaust flue on the right.

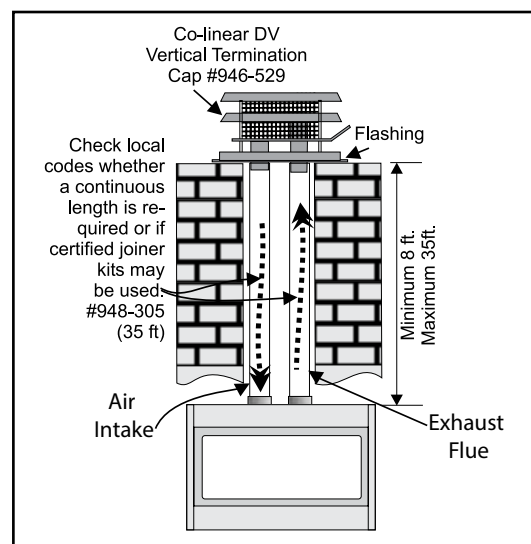

# installation

## Alternate Approved Vertical Termination Caps/Adaptor

### Alternate Approved Caps

Option 1

46DVA-CL33 - Vertical High Wind Cap With Flashing. Also includes 3" (76 mm) x 35' (10.7 m) Air Inlet Liner & 3" (76 mm) x 35' (10.7 m) Exhaust Liner

Option 2

46DVA-VC Vertical Termination Cap - Low profile

OR

46DVA-VCH Vertical High Wind Cap

AND

46DVA-GK 3" Co-linear Adaptor with flashing

**Note: Both Air Inlet/Exhaust Liners Would Need To Be Purchased Separately with Option 2 as they are not included.** With option 2, Simpson DuraVent pipe lengths can be added if required to meet clearance requirements. The air intake pipe must be attached to the inlet air collar of the termination cap.

In areas with consistently high winds, we recommend using the Simpson Dura-Vent System (46DVA-GK adaptor and 46DVA-VCH high-wind cap).

**Note:** Simpson DuraVent pipe lengths can be added if required to meet clearance requirements.

The air intake pipe must be attached to the inlet air collar of the termination cap.

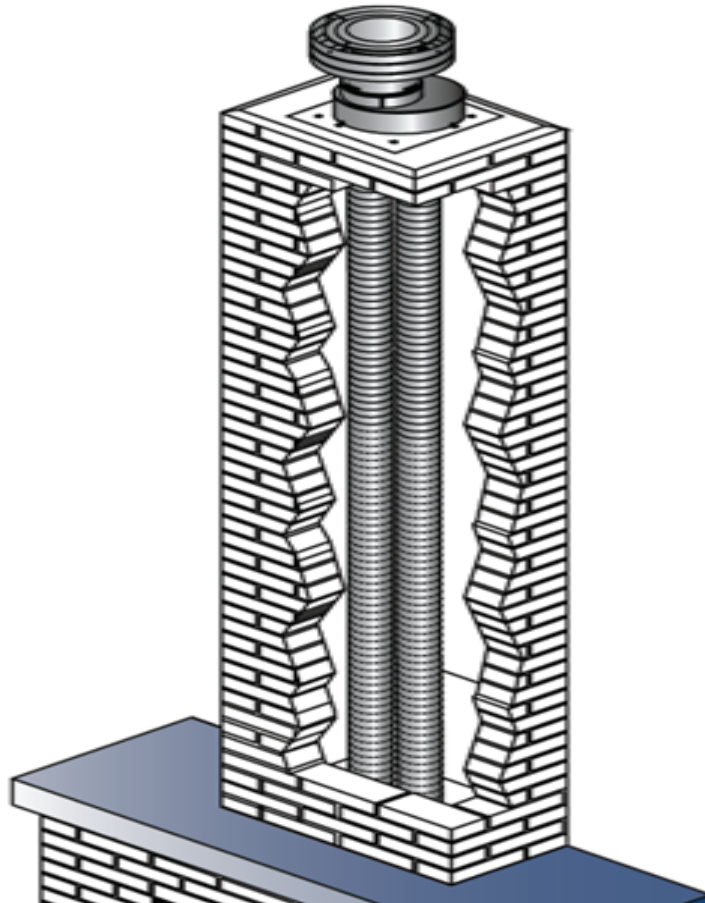

## Restrictor Adjustment

### Tools needed

- Phillips screwdriver

1. Gently lift the screen assembly up and out. Refer to the Screen Removal section.
2. Remove the glass door. Refer to the Glass Door Removal section.
3. Refer to the vent chart to determine the restrictor setting.
4. Locate the restrictor plates and screws.
5. Use a Phillips screwdriver to loosen or remove the four screws.
6. Adjust the restrictors according to the vent chart in this manual. The notches above the holes in the baffle will match the notches on the restrictor plate.
7. Tighten the screws. Setting 1 requires one screw for each restrictor.

	Opening size
Setting 1	1"
Setting 2	2-1/2"
Setting 3	2"
Setting 4	4-1/2"

Setting 1

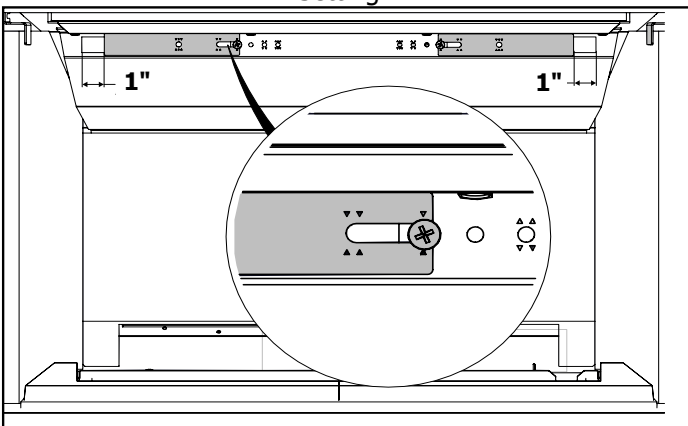

Setting 3

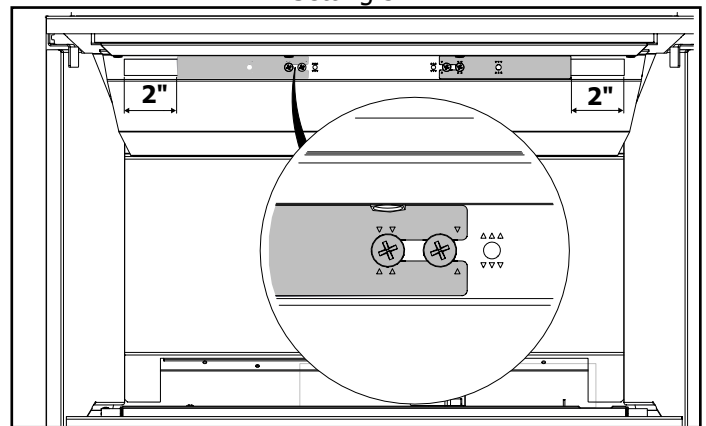

Setting 2 (Factory Setting)

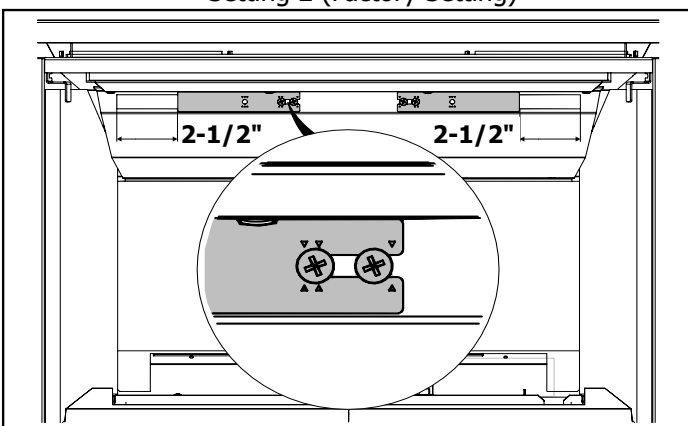

Setting 4

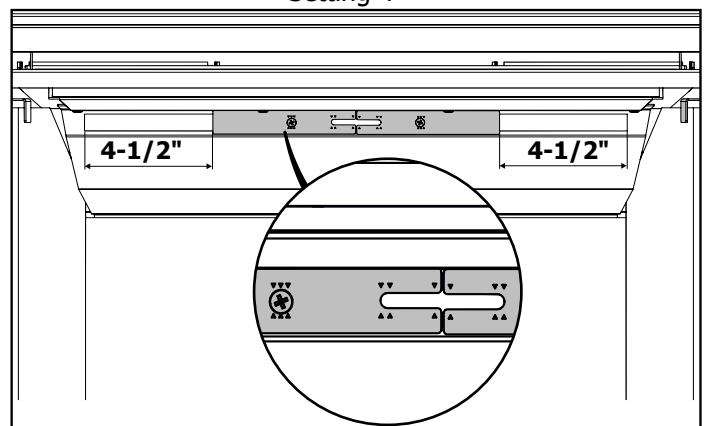

# installation

## Vertical Venting/Restrictor Settings for NG and LP

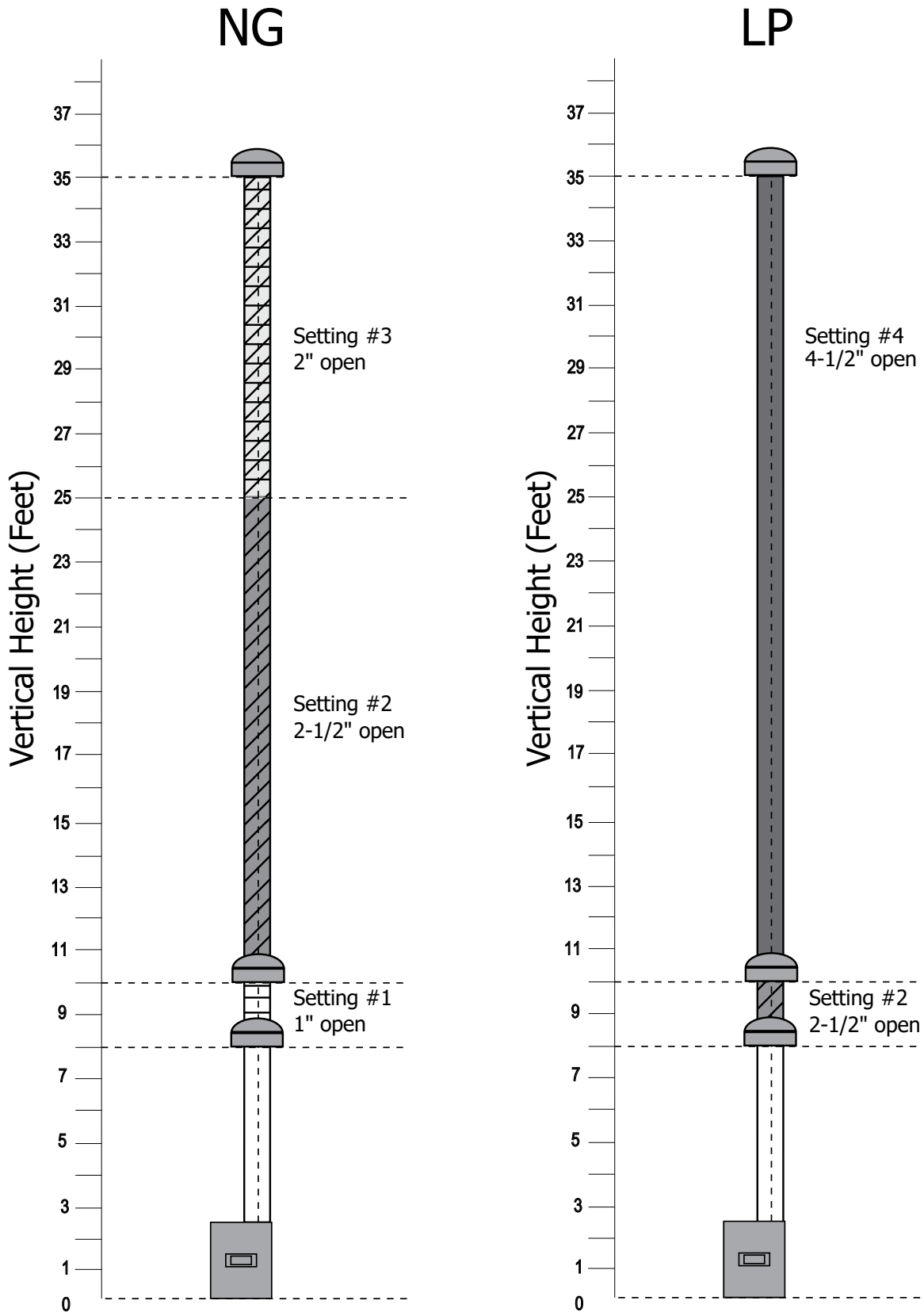

**Vertical Venting/Restrictor Settings for FPI Co-Linear DV Vertical Termination Cap & Flashing (946-529) Enclosed**

**IMPORTANT:**

Vent cap clearances to Sides and Top must be followed.

See next page for important clearance requirements when termination cap is enclosed above and on 2 sides.

Not approved for use with either the 46DVA-CL33 or 46DVA-GK + 46DVA-VCH Termination Caps/Adaptor

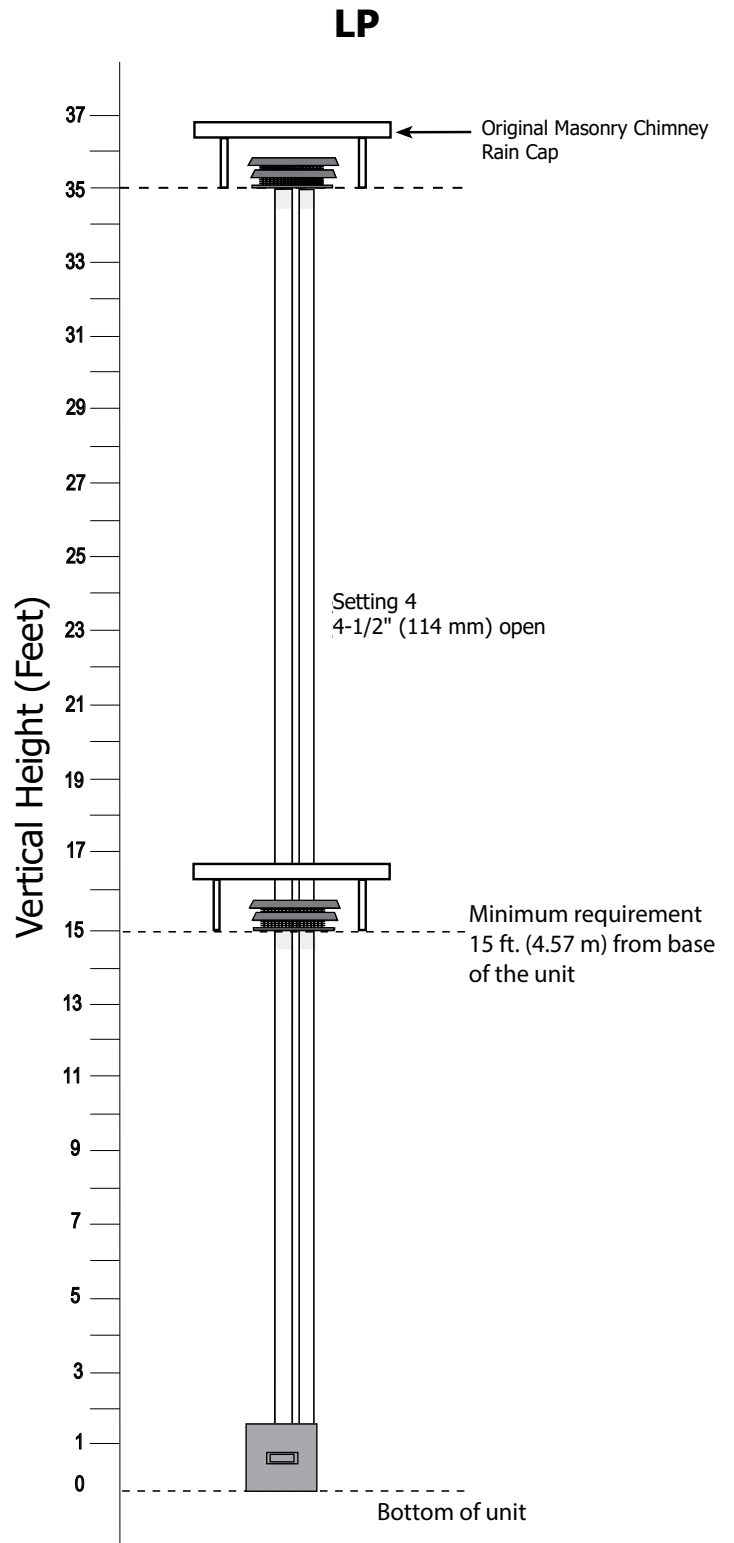
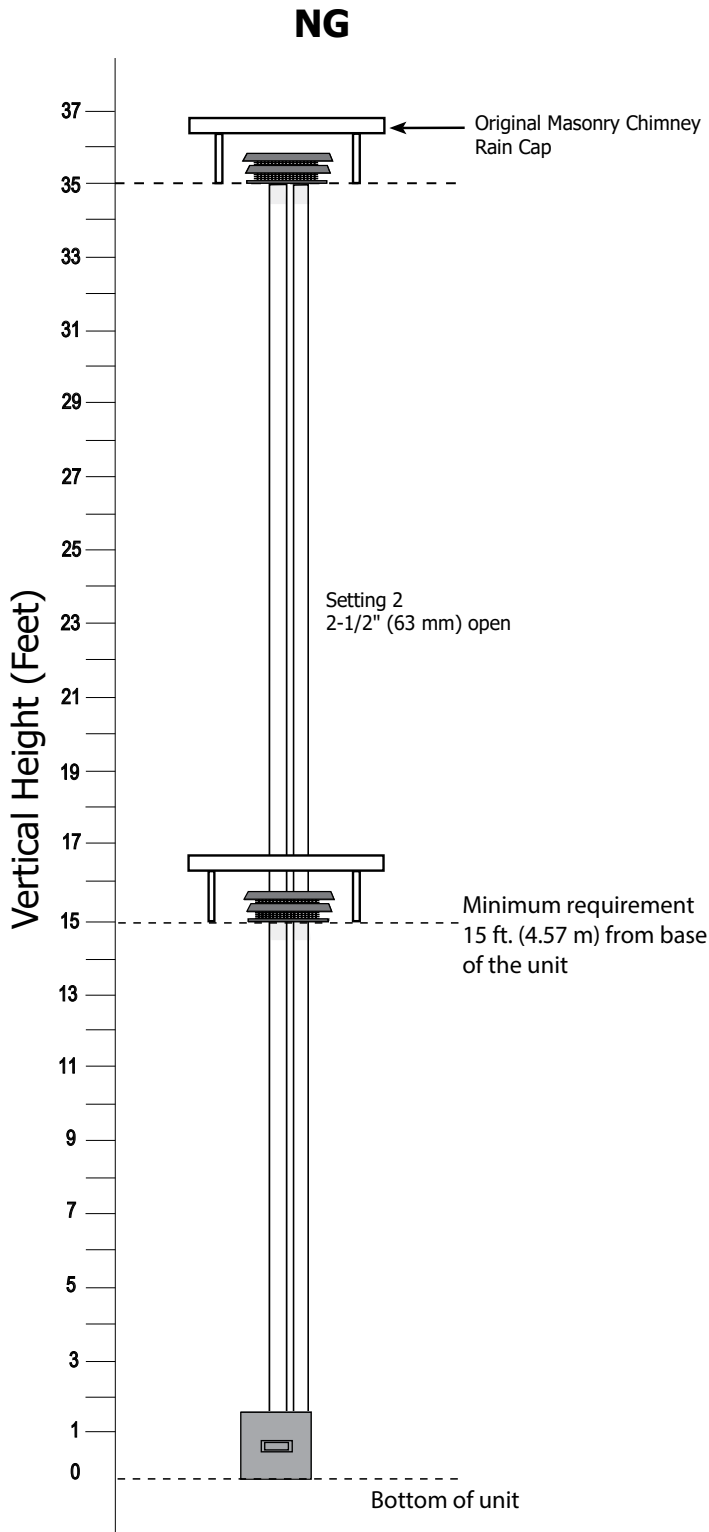

# installation

## Vertical Venting/Clearance Requirements for FPI Co-Linear DV Vertical Termination Cap & Flashing (946-529) Enclosed

When installed with 46DVA-CL33 or 46DVA-GK + 46DVA-VCH + 3" FPI Flex (Exhaust/Air Intake), the clearances below do not apply, all noted caps must be free and clear of obstructions on all sides.

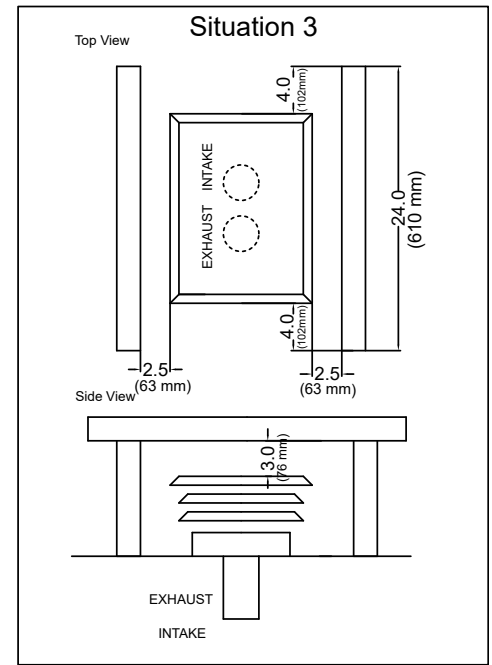
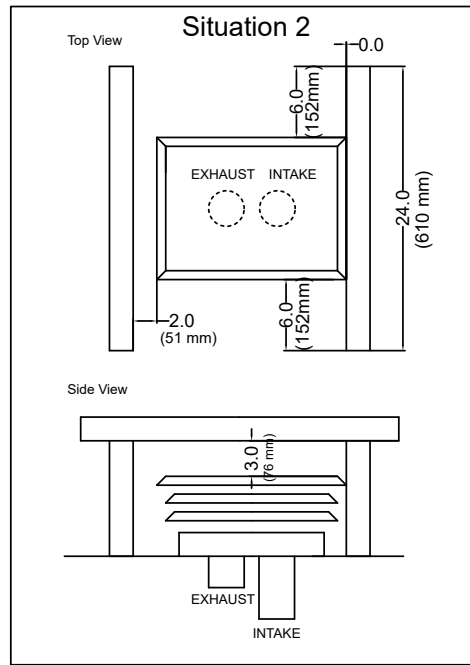
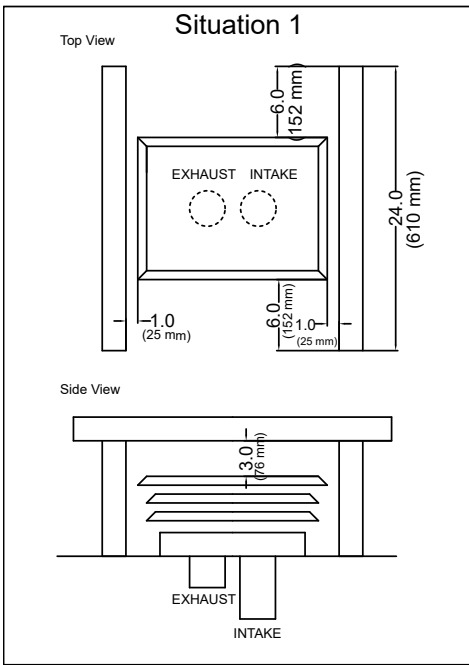

**Note:** Restrictor must be set to 2-1/2" (63 mm) open for NG or 4-1/2" (114 mm) open for LP.



## Horizontal Co-Linear Vent Kit (Masonry Fireplaces Only)

### APPLICATION

This instruction applies to the DuraVent Direct Vent Pro termination system and is intended as a supplement to the applicable Direct Vent Pro instructions. This termination and venting system and the gas appliance were tested and listed by an accredited test agency.

Kit # 46DVA-HCL33 includes:

1 Horizontal Termination Cap

Two 10' (3 m) long x 3" (76 mm) round liners and hardware.

The 948-128 Mill-Pac sealant must be purchased separately.

**NOTE** The intake and the exhaust are 3" (76 mm).

### INSTALL INFORMATION

The flue damper must be fully blocked open or removed if safe to do so for installation of the unit. Ensure the fireplace and chimney are clean and in good working order, and that all chimney cleanouts are tight-fitting and not permitting air into the chimney. Install a sealed vent cap and metal flashing at the top of the masonry chimney to prevent leaks and air movement within the cavity.

This appliance is only certified for use with NG when terminating horizontally (LP is not permitted). Make the hole on the outer portion of the masonry fireplace by boring it or removing bricks. Ensure that the masonry structure is safe and brick can be removed without damage to the chimney prior to proceeding. Minimum and maximum vent heights are noted below.

For complete instructions follow this link:

[https://duravent.com/wp-content/uploads/2020/06/L954-SUP\\_820018997-DirectVent-Pro-Horizontal-Vent-Kit\\_03-20-20\\_V1.pdf](https://duravent.com/wp-content/uploads/2020/06/L954-SUP_820018997-DirectVent-Pro-Horizontal-Vent-Kit_03-20-20_V1.pdf) [duravent.com]

**IMPORTANT** FPI is not responsible for the integrity of the masonry fireplace and or its repairs. Please consult with your local authorities.

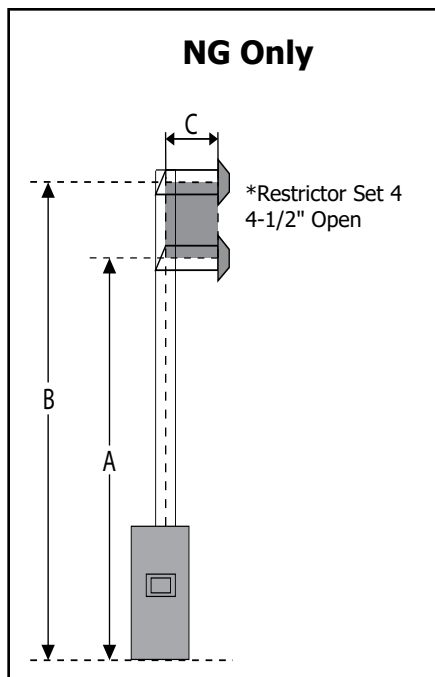

DIMENSIONS	
A - Min. Height	9 ft. (2.7 m)
B - Max. Height	10 ft. (3 m)
C - Max. Horizontal	18" (457 mm)

\*See page 19 for instructions on setting the restrictor.

**NOTE** The exhaust is located on the left side and the air intake on the right when facing the back of the termination as shown below. Seal the 3" (76 mm) flex with Mill-Pac, purchased separately.

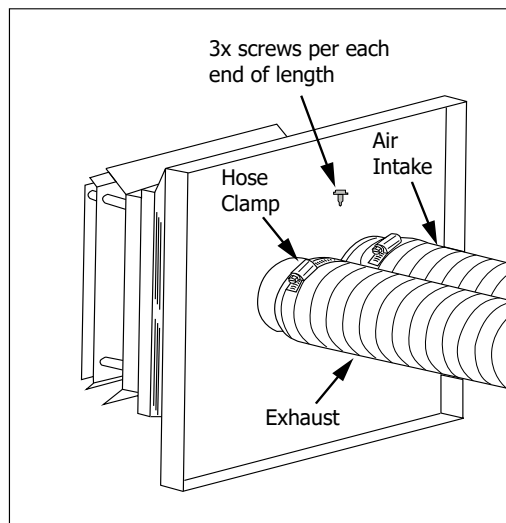

Installers must mechanically attach the supplied label to the inside of the firebox of the fireplace into which the gas fireplace insert is installed.

**NOTE** This fireplace has been converted for use with a gas fireplace insert only. It cannot be used for burning wood or solid fuels unless all original parts are replaced and the fireplace re-approved by the authority having jurisdiction.

# installation

## Flue Collar Installation/Removal

1. Detach the flue collar from the unit by removing the screws and sliding the plate backward.

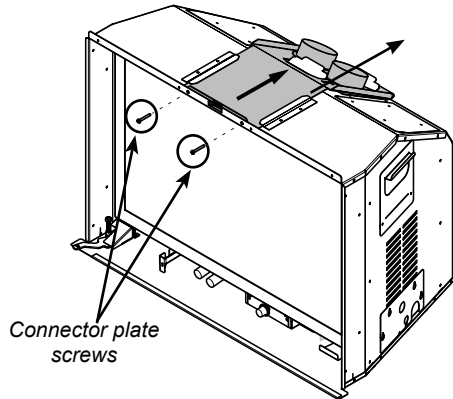

2. Attach the exhaust and intake flue liners to the flue collar with a minimum of three self-tapping screws. Use Mil-Pac sealant to seal pipes.

3. Pull the flue collar through the cutout in the top of the insert using the flue collar tool provided. See diagram 2.

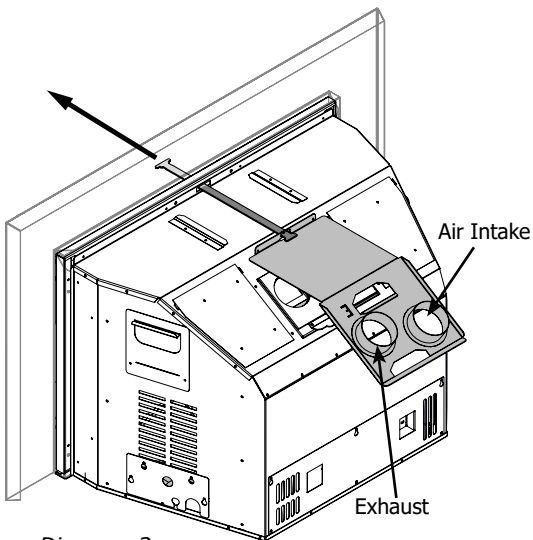

4. The tabs on the insert will seal the flue collar against the intake inlet and exhaust outlet. Secure with the two screws removed in step 1.

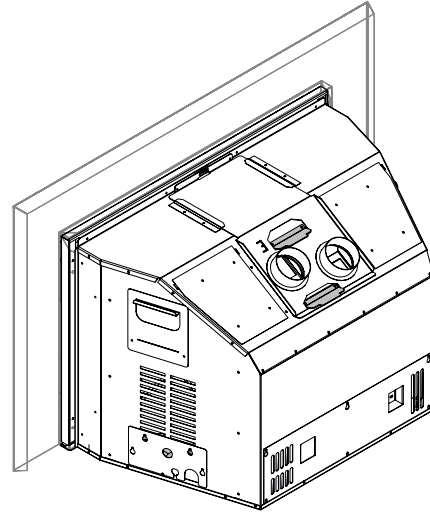

5. Tighten the two Phillips screws to secure the collar.

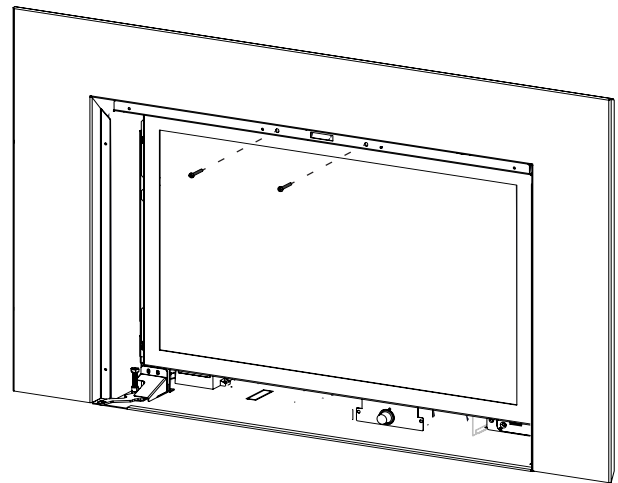

NOTE

Ensure the draft hood is properly secured and screws tight to create proper seal.

## Air Shutter Adjustment

The burner aeration is factory set, but may need adjustment due to altitude or the local gas supply.

Air shutters increase or decrease the amount of air mixed with fuel, affecting combustion and how the flame looks. Low primary air will create a taller, yellower flame, and higher primary air a lower, bluer flame.

Air shutter adjustment is not just for appearance - not enough primary air may lead to carboning, sooting, or a flame that reaches the top of the firebox. Units that are burning propane, installed at higher elevations, or run on high most of the time may need more primary air.

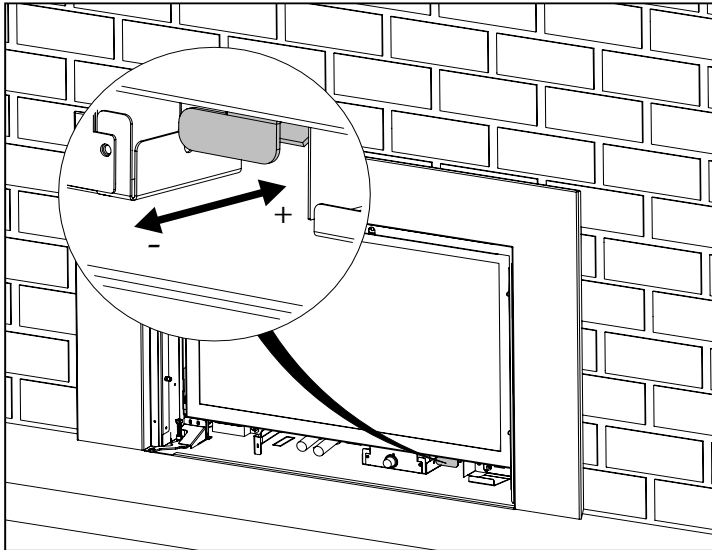

- Pull out to close air shutter
- + Pull in to open the air shutter

Unit	Fuel Type	Min. Air Shutter Setting*
Gi29LU	NG	3/16" (5 mm)
Gi29LU	LP	1/4" (6.35 mm)

\*At higher elevations, air shutter settings may have to be opened more to compensate.

CAUTION

- \*Carbon will be produced if the air shutter is closed too much.**
- Aeration adjustment should only be performed by an authorized Regency installer at the time of installation or service.**
- Any damage due to carboning resulting from improperly setting the aeration controls is NOT covered under warranty.**

# installation

NG System Data	
Min. Supply Pressure	5" WC (1.25kPa)
Low Setting Man. Pressure	1.1 WC (0.27 kPa)
Max. Manifold Pressure	3.8" WC (0.95 kPa)
Factory equipped for altitude 0-2000 ft. (0-610 m)	
Orifice Size	#38 DMS
Minimum Input	17,000 Btu/h (4.98 kW)
Maximum Input	31,500 Btu/h (9.22 kW)
Field convertible for altitude 2000-4500 ft. (610 m - 1,370 m) - use conversion kit #311-980	
Orifice	#39 DMS
Minimum Input	16,500 Btu/h (4.83kW)
Maximum Input	30,500 Btu/h (8.93 kW)

LP System Data	
Factory equipped for altitude 0-4,000 ft. (0-1,370 m)	
Min. Supply Pressure	11" WC (2.74 kPa)
Low Setting Man. Pressure	2.9 WC (0.72 kPa)
Max. Manifold Pressure	10.5 WC (2.61 kPa)
Orifice Size	#52 DMS
Maximum Input	31,500 Btu/h (9.22 kW)
Minimum Input	17,000 Btu/h (4.98 kW)

## High Elevation

This unit is approved for altitudes 0 ft. to 4,500 ft.

## Gas Line Installation

Some municipalities have local codes for gas line installation. Consult with your local authorities and the CSA B149.1 installation code.

For USA installations, follow local codes and the current National Fuel Gas Code, ANSI Z223.1.

When installing copper or flex connectors, use approved fittings only. Flare nuts for copper lines and flex connectors usually meet this requirement. Provide a union for easy disconnection of gas lines when servicing.

**NOTE** • A shutoff/Dante valve should be supplied in or near the unit (or as per local codes) for ease of servicing this appliance.

**IMPORTANT** • **Always check for gas leaks with a soap and water solution or gas leak detector. Do not use open flame for leak testing.**

## Pilot Adjustment

Periodically check the pilot flames. A correct flame pattern has two strong blue flames: one flowing around the flame sensor and one flowing across the burner (it does not have to be touching the burner).

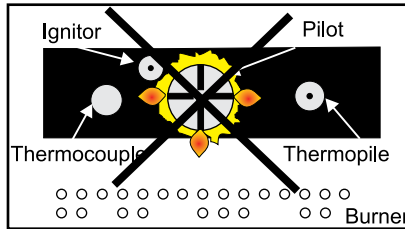
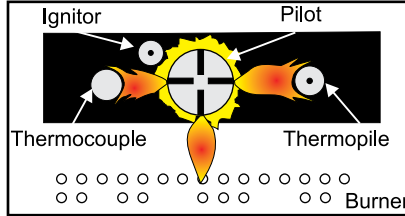

**NOTE** If you have an incorrect flame pattern, contact your Regency® dealer for further instructions.

An incorrect flame pattern will have small, probably yellow flames, not coming into proper contact with the rear burner or flame sensor.

## Gas Pipe Pressure Testing

It is necessary to isolate the unit from the gas supply piping system prior to gas pipe pressure testing. Close the unit's manual shutoff valve during testing at pressures equal to or less than 1/2 psig. (3.45 kPa). Disconnect the piping from the valve at pressures over 1/2 psig.

The manifold pressure is controlled by a regulator built into the gas control and should be checked at the pressure test point.

**NOTE** • To properly check gas pressure, both inlet and manifold pressures should be checked using the valve pressure ports on the valve.

1. Make sure the unit is in the "OFF" position.
2. Loosen the "IN" or "OUT" pressure tap(s), turning counterclockwise with a 1/8" wide flat screwdriver.
3. Attach manometer to "IN" or "OUT" pressure tap(s) using a 5/16" ID hose.
4. Turn the unit on using the remote or wall switch.
5. Do the pressure check with the unit burning. The setting should be within the limits specified on the safety label.

6. When finished reading the manometer, turn off the unit, disconnect the hose, and tighten the screw clockwise with a 1/8" flat screwdriver.

**NOTE** The screw should be snug, but do not over-tighten.

## 820 Valve Description

1. Gas On/Off Knob
2. Manual High/Low Adjustment
3. Pilot Adjustment
4. Thermocouple Connection
5. Main Operator
6. Outlet Pressure Tap (Manifold Pressure)
7. Inlet Pressure Tap (Supply Pressure)
8. Pilot Outlet
9. Main Gas Outlet
10. Flange Securing Screw Holes
11. Alternative TC Connection Point
12. Thermoelectric Unit
13. Additional Valve Mounting Hole

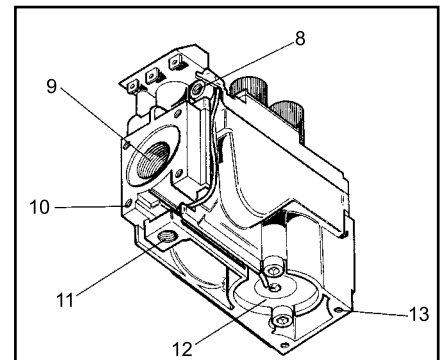
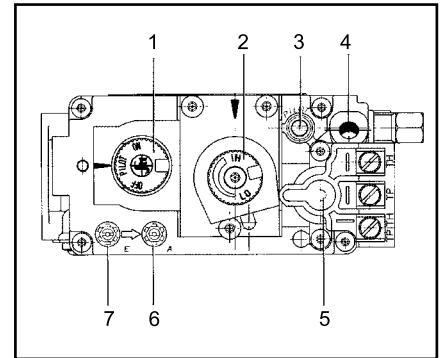

## Gas Shut Off Procedure

1. Slide the shut-off arm out.

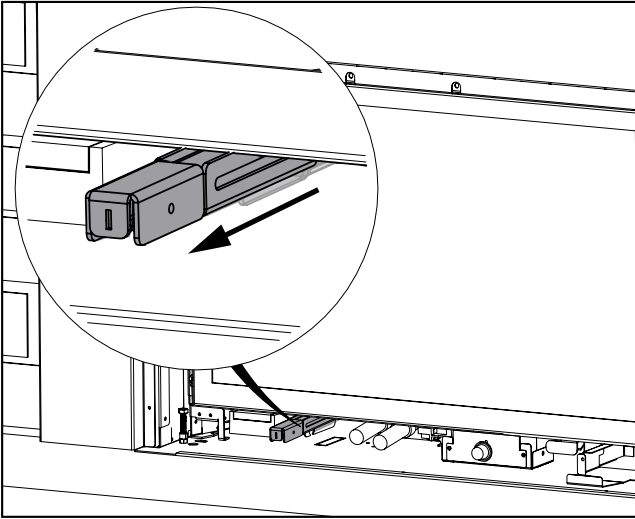

4. Slide shut-off arm back in.

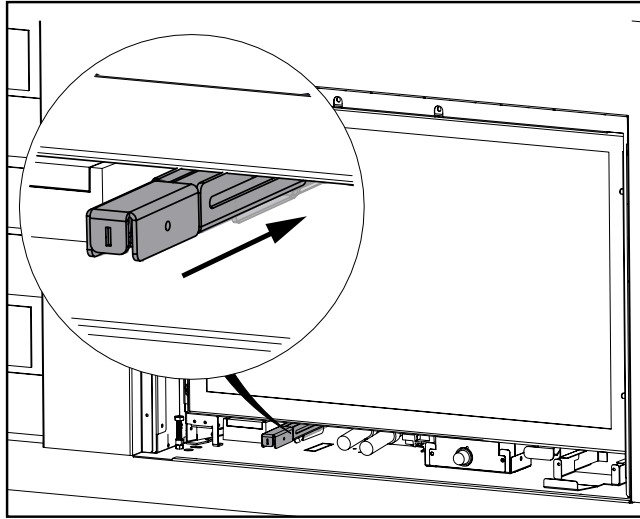

2. Turn gas valve to desired position. If needed, use a flathead screwdriver to turn valve.

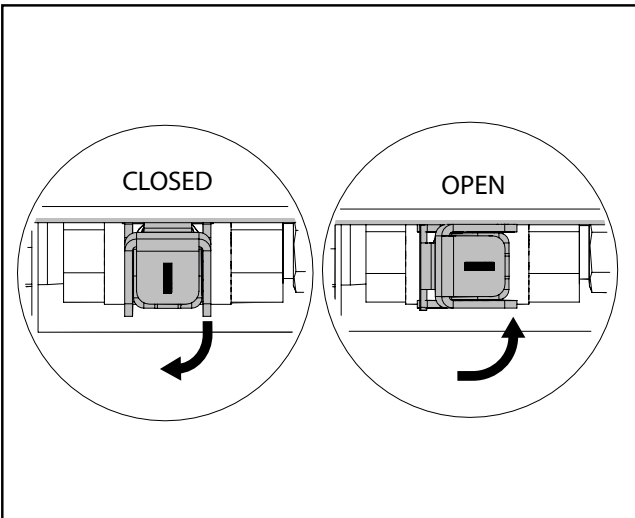

3. Alternatively, rotate the knob to turn it into a handle for more leverage. Clockwise closes the valve, counter-clockwise opens it.

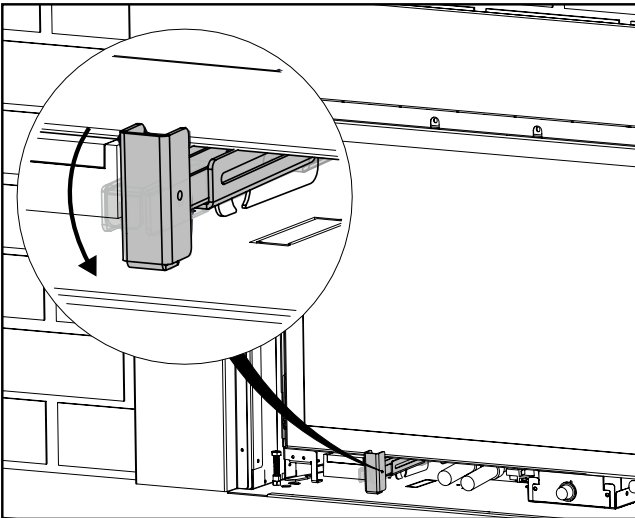

## Conversion from Natural Gas to Propane

**THIS CONVERSION MUST BE DONE BY A QUALIFIED GAS FITTER  
IF IN DOUBT DO NOT DO THIS CONVERSION !!**

**WARNING**  
This conversion kit shall be installed by a qualified service agency in accordance with the manufacturer's instructions and all applicable codes and requirements of the authority having jurisdiction. If these instructions are not followed exactly, a fire, explosion, or carbon monoxide may result, causing property damage, personal injury, or loss of life. The qualified service agency is responsible for the proper installation of this kit. The installation is not proper and complete until the operation of the converted appliance is checked.

Conversion Kit #311-977 includes:

1	905-064	Burner Orifice #52
1	910-037	Pilot Orifice #30
1	918-590	Decal - Conversion to LP
1	904-529	5/32" long Allen Key
1	908-528	Label Propane Red
1	920-432	LP Conversion Instructions

1. Turn the unit off and allow it to cool to room temperature.
2. Unplug or disconnect the stove power source.
3. Remove the safety screen and glass front (see manual).
4. Remove the logs and brick panels (if installed).
5. Remove the right rear log bracket (3 screws).

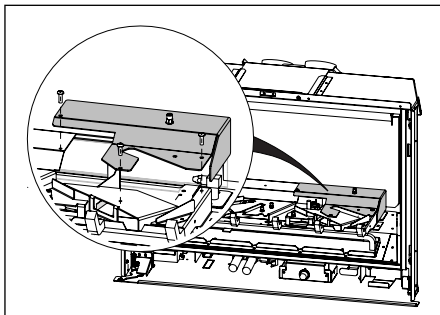

6. Remove the burner tray (2 screws).

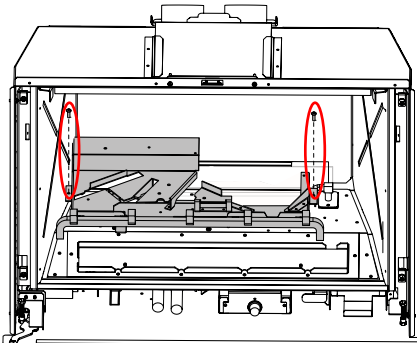

7. Slide the burner tray to the left and out.

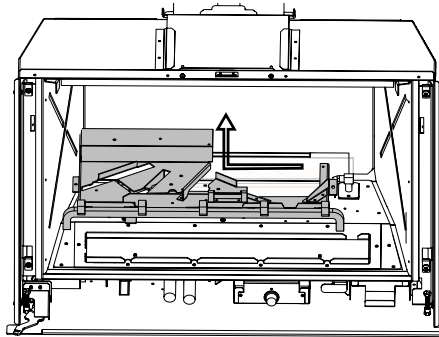

8. Pull off the pilot cap to expose the pilot orifice.



9. Unscrew the pilot orifice with the Allen key and replace with the LP pilot orifice in the kit and replace pilot cap.



10. Remove the burner orifice with a 1/2" wrench and replace it with the #52 orifice in the kit. Use another wrench to support behind the elbow when removing/replacing the burner orifice.

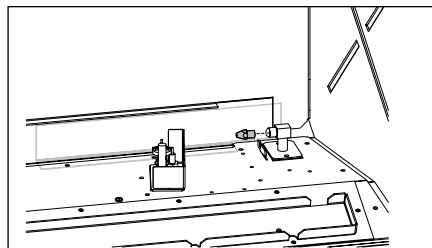

11. Turn the control knob to the "OFF" position.
12. Remove the black protection cap from the hi-low knob (Fig.1) by hand.

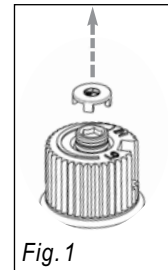

13. Insert a 5/32" or 4mm Allen wrench into the hexagonal keyway of the screw (Fig. 2); rotate it counter-clockwise until it is free and extract it.

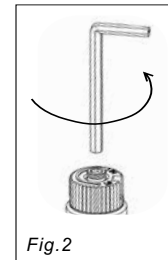

14. Check that the screw is clean.
15. Flip the screw (Fig. 3).

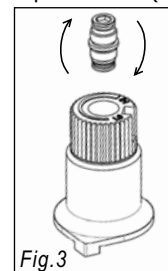

16. Using the Allen wrench as shown in Fig.4, rotate the screw clockwise until snug; do not overtighten.

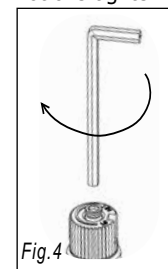

**WARNING** • **Do not over tighten the screw. Recommended to grip the wrench by the short side.**

17. Verify that if the conversion is from NG to LP. The screw must be reassembled with the red o-ring visible (Fig. 5).

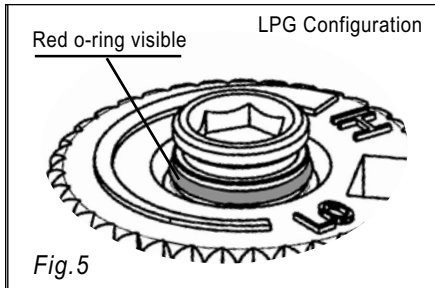

18. Reassemble the black protection cap (Fig. 6).

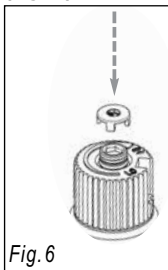

**WARNING** • **Also check that the pilot and main burner injectors are appropriate for the gas type.**

19. Reverse steps 4 to 2.
20. Attach the "This unit has been converted to LPG" label near or on top of the serial decal.
21. Replace the yellow "Natural Gas" label with the red "LPG" label.
22. Adjust the aeration settings - see the "Air Shutter Adjustment" section in this manual.
23. Start the appliance (see the "Lighting Instructions" section in this manual). Ensure that pilot and burner ignition are completed without delay. Check your inlet and outlet pressures at full load. With a soapy solution, leak test the entire system. Verify correct flame and pilot appearance.

**THIS CONVERSION MUST BE DONE BY A QUALIFIED GAS FITTER  
IF IN DOUBT DO NOT DO THIS CONVERSION !!**

**WARNING**

This conversion kit shall be installed by a qualified service agency in accordance with the manufacturer's instructions and all applicable codes and requirements of the authority having jurisdiction. If these instructions are not followed exactly, a fire, explosion, or carbon monoxide may result, causing property damage, personal injury, or loss of life. The qualified service agency is responsible for the proper installation of this kit. The installation is not proper and complete until the operation of the converted appliance is checked.

**Derate Kit #311-980 includes:**

1	905-069	NG Burner Orifice #38
1	920-465	Decal BTU Converted to 30,500
1	920-464	Derate Kit Instruction Sheet

1. Turn the unit off and allow it to cool to room temperature.
2. Unplug or disconnect power source to stove.
3. Remove safety screen and glass front (see manual).
4. Remove logs and brick panels (if installed).
5. Remove the right rear log bracket (3 screws).

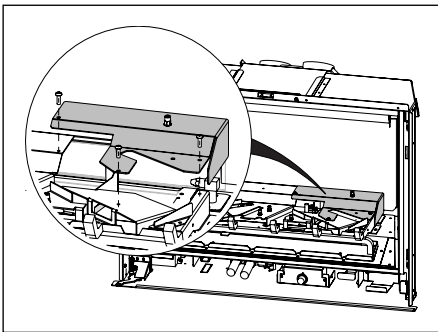

6. Remove the burner tray (2 screws).

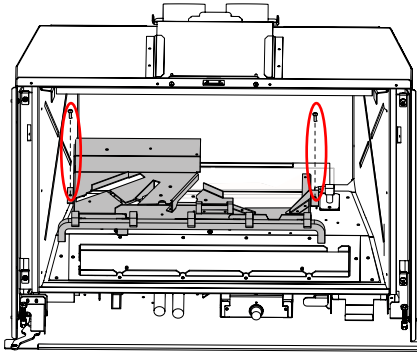

7. Slide burner tray to the left and out.

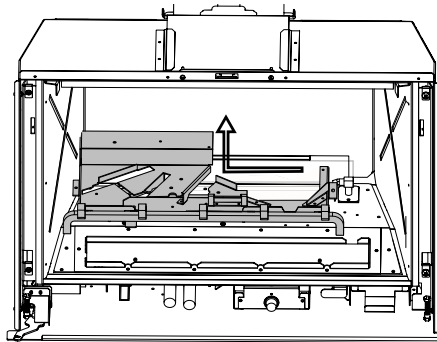

8. Remove the burner orifice with a 1/2" wrench and replace it with the #38 orifice in the kit. Use another wrench to support behind the elbow when removing/replacing the burner orifice.

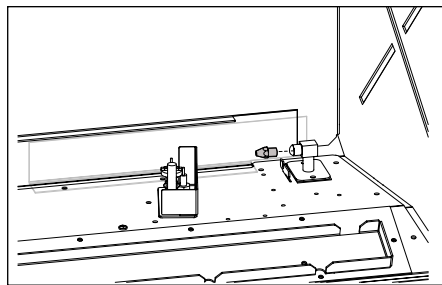

9. Reverse steps 7 to 2.

10. Attach clear label "This unit has been converted to 30,500" near or on top of the serial decal.

11. Adjust aeration settings - see Air Shutter Adjustment section in this manual.

12. Start the appliance (see Lighting Instructions section in this manual). Ensure that pilot and burner ignition are completed without delay. Check your inlet and outlet pressures at full load. With a soapy solution, leak test the entire system. Verify correct flame and pilot appearance.



## Panel Installation

**NOTES**

- Brick/steel/glass panels may discolor a little during operation. This is normal and should not be considered a defect.
- Black glass panels: All hand and fingerprints **MUST** be cleaned off with a soft cloth. Use an ammonia-based cleaner (i.e. glass cleaner) to remove prints before applying heat to the unit. Failure to do this will result in stains which you will be unable to remove - this issue is not covered by our product warranty.

1. Carefully remove the panels from the box. They are fragile - handle with care and do not force them into position. If installed, remove the glass front prior to installing the panels.

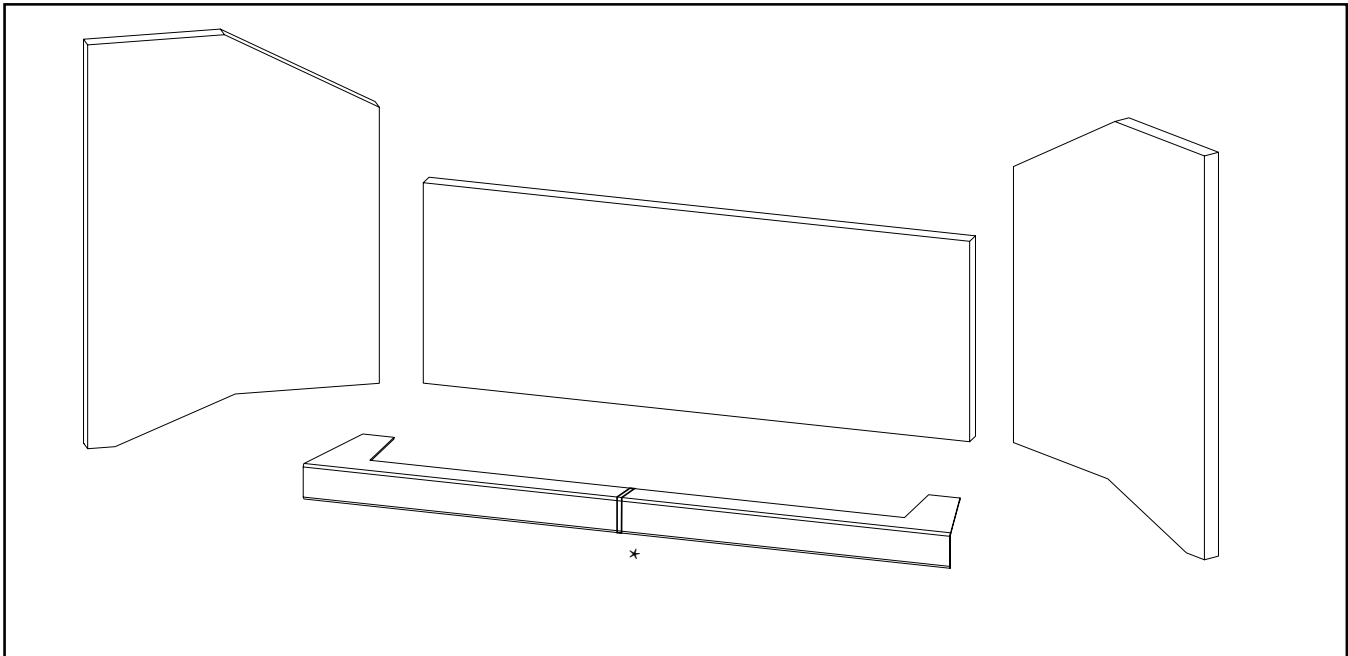

\*The front panel in the steel/black glass panel set is a single part. The front panel in the brick panel set is split into two parts.

2. Loosen screws and remove brick retainer brackets.

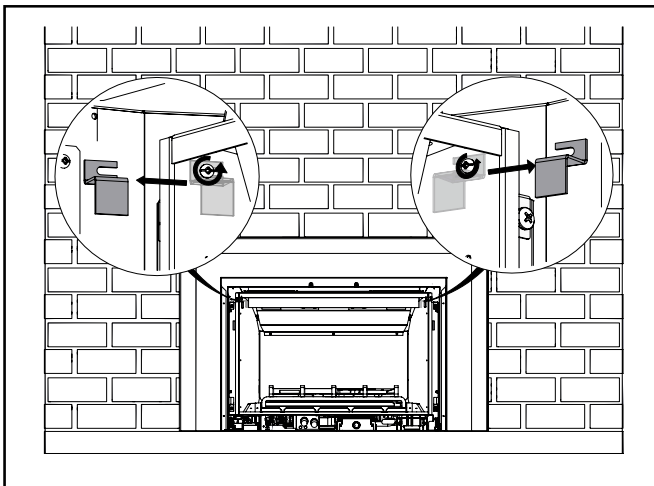

3. Insert the rear panel and hold in place while installing the left and right panels.

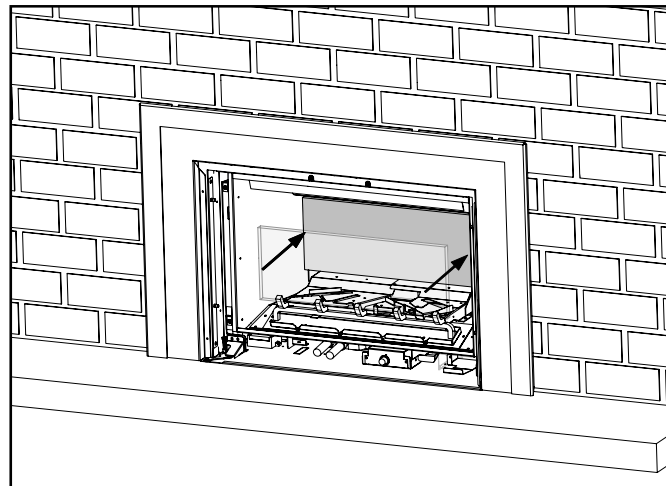

**NOTE**

- The brick panel sets must be installed with the arrow on the back of the panel pointing up to align the grout lines.

\*The glass panel set (311-906) must be installed with the smaller tabs on the top.

# installation

## **For brick/steel panels:**

4. Insert the left panel and push until it touches the rear panel.

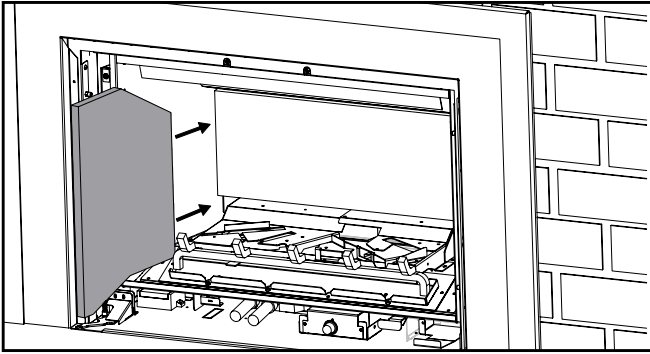

5. Insert the right panel and push until it touches the rear panel.

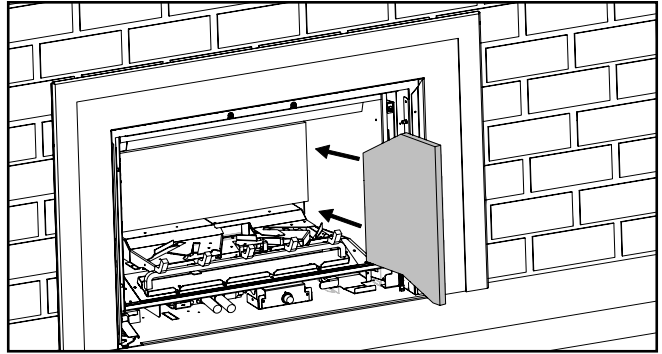

## **For glass panels:**

6. Rotate the left panel and push it in until it touches the rear panel.

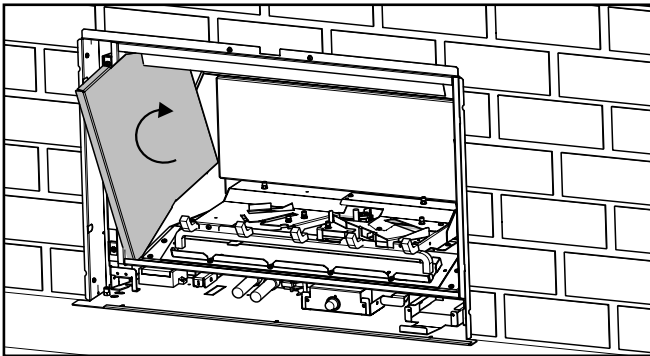

7. Rotate the right panel and push it in until it touches the rear panel.

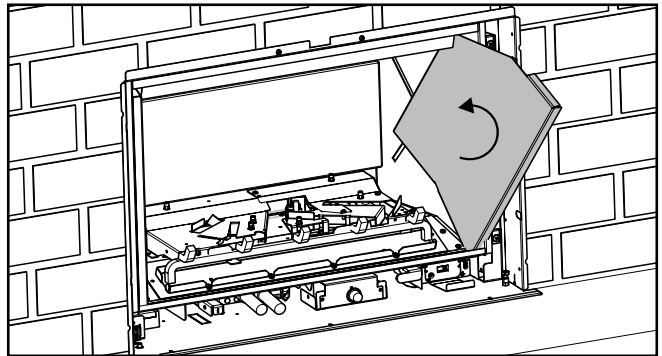

8. Install the brick retainer clips and tighten the screws. Note: The glass panel set (311-906) has its own panel retainers supplied in the box.

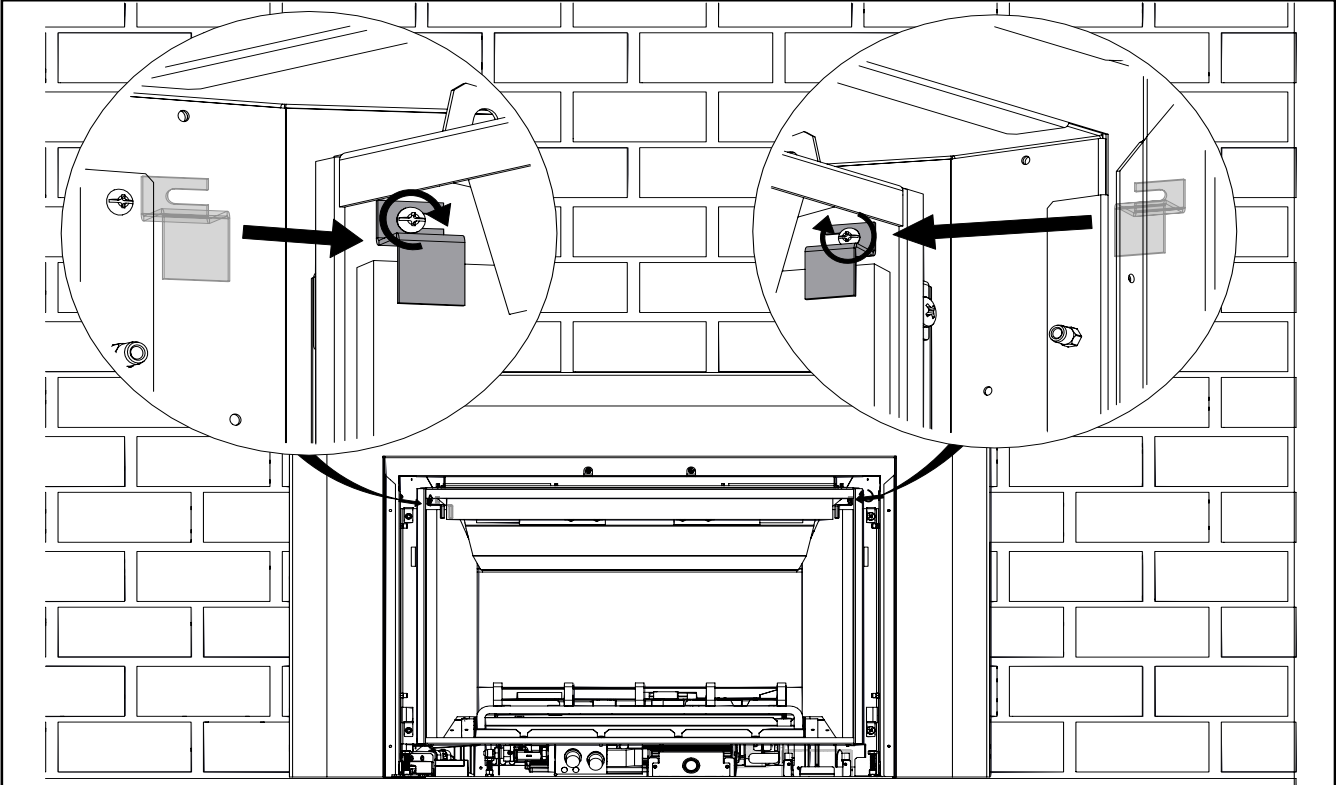

9. Install the front panel(s)\* by placing between the front of the firebox and the media tray. If the front panel is too tight, there are adjustment slots on the media tray to allow for looser fitting. Loosen the two screws on the media tray and slide it backward or forward as needed. Tighten the screws once the media tray is in the desired location.

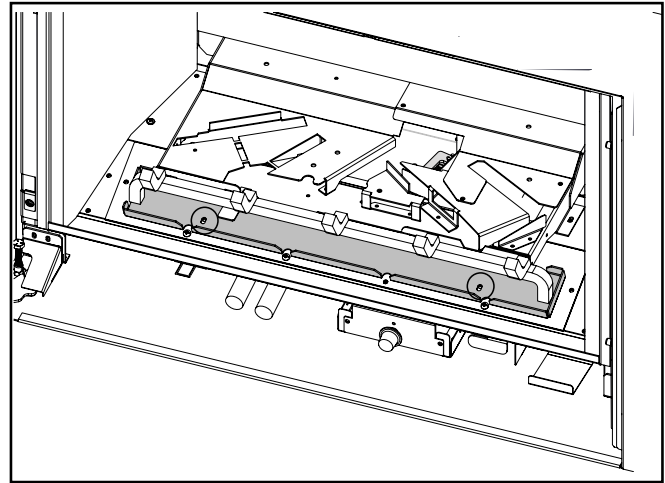
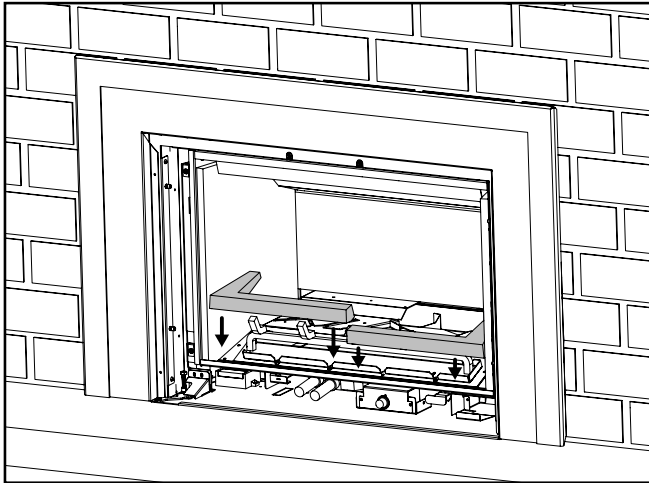

- NOTE**
- \*The front panel in the black steel/black glass panel set is a single part. The front panel for the brick panel set is split into two parts.
  - Front panel is not required if driftwood log set is being installed.

10. Final installation.

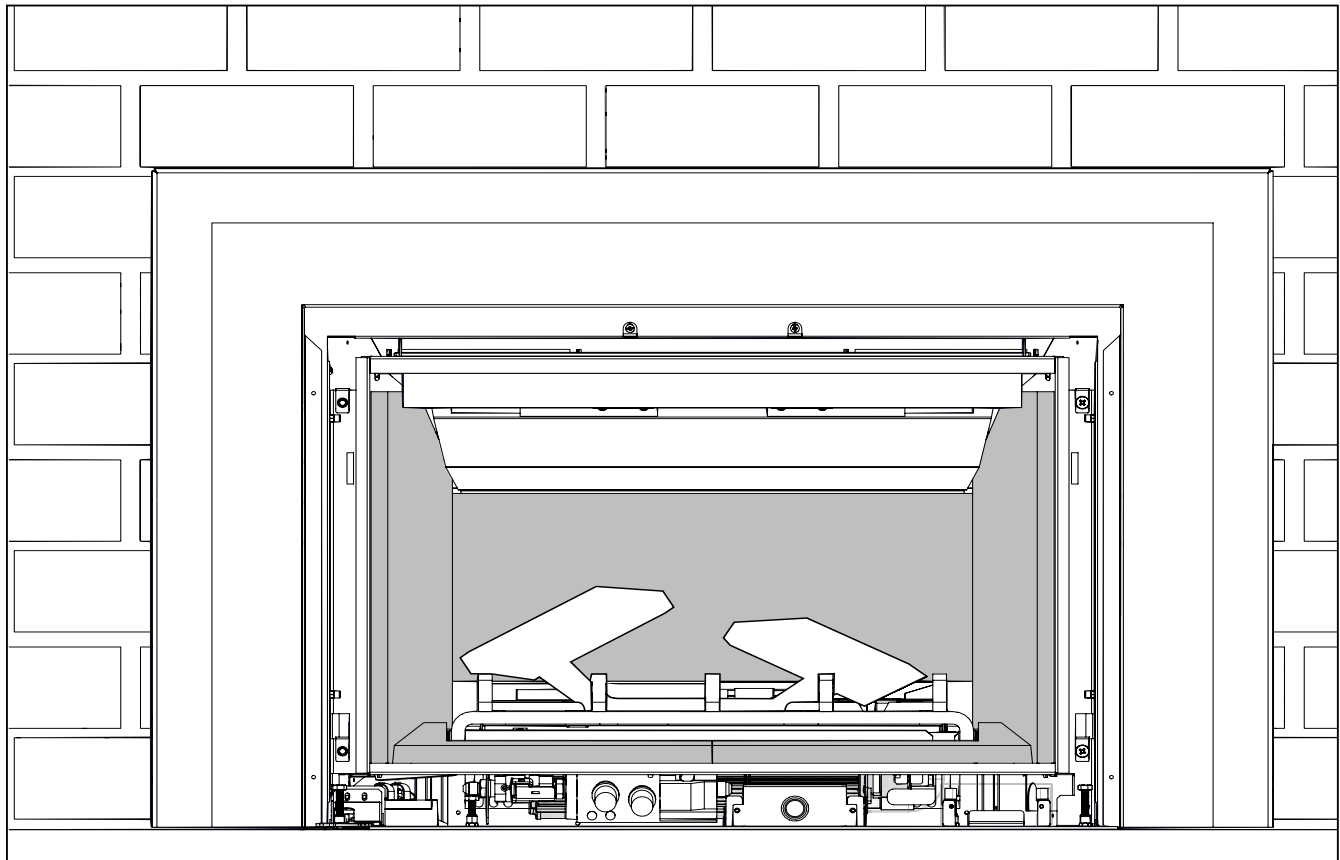

# installation

## Birch & Oak Log Set Installation (Part #311-931 & 311-934)

**IMPORTANT**

Read the instructions below carefully and refer to the images. If the logs are broken, do not use the unit until they are replaced. Improper positioning of the logs and may create carbon build-up and can alter the unit's performance. Issues caused by improper log positioning are not covered under warranty.

Prior to installing the log set, install the brick, painted, or glass panels.

**This log set includes:**

1	Rear log
2	Rear left log
3	Rear right log
4	Rear left center log
5	Rear right center log

6	Front left log
7	Front centre log
8	Front right Log
9	Top right log
10	Top left log

<b>Accessories:</b>
1 bag of Andriron embers
Vermiculite black sea wool
2.5 lbs 3/4" crushed glass
16 pieces of black/white embers
1 Log Grate

1. Carefully remove the logs from the box and unwrap them. The logs are fragile - handle with care, and do not force them into position.

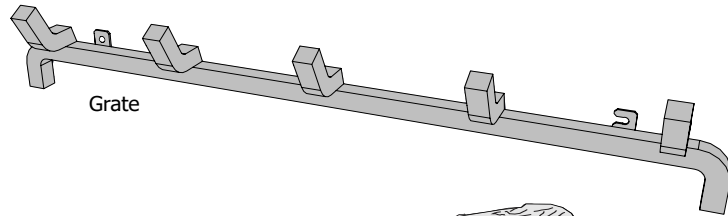

Grate

**NOTE** The Birch log set (311-931) will look slightly different than shown in the picture.

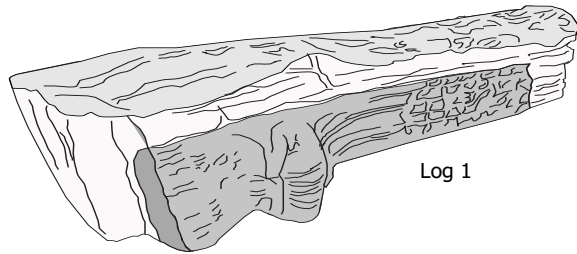

Log 1

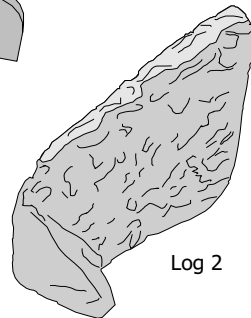

Log 2

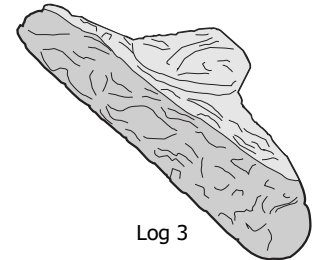

Log 3

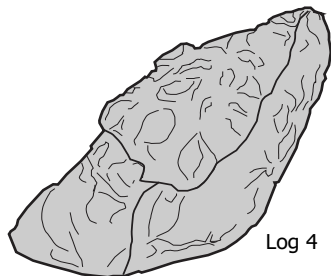

Log 4

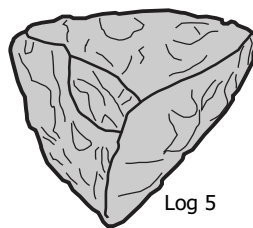

Log 5

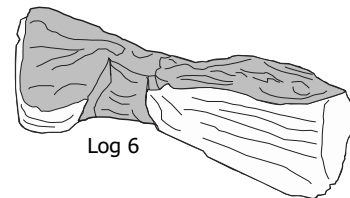

Log 6

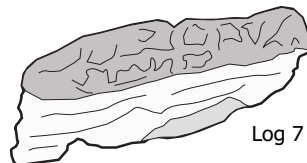

Log 7

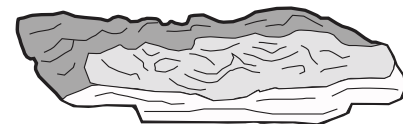

Log 8

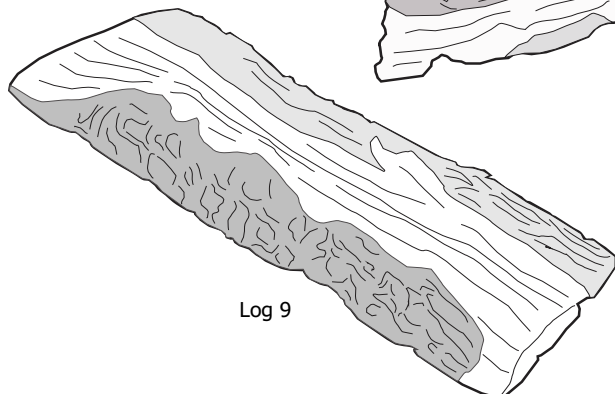

Log 9

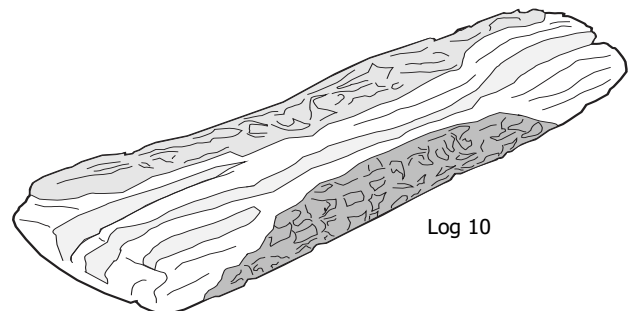

Log 10

2. Install the log grate with the two screws provided.

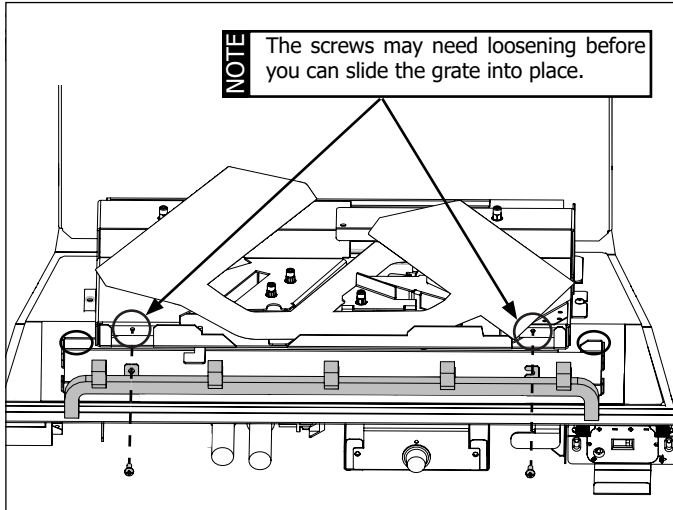
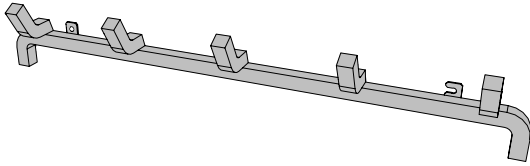

3. Evenly disperse black embers on each side of the burner tray. Ensure the embers sit below the burner tray, so that they do not interfere with logs 2 & 3.

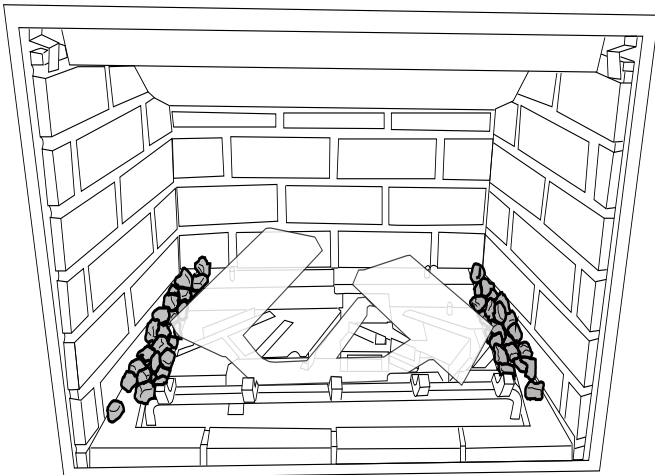

4. Fill the media tray with approximately 2lbs of the 3/4" glass, then scatter the black sea vermiculite on top. The glass can cover parts of the front brick panel.

**NOTE** There will be extra glass if you are installing a Gi29L or Gi29LU.

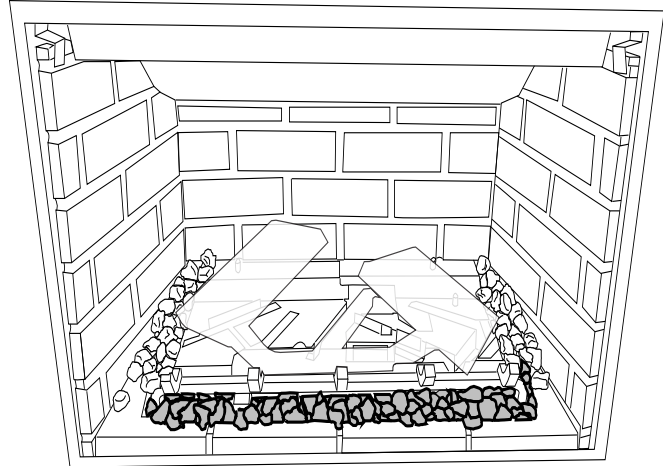

5. Spread the black/white embers along the front panels. When logs 6, 7, and 8 are installed, ensure the embers are not preventing proper log placement. It is also possible to add the embers after all logs are placed.

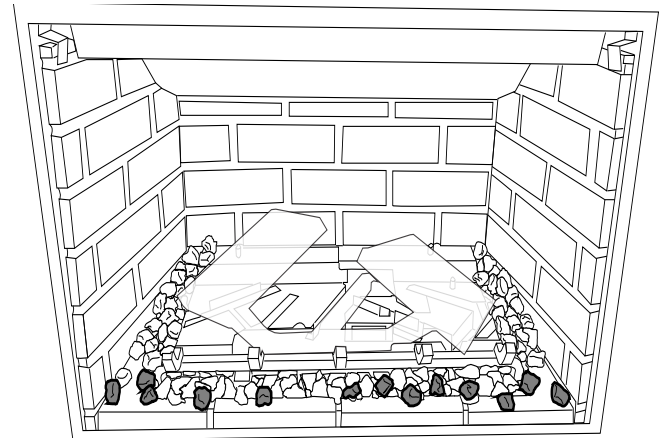

# installation

6. Carefully lay Log 1 on the two pins behind the burner. Make sure the left part of the log does not hit the left portion of the burner.

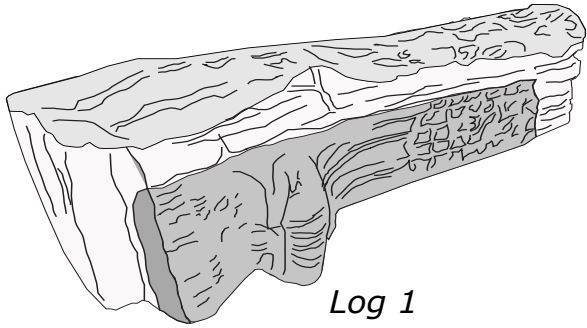

**NOTE** The Birch log set (311-931) will look slightly different than shown in the pictures, but the numbering is the same.

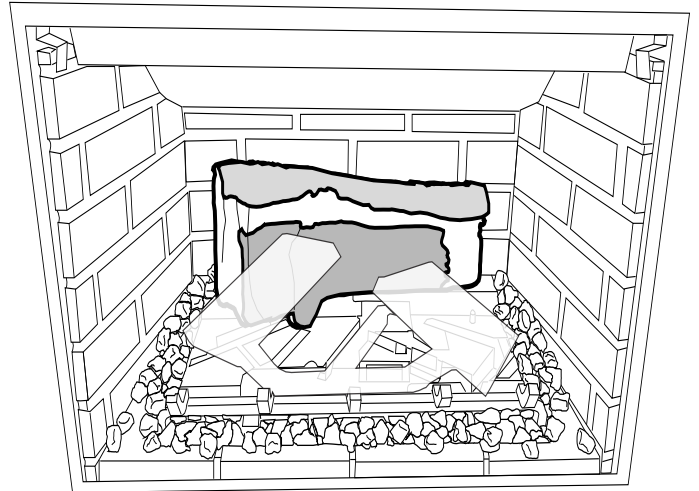

7. Place Log 2 behind the left portion of the burner, resting its right side in the notched area on Log 1. Rotate the front of Log 2 onto the metal flange and ensure it is resting directly on the tray, with no embers underneath.

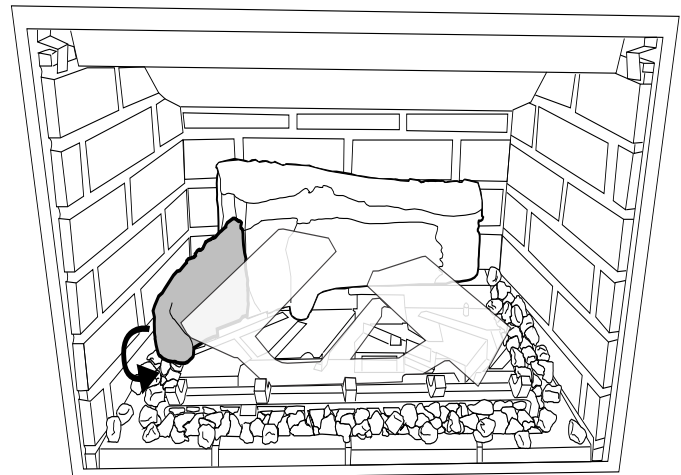
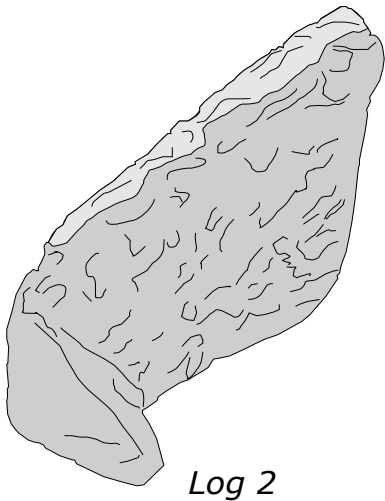

8. Place Log 3 on the pin and rotate it until it touches the tab shown below. Ensure that Log 3 is resting directly on the tray with no embers underneath.

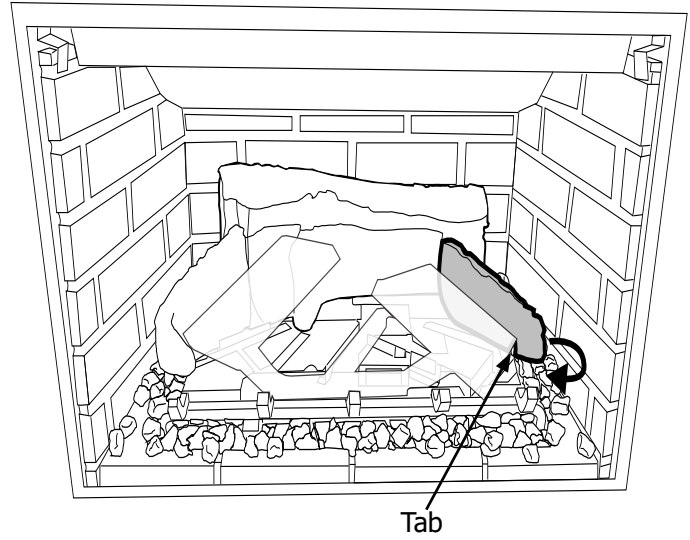
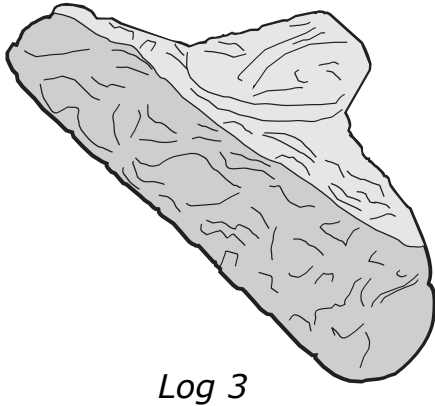

9. Place Log 4 on the two pins under the left burner.

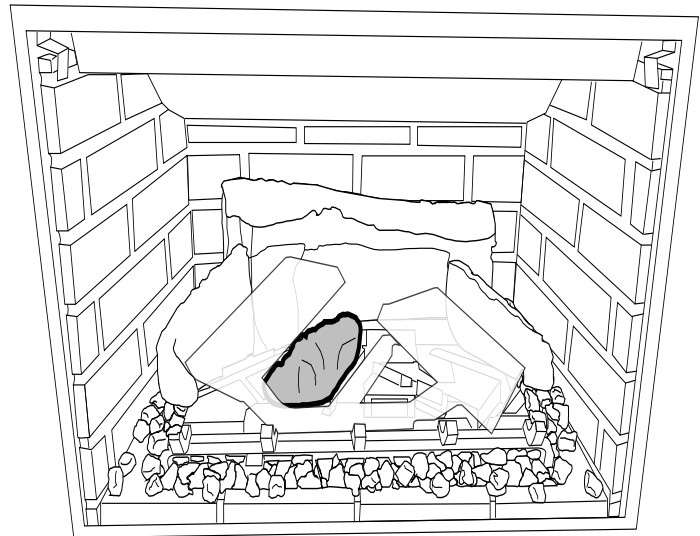
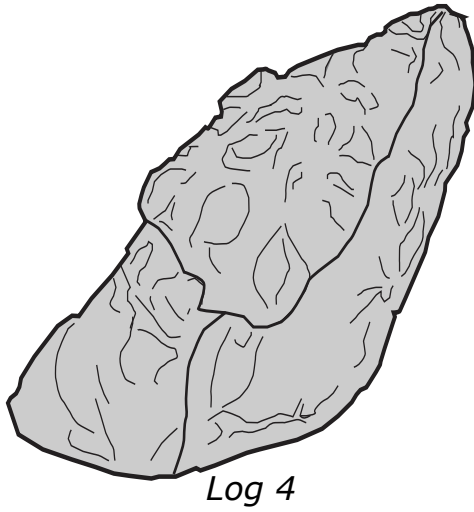

# installation

10. Place Log 5 on the pin under the right burner.

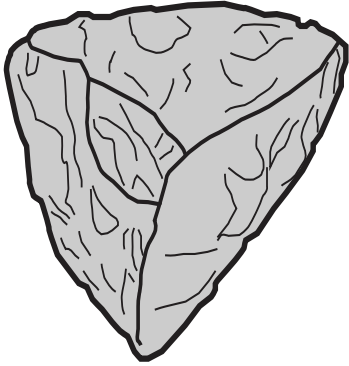

*Log 5*

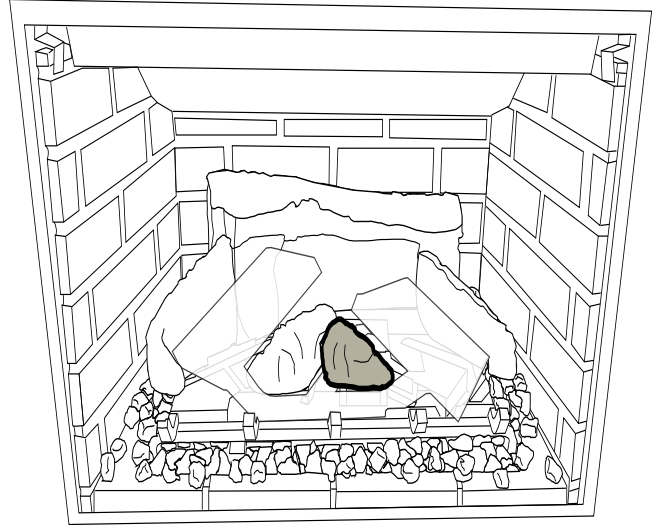

11. Place Log 6 on the grate with the notch on the middle of the log sitting on the first grate bar and the flat section pointing up. Log 6 does not sit on the front panel - it rests on the tab next to the second grate bar. Ensure that there are no embers underneath the log.

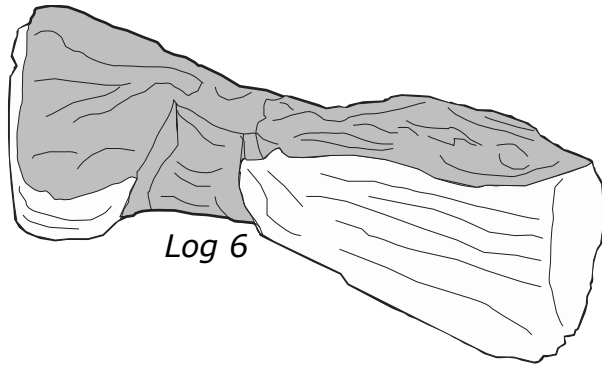

*Log 6*

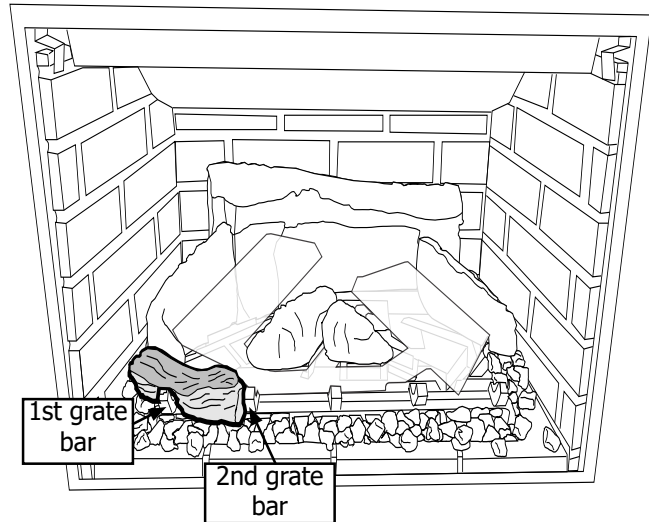



12. Place Log 7 with the notch (shown below) resting on the upper right corner of the second grate bar. Rest the bottom right end of the log on the front panel, ensuring it does not protrude over the bottom edge of the firebox and that there are no embers underneath. This ensures Log 7 sits properly on the grate and does not interfere with the operation of the glass door.

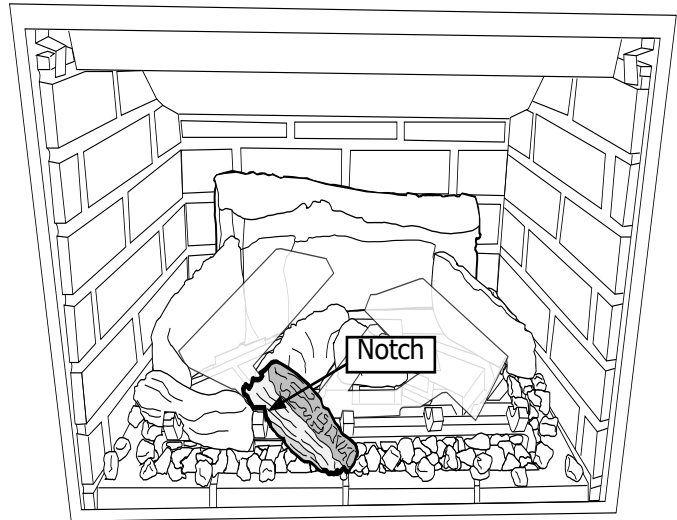
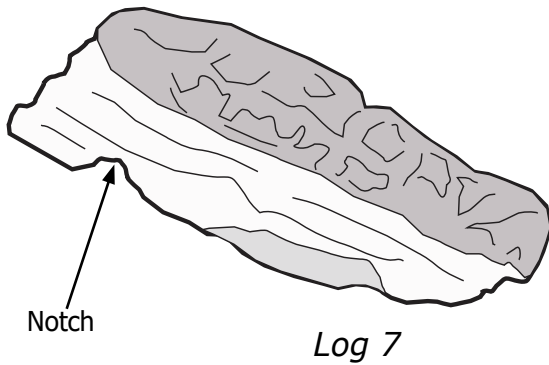

13. Place Log 8 between the third and fourth grate bar. The charred section at the top of the log faces the inside of the firebox.

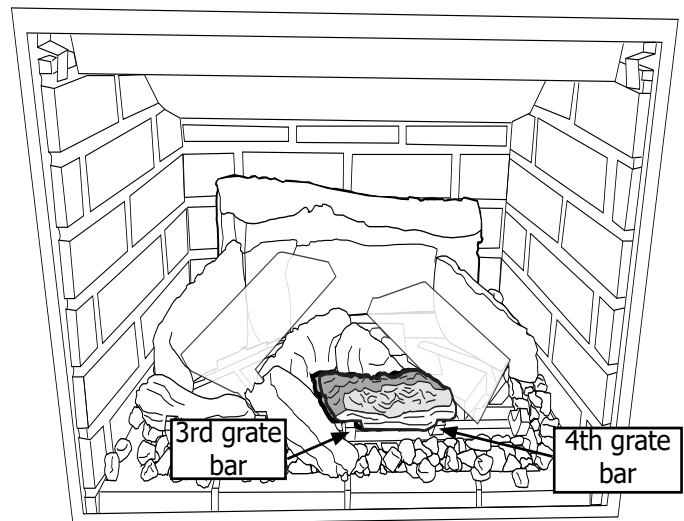
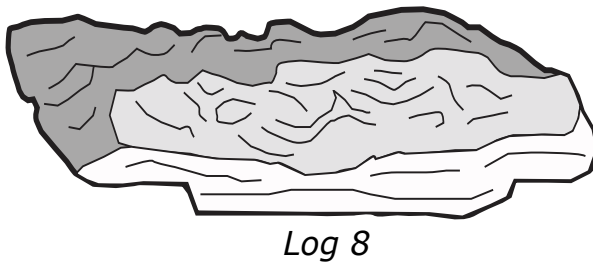

# installation

14. Place Log 9 on the right end of the burner. The log rests on the burner, not on the fifth grate bar.

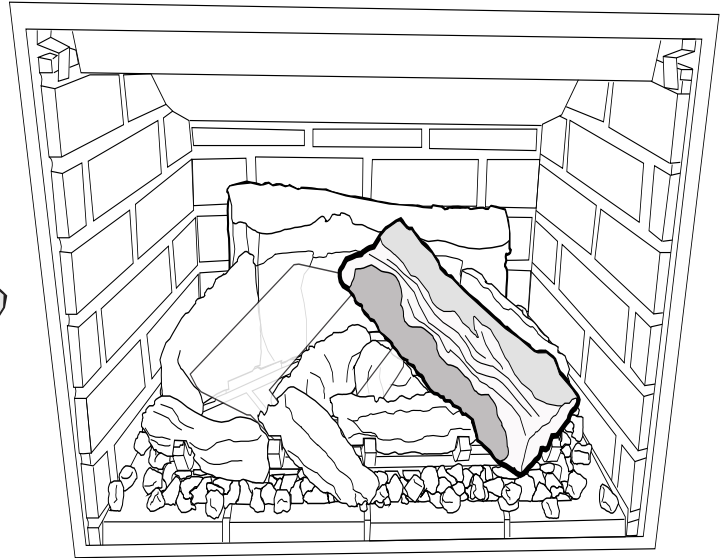
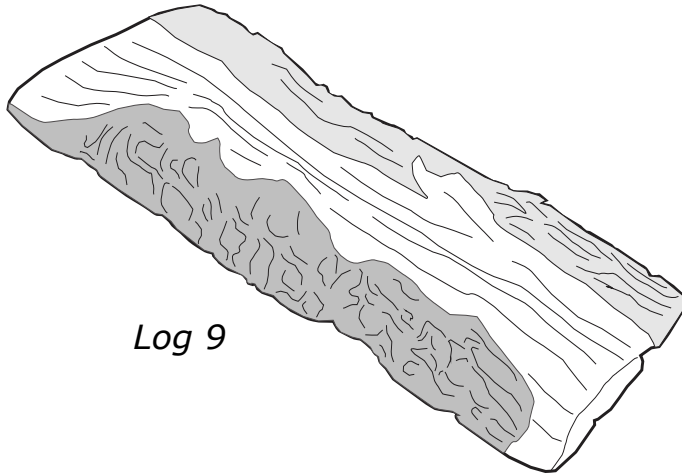

15. Place Log 10 on the left side of the burner. Log 10 should not touch Log 6. Readjust the positioning of Log 6 if necessary, ensuring it is resting on the tab beside the second grate bar.

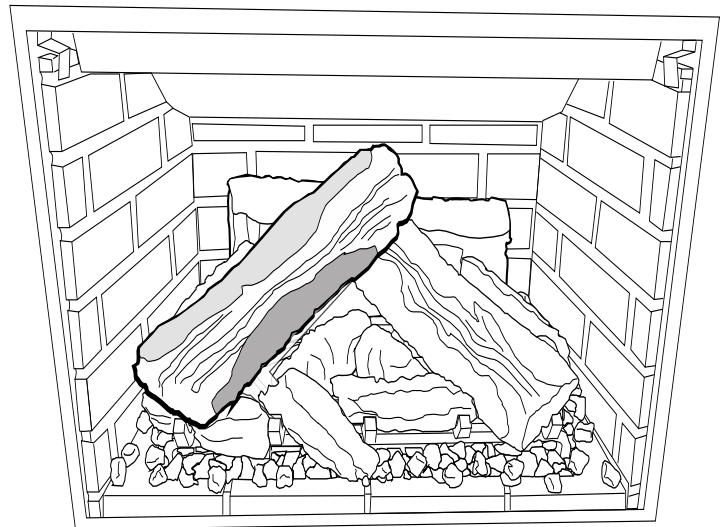
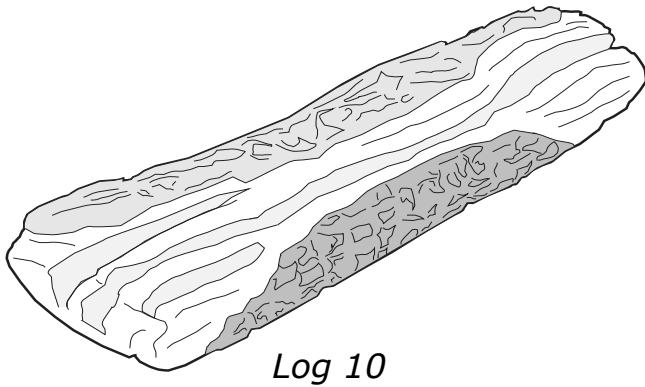

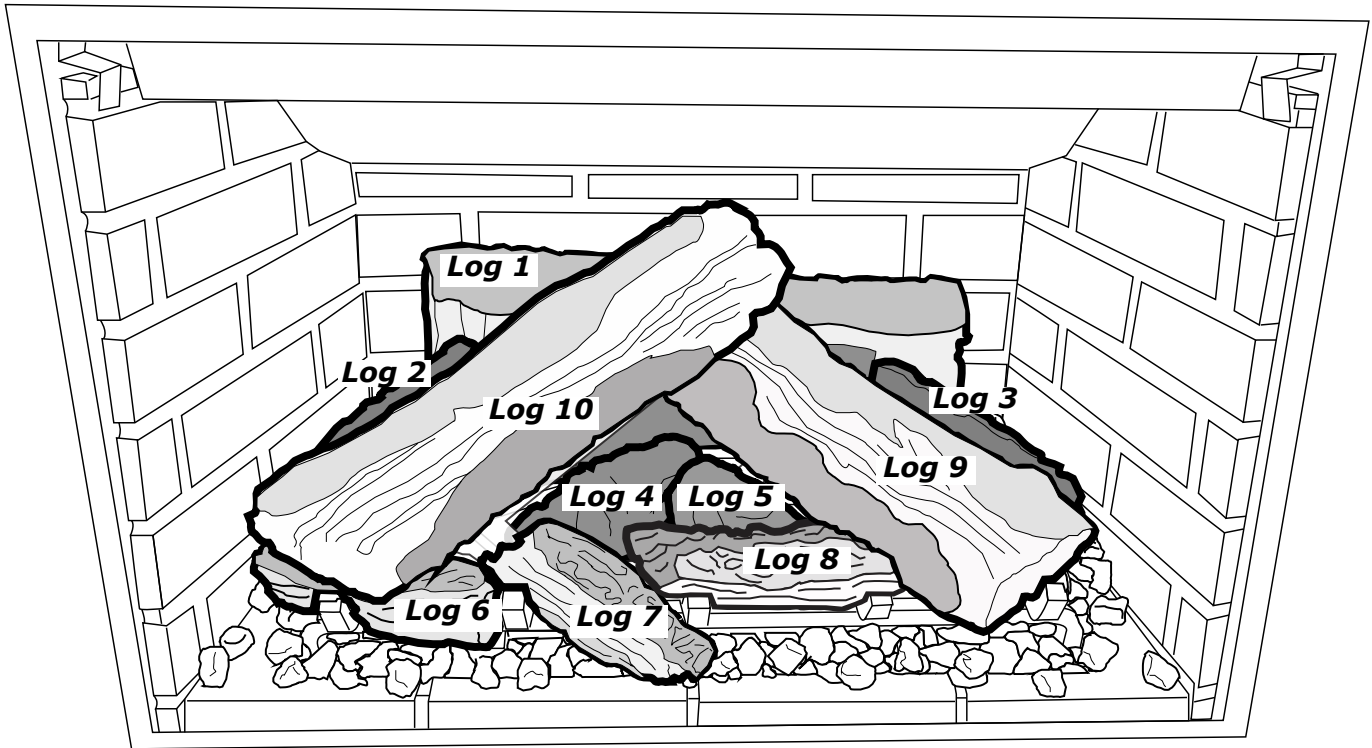

*Final Placement*

# installation

## Driftwood Log Set Installation (Part #311-930/P)

**IMPORTANT**

Read the instructions below carefully and refer to the images. If the logs are broken, do not use the unit until they are replaced. Improper positioning of the logs and may create carbon build-up and can alter the unit's performance. Issues caused by improper log positioning are not covered under warranty.

Prior to installing the log set, install the brick, painted, or glass panels.

This log set includes:

1	Rear Log
2	Rear Left Log
3	Rear Right Log
4	Rear Left Center Log
5	Rear Right Center Log

6	Top Left Log
7	Top Right Log
8	Front Log

<b>Accessories:</b>
1 Box of Andiron Embers
1 Box of 3/4" Crushed Glass
1 Front Log Mount

1. Carefully remove the logs from the box and unwrap them. The logs are fragile - handle with care, and do not force them into position.

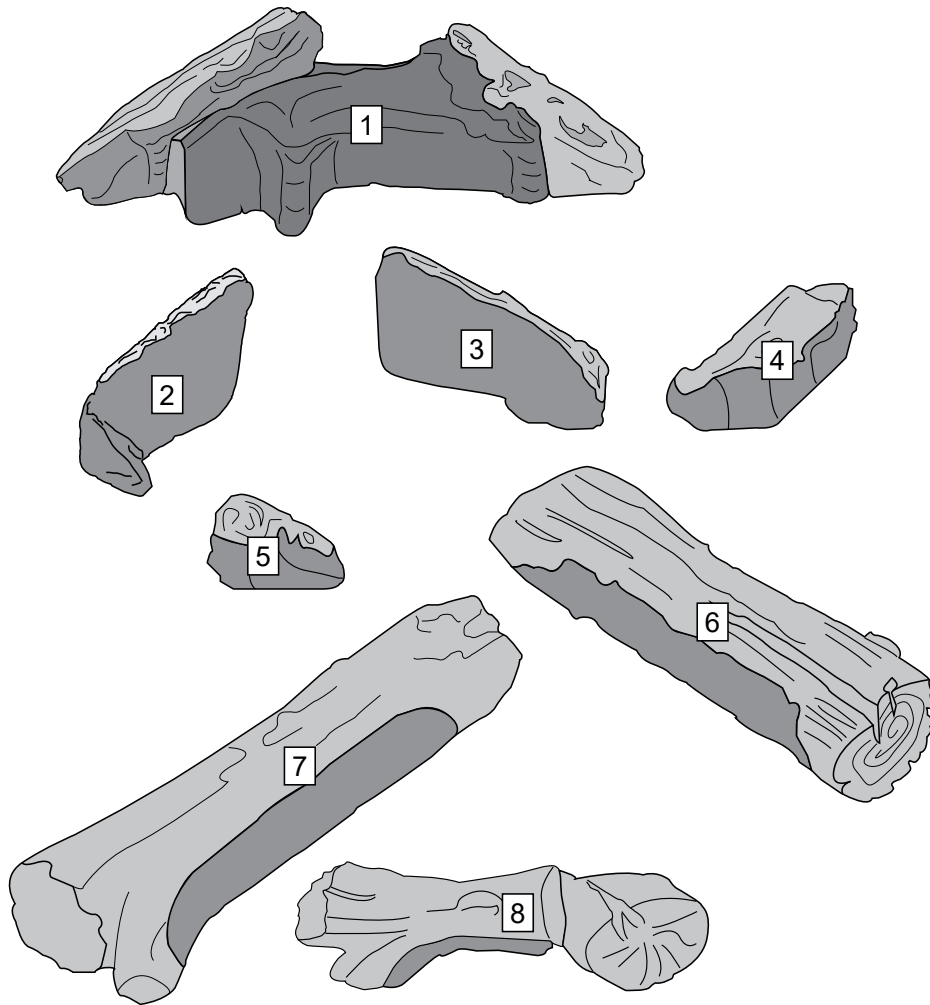

Front Log Mount



2. Remove pilot shield.

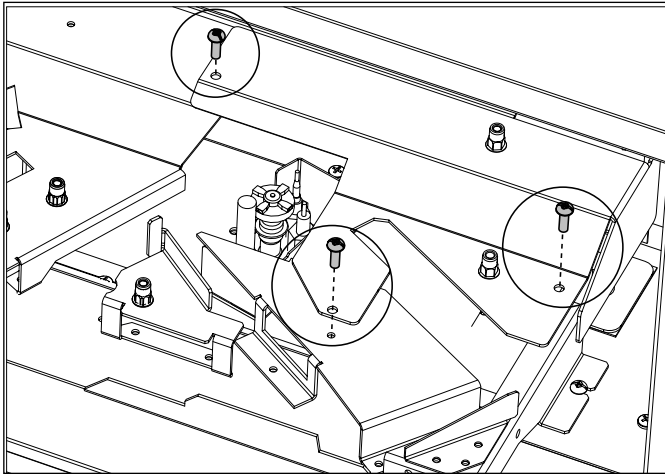

3. Remove 3 screws attaching the pilot shield to the burner tray.

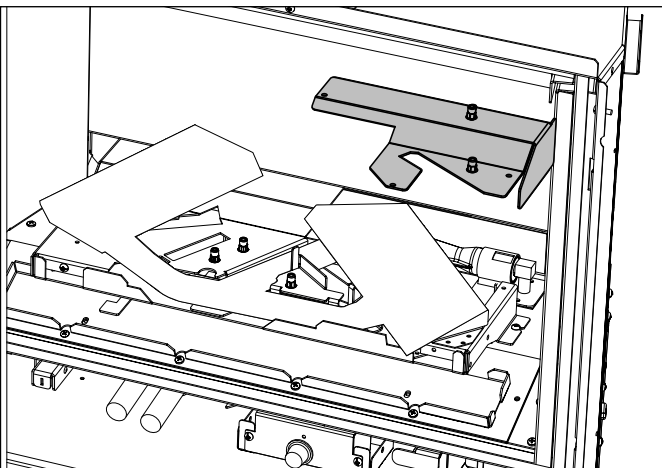

4. Remove the pilot shield.

5. Remove the two screws indicated.

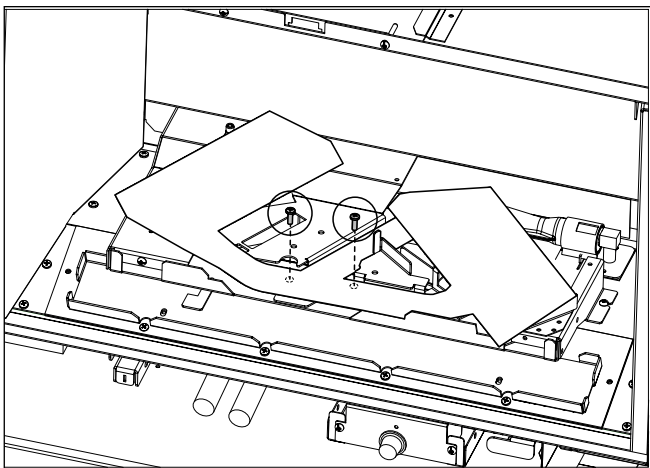

6. Remove the burner by sliding left and up out of the burner tray.

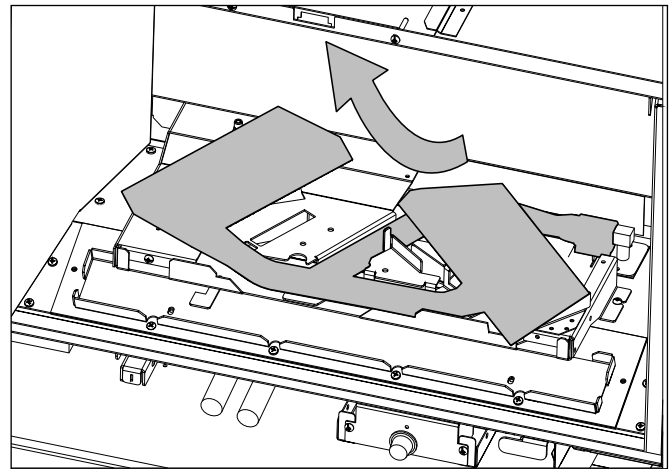

7. Install the Front Log Mount with one screw as shown.

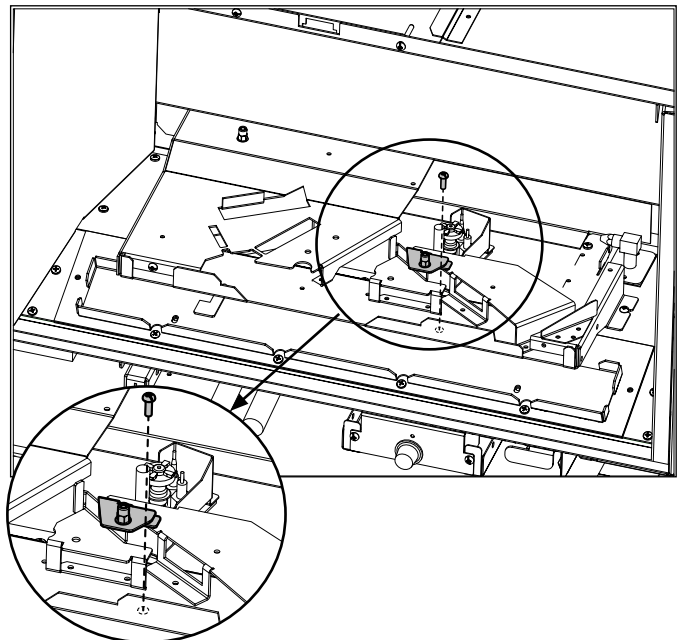

8. Re-install the burner and pilot shield.

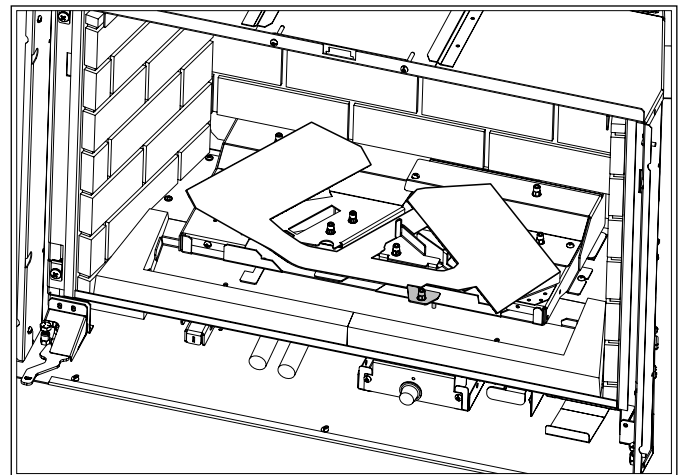

# installation

9. Fill the glass tray with 3/4" glass until it is full.

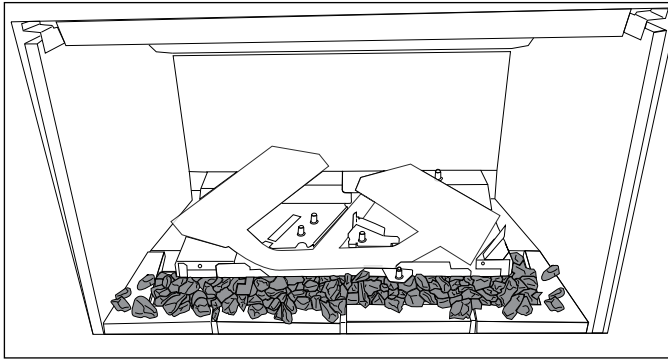

10. Fill the outside of the Burner Tray and around the Glass Tray with Black Embers as shown. Do not fill the sides of the firebox past the Burner Tray.

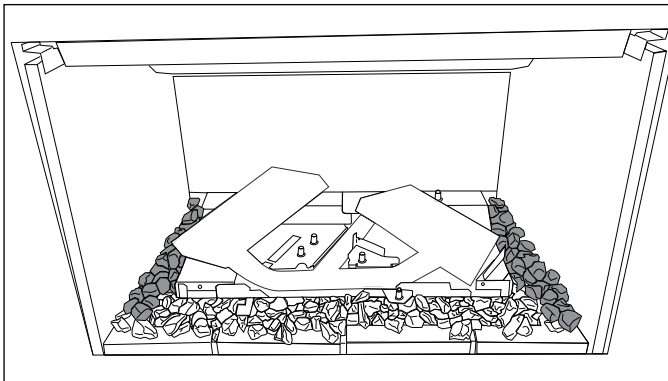

11. Add more 3/4" glass and black embers and fill the rest of the firebox. Mixing the black embers and glass will create a more realistic look.

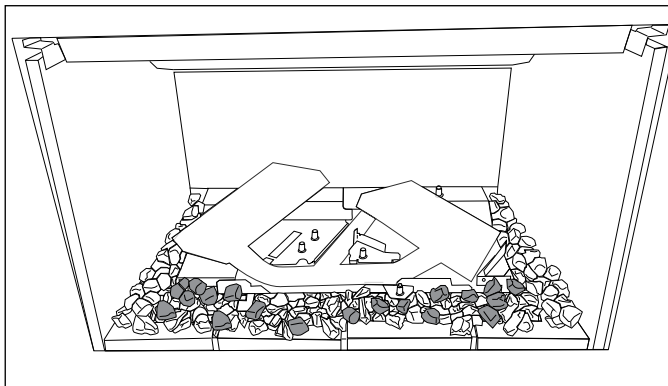

**NOTE** Not all media is used in the install, there will be leftover glass and embers.

12. Carefully lay Log 1 on the two pins behind the burner. Make sure the left part of the log does not hit the left portion of the burner.

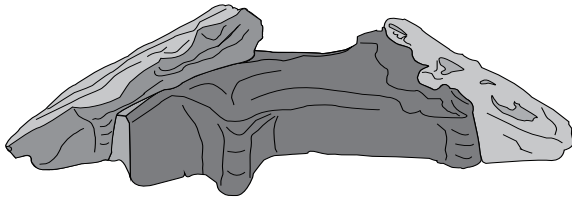

*Log 1*

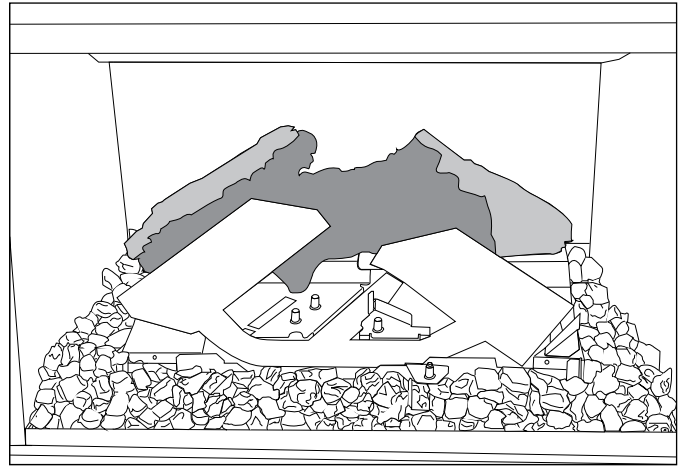

13. Place Log 2 behind the left portion of the burner, resting its right side in the notched area on Log 1. Rotate the front of Log 2 onto the metal flange and ensure it is resting directly on the tray, with no embers underneath.

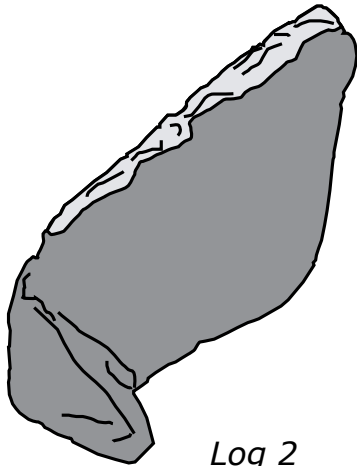

*Log 2*

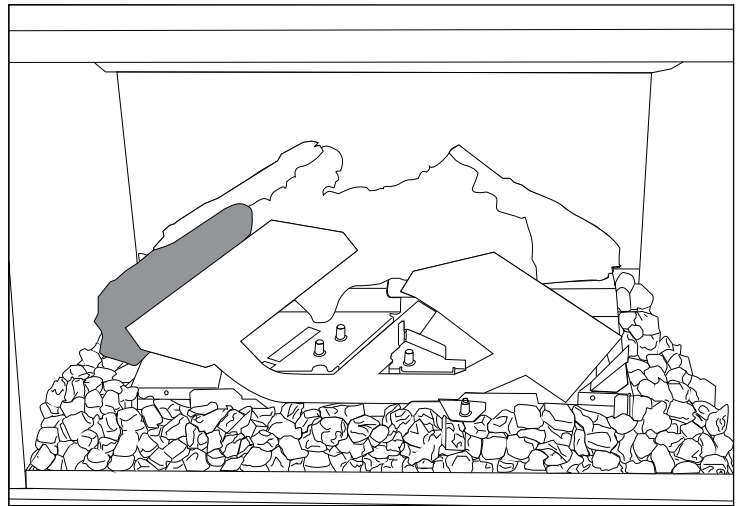

14. Place Log 3 on the pin and rotate it until it touches the tab shown below. Ensure that Log 3 is resting directly on the tray with no embers underneath.

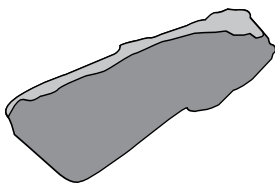

*Log 3*

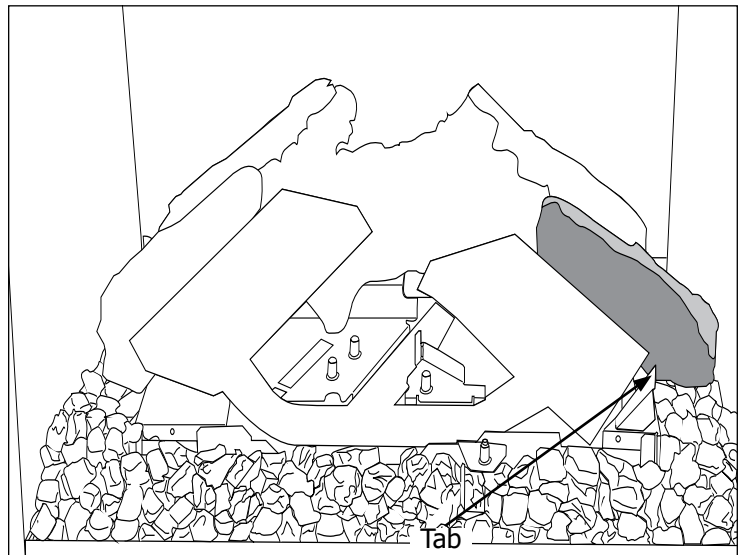

# installation

15. Place Log 4 on the two pins under the left burner.

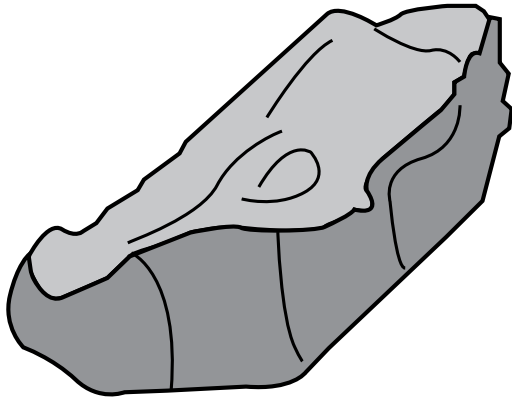

*Log 4*

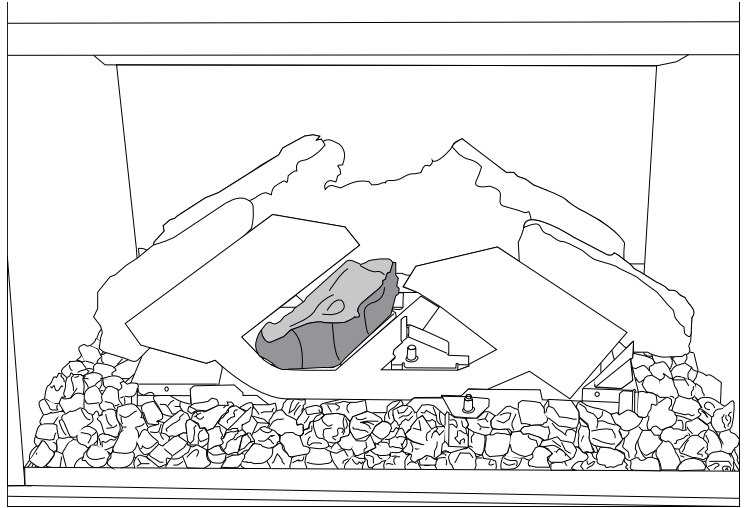

16. Place Log 5 on the pin under the right burner.

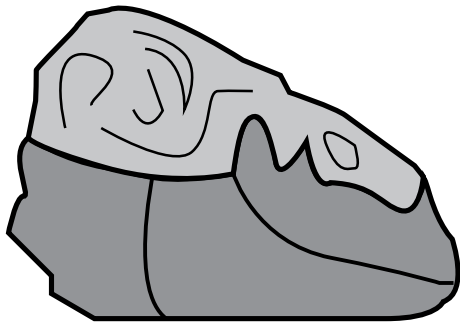

*Log 5*

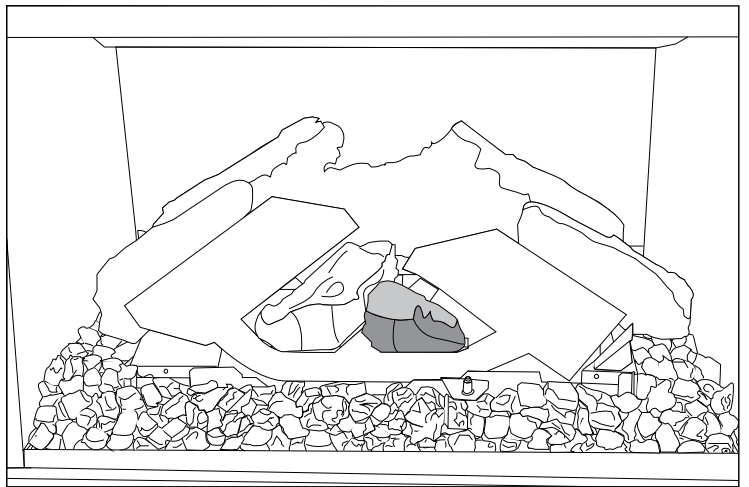

17. Place Log 6 on the right end of the burner. The log rests on the burner.

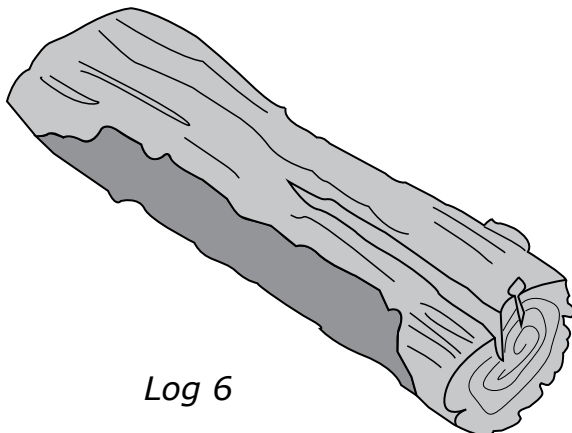

*Log 6*

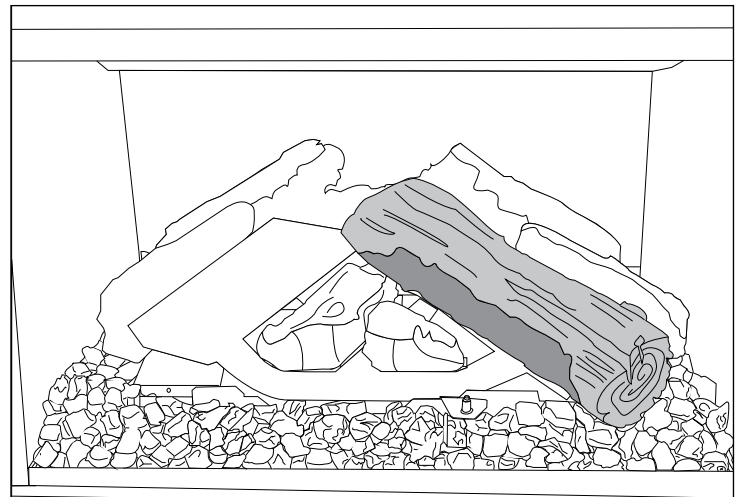



18. Place Log 7 on the left of the burner. The log rests on the burner.

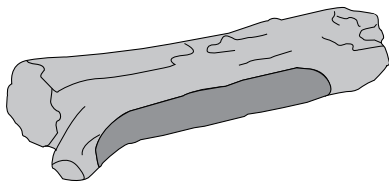

*Log 7*

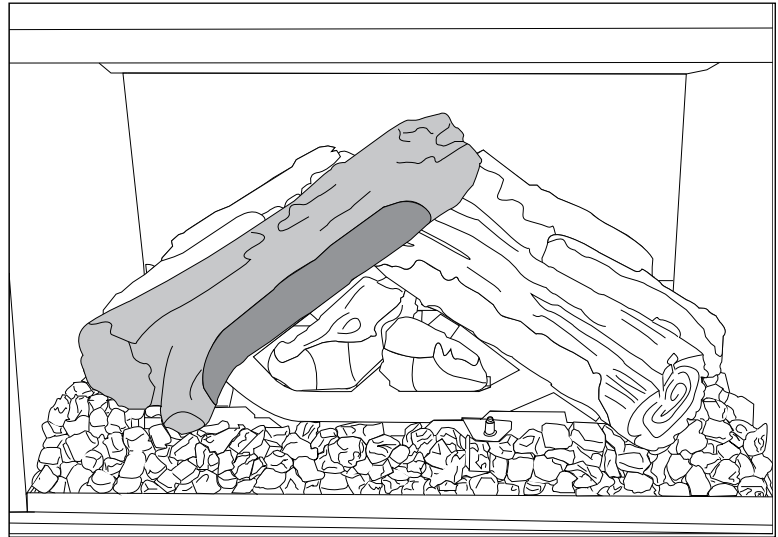

19. Place Log 8 on the pin on the front log mount. The other end will rest on the ember media.

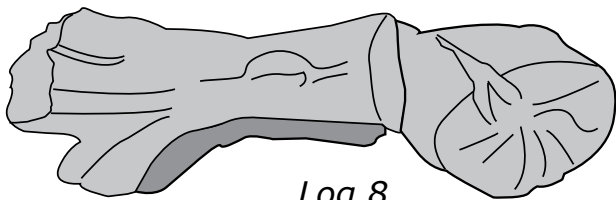

*Log 8*

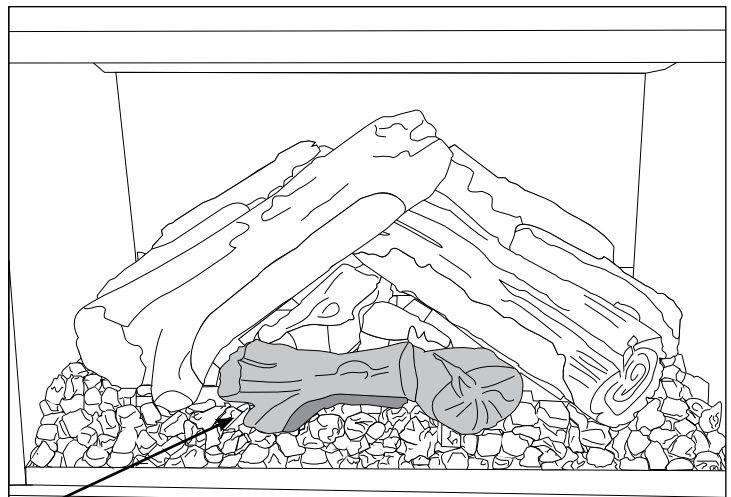

NOTE:  
IGNORE TAB UNDER BURNER TRAY, THIS IS  
UTILIZED ON THE OAK/BIRCH LOG SET. COVER  
TAB WITH EMBER OR GLASS MEDIA.

installation

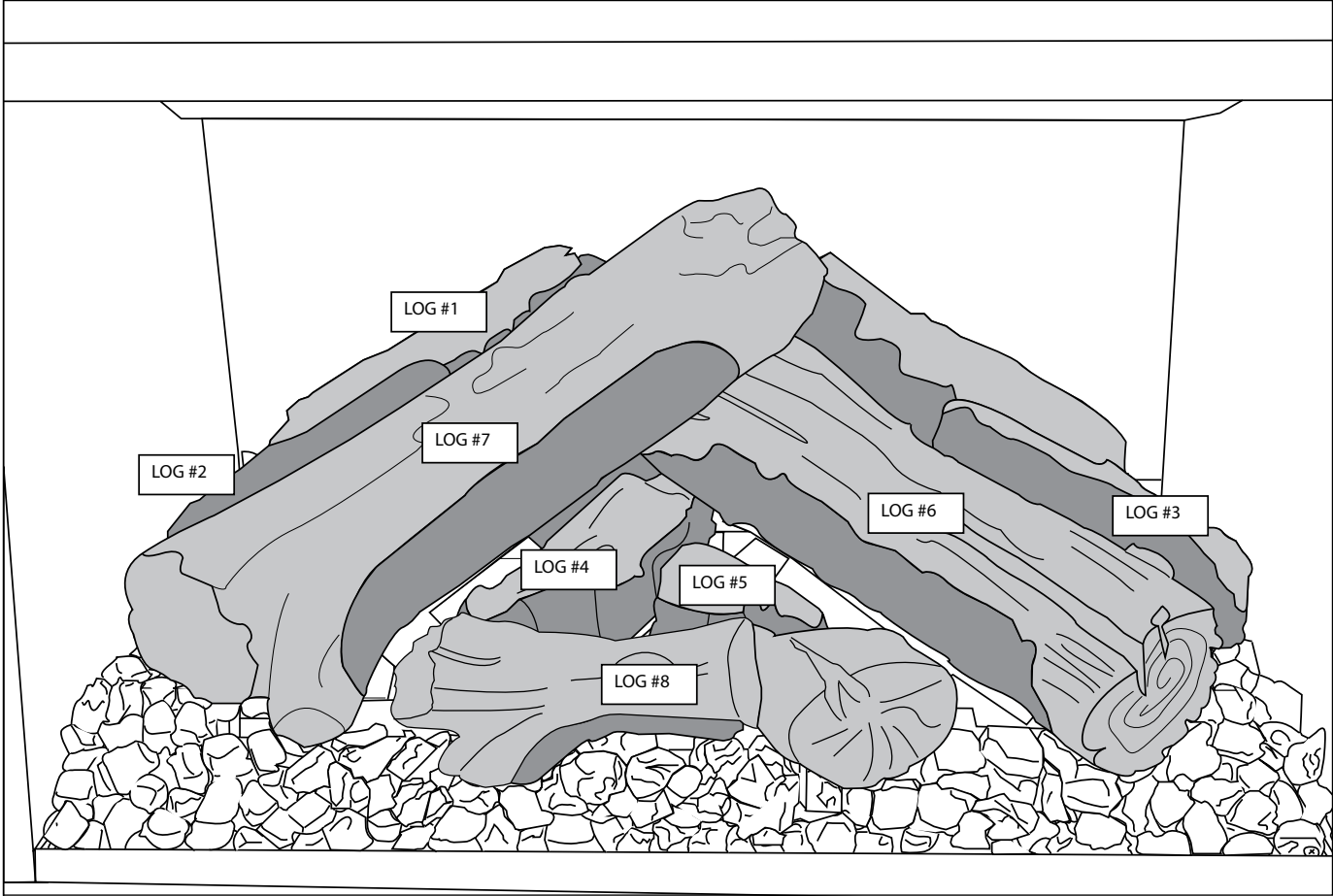

*Final Placement*

## Screen Removal

1. Gently lift screen assembly out.

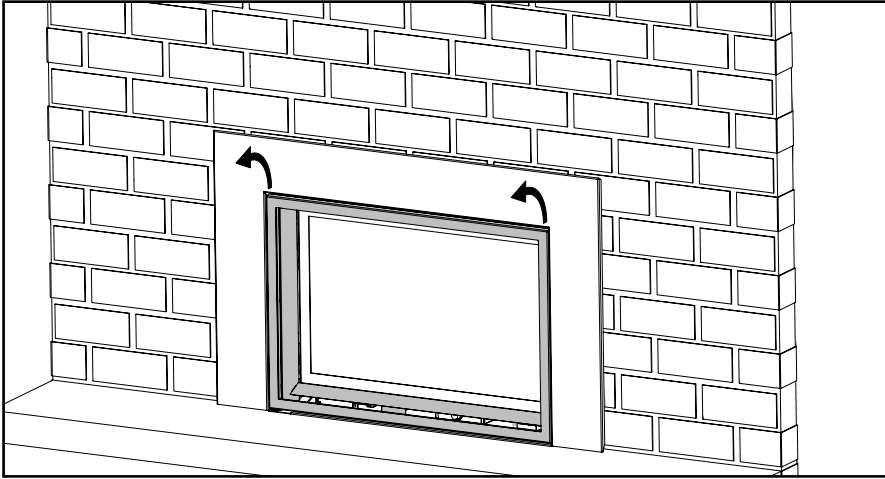

2. Place screen assembly where it will not be scratched or broken.

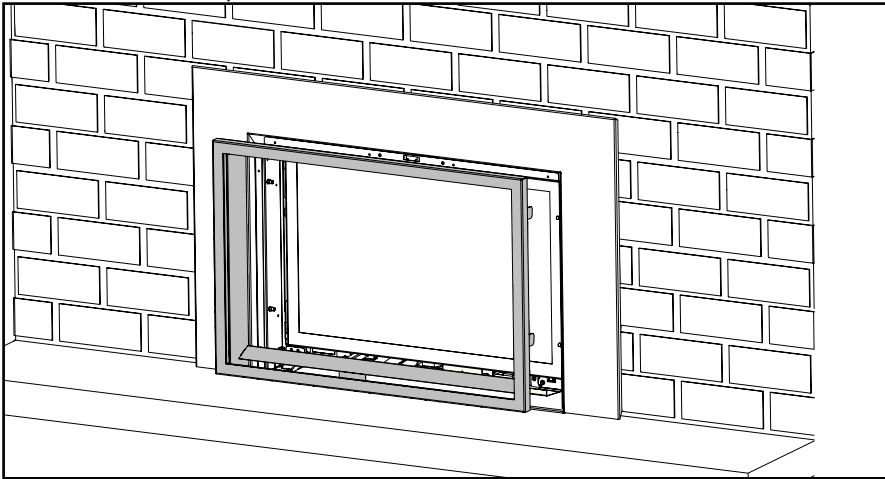

# installation

## Glass Door Removal

1. Locate and remove the four forward-facing Phillips head screws in the locations shown.

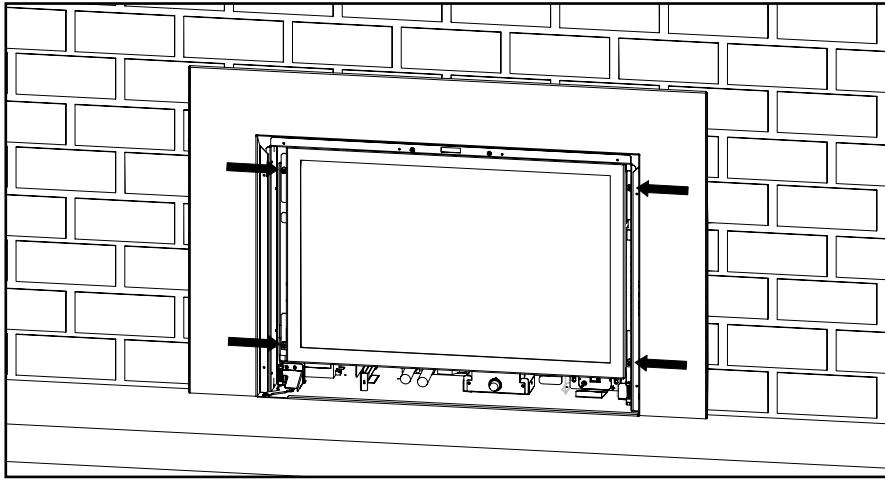

2. Lift glass door up and out.

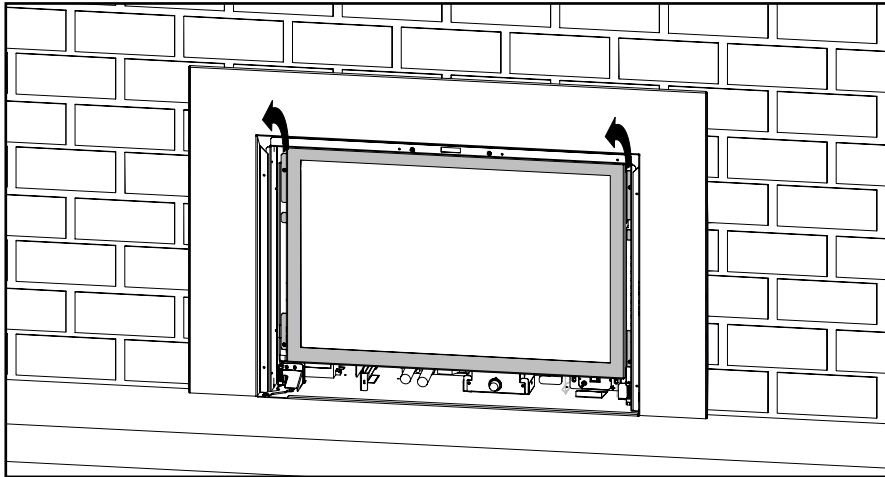

3. Place glass door in a safe place where it will not be scratched or broken.

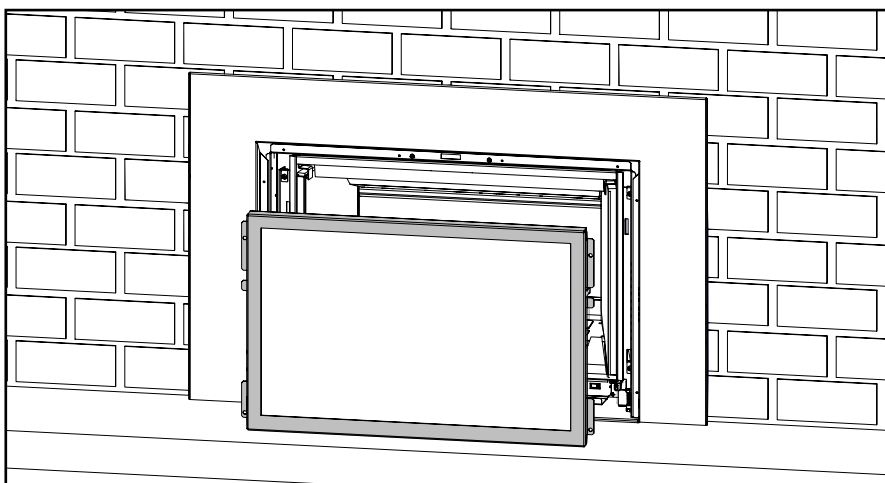

## Faceplate/Finishing Trim Installation

**These instructions are for use with the following products:**

Part #	Description
311-910	Faceplate Regular 3-Sided Black
311-912	Faceplate Flush 3-Side Black
311-913	Faceplate Flush 4-Sided Black
311-914	Finishing Trim 3-Sided Black
311-915	Finishing Trim 4-Sided Black

3. Fasten the four screws on both sides to attach the faceplate/finishing trim.

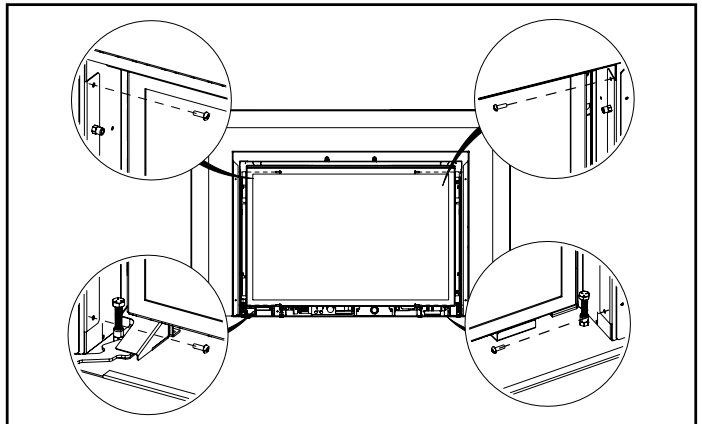

1. Remove the four screws supplied with the faceplate/finishing trim.

2. Position the faceplate/finishing trim. If installing a premium surround refer to "Premium Surround Installation".

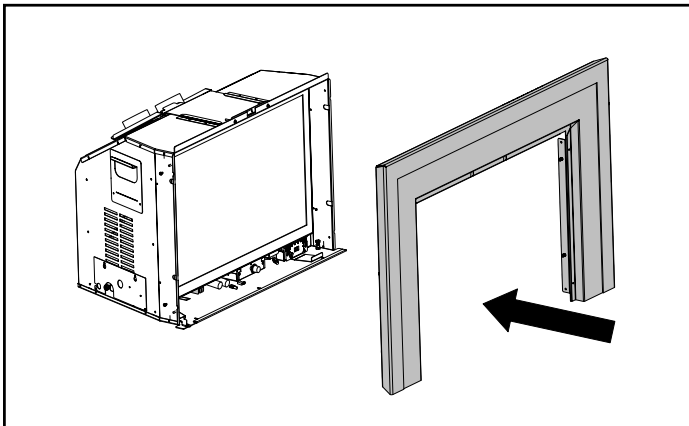

4. Install the compact screen.

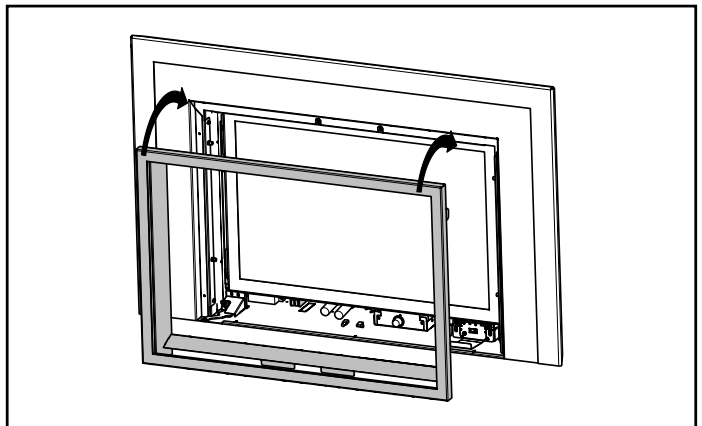

# installation

## Backing Plate Installation

These instructions are for use with the following products:

Part #	Description
311-936	Backing Plate 3-Sided Oversized Black
311-937	Backing Plate Custom 3-Sided
311-938	Backing Plate Custom 4-Sided

1. Attach the brackets on both sides using the four screws provided, ensuring they sit at the front of the slots.

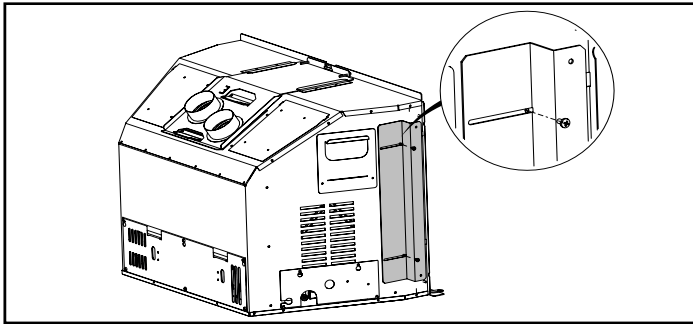

2. Position the backing plate.

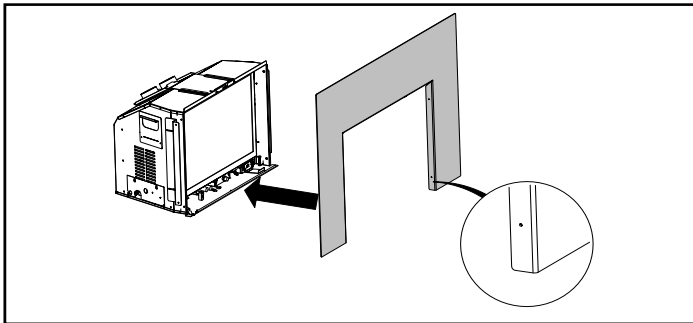

3. Fasten four screws on both sides to attach the backing plate.

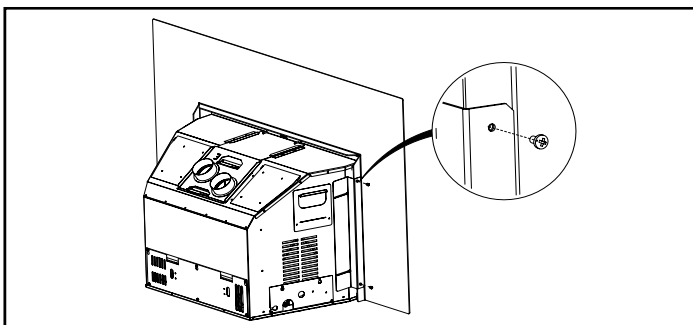

4. Remove the four screws at the front of the unit.

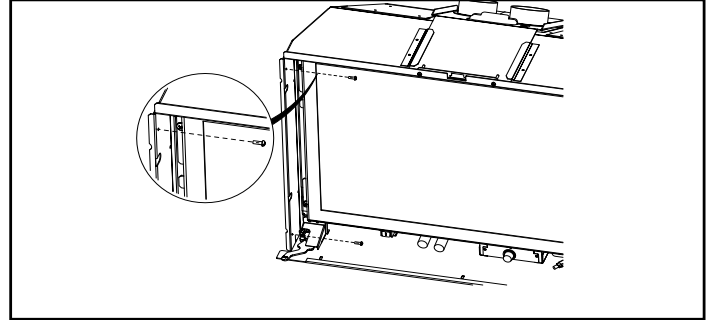

5. Position the faceplate. If installing a premium surround, refer to "Premium Surround Installation".

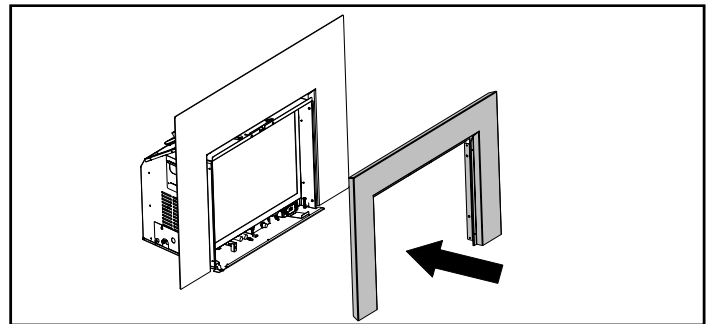

6. Fasten the four screws on both sides to attach the faceplate.

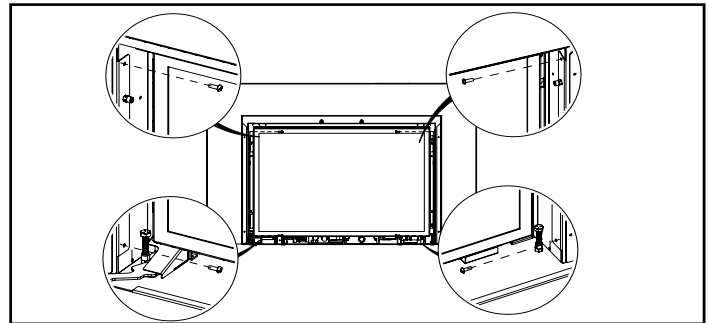

7. Slightly loosen the screws shown below on both sides.

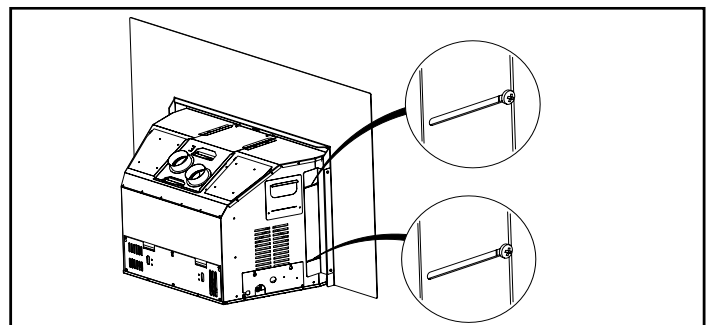

8. Pull the backing plate as far forward as possible against the faceplate, then retighten the screws on both sides.

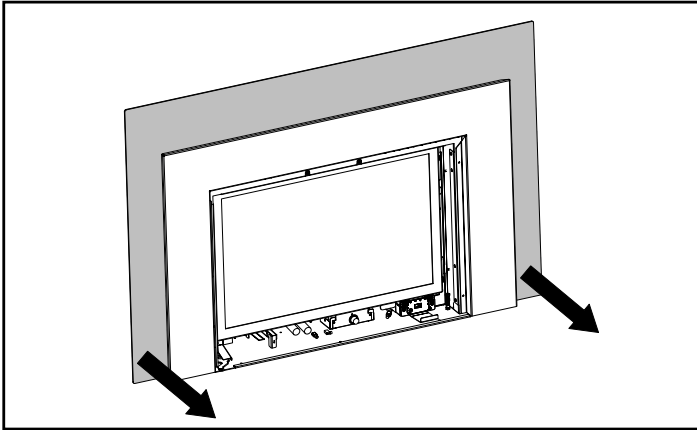

9. Install the compact screen.

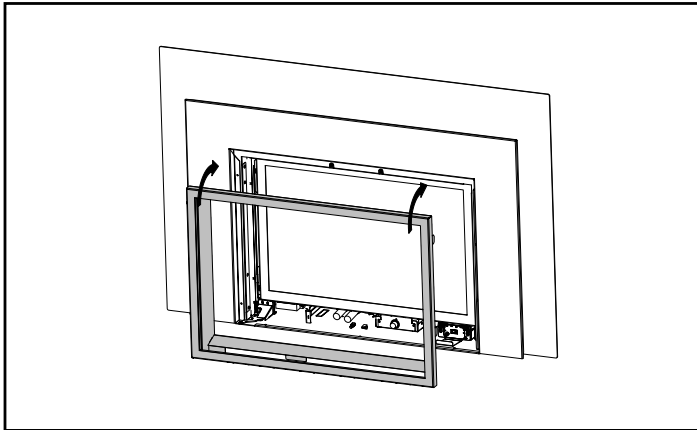

# installation

## Mantel Deflector Installation

1. Fasten the two screws provided from the back to attach the mantel deflector.

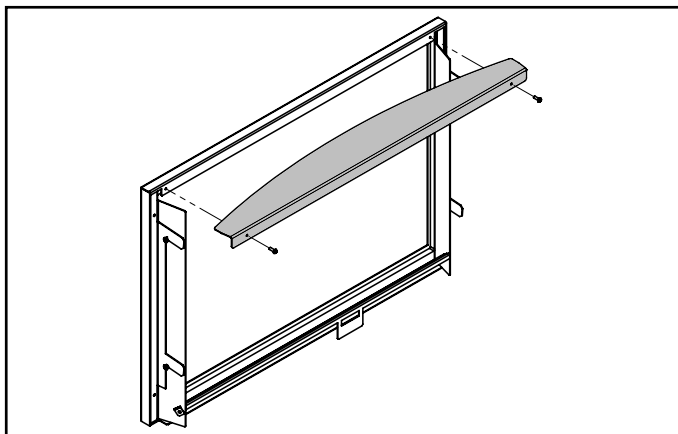

3. Install the compact screen.

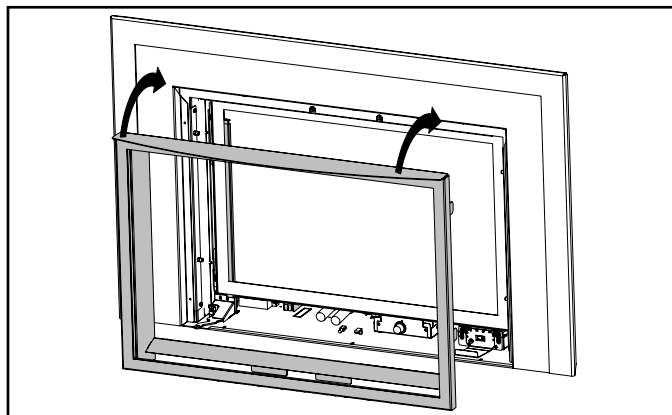

2. Mantel deflector installed.

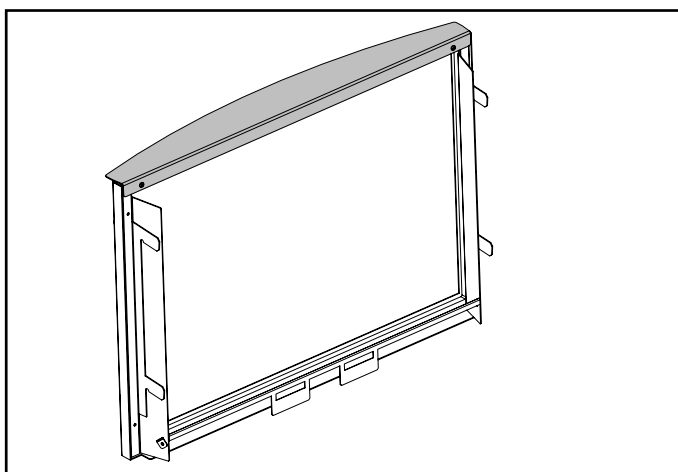



## Premium Faceplate Surround Installation

These instructions are for use with the following products:

PART #	Description
311-920	Faceplate Surround Black
311-921	Faceplate Surround Grey
311-922	Faceplate Surround White
311-923	Faceplate Surround Sunset Bronze
311-924	Faceplate Surround Brushed Nickel

1. Gently slide the faceplate surround on from the top.

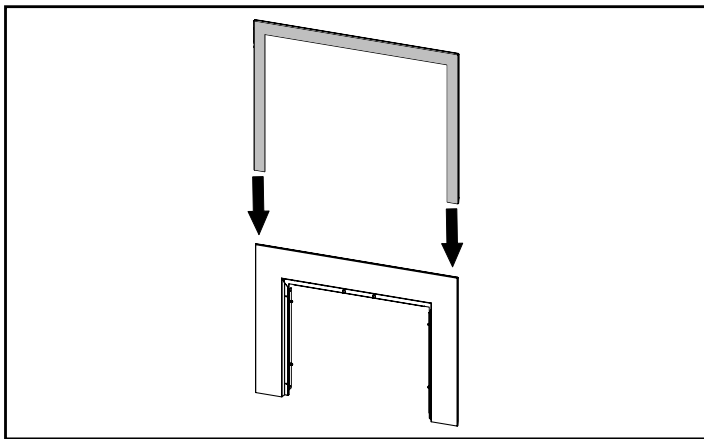

2. Faceplate surround installed.

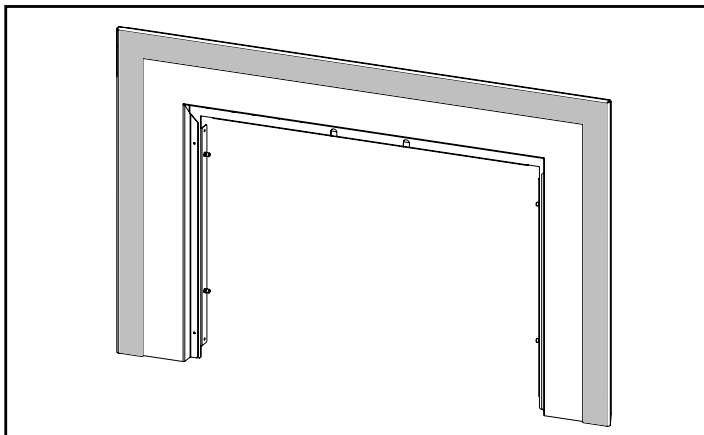

3. Lift the faceplate and faceplate surround up from the top edge and refer to "Faceplate / Finishing Trim Installation".

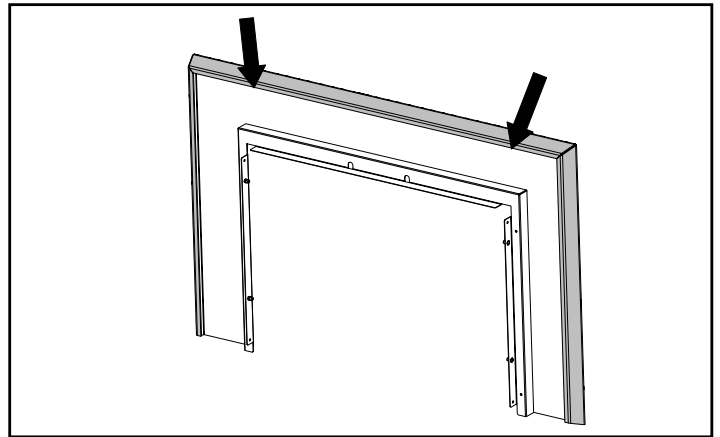

# installation

## Traditional Faceplate Surround Installation (Part #311-927, 311-928)

These instructions are for use with the following products:

PART #	Description
311-927	Gi29 Traditional Surround Black
311-928	Gi29 Traditional Surround Brushed Antique Copper

1. Slide the corner clips in on either end.

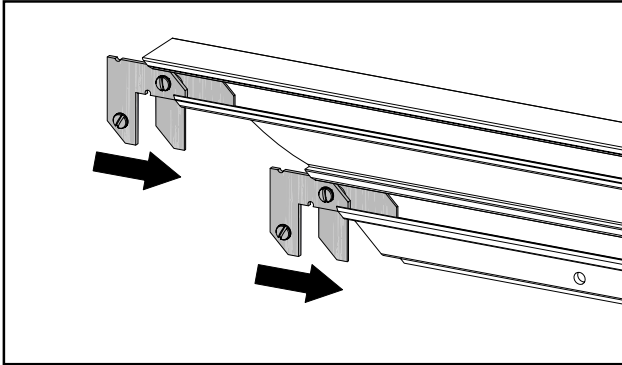

2. Tighten the top screws (x4).

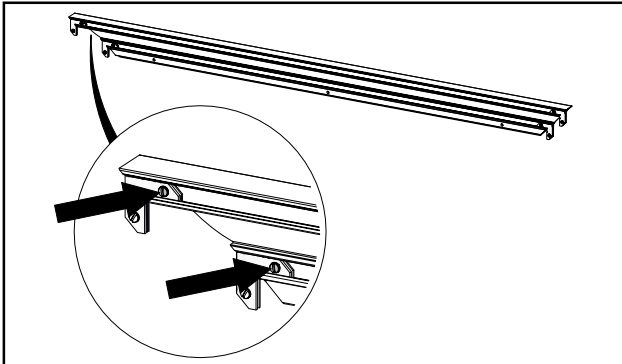

3. Slide the side pieces on.

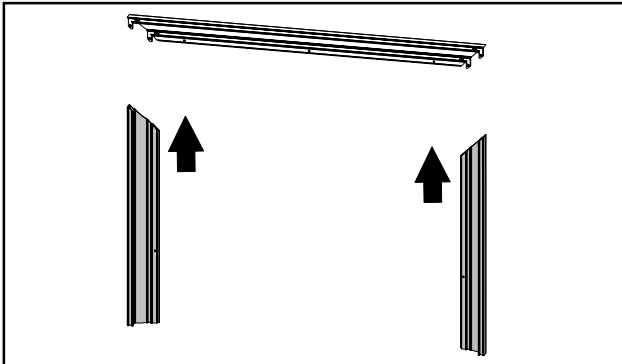

4. Tighten the bottom screws (x4).

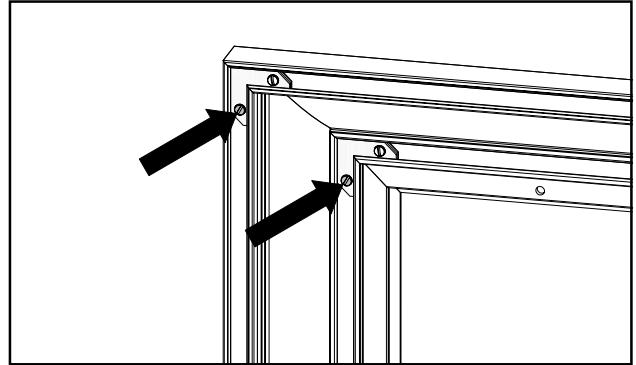

5. Gently slide the traditional surround on from the top.

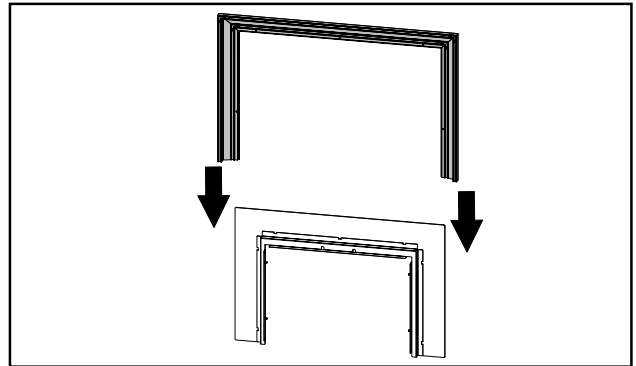

6. Insert and tighten the rear screws (x5). Traditional surround installed.

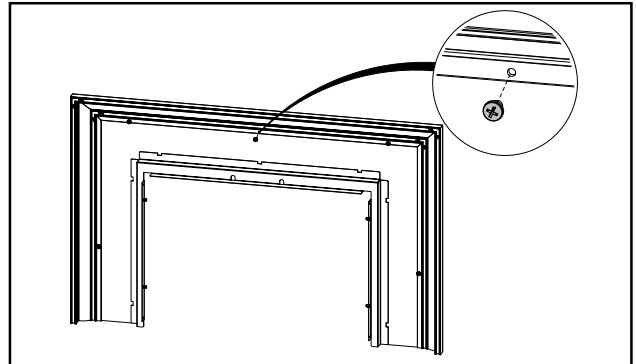

7. Lift the faceplate and traditional surround up from here and refer to "Faceplate / Finishing Trim Installation".

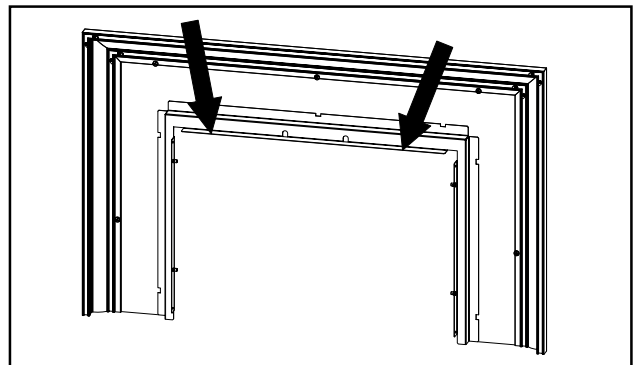

## Hearth Trim Installation - Trimming to Height

1. Remove the lower section of hearth trim by pulling evenly from both sides.

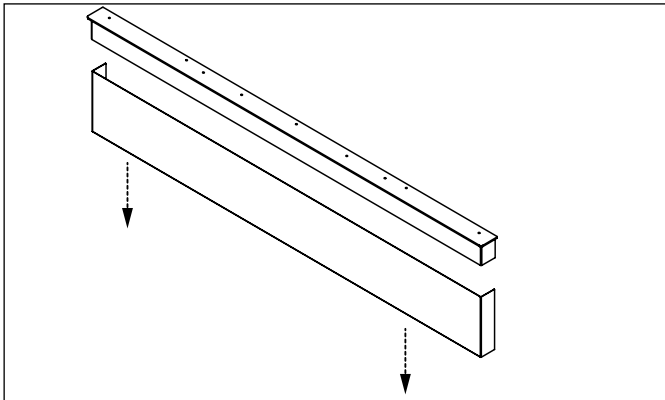

2. If using a grinder (recommended): trim the lower section to height referring to the installation table for the amount to remove.

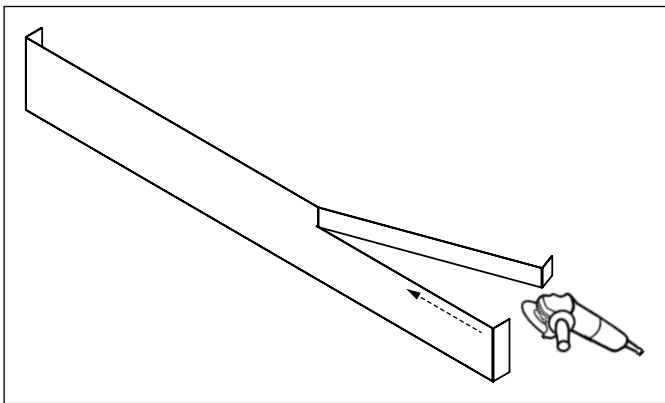

- 2a. If using snips:

- Cut horizontally, referring to the installation table for the amount to remove.
- Cut vertically along the corner to meet the previous cut.
- Cut horizontally across the front face.
- Repeat the process on the opposite side.

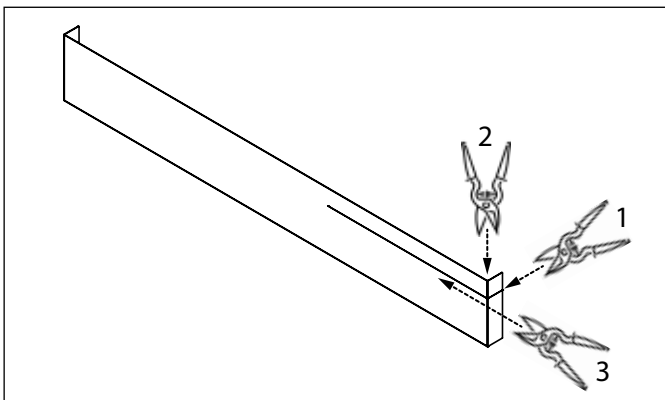

3. Slide the lower section back into the clips on the rear of the upper section.

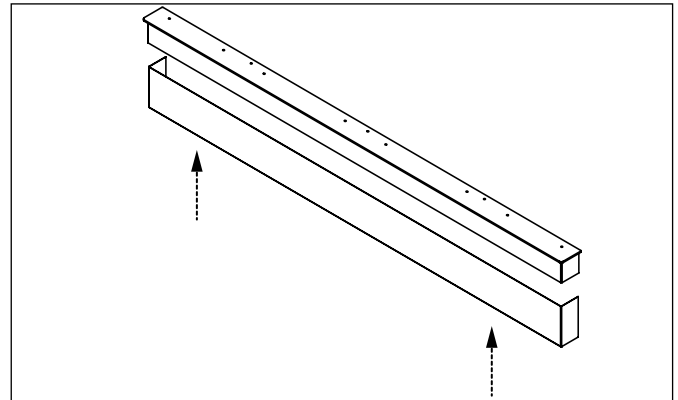

Installation Table	
Required install height	Height to cut off lower section
6" (Max)	None
5 1/2"	1/2"
5"	1"
4 1/2"	1 1/2"
4"	2"
3 1/2"	2 1/2"
3"	3"
2 1/2"	3 1/2"
2" (Min)	4"

# installation

## Hearth Trim Installation - Mounting Hearth Trim

1. Loosely attach the hearth trim using the slots in the unit's base and the included screw.

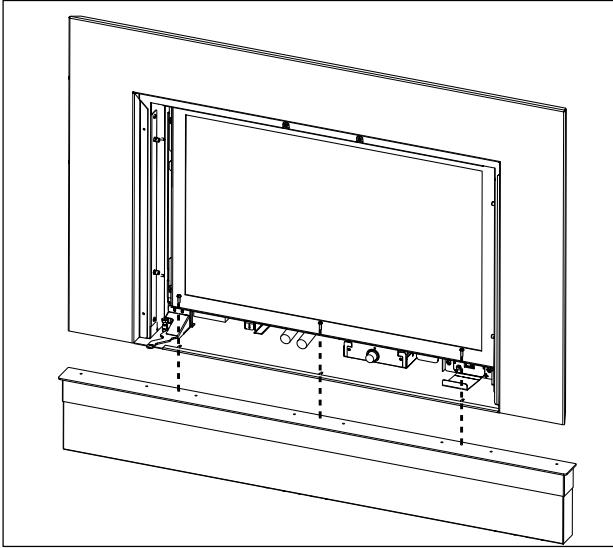

2b. With premium surround: slide the hearth trim as far back as possible (careful not to scratch it) and tighten the screws.

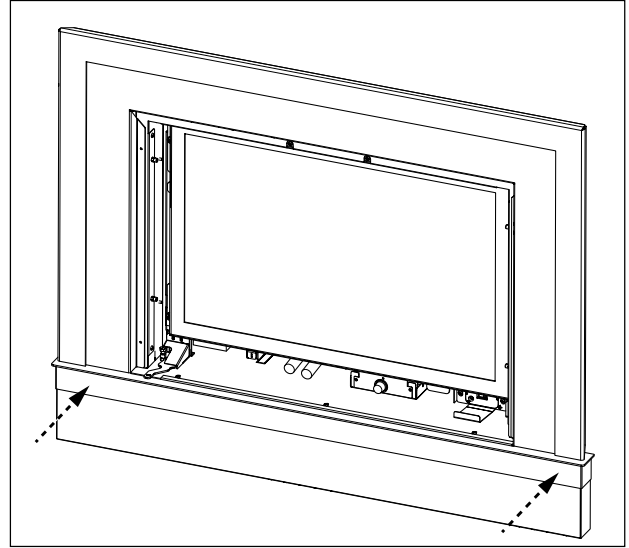

2a. Without premium surround: slide the hearth trim as far forward as possible (careful not to scratch it) and tighten the screws.

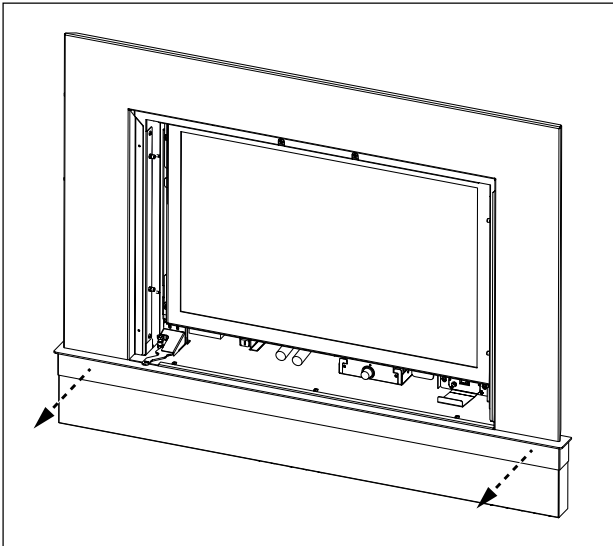

## Optional Wall Thermostat

A wall thermostat may be installed if desired; follow the wiring diagram below. FPI offers an optional programmable thermostat, but any 250-750 millivolt rated non-anticipator type thermostat that is CSA, ULC, or UL approved may be used.

## Thermostat Wire Table

Recommended Maximum Lead Length (Two-Wire) When Using Wall Thermostat (CP-2 System)	
Wire Size	Max. Length
14 GA.	50 ft.
16 GA.	32 ft.
18 GA.	20 ft.
20 GA.	12 ft.
22 GA.	9 ft.

**CAUTION** Do not connect the millivolt wall thermostat wires to the 120 V wires.

## Final Check

Before leaving this unit with the customer, the installer must ensure that the appliance is firing correctly. This includes:

1. Locking the appliance to ensure the correct firing rate (noted on the label) at 15 minutes.
2. If required, adjusting the primary air to ensure that the flame does not carbon. Allow the unit to burn for 15 min. to stabilize.
3. Checking for proper draft.

**CAUTION** Any alteration to the product that causes sooting or carboning resulting in damage to the exterior fascia is not the responsibility of the manufacturer.

## Supplied Remote Control

Use the FPI remote control kit supplied with this unit. Use of other systems may void your warranty.

The remote control kit comes with a handheld transmitter and a remote receiver.

Install three AAA alkaline batteries in the transmitter and four AA alkaline batteries in the receiver. Switch the remote receiver to "remote" mode - it is now ready for operation.

**NOTE** The remote receiver will be located on the lower right side of the appliance. See below.

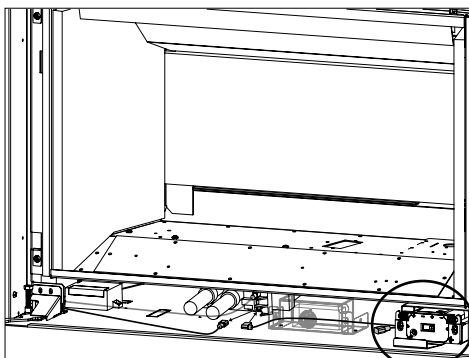

Remote receiver location

# installation

## Wiring Diagram

This heater does not require a 120 V A.C. supply for operation. In case of a power failure, the burner switch and the remote control/thermostat will continue to operate. However, a 120 V A.C. power supply is needed for the fan/blower operation.

**CAUTION** Ensure that the wires do not touch any hot surfaces and are away from sharp edges.

## S.I.T. Valve

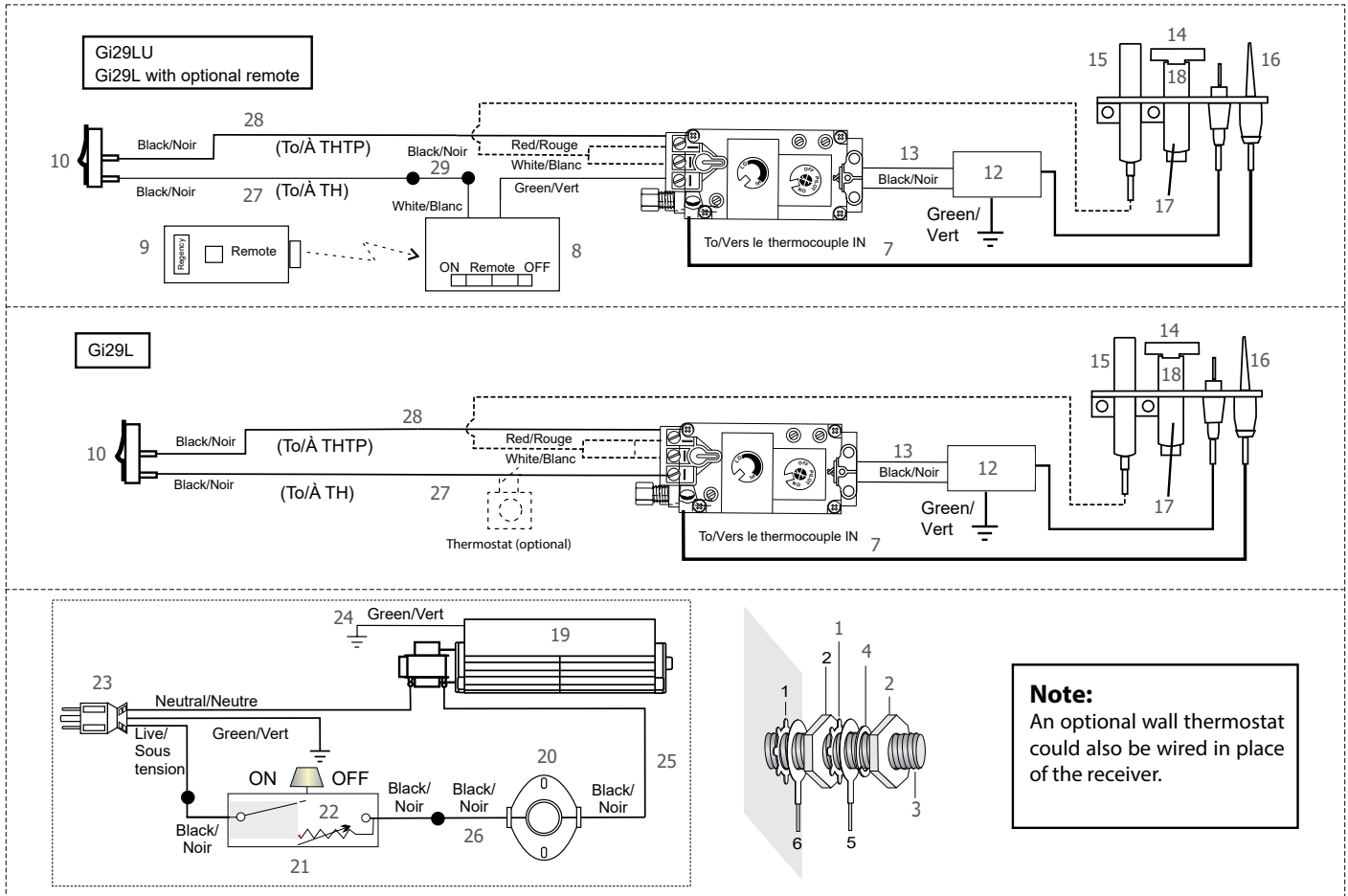

ITEM	PART #	DESCRIPTION
1	904-153	Star Lock Washer
2	904-330	8-32 Hex Nut
3	904-612	8-32 x 1/2" Ground Lug
4	904-169	#10 Split Lock Washer
5	910-692	Green Ground Wire
6	N/A	Power Cord Ground Wire
7	910-478	Novasit Gas valve NG/LP
8	911-338/P	Remote Transmitter
9	910-592-OFT	Remote Receiver
10	311-526	ON/OFF switch Assembly
11	911-308	Remote Receiver Wire (Each)

ITEM	PART #	DESCRIPTION
12	910-073	DC Spark Generator Battery Box
13	910-074	DC Spark Generator Switch c/w Wires
14	910-038/P	Pilot Assembly - NG
14	910-039/P	Pilot Assembly - LP
15	910-341	Thermopile
16	910-386	Thermocouple
17	910-030	Spark Electrode
18	910-096	3 Way Pilot Hood
19	911-071/P	Blower Motor
20	W241050	Fan Thermodisc

ITEM	PART #	DESCRIPTION
21	910-330	Fan Speed Controller
22	904-586	Fan Speed Control Knob
23	911-096	120 Volt Power Cord
24	910-692	Green Ground Wire
25	910-811	Black Wire
26	910-896	Black Wire
27	910-811	ON/OFF Burner Switch Wire
28	910-818	ON/OFF Burner Switch Wire
29	911-417	Black Jumper Wire
N/S	911-164	Remote Wiring Harness

## Operating Instructions

Before operating this appliance, proceed through the following checklist.

1. Read and understand these instructions before operating this appliance.
2. Check to see that all wiring is correct and enclosed to prevent possible shock.
3. Check to ensure there are no gas leaks.
4. Make sure the glass door is in place. Never operate the appliance with the door glass removed.
5. Verify that the venting and the cap is unobstructed.
6. Verify the placement of logs and other decorative media. If the pilot cannot be seen when lighting the unit, the logs/media are incorrectly positioned.
7. DO NOT turn the unit off and on without first waiting 60 seconds.
8. When lighting the appliance, the inside of the glass may fog. This will burn off after a few minutes of operation.

**DO NOT BURN THE APPLIANCE WITH THE GLASS DOOR REMOVED.**

## Lighting Procedure

**IMPORTANT** To ignite or reignite the pilot, you must first remove the glass door.

1. Push the gas control knob in slightly and turn it to the "PILOT" position.
2. Push the control knob in all the way and hold it until the pilot lights. Continue to hold the control knob for about 20 seconds after the pilot is lit. Release the knob.

### If the Pilot Does Not Light

- 2a. Push the gas control knob in slightly and turn it clockwise to the OFF position. The knob cannot be turned from PILOT to OFF unless the knob is pushed in slightly. Do not force.
- 2b. Wait five (5) minutes to clear out any gas. If you still smell gas, STOP! Follow step B in the safety information on the label above. If you don't smell gas, repeat steps 1 and 2.
3. Push the gas control knob in slightly and turn it to the ON position.
4. Install the glass barrier.
5. Switch the On/Off lever to the ON position.

## Shutdown Procedure

1. Switch On/Off lever to the OFF position.
2. Allow the unit to cool then remove the glass barrier.
3. Push in the gas control knob slightly and turn clockwise to "OFF". Do not force.
4. Turn off all electric power to the appliance if service is to be performed. The pilot must be shut off during prolonged periods of disuse, to conserve fuel.

## First Fire

The first fire in your stove is part of the paint curing process. To ensure that the paint is properly cured, it is recommended that you burn your fireplace for at least four (4) hours the first time you use it, with the fan on. The unit will release an odour caused by the curing of the paint and the burning of any oils remaining from manufacturing. Smoke detectors in the house may go off at this time. Open a few windows to ventilate the room for a couple of hours.

The glass panel may require cleaning after the unit has cooled down.

**DO NOT ATTEMPT TO CLEAN THE GLASS WHILE IT IS HOT.**

**NOTE** When the glass is cold and the appliance is lit, condensation may fog the glass. This is normal and will disappear in a few minutes as the glass heats up.

**DO NOT BURN THE APPLIANCE WITH-OUT THE GLASS FRONT IN PLACE.**

During the first few fires, a white film may develop on the glass front as part of the curing process. The glass should be cleaned or the film will bake on and become very difficult to remove. Use a non-abrasive cleaner and NEVER clean the glass while it is hot.

## Automatic Convection Fan Operation

The fan operates automatically once turned on (use the knob located behind the screen at the bottom of the unit). Adjust the fan speed with the knob. The fan will turn on as the stove comes to operating temperature. After the unit is turned off and cooled to below a useful heat output range, the fan will shut off automatically.

## On/Off Switch

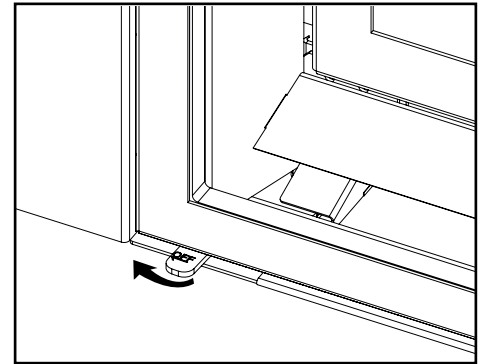

With the pilot on, turn the switch to the right to turn the burner on. Moving the switch to the left will turn the burner off.

**NOTE** This ON/OFF switch will be located on the lower left-hand side of the appliance as shown above.

## On/Off/Pilot Extension Knob Hi/Low Extension Knob Fan Control Knob

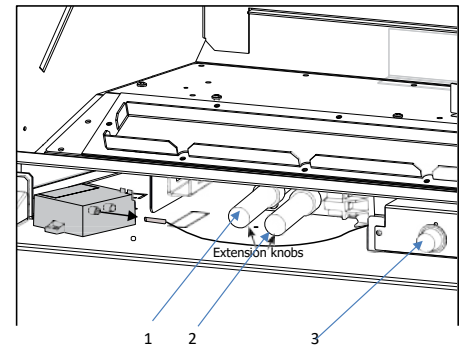

1. ON/OFF/Extension Knob - Lights the pilot. See specific lighting instructions on how to light pilot.
2. Hi/Low extension knob - Increases/decreases flame height by turning extension knob clockwise/ counterclockwise.
3. Fan Control Knob - Increases/decreases fan speed by turning control knob clockwise/counterclockwise. This will also shut fan OFF.

# owner's information

## Proflame I Remote Control Operating Instructions

**IMPORTANT:**The Proflame Transmitter 1 is an integrated part of the Proflame 1 System, which consists of these elements:

- Proflame 1 Transmitter, to be used in conjunction with:
- Integrated Fireplaces Control (Proflame 1 DFG)

The Proflame 1 Transmitter provides for controlling the following hearth appliance functions:

1. Main Burner On/Off
2. Main Burner flame modulation (6 levels)\*\*
3. Thermostat and Smart thermostat functions
4. Accent light modulation (6 levels)\*\*
5. Comfort Fan speed modulation (6 levels)\*\*

\*\* This feature is not available on all models.

The Proflame Transmitter uses a streamline design with a simple button layout and informative LCD display (Fig. 1). A Mode Key is provided to index between the features and a Thermostat Key is used to turn on/off or index through Thermostat functions (Fig. 1 & 2). Additionally, a Key Lock feature is provided (Fig. 22).



Figure 1: Proflame Transmitter

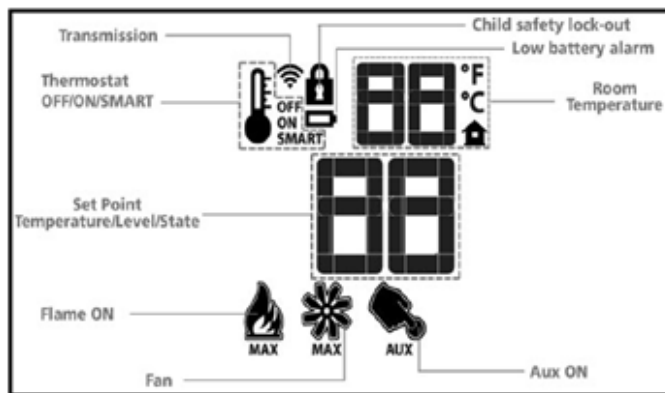

Figure 2: Transmitter LCD Display

**Note:** May not be exactly as shown as hand-held may be silver or black.

TECHNICAL DATA REMOTE CONTROL	
Supply Voltage	4.5V (three 1.5V AAA batteries)
Ambient temperature ratings	0 - 50°C (32 - 122°F)
Radio Frequency	315 MHZ

**WARNING: THE TRANSMITTER AND RECEIVER ARE RADIO FREQUENCY DEVICES. PLACING THE RECEIVER IN OR NEAR METAL MAY SEVERELY REDUCE THE SIGNAL RANGE.**

### ATTENTION!

- Turn "OFF" the main gas supply of the appliance during installation or maintenance of the Receiver device.
- Turn "OFF" main gas supply to the appliance prior to removing or reinserting the batteries.
- In case of remote control malfunction, turn off the IFC device using the "ON/OFF" main switch.
- For installation / maintenance, switch off the IFC device removing main power supply plug.

### OPERATING PROCEDURE

#### Pairing the remote control to remote receiver / battery holder (if required)

Install the 4 AA batteries into the receiver battery bay. Note the polarity of the battery and insert into the battery bay as indicated on the battery cover (+/-). Place the 3 position slider switch in the "Remote" position. Press the PRG button located on the top right hand corner of receiver, see the receiver instruction(\*). The Receiver will "beep" three (3) times to indicate that it is ready to synchronize with a Transmitter. Install the 3 AAA type batteries in the Transmitter battery bay, located on the base of the Transmitter (Fig. 3). With the batteries already installed in the Transmitter, push the On button. The Receiver will "beep" four times to indicate the Transmitter's command is accepted and sets to the particular code of that Transmitter. The system is now initialized.

(\*). The receiver may be independent or integral to the IFC hearth appliance control module. The receiver instruction may not be independent when part of the IFC.



Figure 3: Battery Compartment

**Note:** Only use regular alkaline batteries. Do not use rechargeable or lithium batteries.



### Temperature indication Display

With the system in the "OFF" position, press the Thermostat Key and the Mode Key at the same time. Look at the LCD screen on the transmitter to verify that a C or F is visible to the right of the room temperature display (Figures 4 & 5).

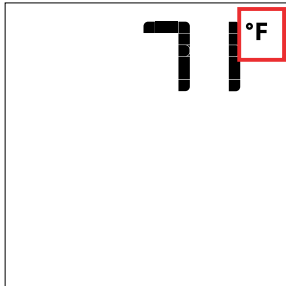

Figure 4: Remote Control display in Fahrenheit.

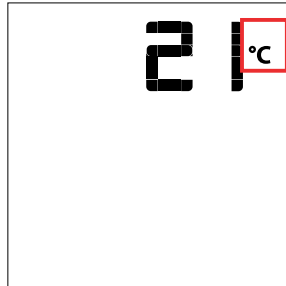

Figure 5: Remote Control display in Celsius.

### Turn on the Appliance

With the system OFF, press the ON/OFF Key on the Transmitter. The Transmitter display will show some other active Icons on the screen. At the same time the Receiver will activate the appliance. A single "beep" from the Receiver will confirm reception of the command.

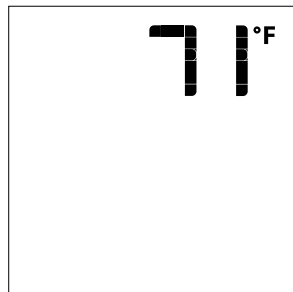

Figure 6: Remote Control display

### Turn off the Appliance

With the system ON, press the ON/OFF Key on the Transmitter. The Transmitter LCD display will only show the room temperature (Fig. 6). At the same time the Receiver will turn off the appliance. A single "beep" from the Receiver confirms reception of the command.

### Room Thermostat (Transmitter Operation)

The Remote Control can operate as a room thermostat. The thermostat can be set to a desired temperature to control the comfort level in a room. To activate this function, press the Thermostat Key (Fig. 1). The LCD display on the Transmitter will change to show that the room thermostat is "ON" and the set temperature is now displayed (Fig. 9). To adjust the set temperature, press the Up or Down Arrow Keys until the desired set temperature is displayed on the LCD screen of the Transmitter.

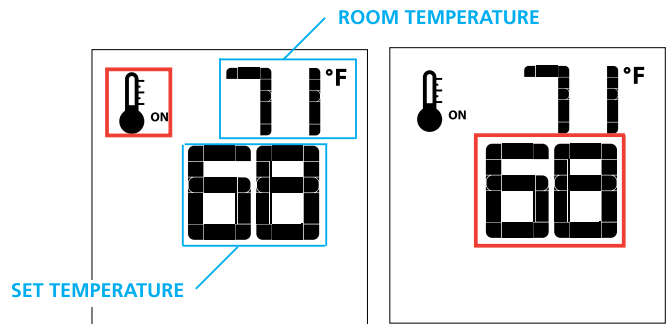

Figure 9

Figure 10

### KEY LOCK

This function will lock the keys to avoid unsupervised operation. To activate this function, press the MODE and UP Keys at the same time (fig. 18). To de-activate this function, press the MODE and UP Keys at the same time.

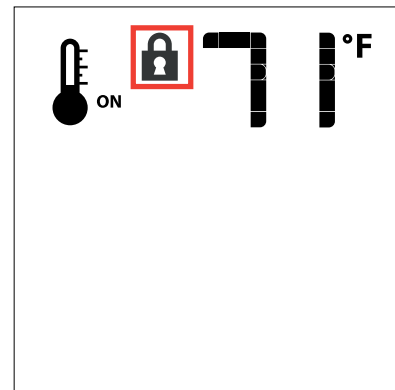

Figure 18

# owner's information

## LOW BATTERY POWER DETECTION

### Transmitter

The life span of the remote control batteries depends on various factors: quality of the batteries used, the number of ignitions of the appliance, the number of changes to the room thermostat set point, etc.

When the Transmitter batteries are low, a Battery Icon will appear on the LCD display of the Transmitter (Fig. 19) before all battery power is lost. When the batteries are replaced this Icon will disappear.

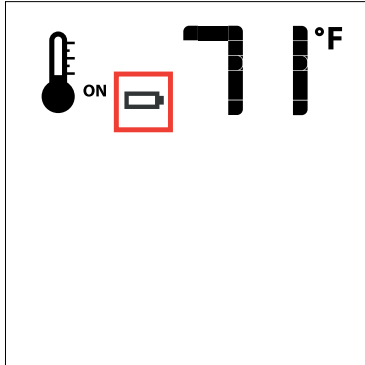

Figure 19

**ENABLE / DISABLE** functions on the Proflame I remote only.

1. Remove one battery from the remote.
2. Press and hold both the **ON/OFF** and the **MODE** button at the same time.
3. Reinstall the battery (removed in Step 1) while still holding both buttons (keep holding both buttons and once all batteries are installed then release the **MODE** button only).
4. The screen will show **CFG**.
5. Use the up or down arrow button to program out the function on the remote.

## Proflame I Remote Receiver Battery Replacement

### Remote Receiver Battery Replacement

How to replace/add the batteries on remote receiver.

Note: 4 AA batteries are mandatory in the remote receiver to operate appliance when using remote control.

The remote receiver will be located on the bottom right hand side of appliance next to the fan speed controller. The safety screen will need to be removed to gain access to this remote receiver.

#### STEP 1

Move both the left/right slides as shown below.

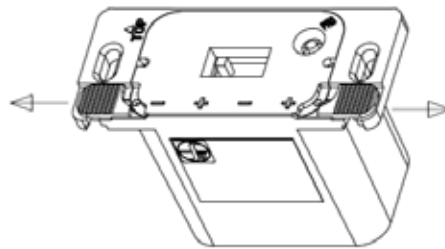

The battery compartment will be pushed out slightly, to allow to easily extract it

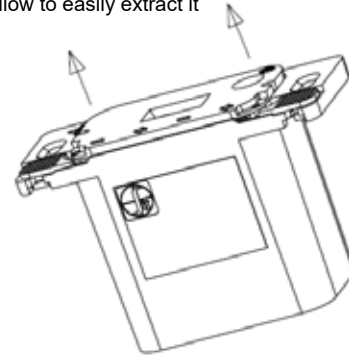

#### STEP 2

Extract the battery compartment from the remote receiver/battery holder

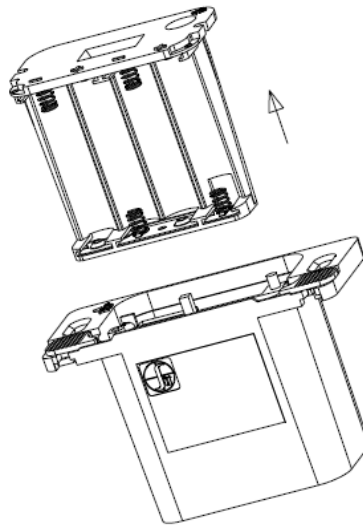

Replace 4 x AA batteries and insert the battery compartment back into remote receiver/battery holder

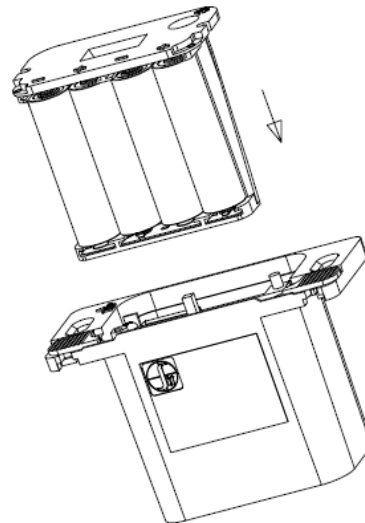

#### STEP 3

Keeping the battery compartment pressed in, close the left slide

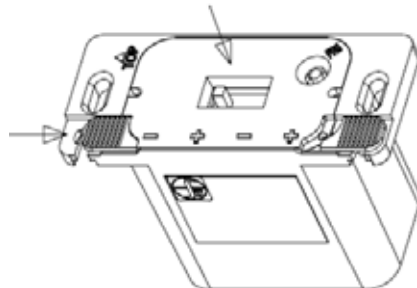

Close the right slide

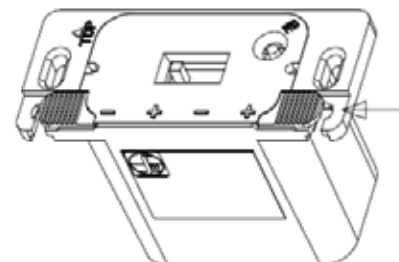

STEP 4 Reinstall wall cover plate with 2 Phillips head screws.

# operating instructions

## Operating Procedure for Remote Control

### Functionality of the Receiver

The receiver is supplied by four AA batteries (see Fig. 3). The receiver accepts commands via radio signals sent from the transmitter. The receiver sends commands by the wire harness to the multifunctional gas control. When the system is turned on, an acoustic signal (beep) is generated to indicate that the receiver is ready to receive commands from the remote control.

### Turn on the Appliance

When the ON/OFF key is pressed, the LED on the transmitter illuminates and the remote control is switched on. At the same time, the receiver connects the thermopile to the gas valve millivolt coil and the appliance main burner turns on in the high position. A single acoustic signal from the receiver confirms the reception of the command.

### Turn Off the Appliance

If the appliance and the remote control are switched on and the ON/OFF key is pressed, the remote control is turned off. At the same time, the receiver removes power from the gas valve millivolt coil and the appliance main burner turns off. A double acoustic signal from the receiver confirms the reception of the command.

### Low Battery Detection (Receiver)

The duration of the remote control batteries depends on many factors: the quality of the batteries used, the number of ignitions of the appliance, etc. If the receiver batteries are low, a triple acoustic signal is emitted by the receiver when it receives a command from the transmitter. This is an alert of a low battery condition before battery power is lost altogether. As soon as the depleted batteries are replaced, the acoustic signal from the receiver confirms the reception of the ON/OFF command from the transmitter.

### Backup Function

If the batteries of the receiver are low, the appliance can be switched on manually by moving the three-position slider switch on the receiver to the ON position.

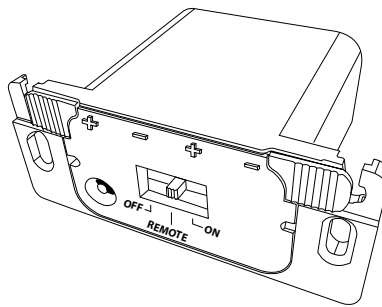

### Warnings and Cautions

WARNINGS

- **Fire hazard. Can cause severe injury or death.**
- **The receiver causes the ignition of the fireplace. The fireplace can turn on suddenly. Keep away from the burner, especially when operating the BACKUP switch.**

CAUTIONS

- **Property damage hazard. Excessive heat can cause property damage.**
- **The fireplace can stay ignited for many hours. Take care to turn off the fireplace if it is unattended by adults. Do not leave the remote control where children can reach it.**

## Normal Operating Sounds of Gas Appliances

It is possible that you will hear some sounds from your gas appliance. This is due to the various gauges and types of steel used within your appliance. Some examples are listed below. All are **normal operating sounds** and should not be considered defects in your appliance.

### Blower:

Regency® gas appliances use high-tech blowers to push heated air further into the room. It is not unusual for the fan to make a “whirring” sound when on. This sound will increase or decrease in volume depending on the speed setting of your fan speed control.

### Burner Tray:

The burner tray is positioned under the burner tube(s) and logs, and is made of a different gauge material from the rest of the firebox and body. The varying thicknesses of steel will expand and contract at slightly different rates, causing ticking and cracking sounds. You should also be aware that as there are temperature changes within the unit, these sounds will likely recur.

### Pilot Flame:

While the pilot is on, it may make a whisper sound.

### Gas Control Valve:

As the gas control valve is turned on and off, it may make a dull clicking sound. This is normal operation of a gas regulator or valve.

### Unit Body/Firebox:

Different types and thicknesses of steel will expand and contract at different rates resulting in some cracking and ticking sounds will be heard throughout the cycling process.

## Maintenance Instructions

1. Always turn off the valve before cleaning. For relighting, refer to lighting instructions. Keep the burner and control compartment clean by brushing and vacuuming at least once a year. When cleaning the logs, use a soft clean paint brush as they are fragile.
2. Clean the glass (never when the unit is hot), appliance, and door with a damp cloth. Never use an abrasive cleaner.
3. The heater is finished in porcelain or with heat-resistant paint, and should only be refinished with heat-resistant paint (not with wall paint).

Never use an abrasive cleaner.

4. Check the burner’s position and condition periodically, as well as the burner flame, making sure it is steady, not lifting or floating. If there is a problem, call a qualified service person.
5. The appliance and venting system must be inspected before use and at least annually by a qualified field service person, to ensure the unobstructed flow of combustion and ventilation air.

During the annual service call, the burner should be removed from the burner tray and cleaned. Replace the embers but do not block the pilot.

CAUTION

- **Label all wires prior to disconnection when servicing controls. Wiring errors can cause improper and dangerous operation.**
- **Any safety screen or guard removed for servicing an appliance must be replaced prior to operating the appliance.**
- **Clothing or other flammable material should not be placed on or near the appliance.**

CHILDREN AND ADULTS SHOULD BE ALERTED TO THE HAZARDS OF HIGH SURFACE TEMPERATURE AND SHOULD STAY AWAY TO AVOID BURNS OR CLOTHING IGNITION. YOUNG CHILDREN SHOULD BE CAREFULLY SUPERVISED WHEN THEY ARE IN THE SAME ROOM AS THE APPLIANCE.

DO NOT USE THIS APPLIANCE IF ANY PART HAS BEEN UNDER WATER. IMMEDIATELY CALL A QUALIFIED SERVICE TECHNICIAN TO INSPECT THE APPLIANCE AND REPLACE ANY PART OF THE CONTROL SYSTEM AND ANY GAS CONTROL WHICH HAS BEEN UNDER WATER.

6. Keep the area near the appliance clear and free from combustible materials, gasoline, and other flammable vapours and liquids.
7. Condensation may fog the glass when the appliance is lit. This is normal and will disappear as the glass heats up.

**Never operate the appliance without the glass properly secured.**

8. Periodically check the pilot flames. Correct flame pattern has three strong blue flames: one flowing around the thermopile, one around the thermocouple, and one flowing across the rear of the burner (it does not have to be touching the burner).

**NOTE** If you have an incorrect flame pattern, contact your Regency® dealer for further instructions.

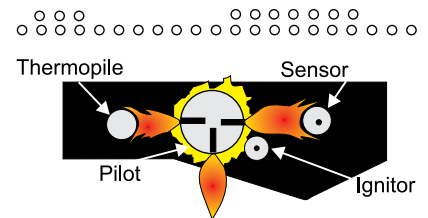

Top View of Pilot Flame

Incorrect flame pattern will have small, probably yellow flames, not coming into proper contact with the rear of the burner.

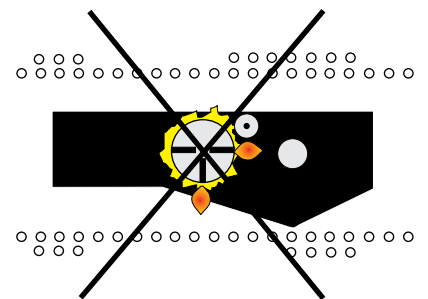

Top View of Pilot Flame

9. Verify operation after servicing.

# maintenance

## Door Glass

Your Regency insert is supplied with high-temperature Neoceram glass that will withstand the highest heat your unit can produce. If your glass requires cleaning, we recommend using an approved glass cleaner available at all authorized dealers. Do not use abrasive materials. Do not clean the glass when hot.

If you break the door glass, purchase a replacement from an authorized Regency dealer and follow our step-by-step instructions for replacement.

### CAUTIONS

- **Do not clean when the glass is hot.**
- **The use of substitute glass will void all product warranties.**
- **Take care not to break the glass.**
- **Do not operate this fireplace without the glass front, or with broken glass.**
- **Wear gloves when removing damaged or broken glass.**
- **Replacement of the glass panel(s) should be done by a qualified service person.**

## Glass Replacement

In the event that you break your glass, purchase your replacement from an authorized Regency® dealer.

Replacement ceramic glass (Part #940-536/P) is shipped with a gasket.

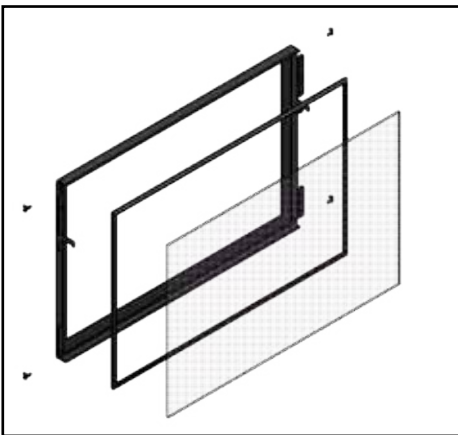

## General Vent Maintenance

Conduct an inspection of the venting system semiannually. Areas to inspect are as follows:

1. Check the venting system for corrosion in areas exposed to the elements. Components with rust spots, streaks, or holes should be replaced immediately.
2. Remove the termination cap and shine a flashlight down the vent. Remove any bird nests or other foreign material.
3. Check for evidence of excessive condensation, such as water droplets in the inner liner dripping out the joints. Continuous condensation can cause corrosion of caps, pipes, and fittings. It may be caused by excessive lateral runs, too many elbows, or exposure to cold weather.
4. Inspect joints to verify that no pipe sections or fittings have been disturbed and consequently loosened. Also, check mechanical supports such as wall straps or plumber's tape for rigidity.

## Log Replacement

Never use the unit with broken logs. Turn off the gas valve and allow the unit to cool before carefully removing the logs. Use the proper replacement log for any that are broken. Position the logs as shown in the diagram in the "Log Installation" section of this manual.

### NOTE

Improper positioning of logs may create carbon build-up and will alter the unit's performance which is not covered under warranty.

## Glass Gasket

If the glass gasket requires replacement, use Flush Front (Part # 846-700).

## Sparker Battery Change

1. Pull the sparker box out to access the battery cover.

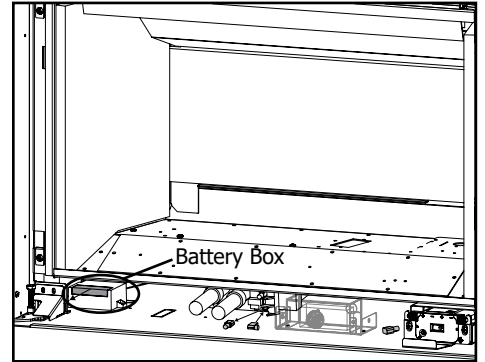

2. Compress the clip and remove the sparker battery cover.
3. Discard and replace the AA battery.
4. Replace battery cover and press down to close.

## Fan Replacement

**NOTE** To access the side and rear panels, disconnect the gas and venting (see the venting and flue installation sections in this manual for steps). You cannot access the blower from the front of the appliance.

1. Shut the power off.
2. From the back of the unit, remove the six screws, then lift the fan mount plate out.

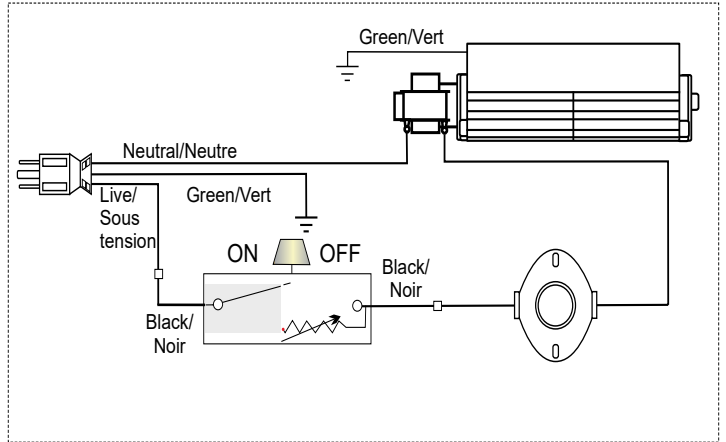
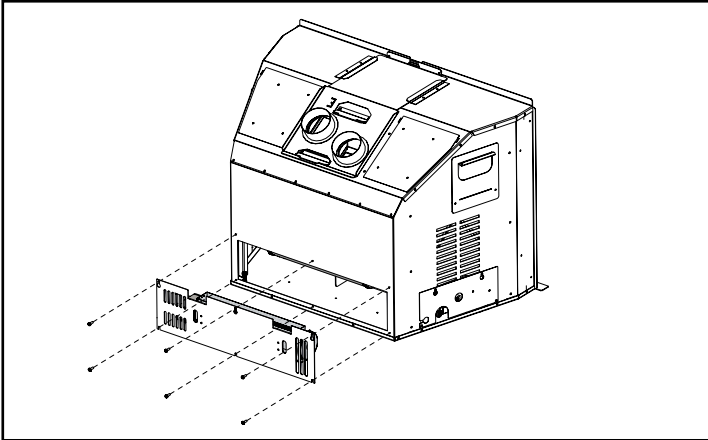

3. Remove the electrical access panel from the left side of the insert by removing five screws.

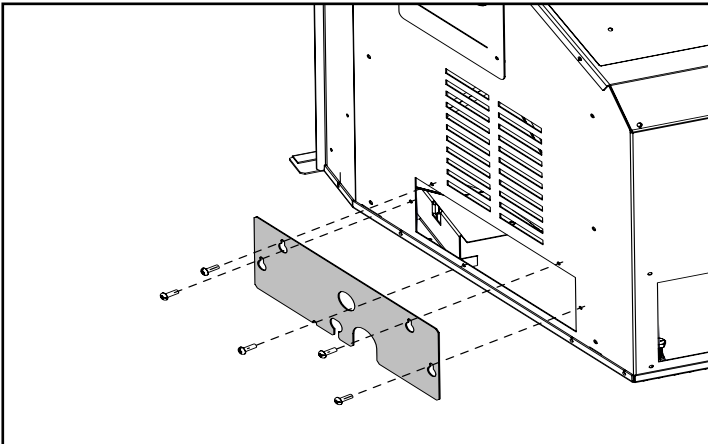

5. Remove the fan from the mounting plate by removing four screws from the outside of the fan access panel.

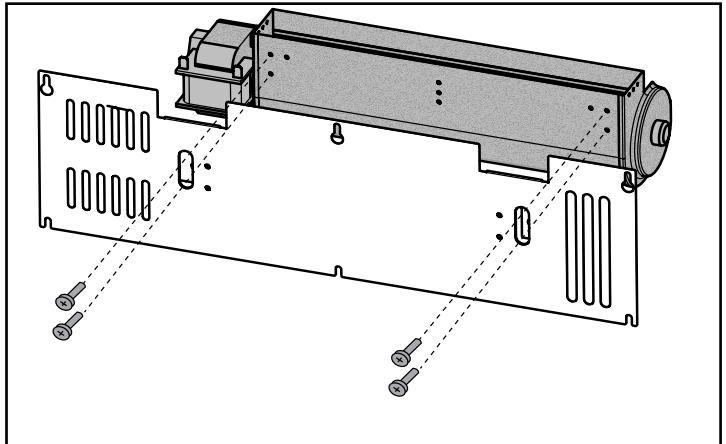

4. Disconnect the green ground wire on the right side of the unit (refer to wiring diagram).

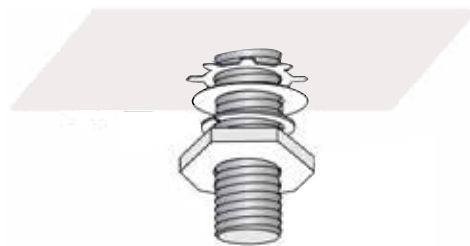
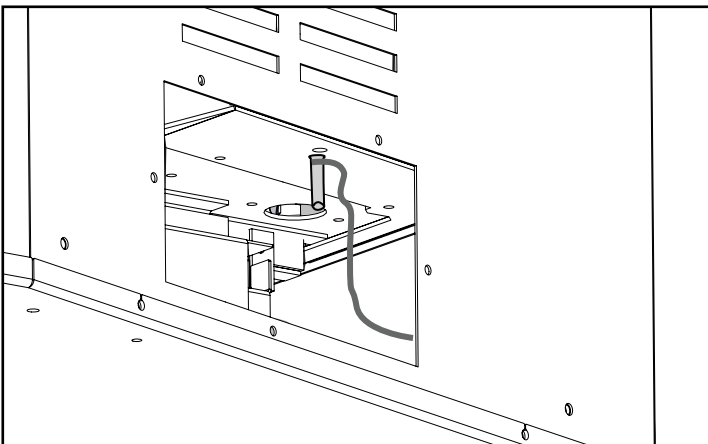

6. To install, reverse these steps.

# maintenance

## Valve Replacement

Before you begin:

- Shut off the gas supply to the unit.
- Disconnect all electrical supply to the unit.

**Always let the appliance cool to room temperature before servicing.**

**NOTE** • When the glass is cold and the appliance is lit, condensation may fog the glass. Condensation is normal and will disappear in a few minutes as the glass heats up.

1. Remove the pilot cover (3 screws).

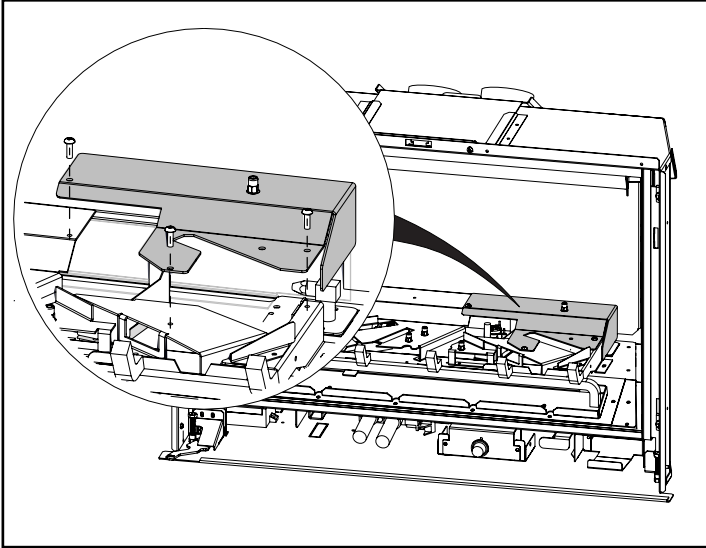

3. Slide burner tray to the left and out.

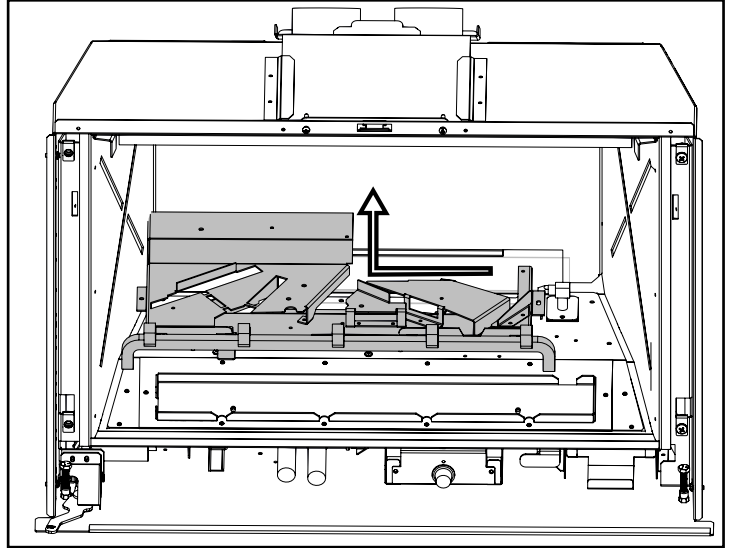

2. Remove the burner tray (2 screws).

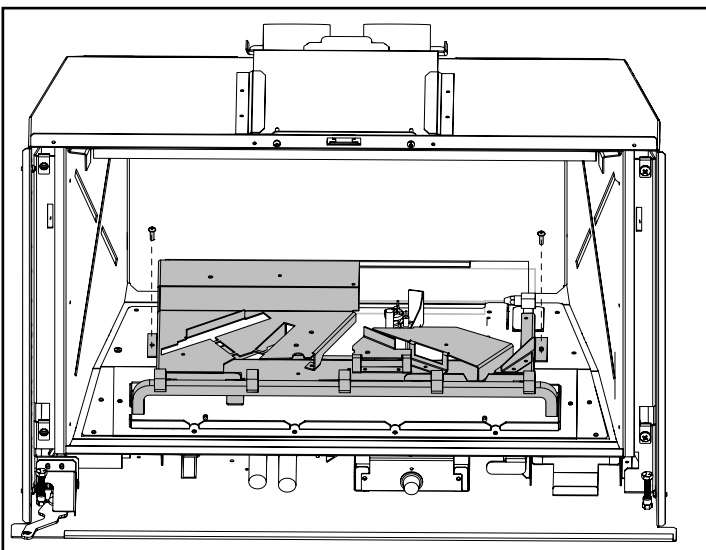

4. Disconnect remote receiver/ON/OFF switch wires from TH/TH-TP terminals on gas valve.

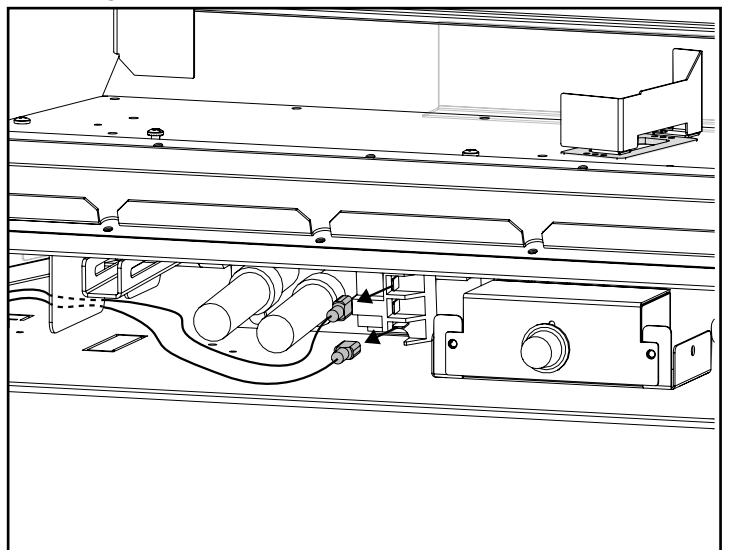



5. Disconnect the spark electrode & remove both extension knobs by pulling these out toward you.

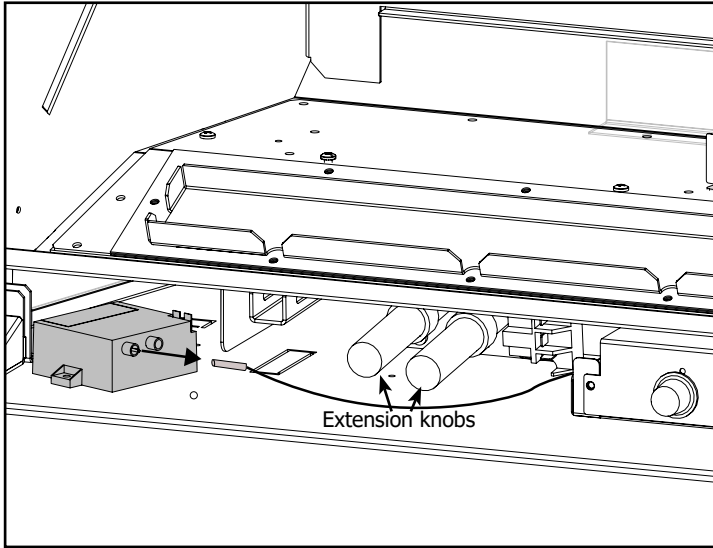

7. Remove the Phillips head screw securing the spark box switch.

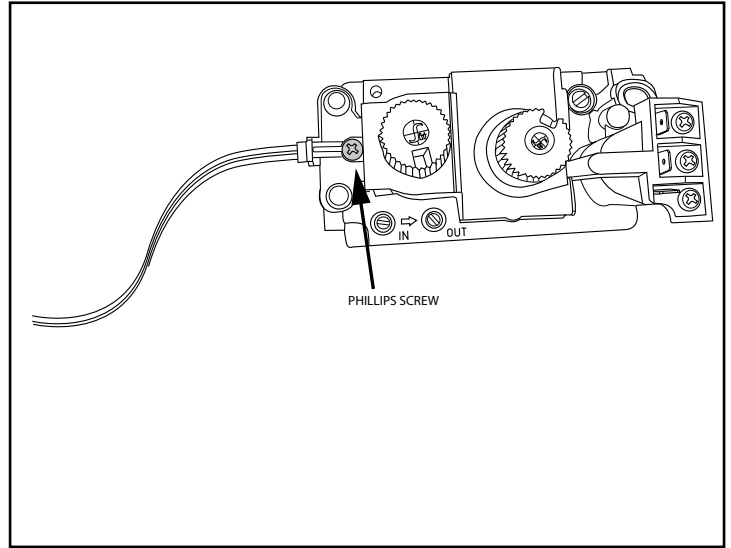

6. Remove the 16 screws securing the valve tray.

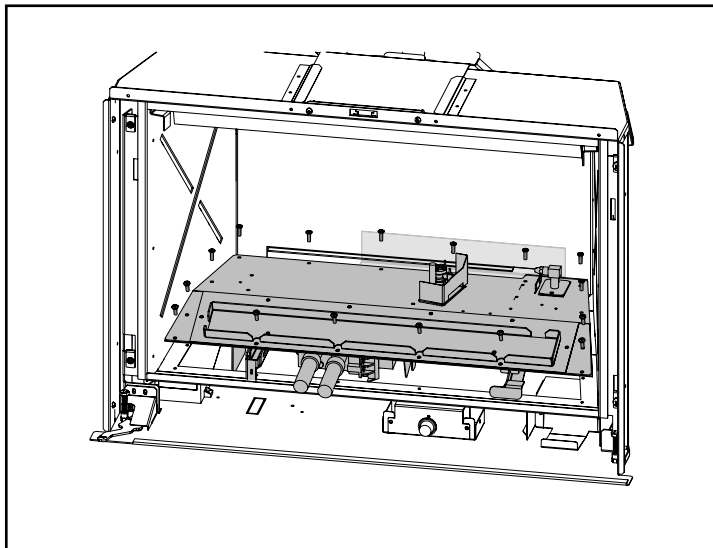

8. Disconnect gas line from the unit.

9. Remove valve assembly

10. Reverse steps 8-1 to replace with new gas valve assembly.

# maintenance

## Gas Maintenance - Recommended Annual Routine

In order for your Regency appliance to continue to provide comfort to your home periodic maintenance must be performed to ensure it is operating at peak efficiency. The items in the list should be checked by a licensed gas service technician during the annual service check. Your unit may require more frequent maintenance checks if you notice any changes in how it operates. Operational changes to look for can include, but are not limited to, extended start up time, increased fan noise, residue/carbon build up, white build up on the glass/firebox, increased operating noise etc. Should any of these or other conditions arise, discontinue use and schedule a service check with your local licensed gas technician. The list below shows items your licensed service technician will need to check and service at least annually.

### Clean

- Glass
- Interior bricks / panels
- Burner ports & burner air shutter
- Fan blades
- Log set
- Pilot orifices
- Pilot hood (change as needed)
- Flame sensor (electronic ignition models)
- Flame electrode
- Burner orifice
- Thermocouple (millivolt models)
- Thermopile (millivolt models)

### Inspect

- Pilot assembly
- Burner
- Pressure relief gaskets/doors
- Flue connector gasket if present
- Door seal
- Firebox
- Venting
- Batteries (remote handheld, remote receiver, DC sparker, change as needed)
- Burner media (change as needed)
- Air shutter setting
- Wiring

### Check

- Voltage on thermocouple/thermopile (millivolt models)
- Ohms reading on flame sense (electronic ignition models)
- Inlet/outlet fuel pressures as per rating plate
- Voltage/ohms readings on gas valve
- Ohms reading to on/off switch circuit (Millivolt models)

### Gas Leak Tests

- Check main gas line connection to valve
- Check shut off valve connections
- Check connection at gas valve outlet
- Check connection at main burner orifice
- Check pilot fuel line at valve and at pilot assembly

Parts - Main Assembly

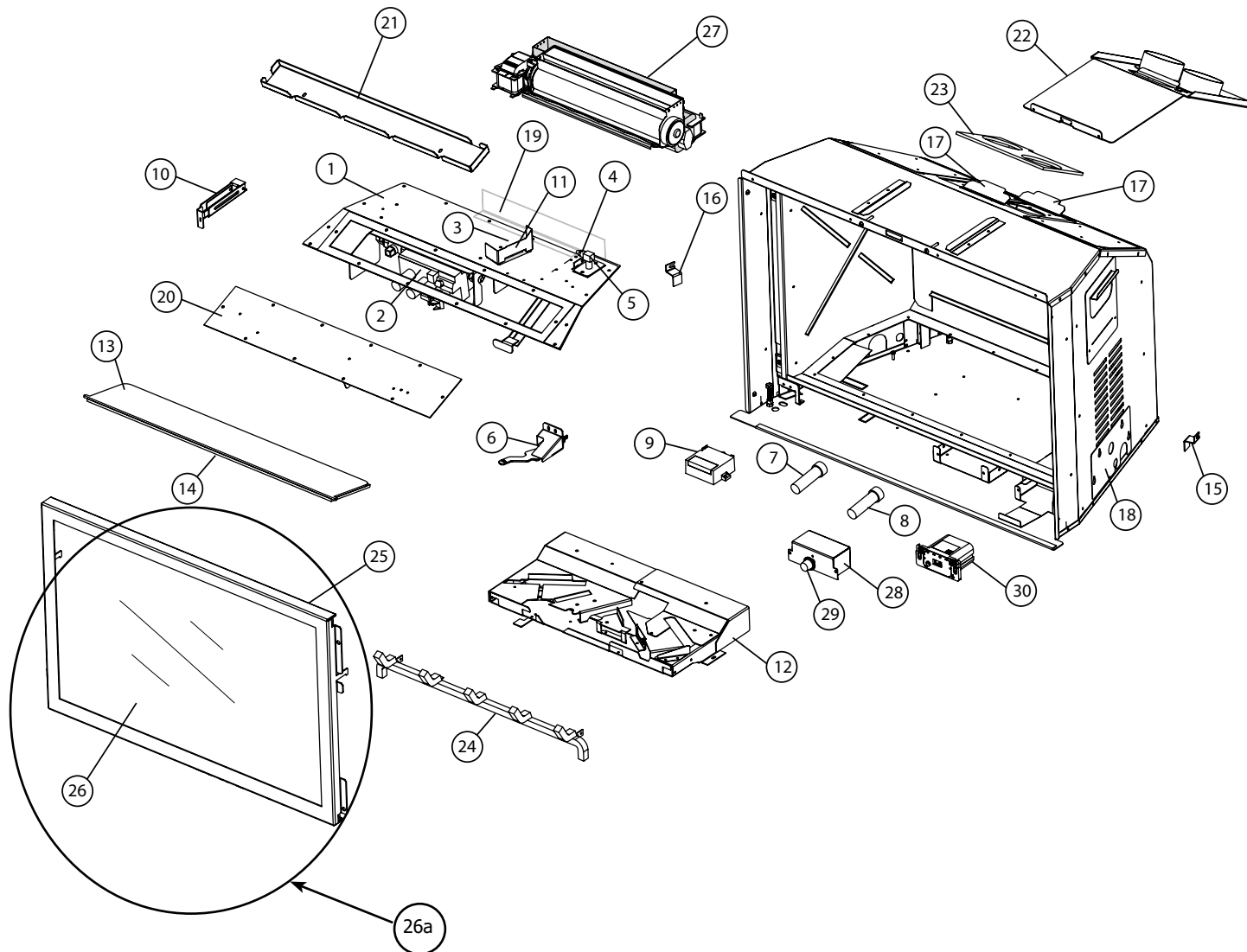

# parts list

## Parts - Main Assembly

ITEM	PART #	DESCRIPTION
1	311-774/P	Valve Assembly - NG
1	311-776/P	Valve Assembly - LP
2	910-478	Valve NG/LP SIT High/Low 820.844
3	910-038/P	Novasit Pilot Assembly - NG 0.199.769
3	910-039/P	Novasit Pilot Assembly - LP 0.199.768
4	905-069	Burner Orifice #38 NG (PO512)
4	905-064	Burner Orifice #52 LP (PO512)
5	904-943	Brack Dormont Orifice Mnt 10-BZ001-19.5
6	311-526	ON/OFF Switch Assembly - Complete
7	910-421	Knob Ext. Pilot On/Off 3 in 916.188
8	910-422	Knob Extension Hi/Low 3 inch 916.189
9	910-073	Spark Generator Battery Holder
10	312-056	Gas Shutoff
11	312-121	Pilot Shield
12	312-510	Burner Tray
13	311-026F	Pressure Relief Plate Center
14	311-060	Pressure Relief Gasket
15	311-200	Inner Panel Retainer Clip Right
16	311-201	Inner Panel Retainer Clip Left
17	311-108	Bracket Flue
18	311-120F	Right Plate Gas/Electrical Access
19	311-084	Perforated Diffuser
20	312-046F	Plate Access
21	312-058	Ember Tray Standing Pilot
22	311-518	Flue Adaptor Assembly
23	311-046	Gasket Draft hood
24	311-513	Grate
25	311-529	Door Frame
26	940-536/P	Replacement Glass Includes Glass Gasket
26a	311-514	Door Glass Frame Assembly Complete ( Includes Glass/Glass Gasket)
27	911-071/P	Replacement Fan Motor
28	312-037	Fan Speed Controller Assembly
29	904-586	Fan Speed Control Knob C/W 0.250 x 0.156 Spring Clip Black
30	911-338/P	Remote Receiver
N/S = Not Shown		
N/S	910-036	Novasit Pilot Orifice NG # 51
N/S	910-037	Novasit Pilot Orifice LP # 30
N/S	W840470	Pilot Assembly Gasket
N/S	910-941	4 mm Valve Screw With Red O-Ring
N/S	910-940	Black Protective Cap
N/S	910-341	Thermopile 0.940.002

ITEM	PART #	DESCRIPTION
N/S	910-386	Quick Dropout Thermocouple 0.290.216
N/S	910-096	Novasit Pilot Hood 3 Way
N/S	910-432	Novasit Pilot Tubing With Nuts
N/S	911-137	Pilot Hood Clip
N/S	910-030	Novasit Electrode - Short 0.915.075
N/S	904-529	Allen Key 5/32 Long
N/S	656-039	Burner Orifice Mount Gasket
N/S	904-658	Inlet Flex Line Gas S.S. 24 inch
N/S	905-066	Ball Valve 1/2" Female to 1/2" Female Shut-off
N/S	905-067	Nipple 1/2 NPT X 3/8 NPT Hex
N/S	905-070	Cotter Pin 1/8" Dia x 1-1/8" Long
N/S	904-165	Fitting 3/8 Male Flarex Mpt Straight Adaptor
N/S	910-074	Spark Generator Switch c/w Wire
N/S	312-052	Gasket Valve Tray Standing Pilot
N/S	396-042F	Plate Slide & Door Frame Tool
N/S	311-031	Baffle
N/S	311-118	Left Plate Electrical/Gas Access Assembly
N/S	311-111F	Plate Restrictor
N/S	311-525	Burner Assembly NG/LP c/w Cap
N/S	846-700	Glass Gasket Tadpole Tape 6AL 1/2" Bulb Graphite w/1"PSA (7') (936-273)
N/S	904-691	Clip-U (Each)
N/S	W241050	Fan Thermodisc 60T12 610049
N/S	910-330	Speed Control Fan w/Connectors
N/S	910-692	Fan/Valve Wire Ground 24 inch (Green)
N/S	910-896	Fan Wire High Temp (Black)
N/S	911-096	Fan Power Cord 120 Volts w/Connector
N/S	920-169	Decal Fan Speed
N/S	910-818	Valve Switch Wire (Black)
N/S	904-030	Pressure Relief Bolt 1/4-20 x 1 Zinc Plated (each)
N/S	911-308	Remote Receiver Wire (Each)
N/S	910-811	Burner Switch/Remote Receiver Extension Wire
N/S	904-948	Levelling Bolt 1/4-20 x 2-1/2 Hex Hd Zinc Pd Full Thread (Each)
N/S	920-391	Manual
N/S	904-918	Front Levelling Bolt 1/4-20 x 3/4 Hex Hd Blk Oxide
N/S	910-592-OFT	Remote Transmitter
N/S	911-210	Antenna
N/S	911-417	Black Jumper Wire
N/S	911-164	Remote Wiring Harness
N/S	311-044	Blocker/Top Front Heat Deflector

Faceplates/Accessories

ITEM	PART #	DESCRIPTION
1	312-936 311-937 311-938	Backing Plate Oversized Backing Plate Custom 3-Sided* Backing Plate Custom 4-Sided*
2	312-193	Bracket Backing Plate
3	311-920 311-921 311-922 311-923 311-924 311-927 311-928	Premium Faceplate Surround Black Premium Faceplate Surround Grey Premium Faceplate Surround White Premium Faceplate Surround Sunset Bronze Premium Faceplate Surround Brushed Nickel Traditional Surround Black Traditional Surround Brushed Antique Copper
4	311-910 311-912 311-913 311-914 311-915	Faceplate Regular 3-Sided Black Faceplate Flush 3-Sided Black Faceplate Flush 4-Sided Black Finishing Trim 3-Sided Black Finishing Trim 4-Sided Black
5	312-013	Compact Screen Arm L/H
6	312-014	Compact Screen Arm R/H
7	312-015 312-016 312-070	Compact Screen Angle Panel L/H Compact Screen Angle Panel R/H Compact Screen Cover
8	311-417/P	Mesh Glass Guard Compact Invisi
9	312-012	Compact Screen Frame
10	312-219	Compact Screen Logo Bracket

ITEM	PART #	DESCRIPTION
N/S	311-940	Mantel Deflector
N/S	311-941	Adjustable Hearth Trim
N/S	311-934	Oak Log Set
N/S	311-931	Birch Log Set
N/S	311-930/P	Driftwood Log Set
N/S	946-783	Andiron Lava Embers
N/S	946-780	Crushed Glass - Coal Black 3/4 in 3.5 lbs
N/S	946-781	Crushed Glass - Iceberg 3/4 in 3.5 lbs
N/S	946-779	Crushed Glass - Ginger 3/4 in 3.5 lbs
N/S	311-901	Brick Panel Standard Brown
N/S	311-903	Brick Panel Herringbone
N/S	311-904	Brick Panel Castle Stone Grey
N/S	311-905	Brick Panel Volcanic Black
N/S	311-906	Inner Panel Glass Black Gi29
N/S	311-907	Inner Panel Black
N/S	311-980	Derating Orifice NG
N/S	311-935	Grate & Ember Media
N/S	311-978	NG Conversion Kit
N/S	311-977	LP Conversion Kit

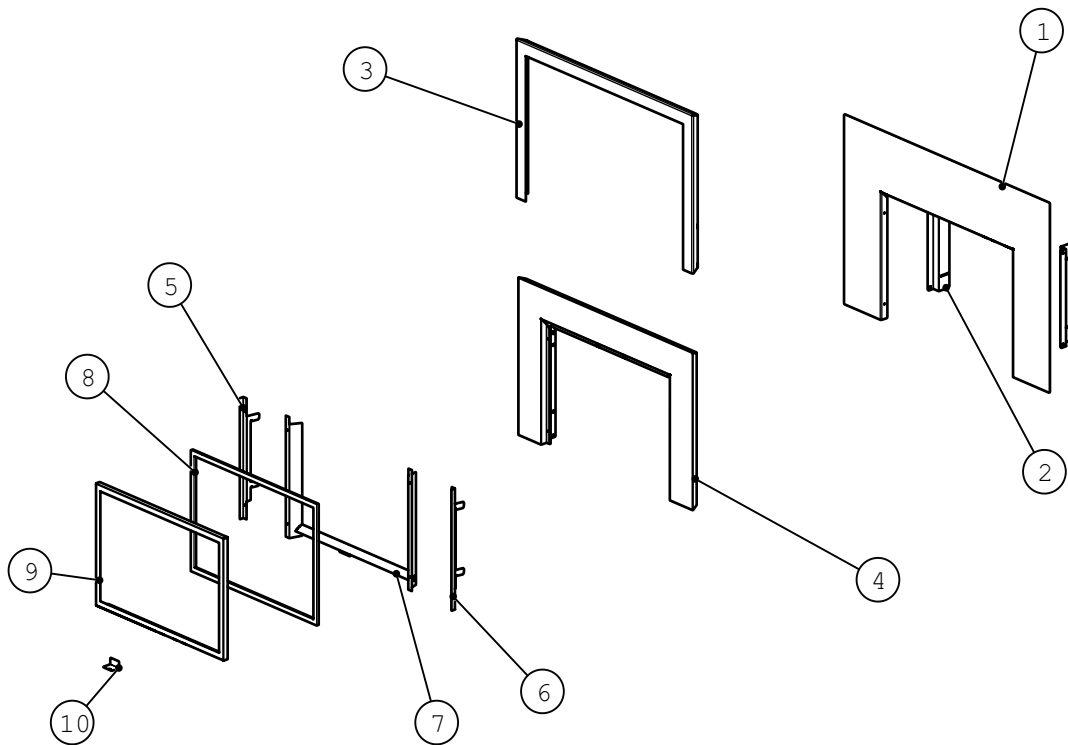

## Indoor Gas Product Warranty

### Limited Lifetime Warranty

FPI Fireplace Products International Ltd. (for Canadian customers) and Fireplace Products US, Inc. (for US customers) (collectively referred to herein as “FPI”) extends this Limited Lifetime Warranty to the original purchaser of this Appliance provided the product remains in the original place of installation. The items covered by this Limited Lifetime Warranty and the period of such coverage are set forth in the table below.

An Appliance in this policy is defined as an Indoor Gas Fireplace, Indoor Gas Insert, Indoor Gas Freestanding Stove.

**This Appliance has only been certified and listed for use indoors.**

This Limited Lifetime Warranty starts on the day the Appliance was purchased.

**The Limited Lifetime Warranty is not transferable, amendable or negotiable under any circumstances.**

Indoor Gas Products Warranty Coverage Parts and Labor	Limited Lifetime	5 years	2 years	1 year	Subsidized Labor Coverage* (Years)
Firebox and Heat Exchanger	✓				3
Steel Burner Tube	✓				3
Glass Thermal breakage only	✓				3
All painted Surrounds/Inlays Finishes		✓			3
Brick Panels/Log sets/Ceramic Burners		✓			3
All Castings		✓			3
Valve assembly and all gas control components (Pilot assembly, flame sensors, Spark Electrode, Pilot Tubing, Orifices, Thermocouple, Thermopile)			✓		2
All Other Electrical components (Ignition Control Boards, Wiring, Switches, Blowers, Blower Control Module, Battery Pack, Remote Control Systems)			✓		2
Enamel Panels			✓		1
Venting/Venting Components			✓		1
All Stainless steel surrounds All black chrome Brushed nickel/Antique copper Faceplates/surrounds All Inner/Outer Black Glass panels				✓	1
All Firebox Media (Crystals, Fire beads, Volcanic, Ceramic, Spa Stones, River Pebbles)				✓	1
All hardware				✓	1
WIFI Dongle				✓	1
Mesh/Glass Safety Barriers				✓	1
Accent Light Bulbs				✓	1
Glass (Crazing)				✓	1

**Note:** Warranty coverage noted above may not be applicable as components/options vary based on appliance purchased.

### Conditions:

Warranty protects against defect in manufacture or FPI factory-assembled components only, unless herein specified otherwise.

**\*This warranty does not cover dealer travel costs, mileage, fuel, tolls for diagnostic or service work. All labor rates paid to authorized dealers are subsidized, pre-determined rates. Dealers may charge you for travel and additional time beyond their subsidy.**

Any part(s) found to be defective during the warranty period as outlined above will be repaired or replaced at FPI's option through an accredited distributor, dealer or pre-approved and assigned agent; provided that the defective part is returned to the distributor, dealer or agent for inspection if requested by FPI. Alternatively, FPI may, at its discretion, fully discharge all of its obligations under warranty by refunding the verified purchase price of the product to the original purchaser. The purchase price must be confirmed by the original Bill of Sale. **The authorized selling dealer, or an alternative authorized FPI dealer if pre-approved by FPI, is responsible for all in-field diagnosis and service work related to all warranty claims. FPI is not responsible for results or costs of workmanship of unauthorized FPI dealers or agents in the negligence of their service work.**

At all times, FPI reserves the right to inspect reported in the field/on location complaints of products claimed to be defective before processing or authorizing any claim. Failure to allow this upon request will void the warranty.

All warranty claims must be submitted by the dealer servicing the claim, including a copy of the Bill of Sale (proof of purchase by you). All claims must be complete and provide full details as requested by FPI to receive consideration for evaluation. **Incomplete claims may be rejected.**

**Replacement Appliances to the original purchaser are limited to one per warranty term.** Appliances must be installed according to all manufacturers' instructions as per the manual. All Local and National required codes must be met.

The installer is responsible for ensuring the Appliance is operating as designed at the time of installation.

The original purchaser is responsible for the annual maintenance of the Appliance, as outlined in the owner's manual. As outlined below, the warranty may be voided due to problems caused by a lack of maintenance.

Purchased parts: Repair/replacement parts purchased by the consumer from FPI after the original coverage has expired on the Appliance will carry a **90-day** warranty from the purchase date, valid with a receipt only. Any item shown to be defective will be repaired or replaced at our discretion. No labor coverage is included with these parts.

Special Finishes - One year on brushed nickel, black chrome and antique copper faceplates/surrounds. You can expect some changes in color as the product "ages" with constant heating and cooling. FPI warrants the product for any manufacturing defects on the original product. However, the manufacturer's warranty does not cover changing colors and marks, i.e. fingerprints, etc. applied after the purchase of the product. Damage from the use of abrasive cleaners is not covered by warranty.

If freight damage has been found either externally or internally, the dealer must be informed within 3 days. All claims as a result of damage must be submitted by the dealer servicing the claim, including a copy of the Bill of Sale (proof of purchase). All claims must be complete and provide full details as requested by FPI to receive consideration for evaluation. **Incomplete claims may be rejected.**

As this is a Limited Lifetime Warranty, if the Appliance needs to be replaced, the Appliance that was purchased at the time of sale might not be replaced with exactly the same model Appliance. In that case, FPI will replace your Appliance with one that is similar at the time of replacement under the terms of this Limited Lifetime Warranty, but **ONLY** in the event that an item covered by the Limited Lifetime Warranty is found to be defective. Please refer to the table on first page of this warranty for items covered by the Limited Lifetime Warranty. Product changes might be the result of the original Appliance being discontinued, changes in regulatory requirements, product advancements, etc., which are beyond the control of FPI. **This Limited Lifetime Warranty does not cover any installation costs, or costs associated with changes of required clearances for the replacement Appliance, hearth pads, mantles, facing and/or facing materials such as framing, completed walls made of drywall, wood, non-combustible board, tile, brick, stone, marble etc., venting/chimney systems, or components of the chimney system.**

If a suitable replacement is not available, FPI will refund **50%** of the purchase price of the Appliance and any applicable FPI accessories (faceplates, brick panels, media, etc.) purchased at the time of sale. **In no event will FPI refund any portion of the purchase price of, or reimburse costs associated with, any other items, including without limitation, installation of a new Appliance, changes of required clearances for a new Appliance, hearth pads, mantles, facing and/or facing materials such as framing, completed walls made of drywall, wood, non-combustible board, tile, brick, stone, marble etc., venting/chimney systems, or components of the chimney system. A copy of the receipt or bill of sale will be necessary to validate the purchase price.**

# warranty

## **Exclusions:**

This Limited Lifetime Warranty does not extend to paint, rust or corrosion of any kind due to a lack of maintenance or improper venting, combustion air provision, corrosive chemicals (i.e. chlorine, salt, air, etc.), door or glass gasketing, batteries, color fading, carbon/sooting of the log sets due to use and does not cover lava rock, platinum/glowing embers, vermiculite.

Malfunction, damage or performance-based issues as a result of environmental conditions, location, chemical damages, downdrafts, installation error, an installation by an unqualified installer, incorrect chimney components (including but not limited to cap size or type), operator error, abuse, misuse, use of improper fuels, lack of regular maintenance and upkeep, acts of God, weather-related problems from hurricanes, tornados, earthquakes, floods, lightning strikes/bolts or acts of terrorism or war, which result in a malfunction of the Appliance are not covered under the terms of this Limited Lifetime Warranty.

FPI has no obligation to enhance or modify any Appliance once manufactured (i.e. as products evolve, field modifications or upgrades will not be performed on existing Appliances).

Any Appliance showing signs of neglect or misuse will not be covered under the terms of this warranty policy and may void this warranty, including Appliances with rusted or corroded fireboxes that have not been reported as rusted or corroded within **three (3)** months of installation/purchase.

Appliances which show evidence of being operated while damaged, or with problems known to the purchaser and causing further damages will void this warranty.

Appliances where the serial no. has been altered, deleted, removed or made illegible will void this warranty.

Minor movement, expansion and contraction of the steel is normal and is not covered under the terms of this warranty.

Freight damages for products or parts are not covered under the terms of the warranty.

Products made or provided by other manufacturers and used in conjunction with the FPI Appliance without prior authorization from FPI may void this warranty.

## **Limitations of Liability:**

The original purchaser's exclusive remedy under this warranty, and FPI's sole obligation under this Limited Lifetime Warranty, express or implied, in contract or in tort, shall be limited to replacement, repair, or refund, as outlined above. IN NO EVENT WILL FPI BE LIABLE UNDER THIS WARRANTY FOR ANY INCIDENTAL OR CONSEQUENTIAL COMMERCIAL DAMAGES OR DAMAGES TO PROPERTY. TO THE EXTENT PERMITTED BY APPLICABLE LAW, FPI MAKES NO EXPRESS WARRANTIES OTHER THAN THE WARRANTY SPECIFIED HEREIN. THE DURATION OF ANY IMPLIED WARRANTY IS LIMITED TO DURATION OF THE EXPRESSED WARRANTY SPECIFIED ABOVE. IF IMPLIED WARRANTIES CANNOT BE DISCLAIMED, THEN SUCH WARRANTIES ARE LIMITED IN DURATION TO THE DURATION OF THIS WARRANTY.

Some US states do not allow limitations on how long an implied warranty lasts, or allow exclusion or limitation of incidental or consequential damages, so the above limitations or exclusions may not apply to you.

Customers located outside the US should consult their local, provincial or national legal codes for additional terms, which may apply to this warranty.



**How to Obtain Warranty Service:**

Customers should contact the authorized selling dealer to obtain warranty service. In the event the authorized selling dealer is unable to provide warranty service, please contact FPI by mail at the address listed below. Please include a brief description of the problem and your address, email and telephone contact information. A representative will contact you to make arrangements for an inspection and/or warranty service.

Canadian Warrantor:**FPI Fireplace Products International Ltd.**

6988 Venture St.  
Delta, British Columbia  
Canada, V4G 1H4

U.S. Warrantor:**Fireplace Products US, Inc.**

PO Box 2189 PMB 125  
Blaine, WA  
United States, 98231

Or contact the Regency Customer Care Centre at 1-800-442-7432 (phone) / 604-946-4349 (fax)  
/customerservice@regency-fire.com (e-mail)

**Product Registration and Customer Support:**

Thank you for choosing a Regency Fireplace. Regency strives to be a world leader in the design, manufacture, and marketing of hearth products. To provide the best support for your product, we request that you complete a product registration form at <http://www.regency-fire.com/Customer-Care/Warranty-Registration.aspx> within **ninety (90)** days of purchase.

# Warranty Registration Card



**Product Registration and Customer Support:**

Thank you for choosing a Regency Fireplace. Regency strives to be a world leader in the design, manufacture, and marketing of hearth products. To provide the best support for your product, we request that you complete a product registration form found on our Web Site under Customer Care within ninety (90) days of purchase.

For purchases made in **CANADA or the UNITED STATES:**

<http://www.regency-fire.com/Customer-Care/Warranty-Registration.aspx>

For purchases made in AUSTRALIA:

<http://www.regency-fire.com.au/Customer-Care/Warranty-Registration.aspx>

You may also complete the warranty registration form below to register your Regency Fireplace Product and mail and/or fax it back to us, and we will register the warranty for you. It is important you provide us with all the information below in order for us to serve you better.

**Warranty Registration Form (or Register online immediately at the above Web Site):**

<b>Warranty Details</b>	
Serial Number (required):	
Purchase Date (required) (mm/dd/yyyy):	
<b>Product Details</b>	
Product Model (required):	
<b>Dealer Details</b>	
Dealer Name (required):	
Dealer Address:	
Dealer Phone #:	
Installer:	
Date Installed (mm/dd/yyyy):	
<b>Your Contact Details (required)</b>	
Name:	
Address:	
Phone:	
Email:	

For purchases made in CANADA:

**FPI Fireplace Products International Ltd.**  
6988 Venture St.  
Delta, British Columbia  
Canada, V4G 1H4

Phone: 604-946-5155  
Fax: 1-866-393-2806

For purchases made in the UNITED STATES:

**Fireplace Products US, Inc.**  
PO Box 2189 PMB 125  
Blaine, WA  
United States, 98231

Phone: 604-946-5155  
Fax: 1-866-393-2806

For purchases made in AUSTRALIA:

**Fireplace Products Australia Pty Ltd**  
99 Colemans Road  
Dandenong South, Vic.  
Australia, 3175

Phone: +61 3 9799 7277  
Fax: +61 3 9799 7822

For fireplace care and tips and answers to most common questions please visit our Customer Care section on our Web Site. Please feel free to contact your selling dealer if you have any questions about your Regency product.



# recycling

**PRODUCT LIFE CYCLE:**

By recycling your used appliances, you divert waste from your local landfills and help the environment. You also reduce the need for raw materials to manufacture new products. Contact your local municipality for appliance recycling services, local recycling programs, or appliance removal services to ensure your Regency appliance components, and packaging are properly recycled.







***Installer: Please complete the following information***

Dealer Name & Address: \_\_\_\_\_

\_\_\_\_\_

Installer: \_\_\_\_\_

Phone #: \_\_\_\_\_

Date Installed: \_\_\_\_\_

Serial #: \_\_\_\_\_