



Riva2 670 Electric

LED Electric Fire
with Thermostatic Remote Control



Instructions for Use, Installation & Servicing

For use in AU & NZ (Australia & New Zealand)

IMPORTANT

PARTS OF THE OUTER CASING OF THIS APPLIANCE ARE CONSIDERED BY THE MANUFACTURER TO BE A WORKING SURFACE WHICH BECOMES HOT WHEN THE HEATER IS IN OPERATION AND WILL RESULT IN SERIOUS INJURY AND BURNS IF TOUCHED. IT IS THEREFORE RECOMMENDED THAT A FIREGUARD IS USED IN THE PRESENCE OF YOUNG CHILDREN, THE ELDERLY OR INFIRM.

THE HEATER OUTLET GRILLE BECOMES VERY HOT WHILST IN OPERATION.
DO NOT COVER THE OUTLET GRILLE OR ANY PART OF THE APPLIANCE.

For use with 230V 50Hz electricity supply only.
Please read these instructions carefully before installation and keep them in a safe place.
They will be needed when maintenance or servicing is required.

THIS APPLIANCE MUST BE EARTHED

THIS PRODUCT IS ONLY SUITABLE FOR WELL INSULATED SPACES AND OCCASIONAL USE.

CONTENTS

RIVA2 670 - LED ELECTRIC FIRE

Covering the following models:

ELECTRIC RIVA2 670

234-872AZ

User Instructions	3
Installation Instructions	9
Technical Specifications	9
Installation	12
Servicing Requirements	15
Pairing the Remote.....	18
Wiring Diagram.....	20
Spares List	21
Warranty.....	22

WARRANTY

This system carries a 12 month parts-labour warranty. Please note that all warranties are effective from the date of purchase.



Tested to AS/NZS 60335.2.30:2015 &
AS/NZS 60335.1:2011
Certificate Number AZ69022563

USER INSTRUCTIONS

IMPORTANT INFORMATION AND HEALTH AND SAFETY

Read all of the instructions carefully before using the appliance.

Remove all packaging and dispose of at an appropriate recycling facility.

Do not locate this appliance immediately below a fixed socket outlet.

Parts of the outer casing of this appliance are considered by the manufacturer to be a working surface which becomes hot when the heater is switched on. You must use a suitable fire guard to protect children, the elderly and the infirm.

Do not use this appliance in the immediate surroundings of a bath, shower, swimming pool or any other area where the appliance could come into contact with water or humidity, e.g. a bathroom.



WARNING! DO NOT COVER

Do not allow the appliance to be covered or let the air inlet/outlet become obstructed as the appliance may overheat. Please note the warning symbol on the appliance (see above).

For indoor use only. This appliance is not suitable for use outside the house.

This appliance must be installed in a purpose built studwork enclosure. Ensure the appliance is level and that furniture, curtains etc. are positioned no closer than 1m.

Where the electricity supply cable has to pass through a fire place, stone surround etc. ensure suitable rubber bushes are fitted at possible wear points.

If installed in an open fireplace, blank off the chimney to **reduce the risk of a back draught which can cause the safety cut-out to operate.**

Keep the power cord away from hot surfaces and hot conditions. Do not route the power lead in front of the appliance.

When the fire has been installed the position of the plug must be accessible.

If the electricity supply cable is damaged do not use the appliance until it has been replaced. For safety reasons the replacement has to be carried out by a Gazco service agent or a similarly competent electrician.

CAUTION: In order to avoid a hazard due to inadvertent resetting of the thermal cut-out, this appliance must not be supplied through an external switching device, such as a timer, or connected to a circuit that is regularly switched on and off by the utility.

Do not operate the appliance if it is damaged.

Repairs of electrical appliances must only be performed by a suitably qualified person. Should the appliance fail to operate, or in case of any damage, please contact the retailer from whom the appliance was purchased.

This appliance can be used by children aged from 8 years and above and persons with reduced physical, sensory or mental capabilities or lack of experience and knowledge if they have been given supervision or instruction concerning use of the appliance in a safe way and understand the hazards involved. Children shall not play with the appliance. Cleaning and user maintenance shall not be made by children without supervision.

Children of less than 3 years should be kept away unless continuously supervised.

Children aged from 3 years and less than 8 years shall only switch on/off the appliance provided that it has been placed or installed in its intended normal operating position and they have been given supervision or instruction concerning use of the appliance in a safe way and understand the hazards involved. Children aged from 3 years and less than 8 years shall not plug in, regulate and clean the appliance or perform maintenance.

Caution: Some parts of this product can become very hot and cause burns. Particular attention has to be given where children and vulnerable people are present.

However Gazco recommend:

This appliance is not intended to be used by persons under the age of 12, persons with reduced physical, sensory or mental capabilities or persons with lack of experience and knowledge in the safe operation of the appliance.

The appliance may be operated by persons above the age of 12 provided they have been instructed in the safe use of the appliance and that they understand the hazards involved. Persons above the age of 12 may also operate the appliance under the supervision of a responsible adult.

Parts of this appliance become hot whilst in operation and under no circumstances should persons under the age of 12 be left alone with the product when it is in operation unless a suitable fireguard is used to protect them against the possibility of coming into direct contact with the appliance.

Children shall not play with the appliance.

Cleaning and user maintenance shall not be made by children without supervision.

OPERATING INSTRUCTIONS



WARNING! Do not operate the appliance if it is damaged or has malfunctioned. If you suspect the appliance is damaged or has malfunctioned call a suitably qualified person to inspect the appliance, and replace any part of the electrical system if necessary, before reuse.

Do not disconnect the power at the mains supply whilst the appliance is running. Use the functions on the remote to turn the fire off and ensure the mains switch has been moved to the off position before disconnecting.

GENERAL

The appliance can be operated by the radio frequency handset or the manual controls which are on the right hand side of the lower front panel.



NOTE: To use both remote and manual functions the manual on/off switch must be in 'ON' position. In order to prevent the product becoming too hot, there is 10s delay when turning on the heater and a 10s delay when turning off the heater fan.

The manual button controls basic functions, not a full range of controls. Use the remote hand set to carry out all functions.

PREPARATION BEFORE USE

Batteries:

Ensure that the handset battery is new and is inserted correctly.

Dispose of old batteries at an appropriate recycling facility.

LOCATION OF POWER SWITCH

The mains power switch is located on the control panel located on the right-hand side of the appliance behind the door of the frame, see Diagram.

Switch ON (—) before operating either the remote or manual controls.

A beep is heard to indicate the fire is ready for use.

MANUAL CONTROL PANEL

The manual controls on appliance are located on the right hand side of the lower front panel.

Turning on the appliance with the main power switch on '—' position. A long beep will be heard.

Press "LIGHTS ON/OFF" to turn on or turn off both the flame and fuel bed at the same time.

There are 3 flame colour options:

Press "FLAME" button to select the colour of flame (3 kinds of flame colour with flame) or return to the OFF position.

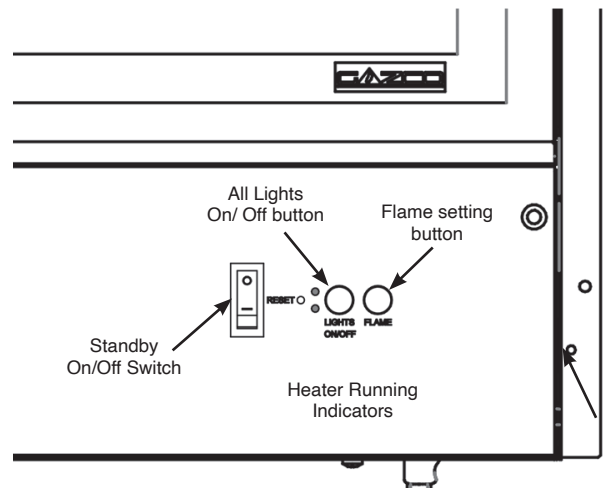

Note: The appliance will lose the memory for the light functions when the switch is set to the Off Position or the remote runs out of power.

HEATER RUNNING INDICATORS (SEE DIAGRAM)

When the fan heater is used in conjunction with the flame effect the heater running indicators will light up for 10 seconds.

The LEDs will illuminate for 10 seconds if the flame or fuel bed effect is On.

If the fan heater is used independently, the heater running indicators will stay on.

RESET BUTTON FOR REMOTE CONTROL

If the handset loses signal or needs to be replaced then, see Servicing Section for details.

REMOTE CONTROLS

The remote control should be left on a flat surface in the room where the appliance is installed and away from any direct flow of hot air.

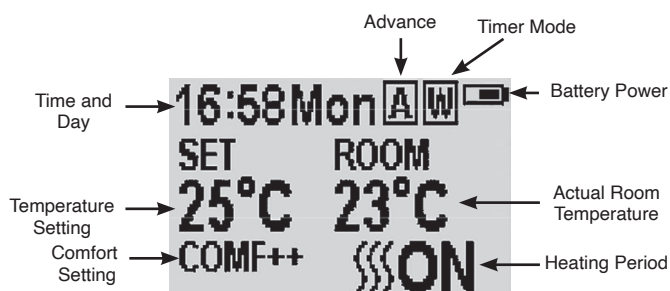
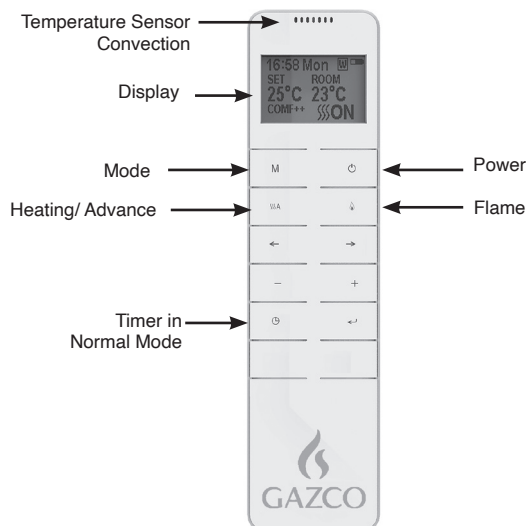

SIGNAL CODE

The remote control works by radio signal. The handheld transmitter is configured in the factory with a unique signal code.

IMPORTANT: If the handset loses signal or needs to be replaced, see Servicing Instructions Page 18-19.

TURN ON/OFF

Press  button to turn on the flame effect.

Press  button to turn off all the functions under the normal heating control mode including flame effect and fan heater.

Press  button to turn off the flame effect under daily and week timer heating mode.

WEEK DAYS/ TIME/ COMFORT TEMPERATURE AND UNIT SETTING

On activation it is recommended that the clock is reset to the correct time to ensure accuracy of the appliance operation.

Hold the **M** button for 3 seconds to enter the setting screen.

Press the '**←**' or '**→**' button to choose setting to change.

The selected character will be highlighted.

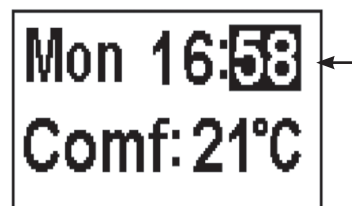

Press the '+' or '-' button to adjust the number.

Time: 24-hour system.
Select Comfort temperature from 15-25°C.
Temperature unit: °C/°F.

Press the  button for 3 seconds or wait 10 seconds to save and exit the week, time and heating temperature setting.

DAILY TIMER HEATING

The following heating periods have been preset, these can be altered if desired:

06:00 until 08:00
17:00 until 22:00

Press **M** until **D** shows at the upper right corner of the screen to enter the daily timer heating mode.

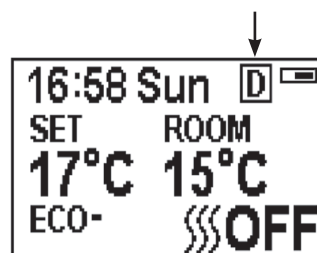

Hold the  button for 6 seconds to enter the daily heating setting. A maximum of 3 timed heating periods can be set per day.

Press '**←**' or '**→**' to choose hour or minute,

Press '+' or '-' to set the number.
The minute increment / decrement by 15min per press.

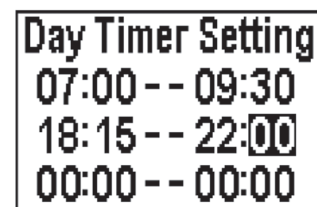

Hold the  button for 3 seconds or wait for 10 seconds to save and exit the heating time period setting.

Check the timer setting. Press  to check the daily timer mode.

If the heating needs to be turned off, it will be necessary to go back to the Normal Control Mode to it turn off.

When in Daily Timer Mode switching the appliance off with the remote will stop the light output. The heat output will continue according to the timer settings.

ADJUSTING THE SET TEMPERATURE

Press the '+' or '-' button to increase or decrease the temperature on the basis of COMF temperature.

COMF means the actual temperature is the same as setting.

ECO means the actual temperature is 2°C lower than the setting temperature.

ECO- means 4°C lower.

COMF+ means 2°C higher.

COMF++ means 4°C higher.

ADAPTIVE START CONTROL

According to room temperature and set-pointed temperature, the heater will automatically determine the appropriate time to heat to ensure that it will reach the set-pointed temperature in the set time (up to 45 minutes prior to the set time).

FLAME COLOUR ADJUSTMENT

Press button to enter the flame adjustment screen.

There are 3 flame colour options, indicated by the number shown in Diagram.

There are 6 levels of brightness, including off. This is indicated by the bar, with the blank bar indicating off, see Diagram.



Press the '<' or '>' button to cycle through the flame colour options.

Press the '+' button to increase the flame brightness.

Press the '-' button to decrease the flame brightness until off.

NORMAL CONTROL MODE

Normal Control Mode is the default setting.

Alternatively press **M** button until the **N** logo is shown at the upper right corner of the screen, see Diagram.

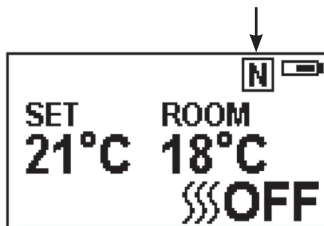

Press the '+' or '-' button to adjust the setting temperature from 17 °C to 25°C.

Press **[[[A** button to turn the heat on/off, **[[[ON** or **[[[OFF** will show at the lower right corner of the screen, see Diagram below.

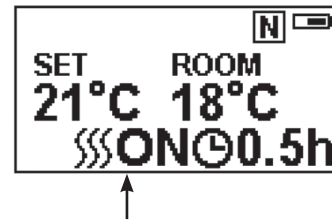

Note: It is normal for the fan heater to stop running for periods of time. This happens if the room temperature is higher than the temperature set on the control.

The heater indicator will be turned off after 10s if the flame is switched ON. The heater indicator will stay ON if only the heating function is used.

When in Normal Control Mode switching the appliance off with the remote will stop both the light and heat output.

COUNT DOWN TIMER

This setting is only in normal heating control mode. It allows the appliance to be returned to Standby after a set period of time. The heater must be switched on to use this function.

Press to cycle through the setting from Off and 0.5 hours to 9 hours. Timer logo and remaining time will show on the screen.

The heater of appliance can be automatically run by using daily timer and weekly timer on the remote.

BATTERY

The battery power level is indicated at the top right of the remote control screen.

	Battery Full	No action required
	Battery Half Power	Ensure new batteries are available.
	Battery Empty	Replace batteries immediately

Battery replacement is recommended after 1 year. The Remote requires two 1.5V alkaline AAA batteries.

Changing the batteries will not affect the Timer Mode settings, however, the clock may need adjusting.

WEEK TIMER HEATING

The following heating periods have been preset, these can be altered if desired:

From Monday to Friday
06:00 until 08:30
17:00 until 22:00

From Saturday to Sunday
06:30 until 09:30
11:00 until 13:00
17:00 until 22:00

Press **M** until **W** shows at the upper right corner of the screen to enter the week heating mode.

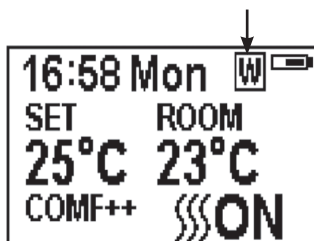

Hold the **←** button for 6 seconds to enter the week timer heating mode setting.

Press '**←**' or '**→**' to move the cursor (a flashing underline).

Press the **←** button in the corresponding week position to select (the character is highlighted) or cancel (the character is displayed normally) the current setting, the same time period can be selected together.

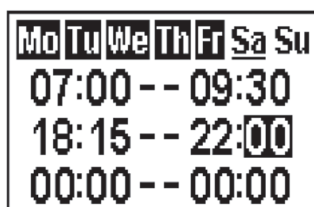

Press the '**→**' button to move the cursor to the time period setting area.

Press '**←**' or '**→**' button to choose hour or minute.

Press '**+**' or '**-**' to set the number.

A maximum of 3 timed heating periods can be set per day.
Minute increment / decrement by 15min per press.

Press **←** to set the heating time for the selected day and return to the week line.

Hold the **←** button for 3 seconds or wait for 10 seconds to save and exit the heating time period setting.

Press **←** '**←**' or '**→**' to check the timer setting for the week timer heating mode.

If the heating needs to be turned off, it will be necessary to go back to the Normal Control Mode to it turn off.

When in Weekly Timer Mode switching the appliance off with the remote will stop the light output. The heat output will continue according to the timer settings.

ADJUSTING THE SET TEMPERATURE

Press the '**+**' or '**-**' button to increase or decrease the temperature on the basis of COMF temperature.

COMF means the actual temperature is the same as setting.

ECO means the actual temperature is 2°C lower than the setting temperature.

ECO- means 4°C lower.

COMF+ means 2°C higher.

COMF++ means 4°C higher.

ADAPTIVE START CONTROL

According to room temperature and set-pointed temperature, the heater will automatically determine the appropriate time to heat to ensure that it will reach the set-pointed temperature in the set time (up to 45 minutes prior to the set time).

ADVANCE MODE

The heating state can be advanced to the next period is under both the daily and week timer heating mode.

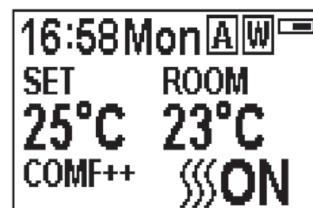

If the heater is on in the current period, pressing the button will turn the heater off.

If the heater is off in the current period, pressing the button will turn the heater on.

Whether the actual heating will be on/off also depends on the room temperature and setting temperature.

Press **W A** to enter the Advance mode under the daily and week timer heating mode, **A** will show at the upper right corner of the screen.

Press **W A** again or timer period ends will exit the Advance mode.

WINDOW OPEN DETECTING

When the transmitter detects a rapid drop in room temperature, it will be judged as an open window: the warning icon will be displayed and the heating will be turned off automatically.



After indoor temperature rise or manual intervention (by operating remote control), it will return to normal working state.

LOG EFFECT

The Log effect is a glass fibre fuel bed which may give off a slight smell when first used. This is normal and should disappear after a day or two.

FITTING FASCIAS

The electric Riva2 670 is designed to accept several different decorative fascias. For individual fixing methods refer to the fascia installation instructions.

When installing the Riva2 670 with a Wall Mounting Kit the addition of side mounting brackets are required before fitting the Evoke, Verve or Verve XS fascia. See Installation Section.

MAINTENANCE

ALWAYS UNPLUG FROM MAINS SUPPLY BEFORE CLEANING OR UNDERTAKING ANY MAINTENANCE.

GENERAL CLEANING

Only clean the outer casing when it is cold. Do not use abrasive cleaners.

CLEANING AIR INLETS

Ensure the appliance is unplugged.

Clean the air inlet (a) and outlet (b) grilles regularly with a soft cloth or the nozzle of a vacuum cleaner.

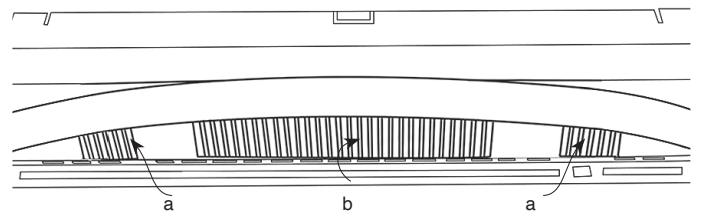

Dust build-up can inhibit efficient performance of the fan and lead to the safety cut-out operating.

Keep the area around the appliance clean and free of fluff, dust or pet hair.

In particular, build-up of dust etc. can occur around and under the heater area. Take particular care to keep this area free from such particles on a regular basis to prevent build-up.

BATTERY REPLACEMENT

When the remote battery is low it must be changed immediately. Install correct replacement and dispose of the old battery carefully at an appropriate recycling facility.

INSTALLATION INSTRUCTIONS

TECHNICAL SPECIFICATION

These instructions cover the following models:

ELECTRIC RIVA2 670
234-872AZ

A 220V-240V 10A 50Hz supply is required
Maximum power consumption:
2064 Watts

THIS APPLIANCE MUST BE EARTHED

A 1.8 metre lead with plug is supplied.*

Remote control handset batteries (2 x AAA).

* USE OF ALTERNATIVE POWER LEADS IS NOT RECOMMENDED AND MAY VOID WARRANTY.

If an alternative power lead is used care should be taken to ensure conductor size and connector type is suitable carrying continuous 10A load.

This appliance is compatible with the following fascias:

- Verve XS
- Designio2 Glass
- Designio2 Steel
- Evoke Glass

This appliance has been certified for use in countries other than those stated. To install this appliance in these countries, it is essential to obtain the translated instructions and in some cases the appliance will require modification. Contact Gazco for further information.

PACKING CHECKLIST

APPLIANCE DESCRIPTION	FIXING KIT CONTAINING:
Riva2 670 Electric	1 x Instruction Manual 4 x Screws 4 x Rawl plugs 1 x Handset 2 x Retention screws 2 x AAA Batteries

CONTROL SYSTEM TECHNICAL DATA - ALL MODELS

	MAIN CONTROL BOARD	REMOTE RECEIVER BOARD	REMOTE CONTROL
Hardware	RC01-040A04 V2	RF290B V1.2	RF290A-TX V1.3
Software	RC01-040A04 V2	-	RF290C V06.0.HEX
Frequency	-	-	ASK/OOK 433.92MHz
Maximum Transmit Power	-	-	10mW

FASCIA DIMENSIONS

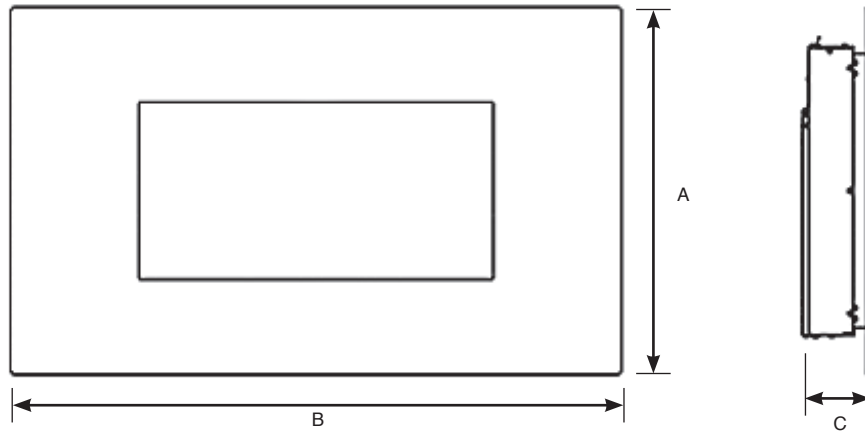

FASCIA	VERVE XS	DESIGNIO2 GLASS	DESIGNIO2 STEEL	EVOKE GLASS
A	621	569	569	622
B	1000	735	735	920
C	166	150	150	150

WALL HANGING KIT DIMENSIONS

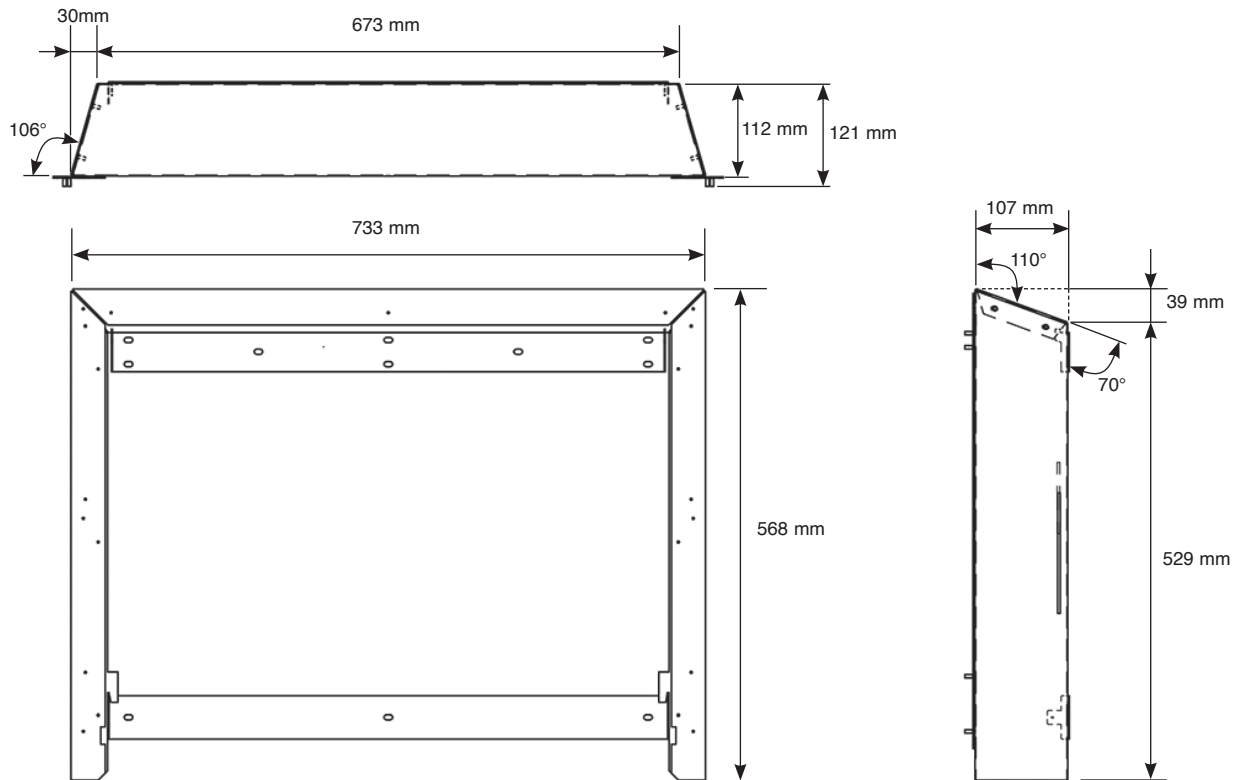

APPLIANCE DIMENSIONS

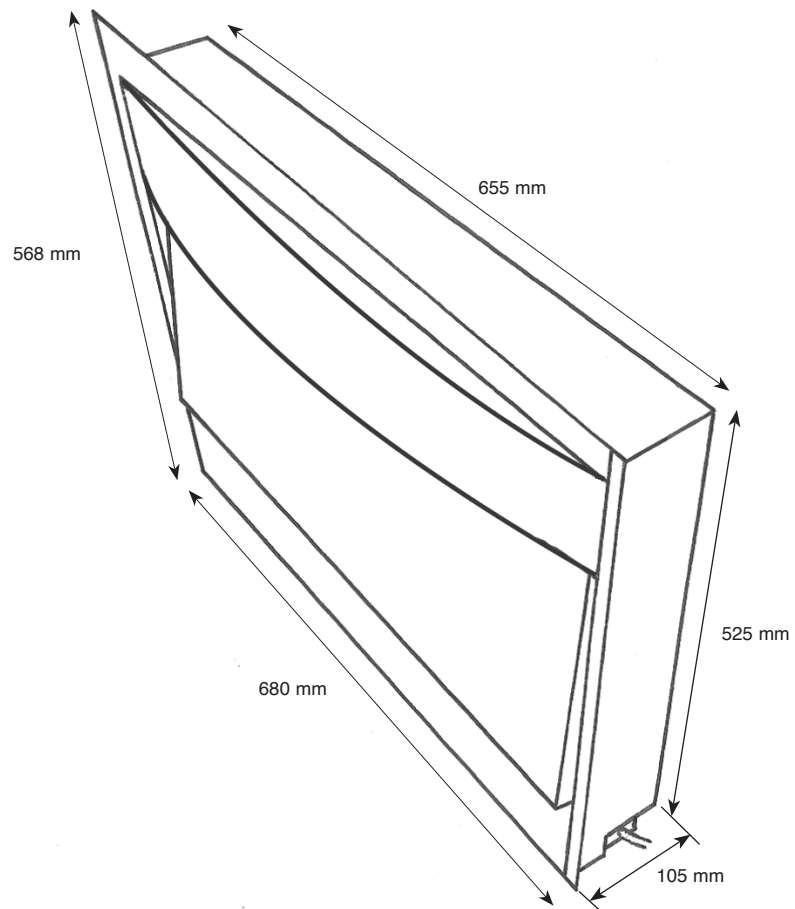

GENERAL

TOOLS REQUIRED

A Screw Driver, Spirit Level and Drill will be needed.

UNPACKING THE FIREPLACE

WARNING! DO NOT use this appliance if any part has been exposed to water.

Immediately call a suitably qualified person to inspect and to replace any part of the electrical system if necessary.

Open the packaging carefully and remove the polystyrene. Remove and discard the plastic bag. Keep plastic wrapping away from children. Be responsible when handling the packing materials.

Check all parts and accessories are removed before disposing of any packaging. If necessary keep the original packaging for future transport and/or storage.

FITTING THE APPLIANCE

LOCATING THE RIVA2 670 ELECTRIC

The Riva2 670 Electric may be installed virtually anywhere in your home. However, when choosing a location ensure that the general instructions are followed.

The heater should ideally be fitted into/onto an internal flat wall constructed from either studwork and plasterboard block/brick. The fixings provided are for use on brick walls ONLY. Please ensure that suitable fixings are used when securing to any hollow or purpose built cavity.

NOTE: This appliance is not suitable for fitting to a Cavity Wall, backing on to an outside wall, an open chimney or any opening that may be subject to damp and draft, unless adequate precautions are taken to avoid the appliance coming into contact with moisture or excessive drafts. In such installations, any existing chimney and/or purpose provided air vents should be fully sealed.

For best results, install out of direct sunlight.

If the power cord is damaged contact your Gazco retailer for a replacement. Only use genuine Gazco parts on this appliance.

The appliance should be located close to a suitable mains socket to enable connection.

The electrical socket must be easily accessible to allow disconnection when the appliance is fitted.

WARNING! KEEP ANY COMBUSTIBLE MATERIALS AT LEAST 1M FROM THE FRONT AND SIDES OF THE APPLIANCE.

This Riva2 670 can be installed using the following methods:

1. Recessed Installation - the appliance is located in a purpose built recess. See Diagram for the opening dimensions.

2. Wall Mounted - the appliance is hung on the wall using the optional Wall Mounting Kit (Part No. 8688SL).

If installing onto a hearth or non-combustible floor ensure a fascia which allows hearth mounting is used (Designio2). All other fascias require the appliance to be raised above floor height.

RECESSED INSTALLATION

Build the studwork chimney breast and enclosures to the desired size, see Diagram and table.

It is essential to include a header at the required height to ensure the appliance does not support the weight of the finished wall.

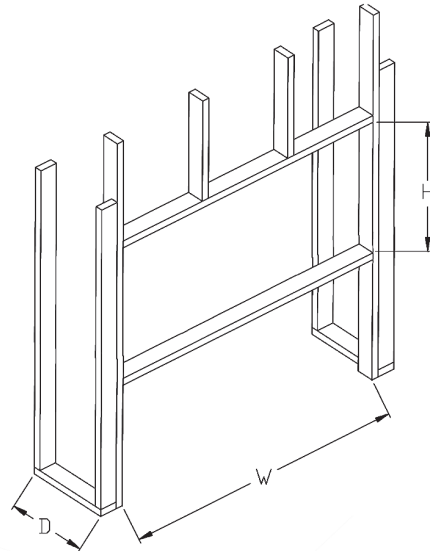

MODEL	W	D	H
Riva2 670	665mm	105mm	535mm

Decide on the height of the appliance ensuring the appliance is raised to a distance appropriate for the chosen fascia. For measurements refer to the fascia dimensions on page 10.

Prepare the recess opening according to the dimensions stated.

Offer the appliance into the recess and mark the position of the four fixing holes on the wall.

Drill the 4 holes and insert the rawlplugs provided. Note: The rawlplugs supplied are suitable for solid wall applications. If it is intended to mount the appliance onto plasterboard or hollow walls suitable fixings must be used.

Secure the appliance to the wall with the screws provided.

Fit the chosen fascia according to the instructions supplied.

WALL MOUNTED INSTALLATION



IMPORTANT Before fitting consider whether different wall fixing plugs need to be purchased to support the weight of the chosen frame on the intended type of wall.

Additional fixing holes may be required in the wall bars to strengthen the structure for heavier frames or studwork walls.

WALL BARS

The Top bar has a hook.
Lower bar has flange and screw hole, see Diagram.

Make sure there are no pipes or cables behind the area you drill.

Decide on the height of the appliance ensuring the appliance is raised to a distance appropriate for the chosen fascia.
For measurements refer to the fascia dimensions on page 10.

Position the Lower Fixing Bracket and mark the positions for the retaining screws. Remove the bracket and drill the holes.

Place the fixing plugs into the holes and secure the lower bracket using the screws provided.

Place the Upper Hook Bracket on the wall and mark the position ensuring that the distance between the bottom of each bracket is 425mm.

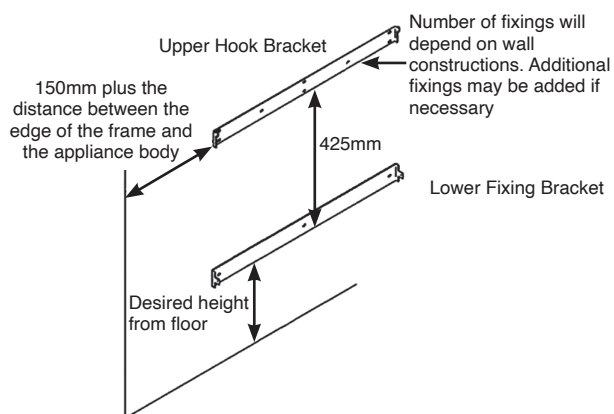

Use a spirit level to check the bars are straight. Mark the positions for the retaining screws. Remove the bracket and drill the holes.

Place the fixing plugs into the holes and secure the upper bracket using the screws provided.

FIRE BOX

Lower the 'fire box' onto the top wall bar hook so that the rear slot on the top of the fire locks over the hook.

Rotate the 'fire box' flat to the wall so that the flange in the lower bar fits with the bottom fire box slot.

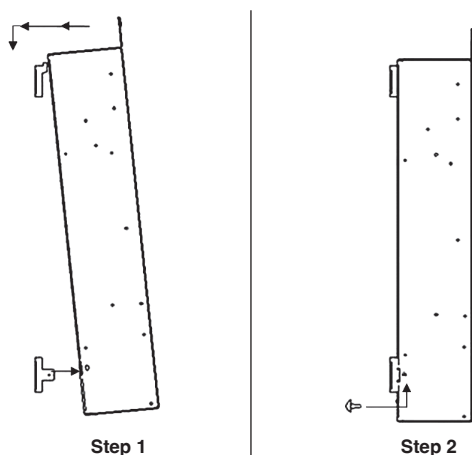

Use two No. 6 x 12 screws from the kit to fix the fire through both sides into the holes in the lower bar.



IMPORTANT: IT IS VITAL THAT THE APPLIANCE POWER SUPPLY IS CONNECTED TO THE PRODUCT AT THIS STAGE.

WALL BOX

Join the three pieces of wall box together.

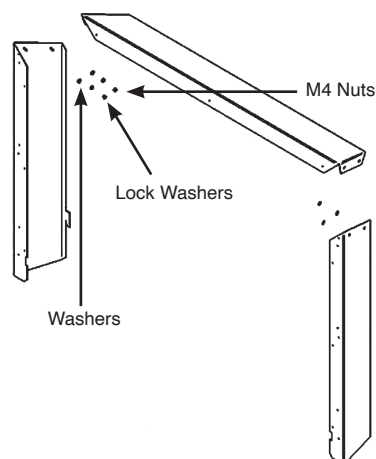

Insert threaded studs in the sides through the holes in the end flanges of the top.

Assemble the wall box using the washers, nut lock washers and M4 nuts supplied.

Before tightening, make sure the front face of the box structure is level.

Press face down onto a soft flat surface to protect from scratching or damage.

Now tighten the nuts.

With the appliance power supply in place:

— Slightly widen the legs of the wall box and lower it over the 'fire box' so its hooks clear the top wall bar.

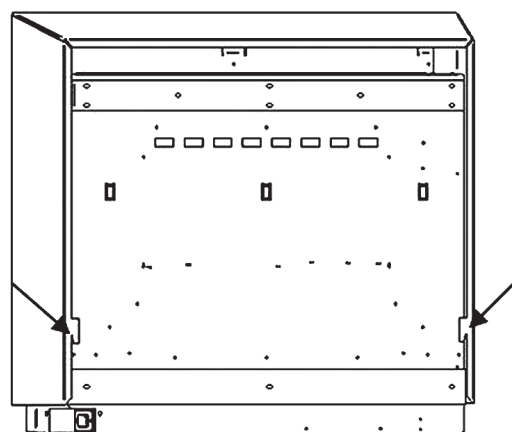

— Let the legs spring back once over the top bar to engaged with the lower bar.

INSTALLING WITH VERVE, VERVE XS AND EVOKE FRAMES

Fix the wall box to the appliance frame and the side brackets supplied with the frame using the 9 screws supplied.

Note: Lip of the appliance should sit in front of the wall box and the Side Bracket plates are fitted in front of the appliance. The Mounting Brackets for the frames can then be attached to the Side Bracket Plates.

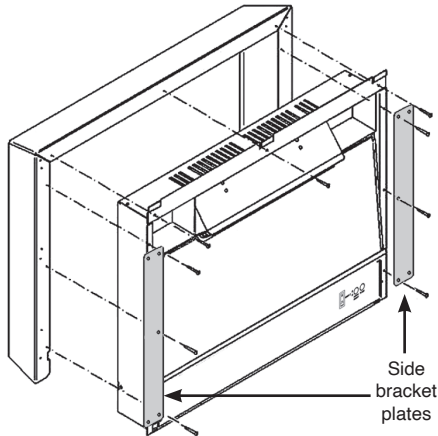

ALL OTHER FRAME TYPES

Fix the wall box to the appliance frame using the 9 screws supplied.

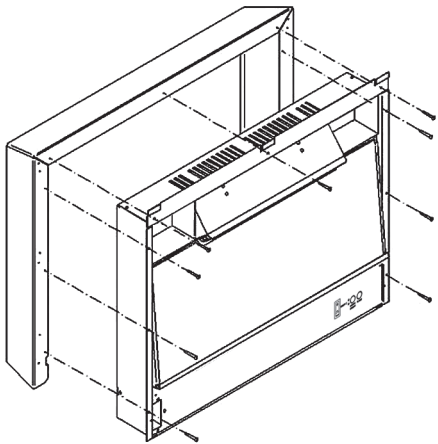

Complete the installation of the Electric Riva and the decorative frame by following the relevant instructions provided.

The appliance power cable can be hidden from view by either sinking it into the plaster of the wall behind a suitable conduit, or by running it through a surface mounted channel.

CARE & MAINTENANCE

Do not use abrasive cleaners on the wall box as this may damage the finish.

Use a lint-free damp cloth to wipe clean.

For the frame and appliance follow the instructions included with them.

FAULT FINDING

No illumination or uneven lighting:

First check the socket by plugging in a working appliance. If this too fails to operate, call in a competent electrician to check the socket.

One or more of the LED boards will need replacing. This must be undertaken by a suitably qualified person (see *Servicing Requirements*).

Illumination but no heat:

The safety cutout has operated to protect against overheating (see *User Instructions*). Ensure the air inlet and outlet grilles are free of dust or any other obstruction.

The thermostat control dial may be set too low. Turn the dial clockwise until the heater turns on.

Remote control fails to work:

Check that the batteries are new and correctly fitted. Replace if necessary.

SERVICING REQUIREMENTS

THIS APPLIANCE MUST ONLY BE SERVICED BY A SUITABLY QUALIFIED PERSON.

**BEFORE UNDERTAKING ANY WORK ON THE APPLIANCE:
SWITCH OFF THE APPLIANCE AND ISOLATE IT FROM THE
MAINS BY UNPLUGGING THE UNIT.**

Wait for at least 10 minutes until the appliance has cooled down.

Remote Handset Battery Replacement

Replace the batteries (2 x AAA). Make sure the batteries are installed correctly in the remote control.

Maintenance of Motors

The motors used on the fan and flame effect are pre-lubricated for extended bearing life and require no further lubrication. However, periodic cleaning/vacuuming of the fan/heater unit is recommended.

Resetting the Thermal Cutout Switch

The appliance is fitted with an Electronic Safety Control (E.S.). This is a safety device which switches off the fire if, the appliance overheats for any reason e.g. when covered.

If the heater stops operating whilst the flame effect continues normally, this indicates that the E.S. Control is in operation.

The E.S. Control can only be re-set after the appliance has cooled down.

To re-set the E.S:

Switch off the appliance (Manual On/Off switch) and leave for approximately 120 minutes.

Remove any obstruction to the fan heater outlet or other internal parts.

Switch on appliance and the E.S. Control will re-set. Ensure that the appliance is functioning correctly. If the E.S. Control operates again, the appliance should be checked by a suitably qualified person.

REMOVING THE SCREEN

Isolate the power supply and ensure there is no power to the appliance.

Remove the 2 screws and lift the bracket away from the screen.

Note: When replacing the bracket there is a flange that hooks over the top of the glass to hold the screen in place.

Pull the glass forward and lift out of the channel.

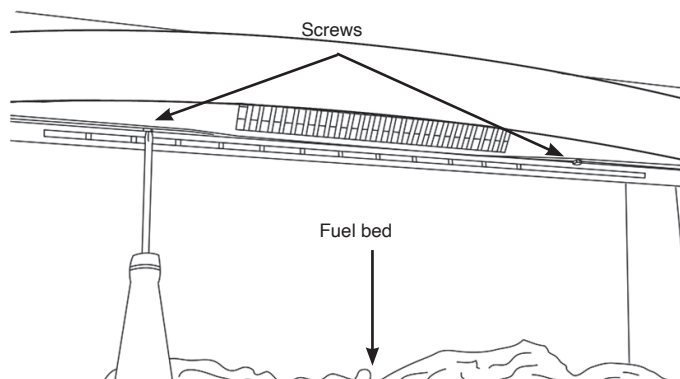

REMOVING THE FUEL BED

Remove the screen.

Remove the 2 screws on either side of the appliance.

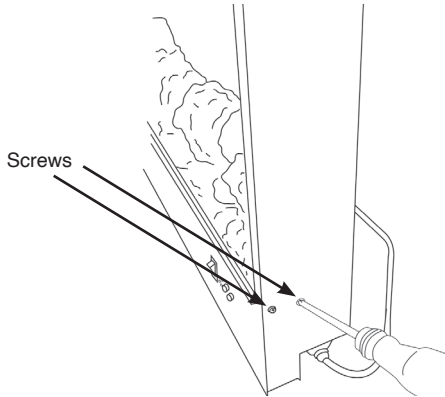

Remove the 4 screws on the back (2 on either side of the back).

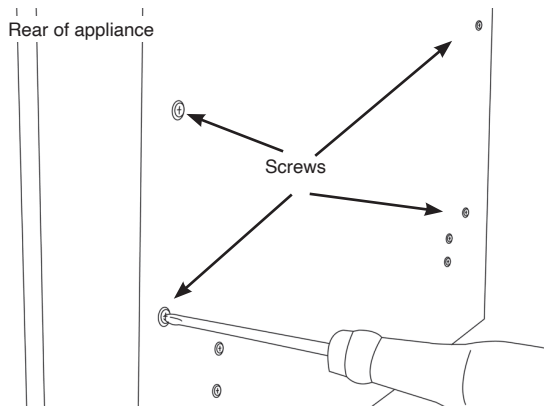

Remove the 2 side covers by carefully sliding forward.

Lift the fuel bed carefully out through the front of the appliance.

Ensure the rubber sleeve from the bottom of the screen does not fall into the firebox.

REMOVING THE FRONT PANEL

Isolate the power supply and ensure there is no power to the appliance.

Lay the appliance on its back on a flat surface.

Remove the bottom front panel by removing the 2 screws from the right side, 2 from the left side and 3 from the bottom of the appliance.

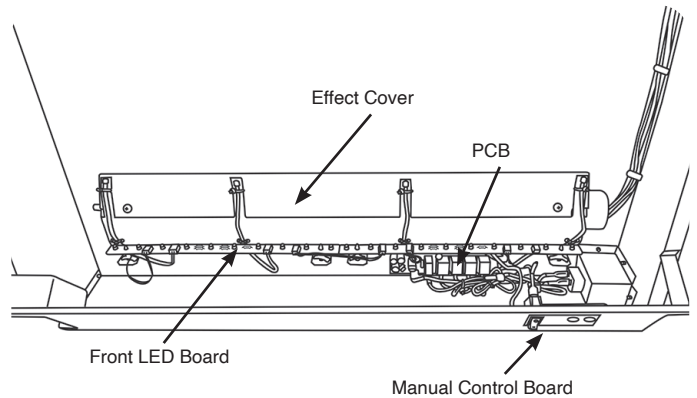

It is now possible to access all components.

REPLACING THE EFFECT ENGINE

Remove the screen and fuel bed.

It is advisable to remove the bottom front panel to access the effect engine.

Remove the 4 screws on the back of the appliance.

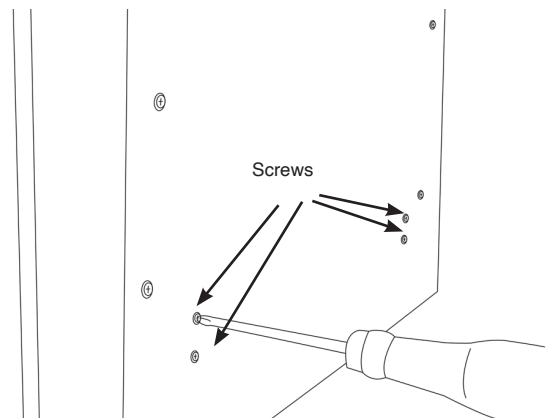

Unplug the LED boards and wires. Cut the cable ties.

Replace in reverse order ensuring the wires are put back in exactly the same configuration.

REPLACING THE LED BOARDS

Remove the screen.

It is advisable to remove the bottom front panel to access the effect engine.

FRONT LED BOARD

Unplug the wire connected to the LED board.

Using a pair of long nosed pliers remove the board from the plastic pegs securing it to the appliance.

Replace in reverse order.

REAR LED BOARD

Remove the 2 screws on either side of the LED board.

Remove the 3 screws securing the rear LED board to the appliance.

Replace in reverse order.

Dispose of any old boards at an appropriate recycling centre.

REPLACING THE HEATER ASSEMBLY

Refer to Section 4 to remove the screen.

REMOVE THE HEATER COVER

Remove the 4 screws, 2 on either side of the top of the appliance

Remove 3 screws closest to the front on top of the appliance.

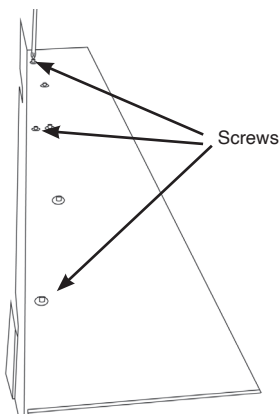

REMOVE THE HEATER ASSEMBLY

Remove the 3 screws towards the rear of the top of the appliance.

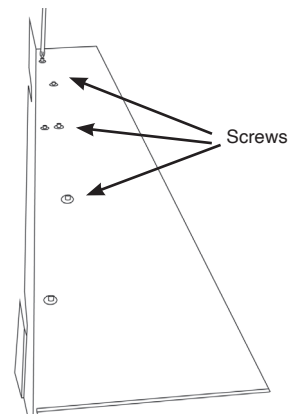

Remove the 3 screws at the top of the back of the appliance. **SUPPORT THE HEATER ASSEMBLY WHILST REMOVING THE SCREWS.**

Undo 4 screws to remove the fan heater assembly.

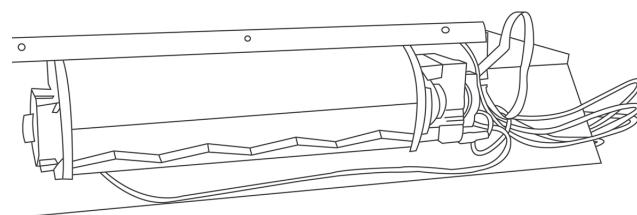
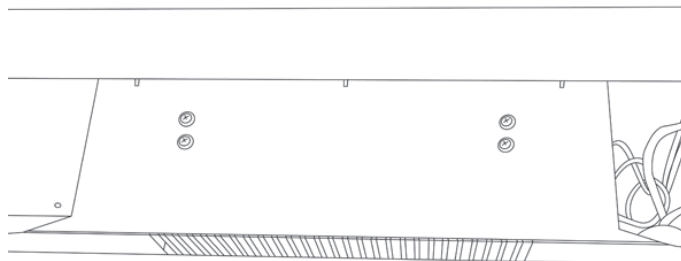

Replace in reverse order ensuring the wires are put back in exactly the same configuration.

REPLACING THE RF RECEIVER

Remove the screen

Undo the screw securing the RF Receiver.

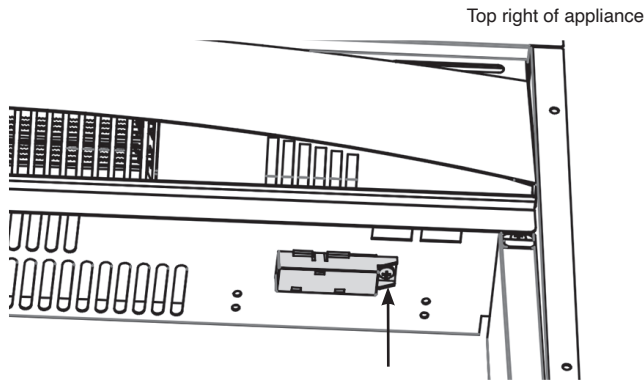

Slide the RF Receiver right and lower out of its location.

Remove the PCB.

Disconnect to remove.

Replace in reverse order.

REPLACING THE PCB UNIT

Remove the screen and fuel bed.

Lay the appliance on its back on a flat surface.

Remove the bottom front panel.

Remove the 2 screws and using a pair of long nosed pliers squeeze the clips that hold the PCB to the appliance in order to release.

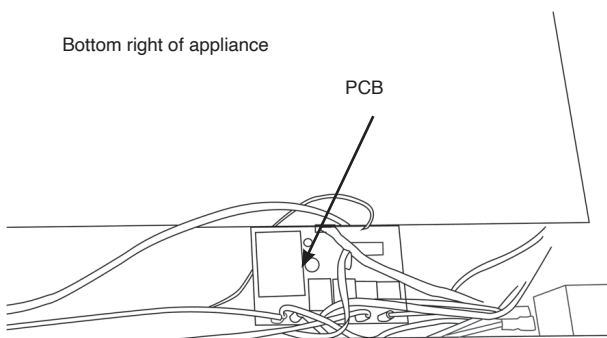

IMPORTANT: Make note of the wiring positions before removing any connections.

Replace in reverse order ensuring the connections are put back in exactly the same configuration as was originally found.

REPLACING THE MANUAL CONTROL BOARD

Remove the screen and fuel bed.

Lay the appliance on its back on a flat surface.

Remove the bottom front panel.

Undo the 2 screws and unclip the connector to remove the board.

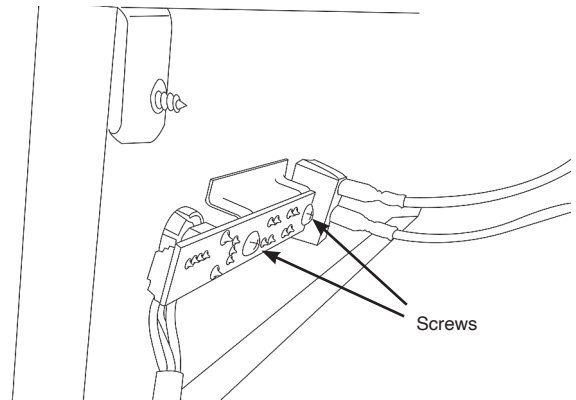

Replace in reverse order ensuring the wires and connectors are put back in exactly the same configuration.

PAIRING THE REMOTE CONTROL TO THE APPLIANCE

Signal Code

The below operations should be carried out before coding when changing to a new remote or the unit cannot be controlled by the remote:

The reset button is located on the control panel located on the right-hand side of the viewing window, see Diagram 13.

Press the reset button for 3 seconds (a pen point may be needed) until 3 short beeps sound from the unit, release the button.

Within 10 seconds, press the button on remote. The coding is finished when 1 long beep sounds from the unit.

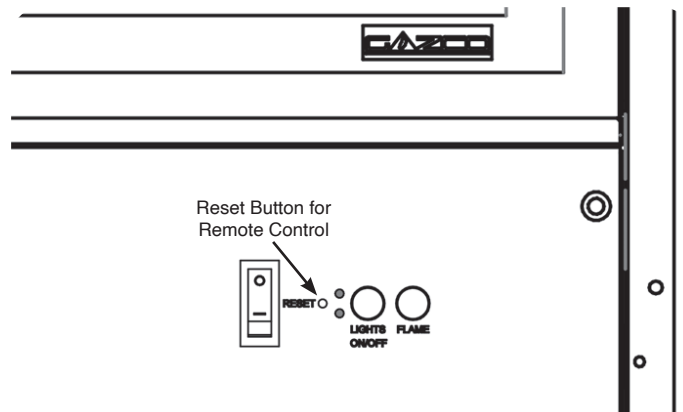

Resetting of the remote control is necessary if the appliance operates wrongly due to external interference signal and the remote control is not in use.

RESETTING THE REMOTE

Resetting the Remote may necessary if the appliance operates incorrectly under the signal from the Remote, or if the Remote does not operate correctly.

Open the back cover of the Remote.

Press the Reset button for 3 seconds and reset the coding.



WIRING DIAGRAM

All Models

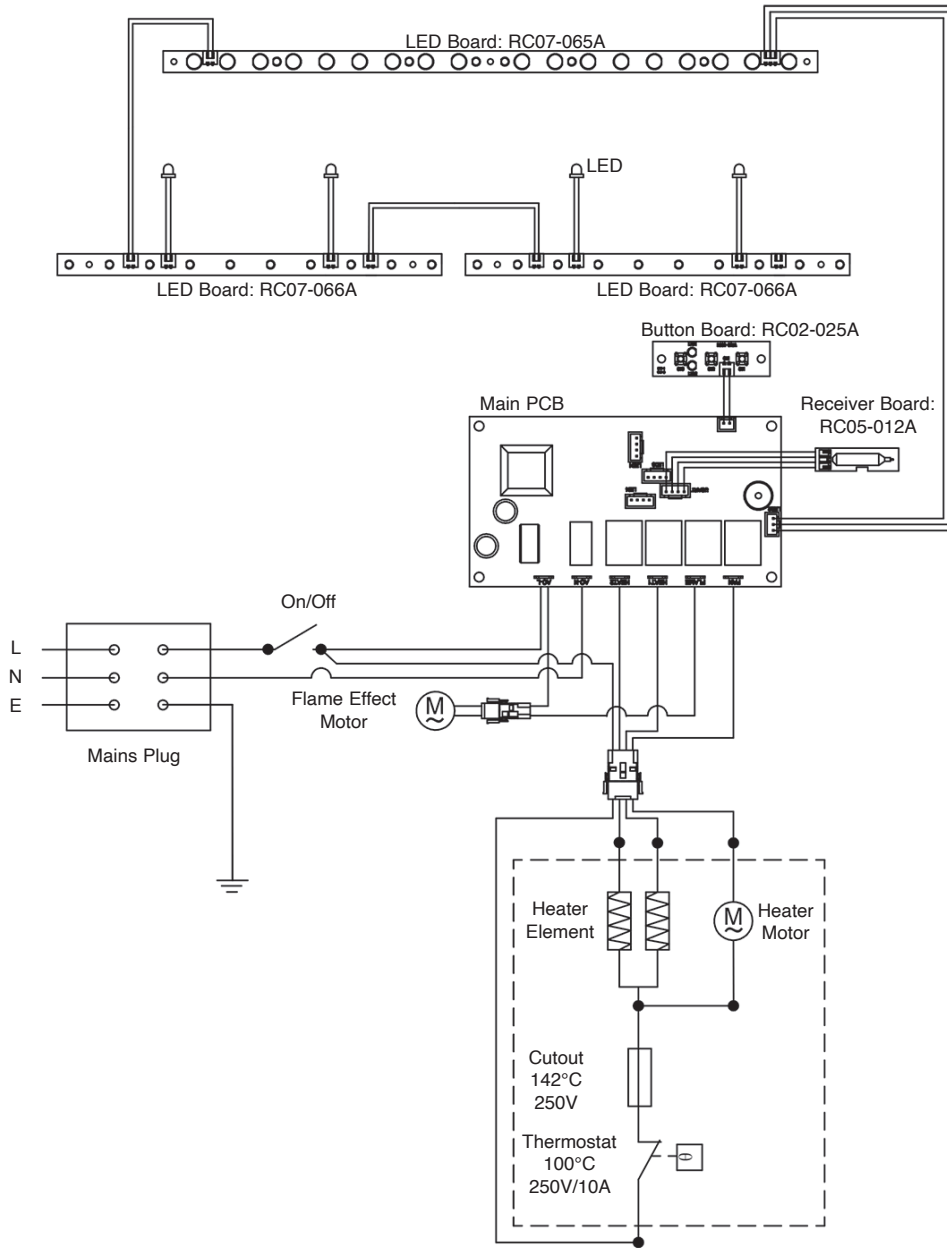

SPARES LIST - MAIN ASSEMBLY

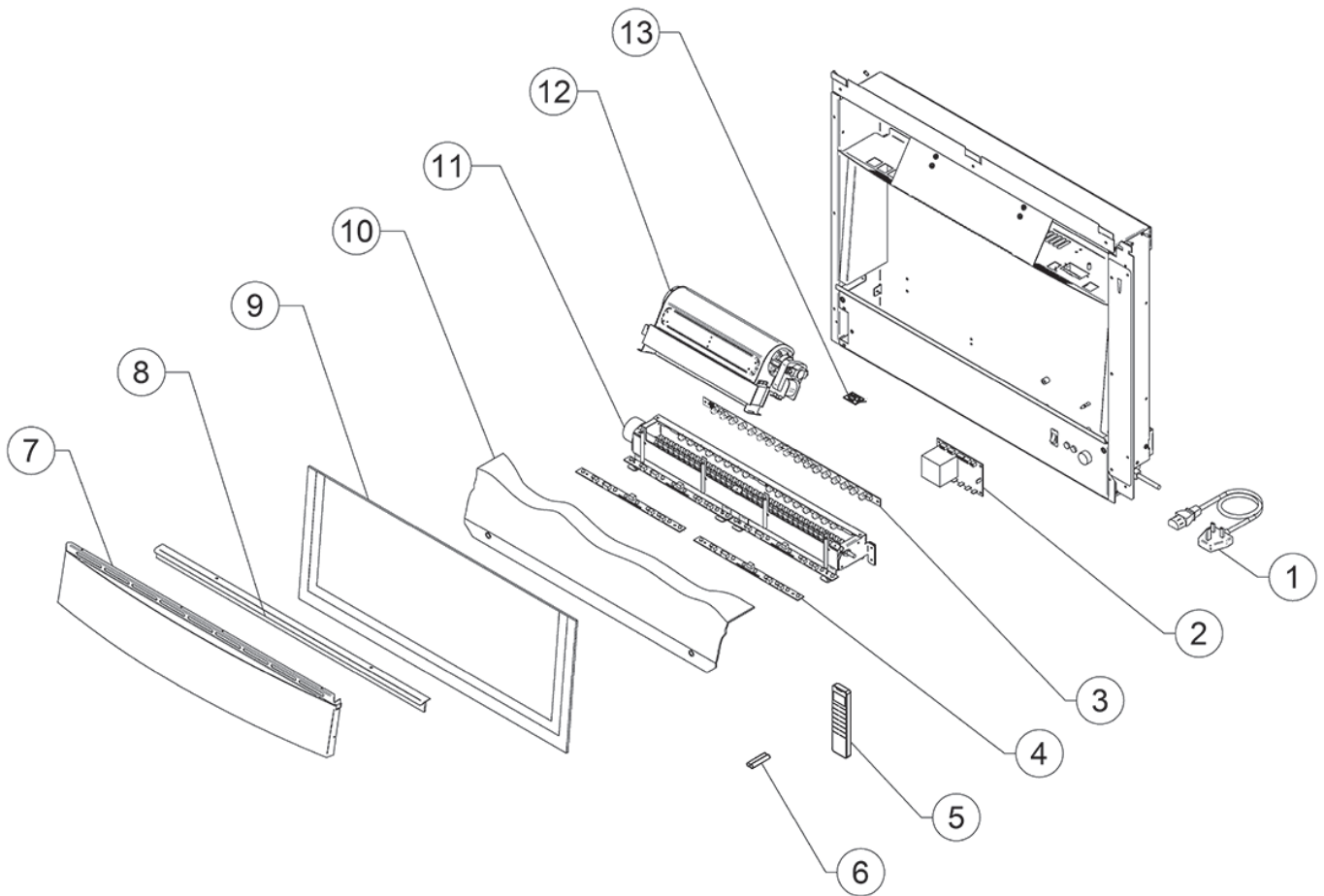

NO	COMPONENT	PART CODE	QUANTITY
1	Power Cable - Straight	EL0548	1
2	Main PCB Unit	EL0741	1
3	Rear LED Board	EL0742	1
4	Front LED Board	EL0494	2
5	Remote Handset D	EL0679	1
6	Remote Battery (1.5 V, AAA)	N/A	2
7	Heater Cover	GZ10607	1
8	Top Glass Clamp	GZ9942	1
9	Main Front Screen	CE1244	1
10	Log Fuel Effect	CE1138	1
11	Motor & Effect Assembly	GZ9945	1
12	Heater Assembly	EL0558	1
13	RF Receiver Board	EL0735	1



Due to continual technical improvements please check online or with your Gazco retailer for the most up to date parts lists.

Only use Genuine Gazco spares when servicing your appliance.

All of our essential spare parts and consumable items are available to purchase from our webshop at www.gazcospares.com.

WARRANTY

LIMITED WARRANTY

This product comes with an extended Limited Warranty to the original purchaser of this appliance provided the product remains in the original place of installation.

Some conditions apply (see below).

The policy is not transferable, amendable or negotiable under any circumstances.

After the original warranty coverage has expired, any repair and/or replacement parts purchased by the consumer through an accredited distributor or dealer will carry a ninety (90) day warranty (valid only with an original copy of the tax invoice). No labor coverage is included with any repair and/or replacement part.

Replacement parts are limited to one per warranty term.

Conditions:

Warranty protects against defect in manufacture or factory assembled components only, unless herein specified otherwise. This warranty will only apply to those products which are acquired at the time of this warranty being effective. Excluding liability for any damage or loss that falls outside the scope of the warranty.

Any part(s) found to be defective during the warranty period as outlined above will be repaired or replaced at the discretion of our accredited distributor, dealer or pre-approved and assigned agent provided that the defective part is returned to the distributor, dealer or agent for inspection if requested. Alternatively, the supplier may at its own discretion fully discharge all of its obligations under the warranty by refunding the verified purchase price of the product to the original purchaser. The purchase price must be confirmed by an original copy of the tax invoice.

The authorised selling dealer, or an alternative authorised dealer if pre-approved by the supplier, is responsible for all in-field diagnosis and service work related to all warranty claims. This warranty does not cover dealer travel costs for diagnostic or service work. Dealers may charge homeowner for travel and additional time. Check with your selling dealer in advance for any costs to you when arranging a warranty call. The supplier is not responsible for results or costs of workmanship of unauthorised dealers or agents in the negligence of their service work. Additional service fees may apply if you are seeking warranty service from a dealer other than the dealer from whom you originally purchased the product.

At all times the supplier reserves the right to inspect reported complaints on location in the field claimed to be defective and determine whether the warranty will apply prior to processing or authorising of any claim. Failure to allow this upon request will void the warranty.

All warranty claims must be submitted by the dealer servicing the claim, including an original copy of the tax invoice (proof of purchase by you). All claims must be complete and provide full details as requested to receive consideration for evaluation, including proof of maintenance records. Incomplete claims may be rejected. The supplier has absolute discretion to assess and determine any warranty claim and may accept or reject a claim as it considers appropriate. Any part or parts of the unit found to be defective will be repaired or replaced at the option of the supplier, through an accredited distributor or service agent provided that the defective part be returned to the distributor or agent, Transportation Prepaid, if requested. It is the general practice to charge for larger, higher priced replacement parts and issue credit once the replaced component has been returned and evaluated for manufacturer defect.

If a consumer has a unit installed outside an accredited distributor, dealer or pre-approved service agent's service area, or the closest approved service agent is situated more than thirty (30) kilometres from the installation, the supplier is not obliged to arrange warranty repairs or shipping/transportation costs. In these cases, the consumer must arrange warranty service with its selling dealer, and shipping, travel and/or additional labour charges will apply.

Unit must be installed according to all manufacturers' instructions as per the manual.

All Local and National required codes must be met.

The installer is responsible to ensure the unit is operating as designed at the time of installation.

The original purchaser is responsible for annual maintenance of the unit, as outlined in the owner's manual. As outlined below, the warranty may be voided due to problems caused by lack of maintenance. Annual maintenance records should be retained.

WARRANTY

EXCLUSIONS

This Limited Warranty does not extend to paint, rust or corrosion of any kind due to a lack of maintenance or improper venting, combustion air provision, corrosive chemicals (i.e. chlorine, salt, air, etc.), firebrick (rear, sides or bottom), door or glass gasket, or any other additional factory fitted gasket.

Malfunction, damage or performance based issues as a result of environmental conditions, location, chemical damages, downdrafts, installation error, installation by an unqualified installer, incorrect chimney components (including but not limited to cap size or type), operator error, abuse, misuse, use of improper fuels (such as unseasoned timber, mill-ends, construction timber or debris, off-cuts, treated or painted timber, tea tree, metal or foil, plastics, garbage, solvents, cardboard, coal or coal products, oil based products, waxed cartons, compressed pre-manufactured logs), accidents, lack of regular maintenance and upkeep, acts of God, weather related problems from hurricanes, tornados, earthquakes, floods, lightning strikes/bolts or acts of terrorism or war, which result in malfunction of the appliance are not covered under the terms of this Limited Warranty.

The supplier has no obligation to enhance or modify any unit once manufactured (i.e. as products evolve, field modifications or upgrades will not be performed on existing appliances).

Any unit showing signs of neglect or misuse will not be covered under the terms of this warranty policy and may void this warranty. This includes units with rusted or corroded fireboxes which have not been reported as rusted or corroded within three (3) months of installation/purchase. Any alteration to the unit which causes sooting or carboning that results in damage to the exterior fascia or over firing that can cause component or firebox/heat exchanger failure will not be covered by this warranty.

Units which show evidence of being operated while damaged, or with problems known to the purchaser and causing further damages will void this warranty.

Units where the serial no. has been altered, deleted, removed or made illegible will void this warranty.

Minor movement, expansion and contraction of the steel is normal and is not covered under the terms of this warranty.

Freight damages for products or parts are not covered under the terms of the warranty.

Porcelain/Enamel: Absolute perfection is neither guaranteed nor commercially possible. Any chips must be reported and inspected by the authorised selling dealer within three (3) days of installation. Any damage of this type not reported after this time period will be subject to rejection and any related warranty will not apply.

Special Finishes: Expect some changes in color as the product "ages" with constant heating and cooling. The manufacturer warranty does not cover tarnishing, changing colors and/or marks (i.e. finger prints, etc.) after the purchase of the product. Damage from the use of abrasive cleaners is not covered by warranty.

Products made or provided by other manufacturers and used in conjunction with the appliance may void this warranty.

INCORRECT INSTALLATION IS NOT COVERED BY WARRANTY. A SERVICE OR CALLOUT FEE WILL BE CHARGED IN THESE CIRCUMSTANCES.

WARRANTY

LIMITATIONS OF LIABILITY

1. Exclusion of implied terms

The customer may have the benefit of consumer guarantees under the Consumer Law. To the maximum extent permitted by law, all terms, conditions or warranties that would be implied into this Warranty or in connection with the supply of any goods or services by the supplier under law or statute or custom or international conventions are excluded.

2. Limitation of liability

(a) To the maximum extent permitted by law and subject to clause 1, the supplier's total liability arising out of or in connection with its performance or its obligations pursuant to this Warranty, or arising out of or in connection with the supply of specific goods or services (including pursuant to or for breach of this Warranty, under statute, in equity or for tort, including negligent acts or omissions) is limited as follows: (i) the supplier shall have no liability to the customer for any Consequential Loss; (ii) without limiting the effect of clause 2(a)(i), the supplier's total aggregate liability for Loss, however arising, shall not exceed the GST exclusive aggregate price paid by the customer to the supplier for the specific goods or services that gave rise to the Loss in question.

(b) The limitations and exclusions in this sub-clause do not apply to the extent that any Loss is directly attributable to: (i) the personal injury or death caused by the supplier's default, breach of this Warranty or negligence; or (ii) fraud by the supplier.

(c) Each party must take reasonable steps to mitigate any Loss it suffers or incurs. .

3. Subject to Change

This Limited Warranty is given at the time of sale and purchase of the relevant fireplace product. The terms of this Limited Warranty may be amended from time to time in accordance with changes to business practices, consumer laws or other legal requirements. The rights and protections granted under the Limited Warranty are those in force in relation to a fireplace product at the time and in the place of sale of that product, and only those terms will be applicable in respect of that product.

4. Severability

Any term of this Limited Warranty that is invalid or unenforceable in any jurisdiction is to be read down for the purposes of that jurisdiction, if possible, so as to be valid and enforceable, and is otherwise capable of being severed to the extent of the invalidity or unenforceability, without affecting the remaining provisions of this Limited Warranty or affecting the validity or enforceability of that provision in any other jurisdiction.

5. Definitions

For purposes of clauses 1 and 2:

(a) Consequential Loss means loss of expected savings, loss of use, loss of opportunity, loss of profit, loss of revenue, increased financing costs, loss arising from delay, or any consequential, special or indirect loss or damage, whether or not the possibility or potential extent of the loss or damage was known or foreseeable, and whether arising from a claim under indemnity, contract, tort (including negligence), statute or otherwise.

(b) Loss means any expense, cost or damage of any kind and includes Consequential Loss and a fine or penalty imposed by a statutory or other authority.

Distributed by:

Australia

Fireplace Products Australia Pty Ltd
99 Colemans Road
Dandenong, South VIC, 3175
AUSTRALIA
+613 9799 7277
www.regency-fire.com.au

New Zealand



Head Office & Showroom
12 Tawari Street
Mt Eden, Auckland, New Zealand
+649 623 6990
thefireplace.co.nz

Manufactured by

Gazco Limited, Spitfire Avenue, Skypark, Clyst Honiton, Exeter, Devon, England EX5 2FR

Tel: (01392) 261900 E-mail: info@gazco.com

Technical Customer Services (01392) 261950 Fax: (01392) 261951

E-mail: technicalservices@gazco.com

A member of the Stovax Group

E & O E



PR2477AZ