



Regency Horizon® HZO42 Outdoor Gas Fireplace

Owners & Installation Manual

MODELS: HZO42-NG11
HZO42-LP11



www.regency-fire.com

HZO42 Product Video

⚠ WARNING:

If the information in these instructions are not followed exactly, a fire or explosion may result causing property damage, personal injury or loss of life.

⚠ WARNING: For Outdoor Use Only.

Installation and service must be performed by a qualified installer, service agency, or the gas supplier.

⚠ DANGER - FIRE OR EXPLOSION HAZARD

If you smell gas:

- Shut off gas to the appliance.
- Extinguish any open flame.
- If odour continues, leave the area immediately.
- After leaving the area, call your gas supplier or fire department.

Failure to follow these instructions could result in fire or explosion, which could cause property damage, personal injury, or death.

WARNING:

Do not store or use gasoline, or other flammable vapors and liquids, in the vicinity of this or any other appliance.

An LP-cylinder not connected for use shall not be stored in the vicinity of this or any other appliance.

Tested by:



Installer: Leave this manual with the appliance.
Consumer: Retain this manual for future reference.

To the New Owner:

Congratulations!

You are the owner of a state-of-the-art Gas Fireplace by Regency®. The Regency Horizon® HZO42 Outdoor fireplace has been designed to provide you with all the warmth and charm of a fire at the flick of a switch. The Regency Horizon® HZO42 Outdoor fireplace has been approved by Warnock Hersey/Intertek for both safety and efficiency. As it also bears our own mark, it promises to provide you with economy, comfort and security for many trouble free years to follow. Please take a moment now to acquaint yourself with these instructions and the many features of your Regency® Fireplace.



DANGER

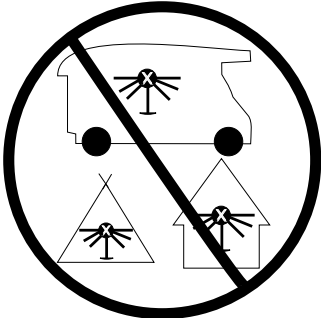

CARBON MONOXIDE HAZARD
 This appliance can produce carbon monoxide which has no odor.
 Using it in an enclosed space can kill you.
 Never use this appliance in an enclosed space such as a camper, tent, car or home.

MONOXYDE DE CARBONE
 Cet appareil peut produire du monoxyde de carbone, un gaz inodore.
 L'utilisation de cet appareil dans des espaces clos peut entraîner la mort.
 Ne jamais utiliser cet appareil dans un espace clos comme un véhicule de camping, une tente, une automobile ou une maison.

919-780a



WARNING!



**HOT GLASS WILL
CAUSE BURNS**

**DO NOT TOUCH GLASS
UNTIL COOLED**

**NEVER ALLOW CHILDREN
TO TOUCH GLASS**



Horizon HZO42 Product Video

⚠ WARNING:

Improper installation, adjustment, alteration, service or maintenance can cause injury or property damage. Read the installation, operating and maintenance instructions thoroughly before installing or servicing this equipment.



www.nficertified.org

We recommend that our products be installed and serviced by professionals who are certified in the U.S. by the National Fireplace Institute® (NFI) or in Canada by Wood Energy Technical Training (WETT).



safety label

Copy of Safety Decal4
 Decal Location4

dimensions

Unit Dimensions5

installation

Gas Installation Checklist6
 Important Message8
 Before You Start.....8
 General Safety Information8
 Installation Checklist.....9
 Locating Your Gas Fireplace9
 Outdoor Appliance Installation Summary..... 10
 Minimum Clearances to Combustibles 11
 Framing Dimensions 12
 Mantel Clearances 13
 Non Combustible Requirements..... 13
 HZO42 Enclosure Vent Installation..... 14
 Finishing..... 15
 High Elevation..... 16
 Gas Line Installation 16
 Pilot Adjustment..... 16
 Gas Pipe Pressure Testing 16
 880 S.I.T. Valve Description..... 16
 Aeration Adjustment..... 16
 Unit Assembly Prior to Installation 17
 Standoff Assembly..... 17
 Nailing Strips 17

Drain Installation (recommended) 18
 Wall Switch and Battery Installation..... 19
 Wiring Diagram 20
 Hardwire Kit Installation 21
 AC Adaptor Installation 25
 Inner Panel Installation..... 26
 Glass Crystal Installation 27
 Volcanic Stone Installation 28
 Optional Log Set Installation 29
 Heat Deflector Installation 31
 Faceplate Installation..... 32
 Glass Wind Shield Installation..... 33
 Weather Cover Installation / Removal 33

operation

Operating Instructions 38
 Lighting Procedure 38
 Shutdown Procedure 38
 First Fire..... 38
 Aeration Adjustment..... 38
 Copy of Lighting Plate Instructions 39

maintenance

Maintenance Instructions 40
 Valve Assembly Replacement 41
 Digital Fireplace Burner Control removal..... 43
 Gas Maintenance..... 44

parts

Main Assembly 45
 Burner Assembly 46
 Accessories..... 47

warranty

Warranty 48
 Recycling 54

This is a copy of the label that accompanies each HZO42 Outdoor Fireplace. We have printed a copy of the contents here for your review.

NOTE: Regency® units are constantly being improved. Check the label on the unit and if there is a difference, the label on the unit is the correct one.

COPY OF SAFETY DECAL

Duplicate S/N 554

554

Minimum Clearances to Combustibles /
Dégagements min. aux matériaux combustibles /
Side Walls / Parois latérales

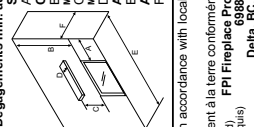

A Ceiling / Plafond 11" (279mm)
B Mantel Height / Hauteur de la cheminée 36" (914mm)
C Max. Mantel Depth / Prof. max. manteau 18" (457mm)
D Max. Mantel Depth / Prof. max. manteau 12" (305mm)
E Alcove Width / Largeur de l'alcove 57" (1448mm)
F Alcove Depth / Prof. alcove 36" (914mm)

Minimum Clearances to Combustibles /
Dégagements min. aux matériaux combustibles /
Side Walls / Parois latérales

A Ceiling / Plafond 11" (279mm)
B Mantel Height / Hauteur de la cheminée 36" (914mm)
C Max. Mantel Depth / Prof. max. manteau 18" (457mm)
D Max. Mantel Depth / Prof. max. manteau 12" (305mm)
E Alcove Width / Largeur de l'alcove 57" (1448mm)
F Alcove Depth / Prof. alcove 36" (914mm)

REGENCY
FIREPLACE PRODUCT

DO NOT REMOVE THIS LABEL / NE PAS ENLEVER CETTE ÉTIQUETTE
Serial No. / No. de série

APPAREIL FONCTIONNANT AU PROPANE
Modèle HZO42-LP11

Maximum supply pressure 14" WC/C.E. (3.49 kPa)
Minimum supply pressure 11" WC/C.E. (2.74 kPa)
Manifold pressure high 10" WC/C.E. (2.49 kPa)
Orifice size #47 DMS
Maximum input 43,500 Btu/h (12.74 kW)
Altitude 0-4500 ft. (0-1372 m)

APPAREIL FONCTIONNANT AU GAZ NATUREL
Modèle HZO42-NG11

Maximum supply pressure 14" WC/C.E. (3.49 kPa)
Minimum supply pressure 9" WC/C.E. (1.25 kPa)
Manifold pressure high 9" WC/C.E. (0.87 kPa)
Orifice size #29 DMS
Maximum input 44,500 Btu/h (13.04 kW)
Altitude 0-4500 ft. (0-1372 m)

FOR OUTDOOR USE ONLY / POUR UTILISATION À L'EXTÉRIEUR SEULEMENT
IF STORED INDOORS, DETACH AND LEAVE CYLINDER OUTDOORS, / SI STOCKÉ À L'INTÉRIEUR, DÉTACHER LA BOUTEILLE ET LA LAISSER À L'EXTÉRIEUR.

NOT FOR USE WITH SOLID FUELS / NE PAS UTILISER AVEC DES BOIS

For the State of Massachusetts, installation and repair must be done by a plumber or gas fitter licensed in the Commonwealth of Massachusetts.

For the State of Massachusetts, flexible connectors shall not exceed 36 inches in length.

For the State of Massachusetts, the appliances individual manual shut-off must be a t-handle type valve.

HZO42 DECAL LOCATION

- 1) Remove stainless steel 4-sided surround (not shown).
- 2) Remove both barrier glass. See below.

2 x Barrier Glass

- 3) Remove 3/4" (19 mm) stainless steel trim. See below.

Remove 3/4" (19 mm) trim

- 4) Lift up on the stainless-steel burner tray cover in front so the lighting plate and serial # decal may be pulled out.

Stainless Steel Burner Tray

- 5) Reverse steps to put back into place.

4 | Regency Horizon® HZO42 Gas Fireplace

UNIT DIMENSIONS

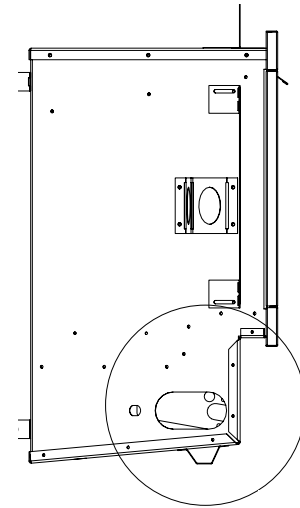
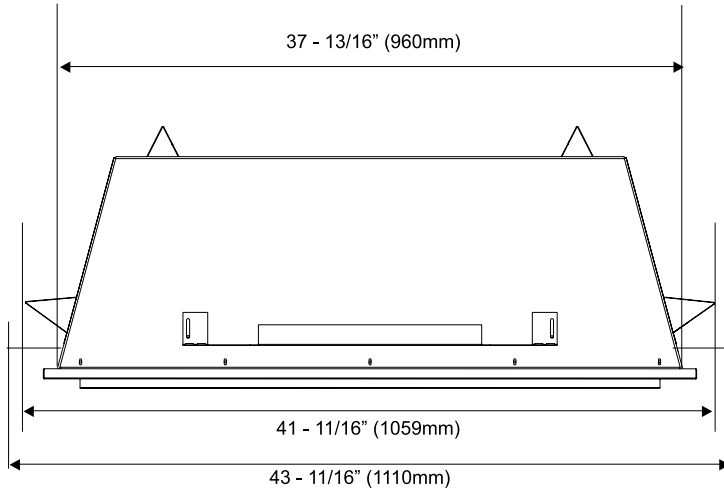

Note: Gas Connection/Electrical connections if using optional Hardwire Kit are located on left hand side of appliance.

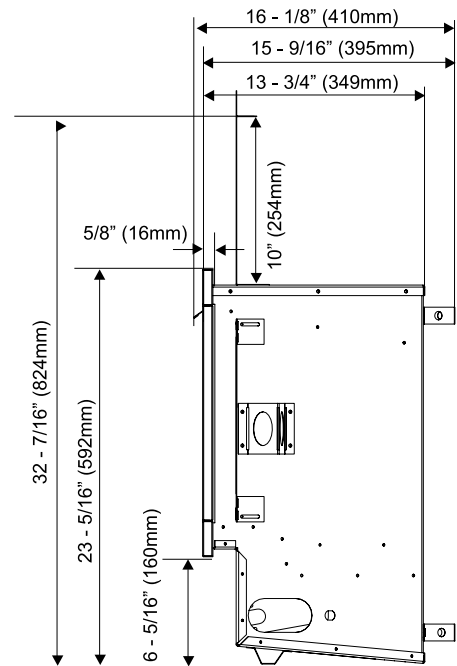
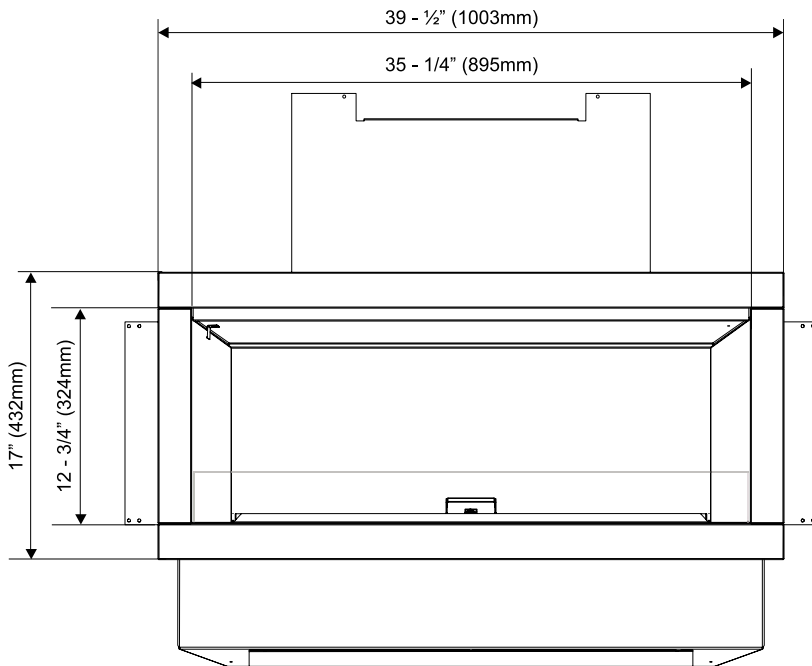

ALL PICTURES / DIAGRAMS SHOWN THROUGHOUT THIS MANUAL ARE FOR ILLUSTRATION PURPOSES ONLY. ACTUAL PRODUCT MAY VARY DUE TO PRODUCT ENHANCEMENTS.

GAS INSTALLATION CHECKLIST

This general checklist does not contain all pertinent installation details or specifics and does not supersede the guidelines in this manual. Your Regency dealer/installer should use it in conjunction with manual instructions. Please follow all local codes and jurisdictions in authority.

Customer: _____	Date Installed: _____	
Install Address: _____	Location of Fireplace: _____	
Serial No: _____	Installer: _____	
Model No: _____		
Site Requirements	YES	NO
If applicable, are the insulation, vapour barrier, and drywall present if installed on an outside wall or chase?		
Does the area have a solid continuous base to support the unit?		
Will the area accommodate the size of the appliance and all clearances?		
Are the gas and electrical roughed into the area where the unit is being installed?		
In City & Grandview series cool wall applications, is the chase enclosure sealed to prevent heat from escaping? All hot air from the unit must exit via the mandatory ventilation openings.		
In City & Grandview applications, Is the chase enclosure vented with the mandatory heat ventilation openings? See manual for details.		
If applicable, is the masonry/factory built fireplace in its original condition with no modifications?		
If applicable, have the hearth requirements been met?		
Unit Setup	YES	NO
If applicable, are the standoffs and top nailing flange extensions installed and at the correct depth to accommodate finishing material? See manual for details.		
If applicable, is the fireplace level and secured, meeting framing clearances? See manual for details.		
If applicable, is the unit converted to top or rear vent per manual instructions, and the insulation discarded?		
Venting	YES	NO
Are the venting components approved for the unit installed?		
Does the venting configuration comply with venting diagrams?		
Is venting installed and secured, and are clearances for the vent pipe and termination cap maintained?		
If applicable, was a 1/4" rise maintained for every foot of horizontal run?		
Was the termination installed and sealed?		
Is the direct vent termination at the highest point in the vent assembly?		
If applicable, are both chimney liners continuous from flue collars to termination?		
Electrical and Wiring	YES	NO
Is the appliance connected to the household's 110/120v per local codes? Check local codes for receptacle placement.		
Were the connections in the fireplace tested with a circuit tester?		
Is the appliance properly grounded?		
If applicable, is the supplied electrical/gang box affixed to the wall to facilitate the mounting of the receiver/battery box ?		
If applicable, is all electrical, Ethernet, HDMI, networking, optical, wire/cables, conduits, etc. run through the wood or steel stud work as wires/cables of any kind cannot be exposed directly above or over the fireplace?		
Gas	YES	NO
Does the supply pressure meet the requirements shown on the rating plate?		
Was a conversion performed?		
Was a leak check performed and manifold pressures verified?		

Is the shut-off valve installed and easily accessible to the customer?		
Finishing	YES	NO
If applicable, is only noncombustible material installed in the noncombustible areas?		
Do clearances meet installation and manual requirements?		
Do the mantels and/or projections comply with the installation manual?		
If applicable, was the solid fuel fireplace warning plate installed?		
Is the chase enclosure fully open the full width, height and depth above the fireplace as per the requirements noted in the framing section?		
Appliance Media Setup	YES	NO
Do commands from the remote or wall switch light the pilot and main burner?		
Are the burner media/log set, glass door, and screen installed per instructions in the manual?		
Was the air shutter on the proper setting after running the unit for 20 minutes?		
If applicable, were the surround and trims installed according to the manual?		
Was the operation of the fan, lights (if installed), and flame modulation checked?		
Customer Tutorial and Presentation	YES	NO
Is the customer confident operating the new gas appliance and aware of all the features on the remote?		
Confirm that the rating and lighting plates are attached to the appliance. Do not remove.		
Was the customer informed of the location of the rating and lighting plates?		
Was accessing unit controls in a power outage explained to the customer?		
Are the model and serial numbers and the date of installation of the unit written in the manual and on the checklist?		
Were the warranty and unit registration reviewed with the customer?		
Comments:		

**IMPORTANT MESSAGE
SAVE THESE INSTRUCTIONS**

The HZO42-11 Gas Fireplace must be installed in accordance with these instructions. Carefully read all the instructions in this manual first. Consult the "authority having jurisdiction" to determine the need for a permit prior to starting the installation. It is the responsibility of the installer to ensure this fireplace is installed in compliance with manufacturers instructions and all applicable codes.

BEFORE YOU START

Safe installation and operation of this appliance requires common sense, however, we are required by the Canadian Safety Standards and ANSI Standards to make you aware of the following:

INSTALLATION AND REPAIR SHOULD BE DONE BY AN AUTHORIZED SERVICE PERSON. THE APPLIANCE SHOULD BE INSPECTED BEFORE USE AND AT LEAST ANNUALLY BY A PROFESSIONAL SERVICE PERSON. MORE FREQUENT CLEANING MAY BE REQUIRED DUE TO EXCESSIVE LINT FROM CARPETING, BEDDING MATERIAL, ETC. IT IS IMPERATIVE THAT CONTROL COMPARTMENTS, BURNERS AND CIRCULATING AIR PASSAGEWAYS OF THE APPLIANCE BE KEPT CLEAN.

ANY GUARD OR OTHER PROTECTIVE DEVICE REMOVED FOR SERVICING THE APPLIANCE MUST BE REPLACED PRIOR TO OPERATING THE APPLIANCE

WARNING: FAILURE TO INSTALL THIS APPLIANCE CORRECTLY WILL VOID YOUR WARRANTY AND MAY CAUSE A SERIOUS FIRE.

CHILDREN AND ADULTS SHOULD BE ALERTED TO THE HAZARDS OF HIGH SURFACE TEMPERATURES, ESPECIALLY THE FIREPLACE GLASS AND FACEPLATE, AND SHOULD STAY AWAY TO AVOID BURNS OR CLOTHING IGNITION.

THIS APPLIANCE SHALL BE USED ONLY OUTDOORS IN A WELL-VENTILATED SPACE AND SHALL NOT BE USED IN A BUILDING, GARAGE OR ANY OTHER ENCLOSED AREA.

DO NOT USE THIS APPLIANCE IF ANY PART HAS BEEN UNDER WATER. IMMEDIATELY CALL A QUALIFIED SERVICE TECHNICIAN TO INSPECT THE APPLIANCE AND TO REPLACE ANY PART OF THE CONTROL SYSTEM AND ANY GAS CONTROL WHICH HAS BEEN UNDER WATER.

CLOTHING OR OTHER FLAMMABLE MATERIAL SHOULD NOT BE PLACED ON OR NEAR THE APPLIANCE.

YOUNG CHILDREN SHOULD BE CAREFULLY SUPERVISED WHEN THEY ARE IN THE SAME AREA AS THE APPLIANCE. TODDLERS, YOUNG CHILDREN AND OTHERS MAY BE SUSCEPTIBLE TO ACCIDENTAL CONTACT BURNS. A PHYSICAL BARRIERS IS RECOMMENDED IF THERE ARE AT RISK INDIVIDUAL IN THE HOUSE. TO RESTRICT ACCESS TO A FIREPLACE OR STOVE, INSTALL AN ADJUSTABLE SAFETY GATE TO KEEP TODDLERS, YOUNG CHILDREN AND OTHER AT RISK INDIVIDUALS OUT OF THE ROOM AND AWAY FROM HOT SURFACES.

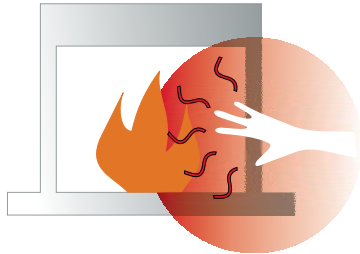

GENERAL SAFETY INFORMATION

1. When an appliance is for connection to a fixed piping system, the installation must conform with local codes or, in the absence of local codes, with the *National Fuel Gas Code, ANSI Z223.1 - NFPA 54; National Fuel Gas Code; Natural Gas and Propane Installation Code, CSA B149.1; or Propane Storage and Handling Code, CSA B149.2*, as applicable.
2. The appliance when installed, must be electrically grounded in accordance with local codes, or in the absence of local codes with the Canadian Electrical Code CSA C22.1 or with the National Electrical Code, ANSI/NFPA 70.

3. See general construction and assembly instructions. The appliance should be enclosed.
4. Inspect the burner before each use of the appliance for blockage and any signs of deterioration.
5. To prevent injury, do not allow anyone who is unfamiliar with the operation to use the fireplace.
6. Wear gloves and safety glasses for protection while doing required maintenance.
7. Maximum gas inlet pressure = 1/2 psig.
8. Under no circumstances should this appliance be modified. Parts that have to be removed for servicing should be replaced prior to operating this appliance.
9. Installation and any repairs to this appliance should be done by a qualified service person. A professional service person should be called to inspect this appliance annually. Make it a practice to have all of your gas appliances checked annually.
10. Under no circumstances should any solid fuels (wood, paper, cardboard, coal, etc.) be used in this appliance.
11. The appliance and its individual shutoff valve must be disconnected from the gas supply piping system during any pressure testing of that system at test pressures in excess of 1/2 psi (3.5kPa).
12. The appliance area must be kept clear and free of combustible materials, (gases and other flammable vapours and liquids).

It is highly recommended to protect the interior from moisture (rain, snow). Cover the enclosure opening when not in use. This fireplace is only for use with the type of gas indicated on the rating plate. This fireplace is not convertible for use with other gases, unless a certified kit is used.

13. Cover must be removed when burner is in operation.
14. When not using appliance for extended periods of time - turn off gas supply.
15. Do not operate this appliance with a remote control. Only use the ON/OFF switch supplied with this appliance. The ON/OFF switch must be placed within line of sight of the appliance.

 **WARNING: Cancer and Reproductive Harm**
www.P65Warnings.ca.gov

919-874

INSTALLATION CHECKLIST

- 1) Locate appliance:
 - a) Refer to "Locating Your Gas fireplace" section
 - b) Clearances to Combustibles (Refer to "Clearances" section)
 - c) Mantel Clearances (Refer to "Combustible Mantel Clearances" section)
 - d) Framing & Finishing Requirements (Refer to "Framing & Finishing" section)
- 2) Top Facing Support and Side Nailing Strips (Refer to "Unit Assembly Prior to Installation" Section). **Note:** Must be done before installing unit into place.
- 3) Drain Installation.
- 4) Install ON/OFF switch - ensure it is in the OFF position.
- 5) Make gas connections - test for leaks.
- 6) Install 4 "AA" batteries
- 7) Install standard and optional features. Refer to the following sections:
 - a. Steel Stud Framing Kit (Optional)
 - b. Hardwire Kit (Optional)
 - c. Inner Panel
 - d. Glass Crystals or Glass Fire Beads
 - e. Pebble Installation (optional)
 - f. Volcanic Stone Installation (optional)
 - g. Log Installation (optional)
 - h. Glass Wind Shield Installation
 - i. Heat Deflector Installation
 - j. Faceplate Installation
 - k. Weather Cover Installation

8) Final check.

This includes:

- 1) Clocking the appliance to ensure the correct firing rate (rate noted on label), after burning appliance for 15 minutes.
- 2) If required, adjusting the primary air to ensure that the flame does not carbon. First allow the unit to burn for 15-20 min. to stabilize.

CAUTION: Any alteration to the product that causes sooting or carboning that results in damage is not the responsibility of the manufacturer.

NOTE: In order to function correctly, these types of appliances require at least 50% open access for permanent ventilation/airflow. Open ventilation/airflow space comes from walls and roof/ceiling. Open floor space around the unit must not be considered ventilation/airflow space.

LOCATING YOUR GAS FIREPLACE

- 1) When selecting a location for your fireplace, ensure that the clearances are met.
- 2) This appliance must be installed in an open-air situation with natural ventilation, without stagnant areas, where gas leakage and products of combustion are rapidly dispersed by wind and natural convection.
- 3) Certain materials or items, when placed under or near the appliance, will be subjected to radiant heat and could become damaged.
- 4) Typically an outdoor space is not enclosed but, any enclosure in which the appliance is used shall comply with one of the following:

An enclosure with walls on all sides, but at least one permanent opening at ground level and no overhead cover.

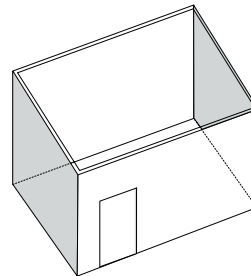

Within a partial enclosure that includes an overhead cover and no more that two walls.

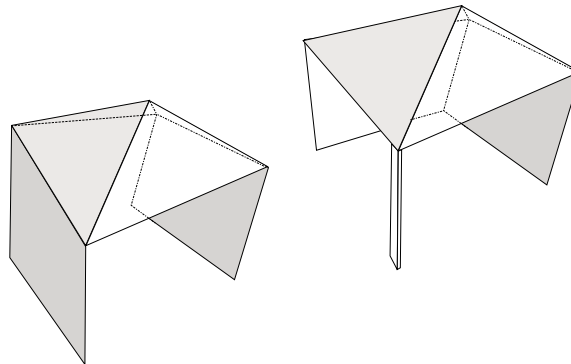

Within a partial enclosure that includes an overhead cover and more than two walls, the following shall apply:

- At least 25% of the total wall area is completely open, and
- At least 30% of the remaining wall area is open and unrestricted

30% or more in total of the remaining wall area is open and unrestricted.

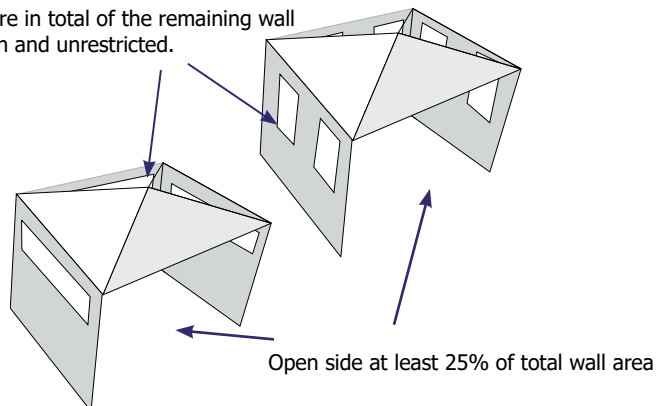

***SEE IMPORTANT INSTALLATION NOTES NEXT PAGE**

IMPORTANT INFORMATION FOR OUTDOOR FIREPLACE INSTALLATIONS

- Never insulate around the body of the unit
- Excessive heat retention in the firebox will lead to component failure and fireplace malfunction
- Excessive heat retention will also increase the risk of fire inside the chase
- Heat retention can cause "Oil-canning" and damage the fireplace due to overheating
- Do not build up a wall of any type in front or to the sides of the appliance, higher than the firebox opening. This will create a pressure zone at the firebox and will prevent the unit from venting
- This is an outdoor appliance with a built-in drain. This drain should be installed and connected in all applications as per the instructions in this manual
- Inadequate drainage will cause rust and reduce the life of your appliance, this is not protected by warranty

COMPONENTS IN OUTDOOR APPLIANCES

- Outdoor units use the same consistent, reliable Electronic components used in most Regency "E" units
- Installed correctly, these components will be subjected to far lower temperatures than indoor units, which have been certified as safe from heat etc
- Working gas pressures are as critical in outdoor products as they are in indoor products, even more important in Electronic systems

COMMON MISCONCEPTIONS REGARDING OUTDOOR FIREPLACES

- There is a common misconception that being outdoors, an Outdoor Fireplace will function, regardless of circumstances,
- Outdoor fireplaces require the same amount of ventilation as indoor units, often more
- Outdoor units require adequate ventilation to the atmosphere, which in turn provides ongoing circulatory combustion air
- This type of Appliance Vents.
- All Outdoor Fireplace Products have the same need for Air/Oxygen, and an ability to Vent
- Even though the appliance is outdoors, this doesn't mean it is getting adequate air
- Requirements are not specific to Regency units
- Read and follow critical location guidelines in this manual

UNDERSTANDING OUTDOOR APPLIANCE REQUIREMENTS

- Don't overlook the obvious
- Widen your margin for error
- Combustion always requires the same three elements
- Only the quantities and volumes change



IMPORTANT THINGS TO REMEMBER

- Correct Working Gas pressure is critical on "E" units
- Wherever possible avoid locating on a flat wall in a tight corner
- Floor space doesn't count as "open area"
- Install to the manual specs for framing and **do not insulate** unit or enclosure
- Framing enclosure must at least meet minimum dimensional specs as per the installation manual
- Only Regency approved media should be used in the firebox (i.e. stones/glass)
- Be aware of pressure zones due to location (i.e. facing the ocean)
- Open walls and doorways to outside air are beneficial to the performance of an outdoor appliance
- Fixed roof/ceiling open areas count towards the total open area overall requirement
- Screens create 40% or more air restriction
- Screened areas are restrictions and reduce open air space, calculate area based on a **closed** screen
- The biggest problems are created by lack of airflow for the appliance
- Outdoor fireplaces are often built-in systems and incorrect installation can result in high repair costs
- Units must not be modified or altered in any way

ANTICIPATED ISSUES CAUSED BY INCORRECT LOCATION OR INSTALLATION

- Unit shutting down intermittently
- Overheating of components leading to failure
- Lifting flame
- Poor flame package (i.e. all to one side, lazy flame)
- Failure to ignite
- Excess carbon
- Safety issues and concerns created from the byproducts of combustion

OUTDOOR APPLIANCES REQUIRE VENTING

- Outdoor appliances must be installed in: open-air situations with natural ventilation and without stagnant areas
- Any gas leakage and products of combustion need to be rapidly dispersed by wind and natural convection
- Typically outdoor spaces are not enclosed, however, failure to adhere to installation guidelines, may cause the outdoor fireplace to be affected by wind or air pressure inside the enclosure
- **ANY** enclosure in which the appliance is used shall comply with one of the diagrams on the previous page.

OUTDOOR APPLIANCE INSTALLATION SUMMARY

- All walls + overhead cover = 100% total area
- One of four walls or full overhead area must be totally open, plus—one of remaining walls must have a fixed opening
- All outdoor fireplaces/fire tables require total **natural** ventilation of 50% open space

MINIMUM CLEARANCES TO COMBUSTIBLES

The clearances listed below are minimum distances unless otherwise stated.

A major cause of fires is failure to maintain required clearances (air space) to combustible materials. It is of the greatest importance that this fireplace be installed only in accordance with these instructions.

Caution Requirements
 The top, back and sides of the fireplace are defined by standoffs. The metal ends of the standoff may **NOT** be recessed into combustible construction.

WARNING
Fire hazard is an extreme risk if these clearances (air space) to combustible materials are not adhered to. It is of greatest importance that this fireplace be installed only in accordance with these instructions.

HZO42-11 Clearance Requirements

Clearance	Dimension	Measured From:
A: Sidewall	11" (279mm)	Side of Fireplace Opening
B: Ceiling	36" (914mm)	Top of Fireplace Opening
C: Mantel Height (min.)	18" (457mm)	Top of Fireplace Opening
D: Mantel Depth (max.)	12" (304mm)	From Wall
E: Alcove Width	57"(1448mm)	Wall to Wall (Minimum)
F: Alcove Depth	36" (914mm)	Front to Back Wall (Maximum)
Notes:	0"	No Hearth Required

WARNING:
 When installing this appliance; do not cover or surround with insulation. This appliance can overheat and cause malfunction and component failure, if covered, or partially covered. If the appliance is installed inside a chase, insulation must be installed on the walls of the chase, not on the appliance.

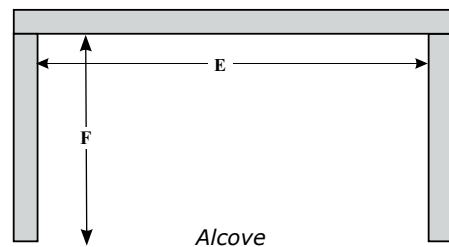
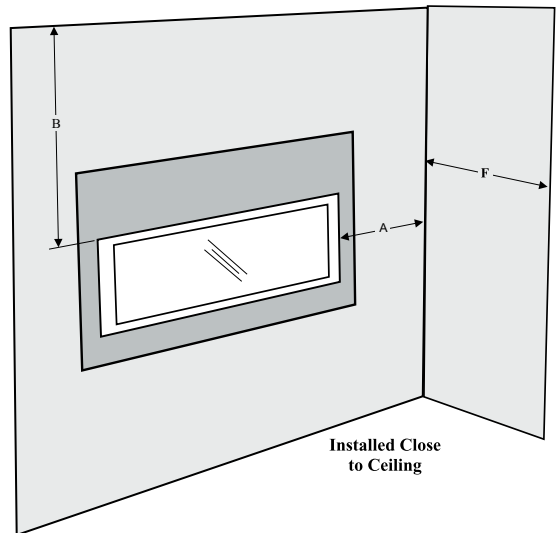
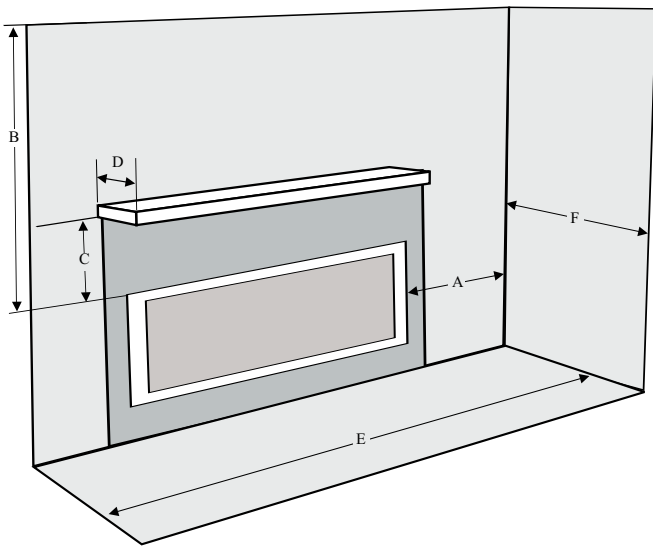

FRAMING DIMENSIONS

Framing Dimensions	Description	HZO42-11
A	Header Height	32-11/16" (30mm)
B	Side Stud Width	42 - 3/16" (1072mm)
C	Minimum framing depth	20" (508mm)
D	Minimum Height to Combustibles	52 - 1/2" (1334mm)
E	Minimum framing width	60" (1524mm)
F	Corner Wall Depth	40 - 7/16" (1027mm)
G	Corner Facing Wall Width	54 - 3/16" (1376mm)
H	Gas Connection Opening Height	2" (51mm)
I	Gas Connection Height	3-7/8 " (98mm)
J	Gas Connection Inset	3/4" (73mm)
K	Gas Connection Opening Width	3-7/8 " (98mm)

* Framing depth measurement is noted with the nailing strips set as far forward on the firebox as possible. The nailing strips can be adjusted back up to 1" to allow for varying thicknesses in non-combustible material & wall finishes.

Note: All other framing may be of wood construction.

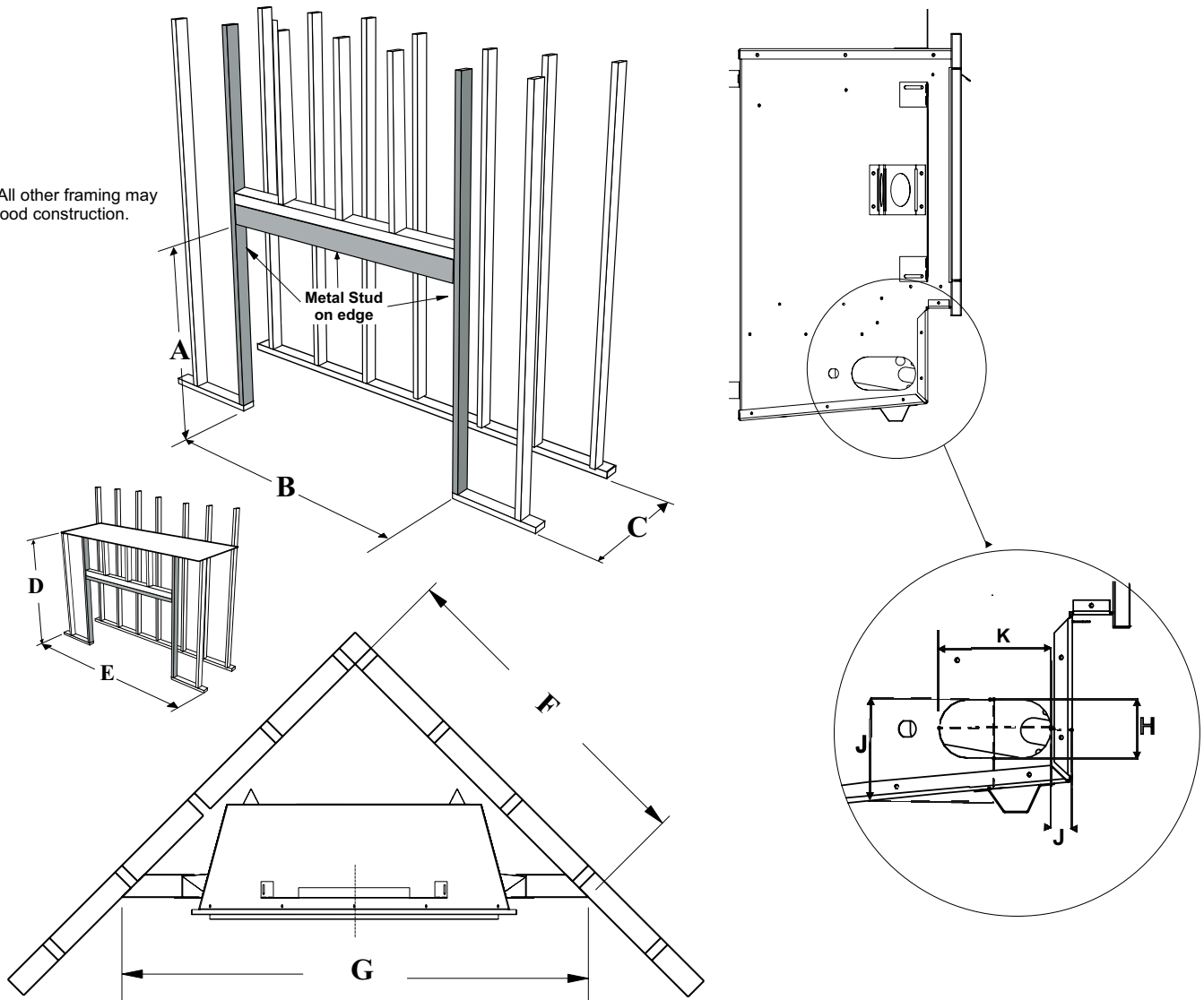

MANTEL CLEARANCES

Due to the extreme heat this fireplace emits, the mantel clearances are critical. Combustible mantel clearances from top of front facing are shown in the diagram on the right.

Note: Ensure the paint that is used on the mantel and the facing is "heat resistant" or the paint may discolour.

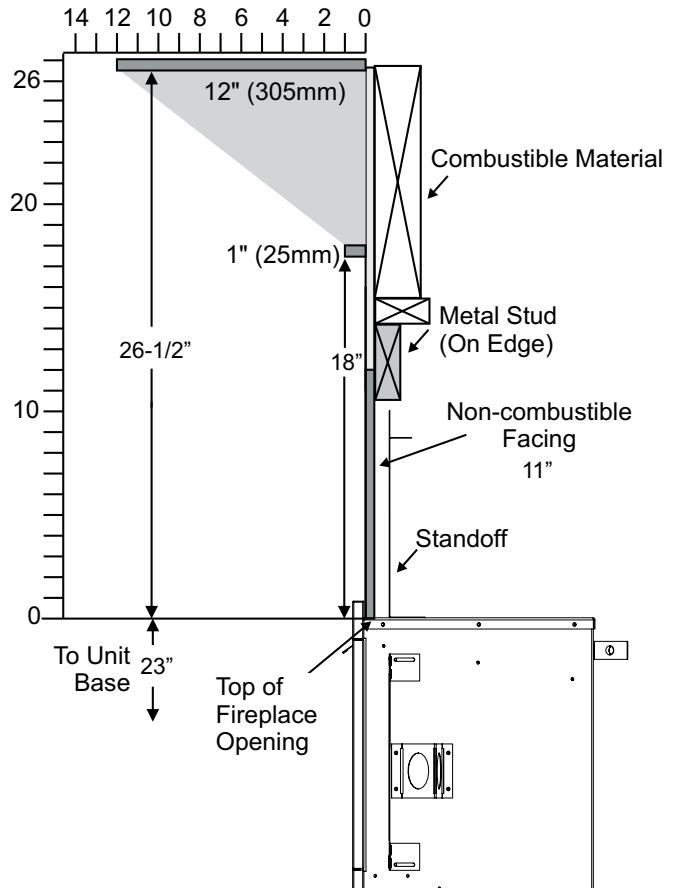

NON-COMBUSTIBLE REQUIREMENTS

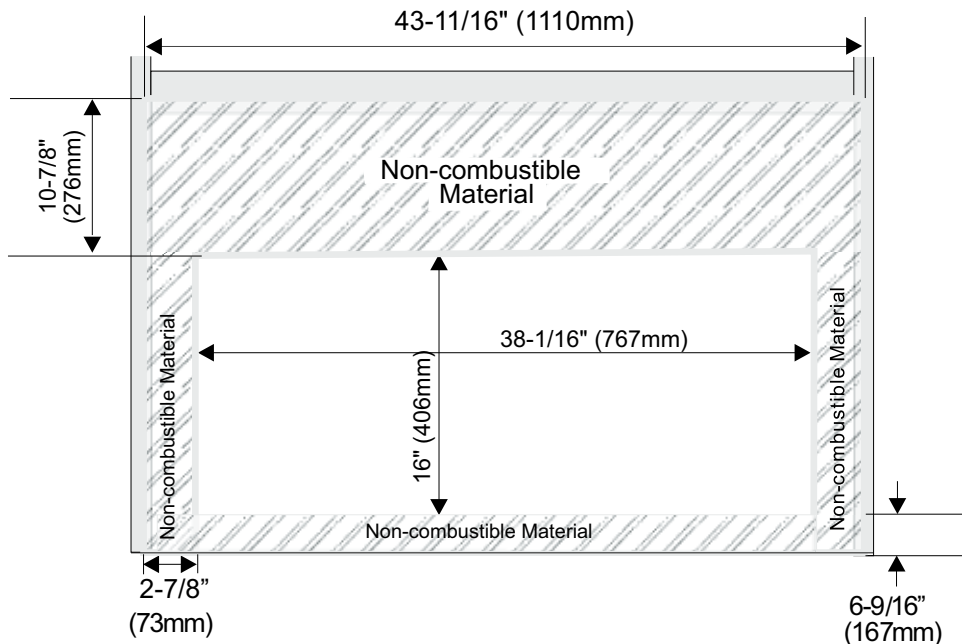

HZO42 ENCLOSURE VENT INSTALLATION

Four (4) ventilation grills are required for all enclosures. Two (2) upper and two (2) lower ventilation grills are required for all enclosures. This is to alleviate moisture and allow for air to circulate. Minimum recommended size: 20" sq. (508 mm²) ea.

If using the grills offered by Regency (supplied), follow the instructions noted below:
Frame the opening for the upper vent (377-060) at 16" x 1-1/4" - secure the upper vent to the framing with 6 screws.

Frame the opening for the lower vent (377-061) at 8" x 2-7/8" - secure the lower vent with 10 screws.

We highly recommend installing these upper and lower grills at either end of the framed structure to allow the air to circulate from one end to the other.
Note: If purchasing grills elsewhere, ensure the minimum recommended size of 20"sq. (508 mm²) each is met.

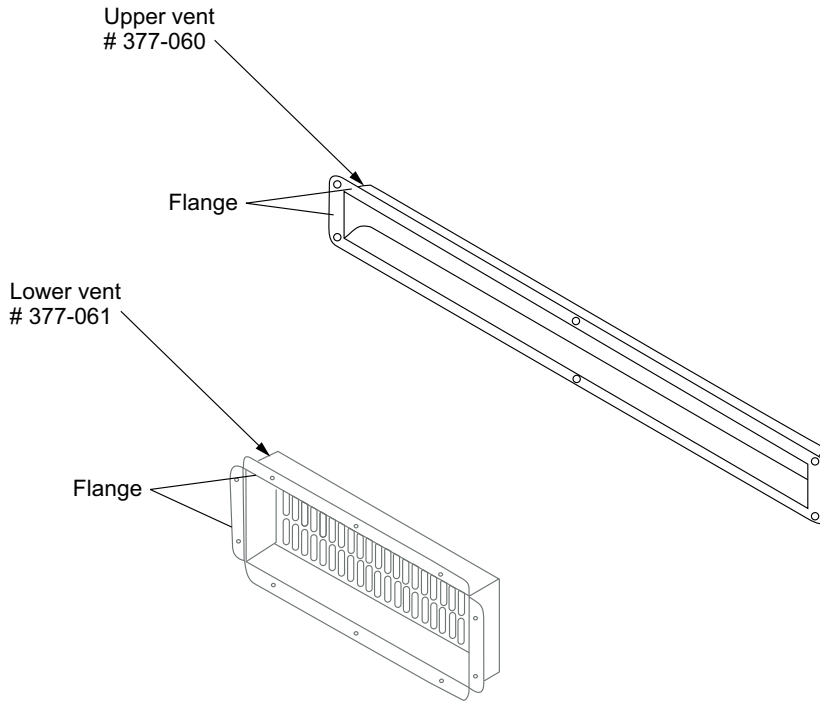

Note: Finishing material can be brought over the flange of the ventilation grills to ensure a clean look.

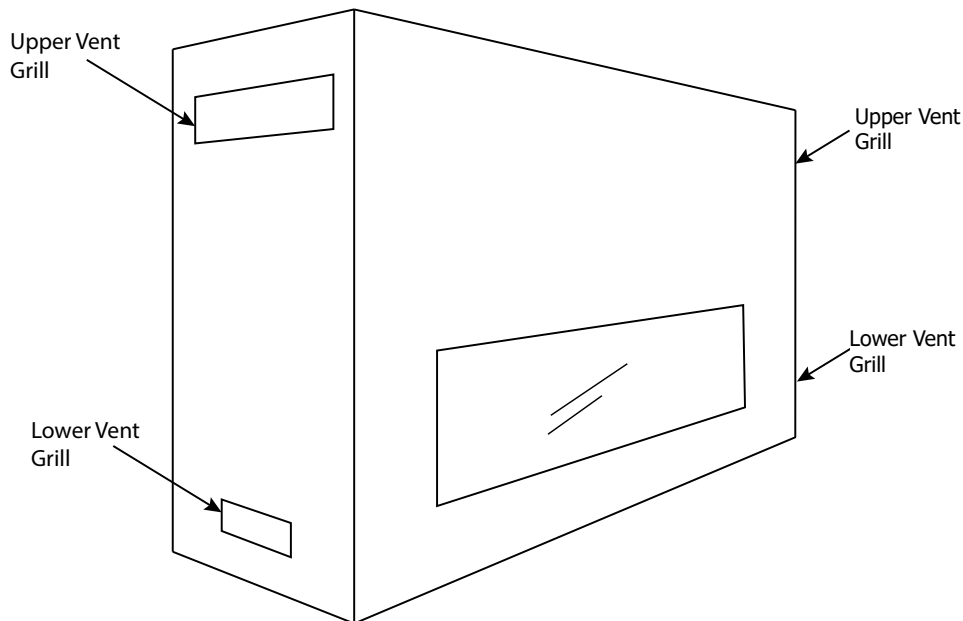

FINISHING

IMPORTANT FINISHING DETAIL NOTE:

Before placing unit into final position - it is important to know the total thickness / height of finished hearth. The base of the fireplace should be level or higher than the finished hearth height.

If material such as brick, stone, etc extends past the faceplate depth (1-1/2"), when finishing around the faceplate, the minimum opening dimensions noted below must be adhered to ensuring for the removal of the faceplate and for the safe operation of this appliance.

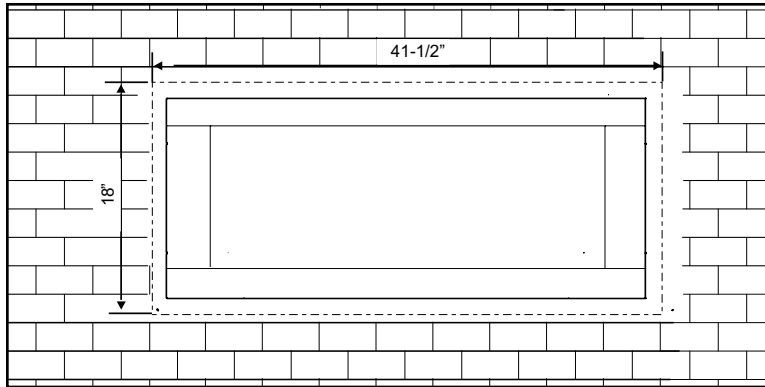

For material such as brick, stone, etc that extend up to 1-1/2" , the minimum opening dimensions noted below must be adhered, when finishing around the faceplate. This is to ensure the removal of the faceplate and for the safe operation of this appliance. The maximum allowable combined thickness of non combustible material (i.e. durarock, concrete board, etc.) and finishing materials such as brick, stone, etc. cannot exceed 5" (127 mm).

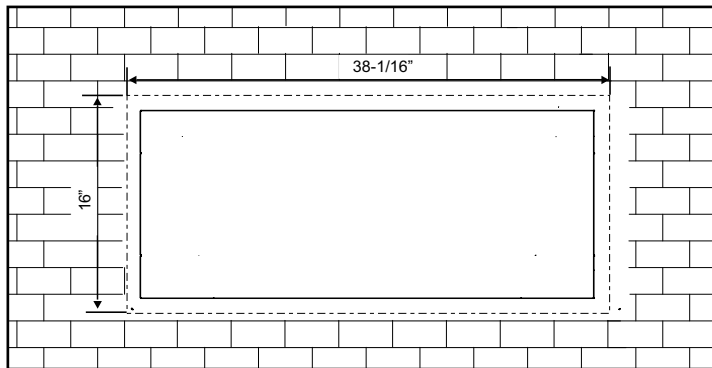

Unit shown without faceplate

For facing/finishing material over 1-1/2" (38mm) thick, use the outer cut out for your faceplate template.

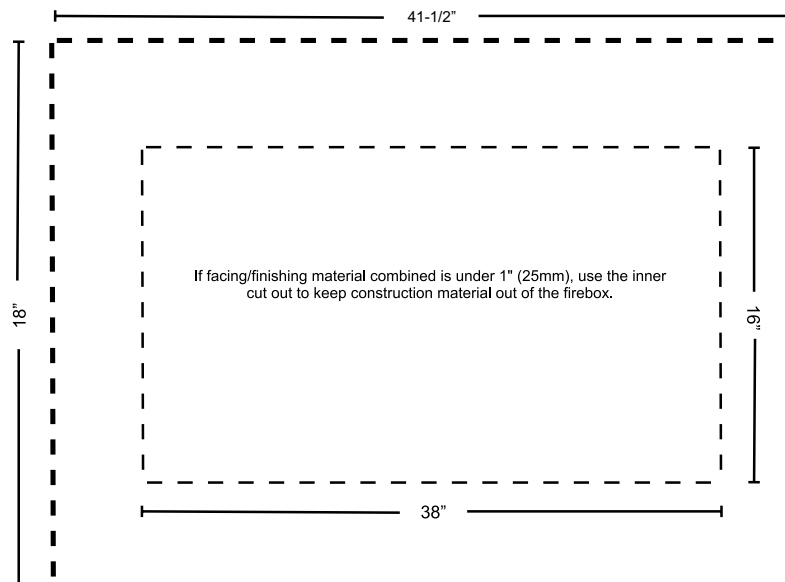

HZO42-NG11 SYSTEM DATA	
Max. Supply Pressure	14" WC (3.49 kPa)
Min. Supply Pressure	5" WC (1.25 kPa)
Manifold Pressure	3.5" WC (0.87 kPa)
Orifice Size	#29 DMS
Maximum Input	44,500 Btu/h (13.04 kW)

HZO42-LP11 SYSTEM DATA	
Max. Supply Pressure	14" WC (3.49 kPa)
Min. Supply Pressure	11" WC (2.73 kPa)
Manifold Pressure	10" WC (2.49 kPa)
Orifice Size	#47 DMS
Maximum Input	43,500 Btu/h (12.74 kW)

HIGH ELEVATION

This unit is approved for altitude 0 to 4500 ft. (CAN1 2.17-M91).

GAS LINE INSTALLATION

Since some municipalities have additional local codes it is always best to consult with your local authorities and the CSA B149.1 installation code.

For USA installations follow local codes and/or the current National Fuel Gas Code, ANSI Z223.1.

When using copper or flex connectors use only approved fittings. Always provide a union so that gas lines can be easily disconnected for servicing. Flare nuts for copper lines and flex connectors are usually considered to meet this requirement.

NOTE: A shutoff / dante valve should be supplied in or near the unit (or as per local codes) for ease of servicing this appliance.

IMPORTANT: Always check for gas leaks with a soap and water solution or gas leak detector. Do not use open flame for leak testing.

PILOT ADJUSTMENT

Periodically check the pilot flames. Correct flame pattern has two strong blue flames: 1 flowing around the flame sensor and 1 flowing across the burner (it does not have to be touching the burner).

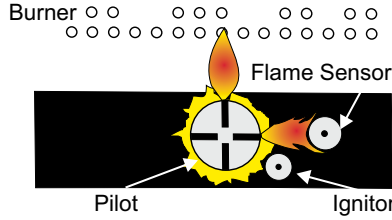

Note: If you have an incorrect flame pattern, contact your Regency® dealer for further instructions.

Incorrect flame pattern will have small, probably yellow flames, not coming into proper contact with the rear burner or flame sensor.



Correct flame pattern

GAS PIPE PRESSURE TESTING

The appliance must be isolated from the gas supply piping system by closing its individual manual shut-off valve during any pressure testing of the gas supply piping system at test pressures equal to or less than 1/2 psig. (3.45 kPa). Disconnect piping from valve at pressures over 1/2 psig.

The manifold pressure is controlled by a regulator built into the gas control, and should be checked at the pressure test point.

Note: To properly check gas pressure, both inlet and manifold pressures should be checked using the valve pressure ports on the valve.

- 1) Make sure the valve is in the "OFF" position.
- 2) Loosen the "IN" and/or "OUT" pressure tap(s), turning counterclockwise with a 1/8" wide flat screwdriver.
- 3) Attach manometer to "IN" and/or "OUT" pressure tap(s) using a 5/16" ID hose.
- 4) Light the pilot and turn the valve to "ON" position.
- 5) The pressure check should be carried out with the unit burning and the setting should be within the limits specified on the safety label.
- 6) When finished reading manometer, turn off the gas valve, disconnect the hose and tighten the screw (clockwise) with a 1/8" flat screwdriver. **Note: Screw should be snug, but do not over tighten.**

880 S.I.T. VALVE DESCRIPTION

- 1) Pilot adjustment
- 2) Outlet Pressure Tap
- 3) Inlet Pressure Tap
- 4) Pilot Outlet
- 5) Main Gas Outlet
- 6) Main Gas Inlet

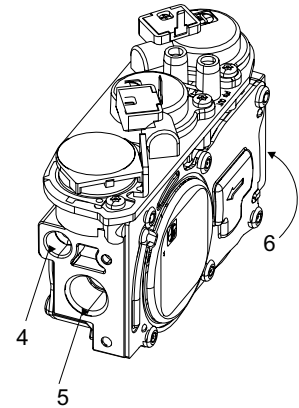
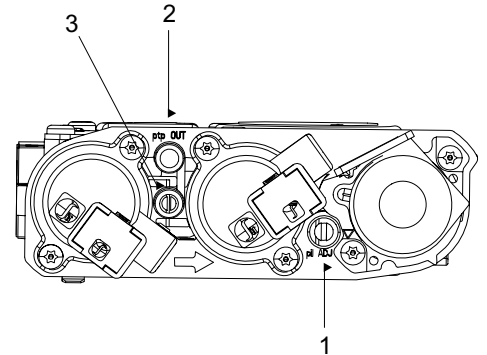

AERATION ADJUSTMENT

The burner aeration is factory set but may need adjusting due to either the local gas supply or altitude. Open the air shutter for a blue flame or close for a more yellow flame.

Minimum Air Shutter Opening:

1/8"	NG
1/4"	LP

Note: Any damage due to carboning resulting from improperly setting the aeration controls is NOT covered under warranty.

UNIT ASSEMBLY PRIOR TO INSTALLATION

The 6 Standoffs must be correctly positioned and attached before unit is slid into position.

STANDOFF ASSEMBLY

The standoffs are shipped in a flat position and must be folded into shape and attached.

- 1) Remove the standoffs from the fireplace.
- 2) Take each standoff and bend into the correct shape. Bend up at the bend lines until the screw holes in the standoff and the pre-punched screw holes on the fireplace top line up.
- 3) Attach the standoff securely to the unit with 2 screws per standoff (on opposite corners).

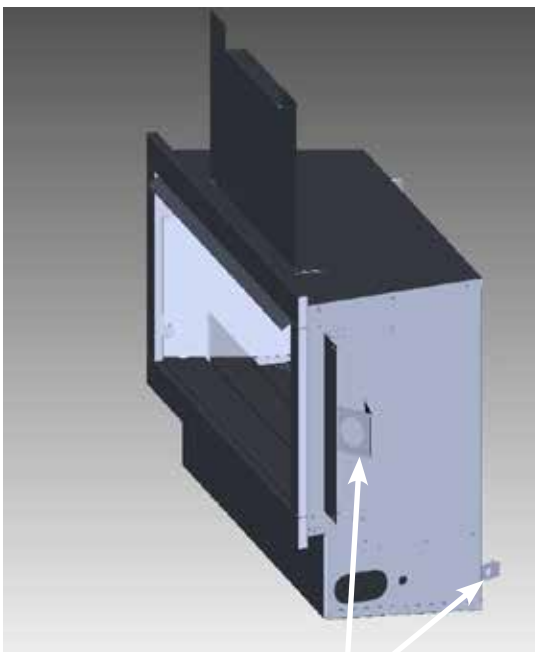
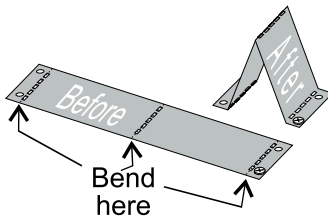

Standoffs installed

Note:
Depending on the material used for finishing, the nailing strips must be set accordingly so that the finished material is always at the 1-1/2" edge of the flange.

NAILING STRIPS

The nailing strips come attached to the unit. There is 1 plate on each side and 1 on the top that can be folded out as required. Secure the top and side nailing strips to the framing.

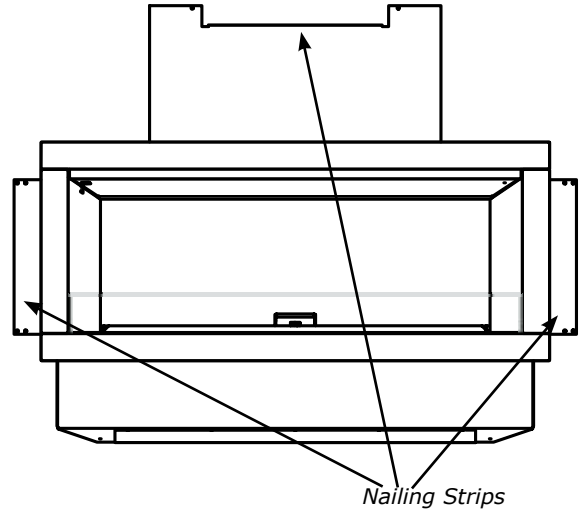

Finished Material	Nailing Strip Position	
1/2"	1"	<p>Nailing Strip 1" Forward</p> <p>Unit</p>
1"	1/2"	<p>Nailing Strip 1/2" Forward</p> <p>Unit</p>
1-1/2"	0" (flush)	<p>Nailing Strip Flush w/unit Factory Set</p> <p>Unit</p>

DRAIN INSTALLATION (RECOMMENDED)

Although this fireplace is designed to operate outdoors safely, rain and other sources of moisture may enter the hearth area, which will cause water to collect inside the base of the unit.

To prevent excessive water collection, the installer must provide a way to drain the water from the base of the unit by building or installing a water collector before positioning the fireplace in its location.

INSTALLATION INSTRUCTIONS

When planning for the installation of the unit, the framing height must be increased by 3/4", when installing a drain pan. Additional space below the unit will also be required to plumb a drain line.

- 1) Remove 4 screws to remove the rear access panel from the back of the unit - this will allow access to the drain hole at the base of the unit.
- 2) On the exposed drain hole (see location below), install a PVC 3/4" threaded coupling reducer going from the top of the pan, down through the hole. Apply a silicone-based sealant around the base and threads before installation.
- 3) Holding the reducer coupling with a wrench, thread a 90° PVC elbow (from the underside of the unit) to the reducer until it is tight to the metal.

Note: To assure proper drainage, that fireplace must be installed on a leveled surface

- 4) Add additional piping to route the drain to an appropriate location.

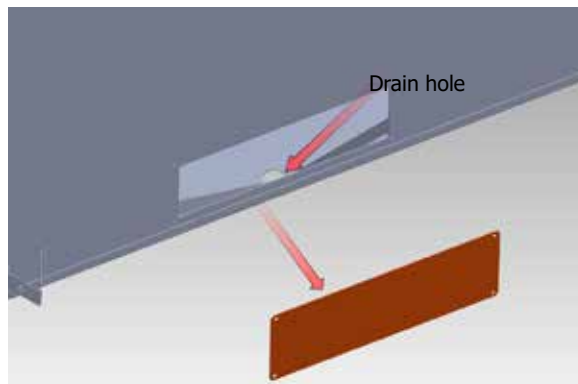
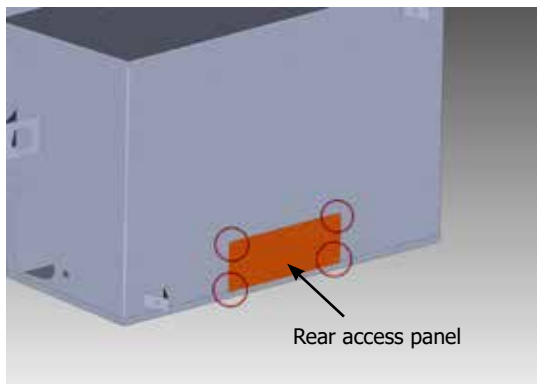

Cut notches into the top of the coupling reducer to prevent water pooling.

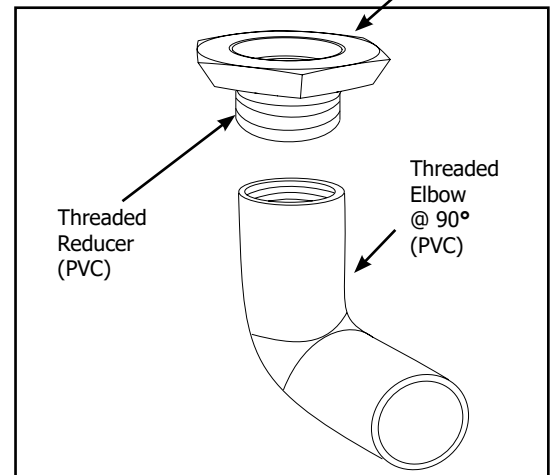
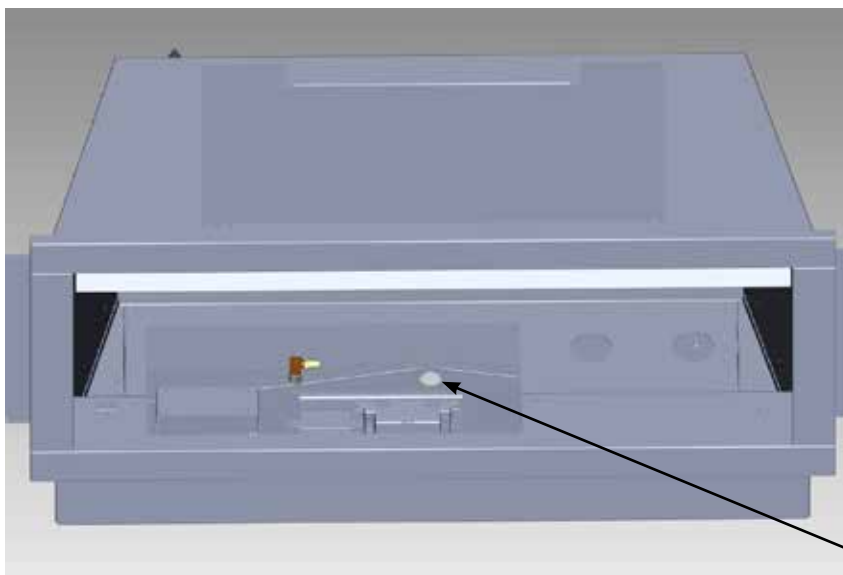

Reducer and elbow can be purchased from your local hardware store.

Drain hole location at base of the unit

WARNING: Failure to position the parts in accordance with these diagrams or failure to use only parts specifically approved with this appliance may result in property damage or personal injury.

WALL SWITCH AND BATTERY INSTALLATION (INCLUDED WITH UNIT)

The unit comes with low voltage wire and a battery extension wire installed.

- 1) Run supplied wire to desired location - to a max. of 9 feet.
- 2) Install supplied electrical box in desired location.



- 3) Remove center knock out from electrical box and install strain relief (strain relief nut not required).



Center Knock Out

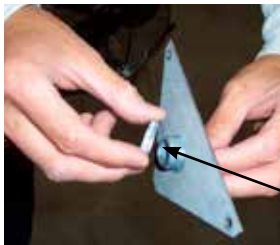

Strain Relief

- 4) Route low voltage wire and battery extension wire through the strain relief.
- 5) Connect low voltage wire to supplied switch, fasten switch to right side of electrical box (polarity not important).



- 6) Install supplied 4-AA batteries into the battery holder. Using velcro install battery holder to the backside of the battery compartment door. Connect battery terminal.
- 7) Using silicone, completely seal strain relief to protect from water or moisture.



- 8) Place supplied gasket on top of electrical box.
- 9) Fasten cover to electrical box using supplied screws.
- 10) Place switch in OFF position until final installation is complete.



WARNING: Failure to position the parts in accordance with these diagrams or failure to use only parts specifically approved with this appliance may result in property damage or personal injury.

WIRING DIAGRAM

This heater does not require a 120V A.C. supply for operation. (Do not cut the ground terminal off under any circumstances.)

NOTE: 4 AA batteries must be installed in the battery pack to operate the burner switch.

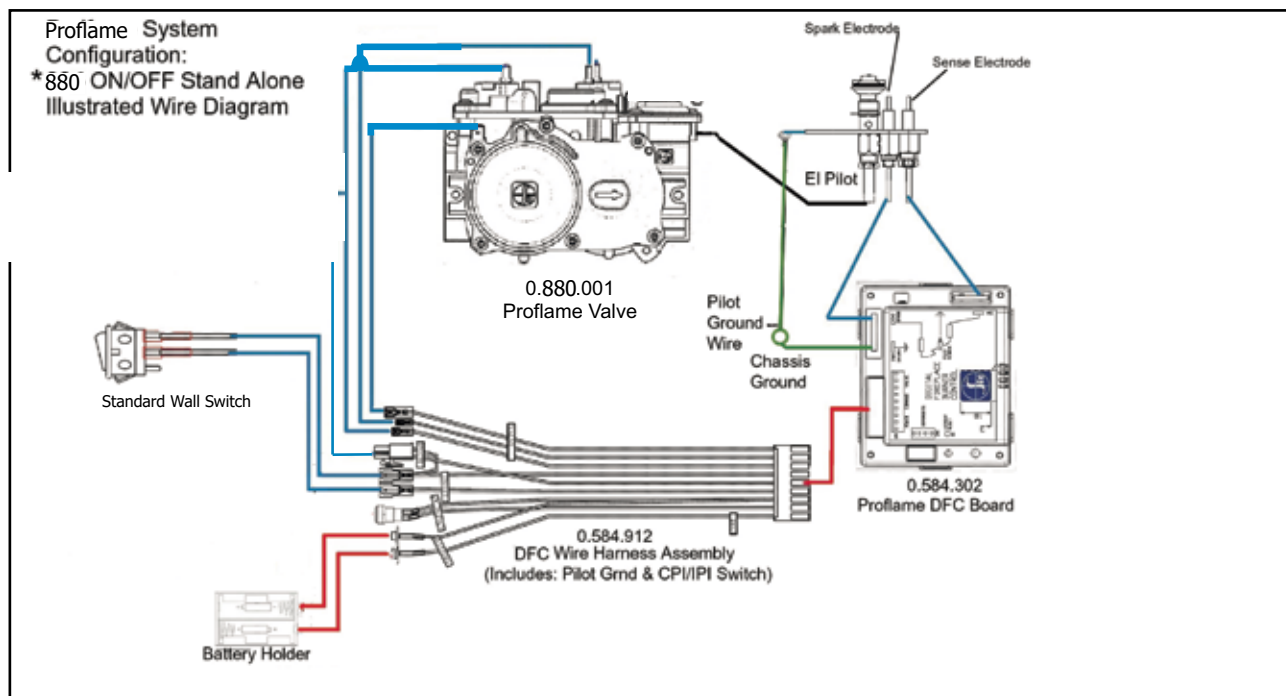

Remove the protective coating from the following components before proceeding. Carefully follow stainless handling instructions on following page.

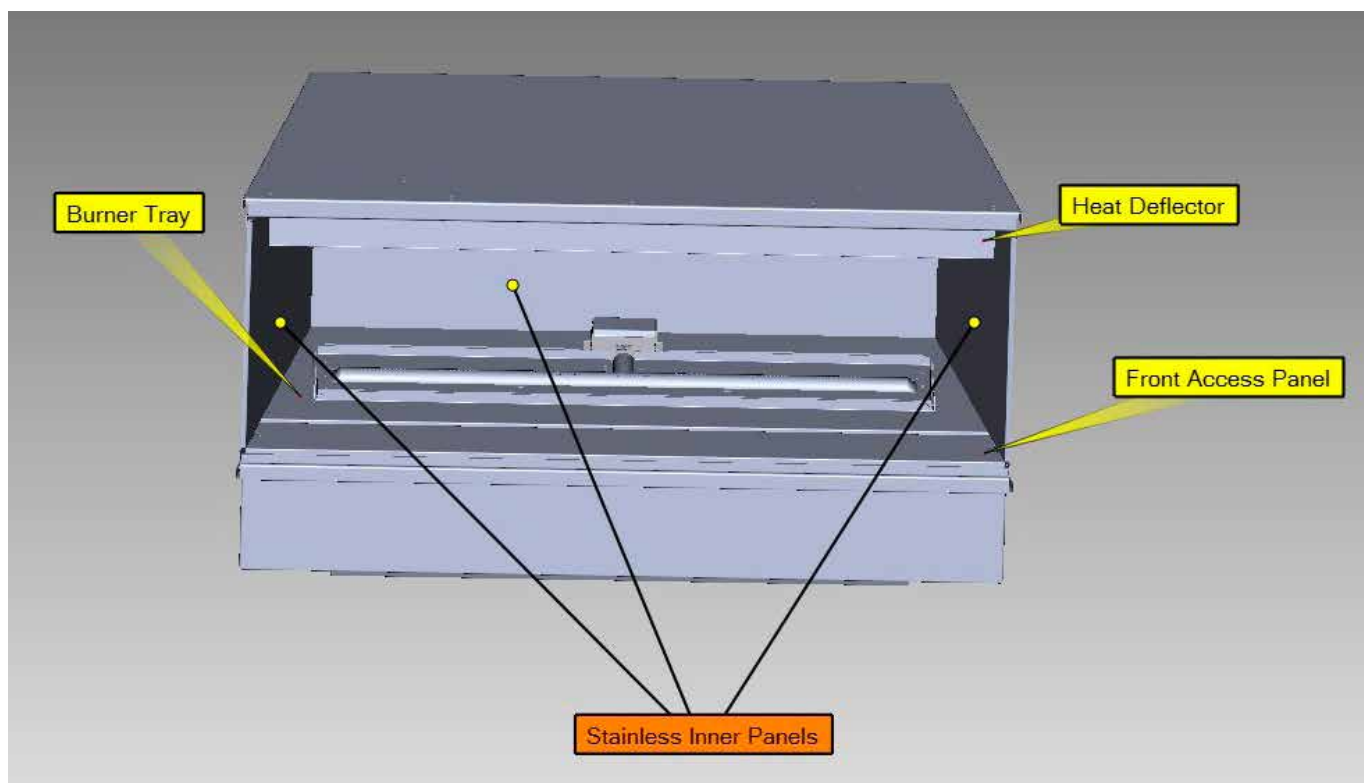

HARDWIRE KIT INSTALLATION

A hard wire kit is available for this unit as an option, to hard wire this appliance, a qualified electrician must remove the cord connection, and wire the appliance directly to the household wiring.

This appliance must be electrically connected and grounded in accordance with local codes, if hard wired.

In the absence of local codes, use the current CSA C22.1 CANADIAN ELECTRICAL CODE in Canada or the current ANSI/NFPA 70 NATIONAL ELECTRICAL CODE in the United States.

WARNING!

- USE ONLY A GROUND FAULT INTERRUPTER (GFI) PROTECTED CIRCUIT WITH THIS OUTDOOR GAS APPLIANCE .
- ENSURE THAT ALL POWER SOURCES HAVE BEEN SHUT OFF PRIOR TO BEGINNING ANY ELECTRICAL WORK.
- DO NOT USE THIS APPLIANCE IF ANY PART HAS BEEN UNDER WATER.
- CALL A QUALIFIED SERVICE TECHNICIAN IMMEDIATELY TO HAVE THE APPLIANCE INSPECTED FOR DAMAGE TO THE ELECTRICAL CIRCUIT.
- RISK OF ELECTRICAL SHOCK OR EXPLOSION. DO NOT WIRE 110V TO THE VALVE OR TO THE APPLIANCE WALL SWITCH.
- INCORRECT WIRING WILL DAMAGE CONTROLS AND IS NOT COVERED BY THE WARRANTY.
- ALL WIRING SHOULD BE DONE BY A QUALIFIED ELECTRICIAN AND SHALL BE IN COMPLIANCE WITH LOCAL CODES. IN THE ABSENCE OF LOCAL CODES, USE THE CURRENT CSA22.1 CANADIAN ELECTRIC CODE IN CANADA OR THE CURRENT NATIONAL ELECTRIC CODE ANSI / NFPA NO. 70 IN THE UNITED STATES.

Important : This electrical box must be located within 10 feet of the burner(s) as the AC adaptor is 10 feet long and will not reach the DC supply wire connection if any farther.

Note (PTO30/PTO50 only): If 2 burners are used, an additional AC adapter will be required to power the second burner.

The 4 AA batteries do not need to be installed if using the AC adaptor. The batteries would only be required in the event that 120V power is lost.

SHUT OFF GAS AND ELECTRICAL SUPPLY BEFORE STARTING THIS INSTALLATION.

1. Install electrical box into the outer box with 4 screws (Diagram 1).
2. Depending on which side (or conduit size) the electrical outlet will be installed, remove the corresponding knockouts in the outer box and electrical box to allow access for the conduit wiring (supplied by others) (Diagram 1).

ALL WIRING SHOULD BE DONE BY A QUALIFIED ELECTRICIAN

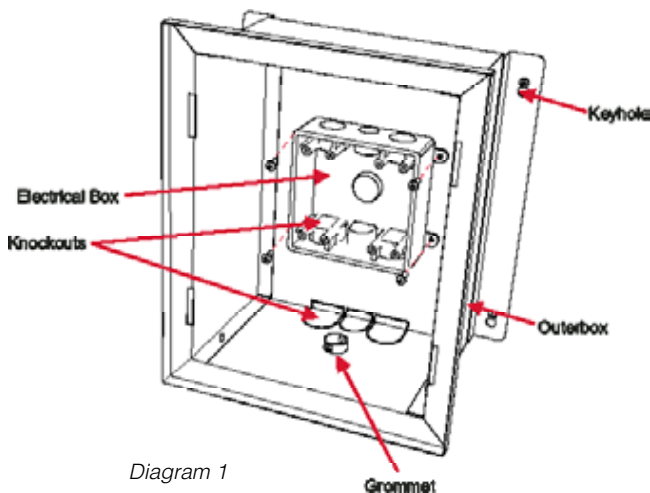
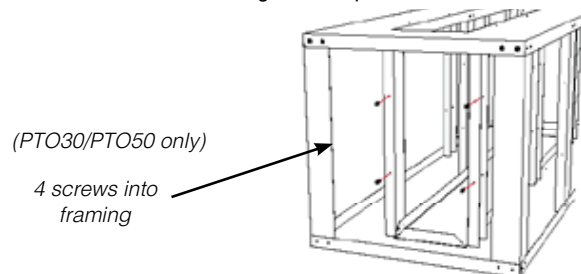

Diagram 1

Install electrical box into the outer box with 4 screws.

3. Install 4 screws into existing holes in the interior if using the optional framing kit in locations shown in the diagram below. Keep screws loose--do not tighten.

NOTE: If the optional framing is not used the outer box can be installed into conventional framing. See Step 14.



In the diagram below the outer box is installed. To install the outer box, line up the keyholes on the box with corresponding screws (installed in previous step) on the framing kit. When the box is in position, tighten the screws. (PTO30/PTO50 only).

4. Run the conduit to the electrical box through the knockout and complete the wiring of the electrical to the GFI circuit supplied with the kit. Once electrical wiring is complete, Secure both the GFI circuit and white blanking plate to the electrical box using 2 screws each.

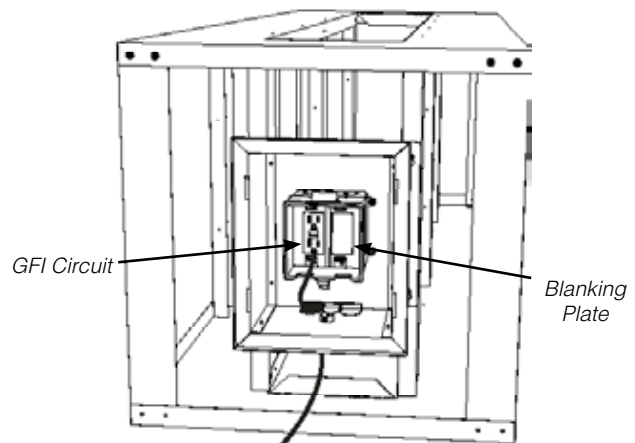

5. Plug in the supplied AC adaptor and run the wire through the bottom of the outer box, be sure to use a grommet to protect the wire.



6. Run the AC adaptor wire from the recently installed electrical box, to the back of the unit end.

7. Attach the AC adaptor to the DC supply wire. Secure wire using a strain relief (see enclosed picture). Reinstall the valve cover plate (reverse Step 6).



PTO30/PTO50/HZO60

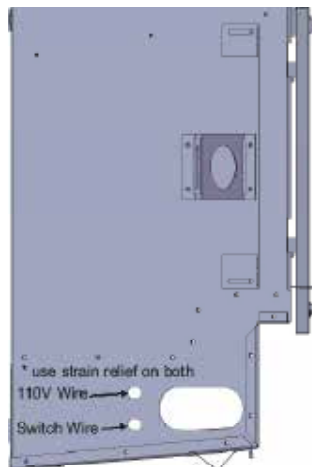

HZO42

8. Remove the valve cover plate on side of unit to expose the DC supply wire by removing 6 screws (PTO30/PTO50/HZO60 only)

NOTE: The valve cover plate should be removed prior to being installed into the framing kit or framing in general for ease of access to these 6 screws. This would also apply when reinstalling the valve cover plate.

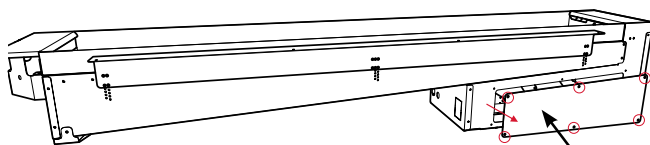

Valve cover plate
(PTO30/PTO50/HZO60 only)

9. HZO42/HZO60 only - Note: Remove glass windshield(s) if installed - Remove the front access panel by lifting up and out.

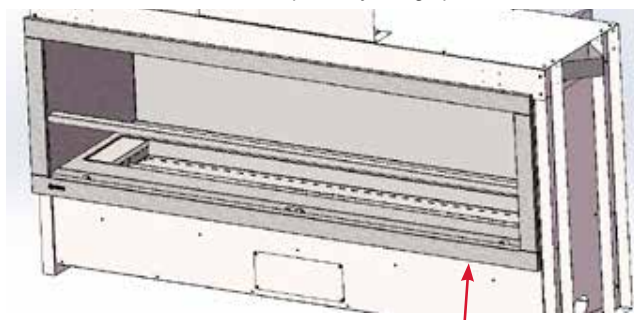

10. HZO42/HZO60--Remove the burner tray by lifting up and out.

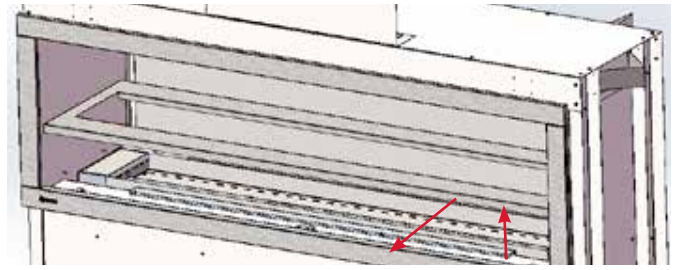

- HZO42 only- remove 6 screws in locations shown below to access DC supply.



11. Locate the 'DC supply' wire on the wiring harness, the wire will be clearly marked 'DC supply'. See 'AC Adaptor Install' in the manual.

12. Secure protective cover with lid to the receptacle box with 4 screws.

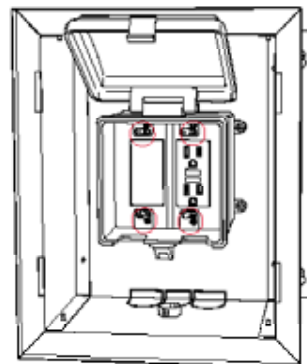

Protective cover
with lid

13. Install cover onto outer box.

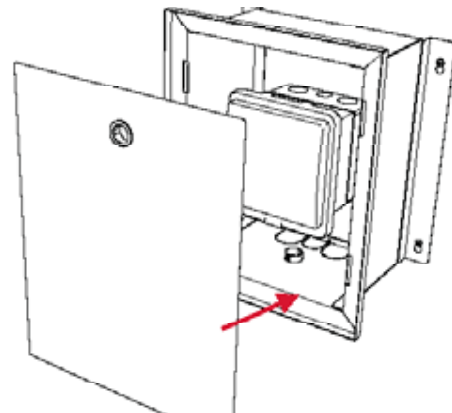

14. Turn on gas and electrical supply and test unit.

15. PTO100 Only:

If a second AC adaptor is required to power a second burner, repeat steps 5-9.

16. Installing the outer box into conventional framing:

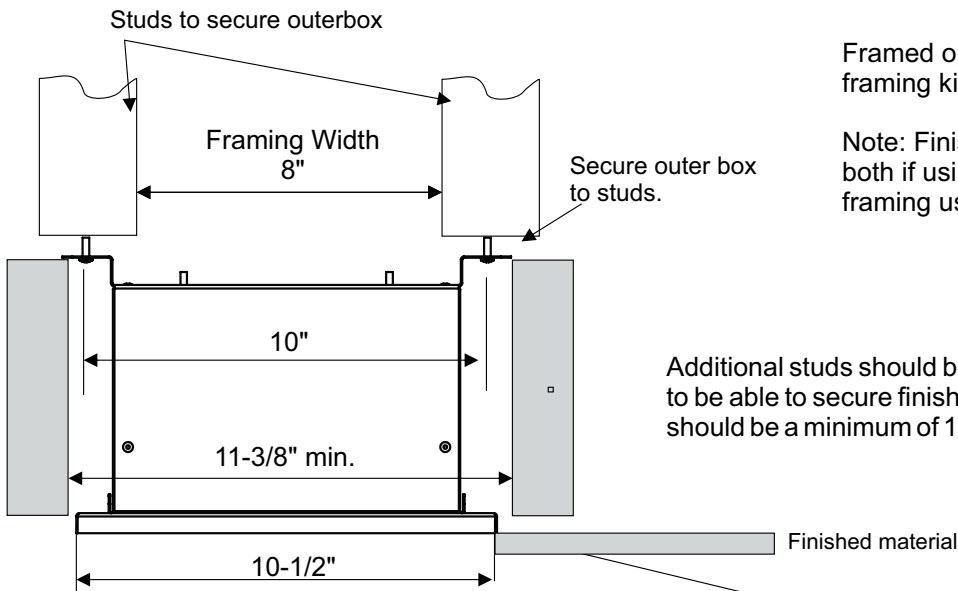

Framed opening, if not using steel stud framing kit.

Note: Finished materials would apply to both if using the steel stud kit or framing using other materials.

Additional studs should be placed anywhere in this area to be able to secure finished materials. Framed opening should be a minimum of 11 3/8".

Top View

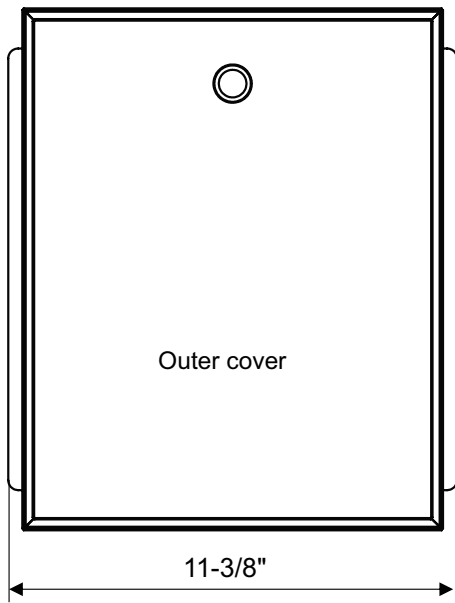

Front View

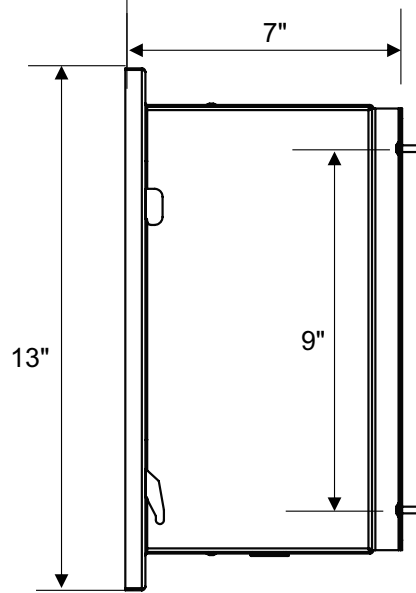

Side View

The front outer cover may also be covered with finishing materials if desired. Ensure that the outer cover when using finished materials, that it may be removed if access is ever required to the GFI circuit.

WARNING: Failure to position the parts in accordance with these diagrams or failure to use only parts specifically approved with this appliance may result in property damage or personal injury.

**PTO50/PTO30/HZO42 WIRING DIAGRAM
USING AC ADAPTOR**

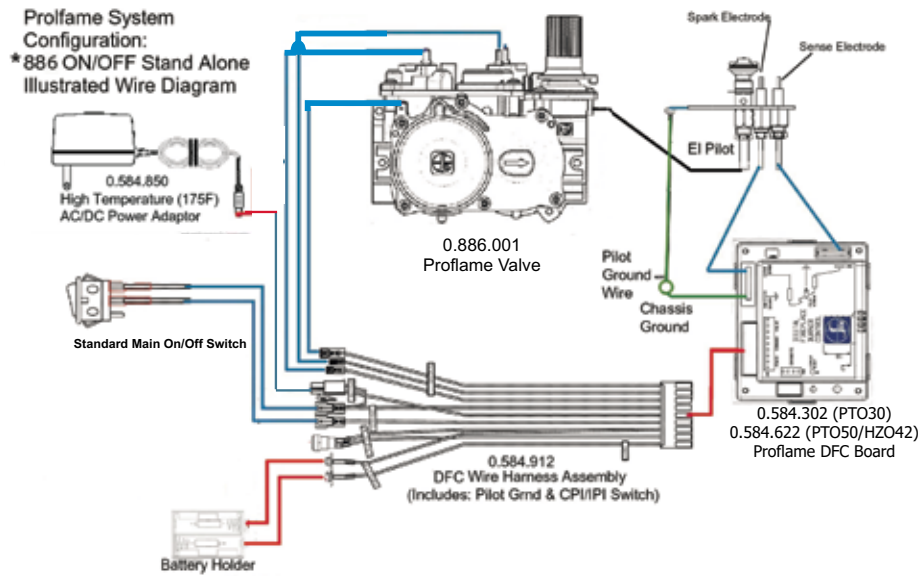

**PTO100/PTO60 WIRING DIAGRAM
(2 X PTO50 / 2 X PTO30 ASSEMBLED END-TO-END)
USING AC ADAPTOR**

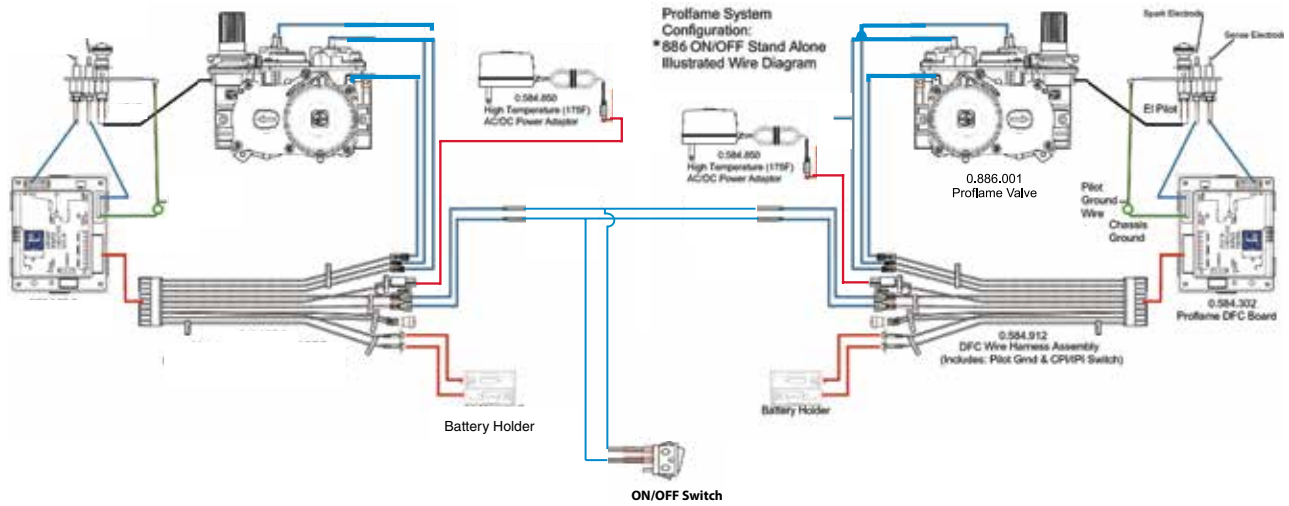

AC ADAPTOR INSTALLATION

A hard wire kit is available for this unit as an option (see hard wire kit instructions), to hard wire this appliance, a qualified electrician must remove the cord connection, and wire the appliance directly to the household wiring. This appliance must be electrically connected and grounded in accordance with local codes, if hard wired. In the absence of local codes, use the current CSA C22.1 CANADIAN ELECTRICAL CODE in Canada or the current ANSI/NFPA 70 NATIONAL ELECTRICAL CODE in the United States.

WARNING!

- USE ONLY A GROUND FAULT INTERRUPTER (GFI) PROTECTED CIRCUIT WITH THIS OUTDOOR GAS APPLIANCE .
- ENSURE THAT ALL POWER SOURCES HAVE BEEN SHUT OFF PRIOR TO BEGINNING ANY ELECTRICAL WORK.
- DO NOT USE THIS APPLIANCE IF ANY PART HAS BEEN UNDER WATER.
- CALL A QUALIFIED SERVICE TECHNICIAN IMMEDIATELY TO HAVE THE APPLIANCE INSPECTED FOR DAMAGE TO THE ELECTRICAL CIRCUIT.
- RISK OF ELECTRICAL SHOCK OR EXPLOSION. DO NOT WIRE 110V TO THE VALVE OR TO THE APPLIANCE WALL SWITCH.
- INCORRECT WIRING WILL DAMAGE CONTROLS AND IS NOT COVERED BY THE WARRANTY.
- ALL WIRING SHOULD BE DONE BY A QUALIFIED ELECTRICIAN AND SHALL BE IN COMPLIANCE WITH LOCAL CODES. IN THE ABSENCE OF LOCAL CODES, USE THE CURRENT CSA22.1 CANADIAN ELECTRIC CODE IN CANADA OR THE CURRENT NATIONAL ELECTRIC CODE ANSI / NFPA NO. 70 IN THE UNITED STATES.

Important: Electrical box must be located within 10 feet of the burner(s) as the AC adaptor is 10 feet long and will not reach the DC supply wire connection if any farther.

The 4 AA batteries do not need to be installed if using the AC adaptor. The batteries would only be required in the event that 120V power is lost.

1. Remove the valve cover plate on side of unit to expose the DC supply wire by removing 6 screws

NOTE: The valve cover plate should be removed prior to being installed into the framing kit or framing in general for ease of access to these 6 screws. This would also apply when reinstalling the valve cover plate.

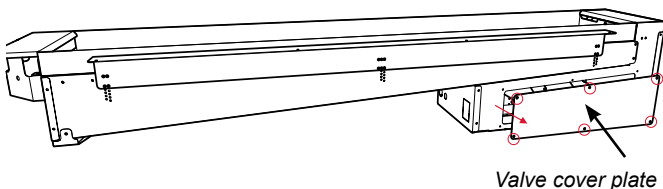

2. Locate the 'DC supply' wire on the wiring harness, the wire will be clearly marked.



AC adaptor

DC supply wire from wiring harness

3. Run the AC adaptor wire from the recently installed electrical box, to the back of the unit end, connect the AC Adaptor with the DC supply wire in the previous step.
4. Attach the AC adaptor to the DC supply wire. Secure wire using a strain relief (see enclosed picture) Reinstall the valve cover plate (reverse Step 2).
5. Plug the AC adaptor into a grounded fault interrupter (GFI) protected circuit.
6. Turn on gas and electrical supply and test unit.

INNER PANEL INSTALLATION

Before installation, panels must be handled and cleaned as per instructions noted below:
Stainless Steel Panels
<ul style="list-style-type: none"> Stainless panels must be inspected for scratches and dimples prior to installation. All claims to be recorded at this time. Claims for damage after installation will not receive consideration.
<ul style="list-style-type: none"> To protect the finish during installation and handling - cotton gloves MUST be worn at all times while handling the panels (even when removing protective coating).
<ul style="list-style-type: none"> Use a hair dryer or similar device to remove the protective coating from the panels.
<ul style="list-style-type: none"> Stainless panels will discolor a little during normal operation. This is normal and should not be considered a defect.
<p>* All hand and finger marks MUST be cleaned off with a soft cloth and a stainless steel cleaner. Most stainless steel cleaners leave a film/residue on the surface of the panels. Use an ammonia based cleaner (ie. glass cleaner) to remove this film before applying heat to the unit. Failure to do this will result in burn stains on panels which you will be unable to remove. Not protected by product warranty.</p>

1) Install the back panel first - to maneuver the panel into position - tilt the top of the panel forward and position the bottom of the panel in first. Use care - do not scratch the panel when clearing the pilot hood.



3) Install other side panel next. Position side panel and secure with a clip and one screw.



2) Install a side panel next (not important which side goes in first). Position the panel with the bend in the panel facing towards the outside or wall of the unit. Position side panel and secure with a clip and one screw.



4) Final install - shown below.



GLASS CRYSTAL INSTALLATION

Spread the Glass Crystals or Stones evenly over the burner. Ensure the crystals/stones do not overlap excessively as this will affect the flame pattern.

IMPORTANT NOTE:

Only the approved Glass Crystals and Stones are to be used with these fireplaces. Use of any other type of glass crystals or stones can alter the unit's performance, any damage caused by the use of any unapproved glass or stones will not be covered under warranty.

When using Ceramic Spa/Volcanic Stones DO NOT cover burner ports or pilot light that lead to pilot flame.

BURNER PACKAGES		
Unit	Glass Crystals	Stones - Spa / Ceramic / Volcanic
HZO42-11	3 lbs	3 lb Glass + 35 Volcanic stones



There are 2 optional packages to choose from to cover the firebox base:

- 1) Natural River Pebbles
- 2) Glass Crystals (4 colors available)

Spread the pebbles / crystals evenly on the exposed base of the firebox. Pebbles are **NOT** to be placed anywhere on the burner or over top of the Glass Crystals or optional Stones.

IMPORTANT NOTE: Only the supplied and approved pebbles / glass crystals are to be used with these fireplaces. Use of any other type of pebbles, glass crystals or other material can create a danger and will void the warranty.

Firebox (Around Burner) Packages		
Unit	Glass Crystals	Pebbles
HZO42	3 lbs	1 package (3 x bags pebbles)

VOLCANIC STONE INSTALLATION

Evenly spread the glass crystals and volcanic stones over the burner. Ensure the stones do not overlap too much as this will effect the flame pattern.

IMPORTANT NOTE:

Only the supplied approved Volcanic Stones are to be used with these fireplaces. Use of any other type of stones can alter the unit's performance, any damage caused by the use of any unapproved glass or stones will not be covered under warranty.

When using Volcanic Stones DO NOT cover burner ports or pilot light that lead to pilot flame. Ensure the stones do not overlap excessively as this will effect the flame pattern.

Do not add volcanic stones when using driftwood log set.

OUTDOOR VOLCANIC STONE BURNER PACKAGES		
Unit	Volcanic Stones Ivory/Tan	Volcanic Stones Slate/Grey
HZO42	35 stones w/3lbs glass	35 volcanic stones w/3lbs glass
NOTE: * Basalt Volcanic stones are measured by weight not quantity. Each bag contains 15lbs of stones, however the exact quantity and size will vary. Size varies between 2" - 3".		



Volcanic Stones Ivory /Tan + Glass Crystals



Volcanic Stones Slate /Grey + Glass Crystals

OPTIONAL LOG SET INSTALLATION

Installation of Reflective Panels must be completed before installing the log set.

Read the instructions below carefully and refer to the images. If the logs are broken do not use the unit until they are replaced. Broken logs can interfere with pilot operation. Install 3lbs of glass crystal or firebeads on the burner (follow glass crystal or firebeads instructions in unit manual) before installing logs.

Improper positioning of the logs may create carbon build-up and can alter the unit's performance which is not covered under warranty.

Log kit # 326-930 contains the following pieces:

Part #	Description
A x 1	Log
B x 1	Log
C x 1	Log
D x 1	Log
E x 1	Log
F x 1	Log

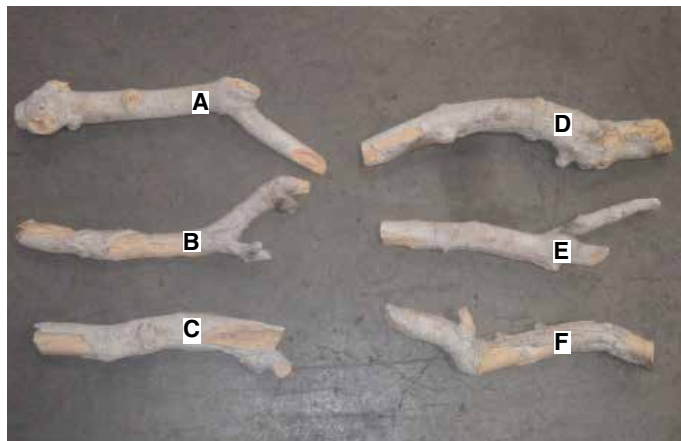

Diagram 1

- 1) Install Logs A and C on the burner as shown below. Orient the logs in the same way and in a similar location on the left side of the burner as depicted in Diagram 2.



Diagram 2

- 2) Install Log B on the burner as shown below. Orient Log B across Log A in the same way and in a similar position as depicted in Diagram 3.

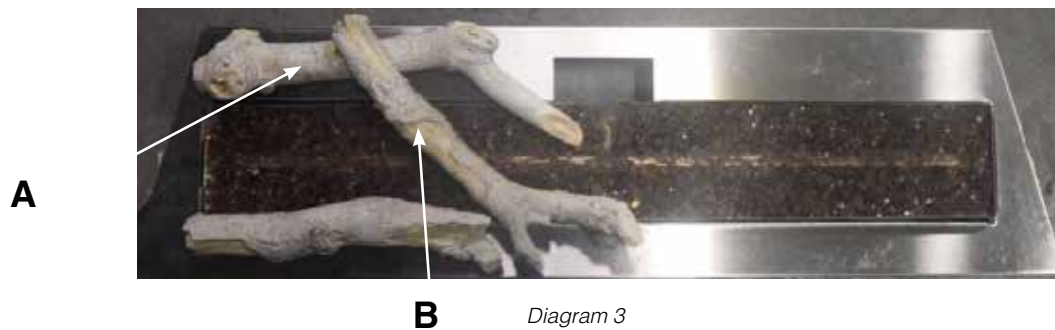

Diagram 3

- 3) Install Log E on the right side of the burner as shown below. Orient Log E in the same way and in a similar position as depicted in Diagram 4.



Diagram 4

- 4) Install Log D on the burner as shown below. Orient Log D across Log E in the same way and in a similar position as depicted in Diagram 5- Log D will rest up against the back panel.



Diagram 5

- 5) Install Log F on the right side of the burner as shown below. Orient Log F in the same way and in a similar position as depicted in Diagram 6.



Diagram 6

F



Final Install

WARNING: Failure to position the parts in accordance with these diagrams or failure to use only parts specifically approved with this appliance may result in property damage or personal injury.

HEAT DEFLECTOR INSTALLATION

- 1) Install the heat deflector to the top inside of the firebox with 4 screws as shown below.

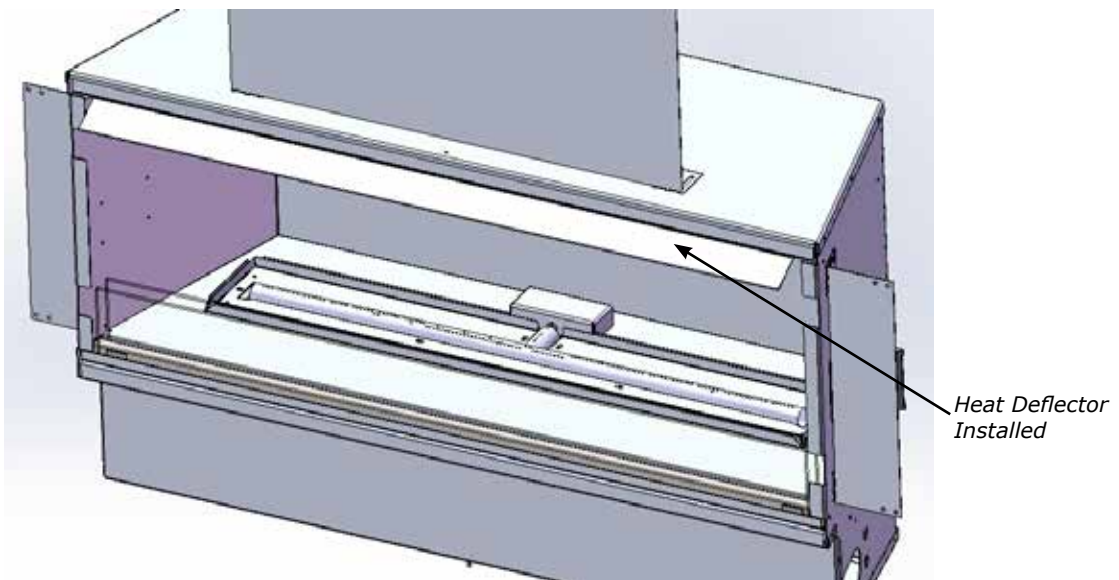
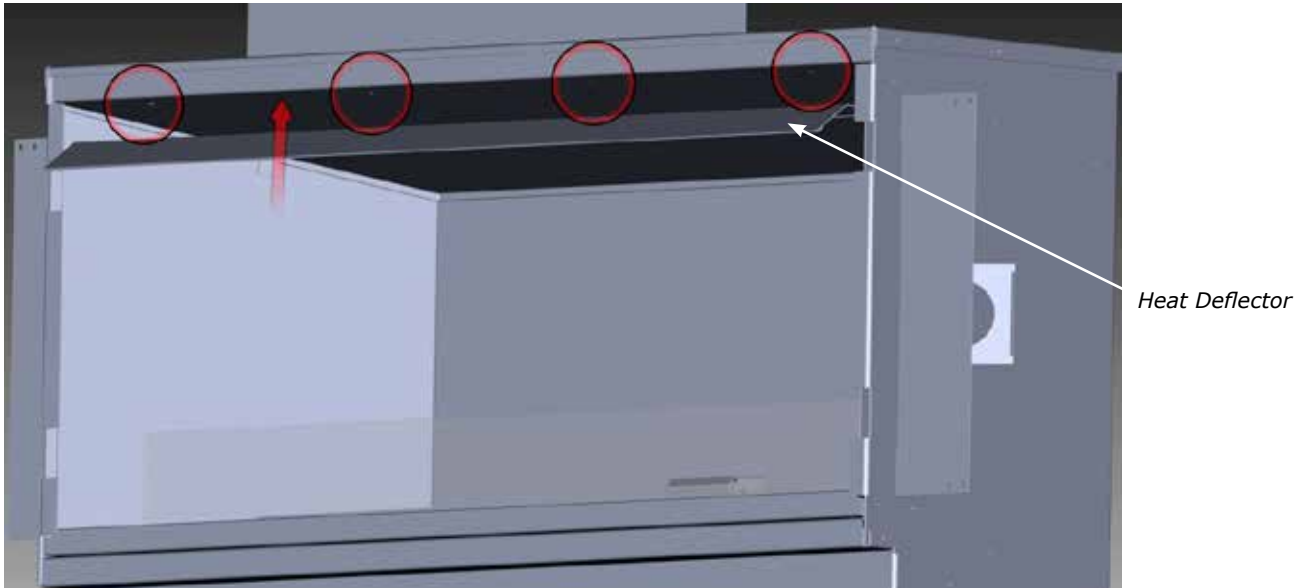

FACEPLATE INSTALLATION

Remove the protective coating from the faceplate before installation - see handling instructions in panel install section.

- 1) To install the faceplate - line up the tabs on the faceplate with the 'C' shaped openings on the left and right sides of the unit. There are 3 slots on each tab so the faceplate to accommodate different finishing materials.

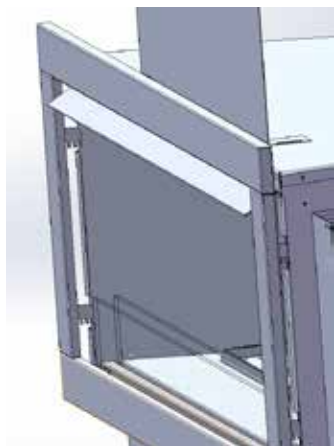
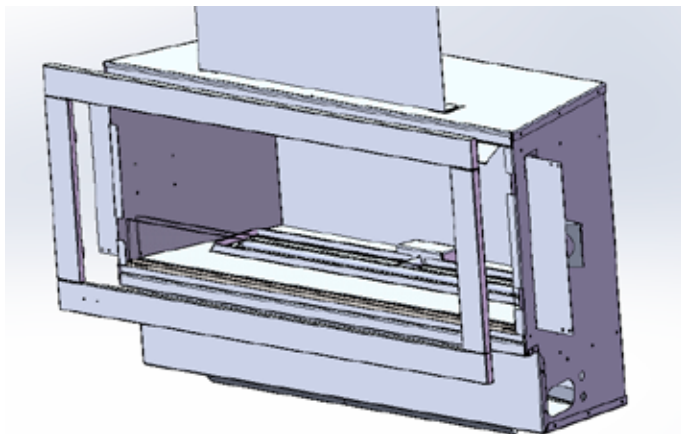

- 2) Install logo onto faceplate.

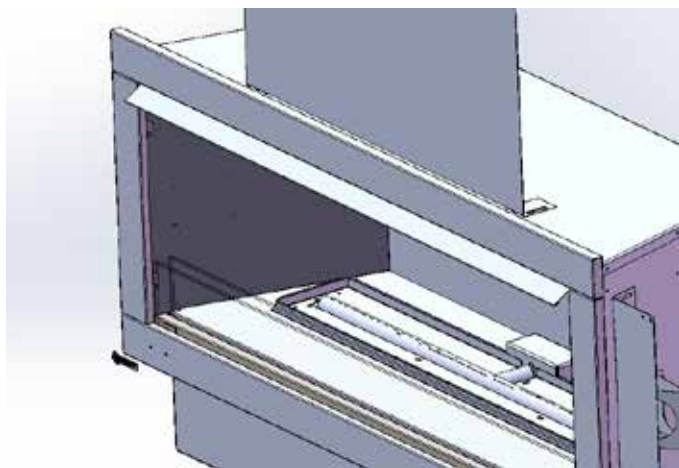

- 3) For installations where thicker finishing material is used - the optional trim piece may be installed to fill the gap. Install the trim between the bottom access panel and the faceplate as shown below.

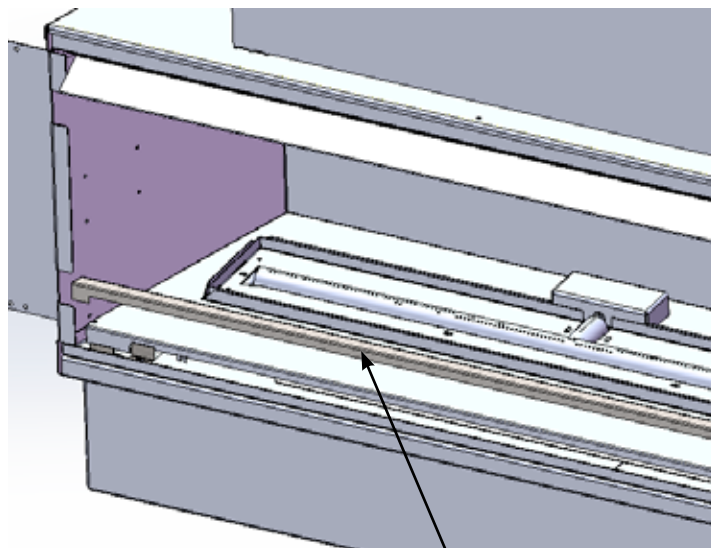

Trim Piece

- 4) To remove - reverse steps.

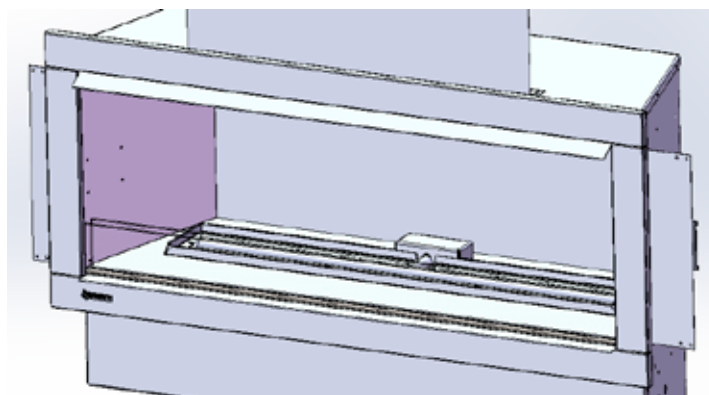

Final Install

GLASS WIND SHIELD INSTALLATION

- 1) To install the glass wind shield - slot it into the space between the burner tray cover and the bottom access panel.

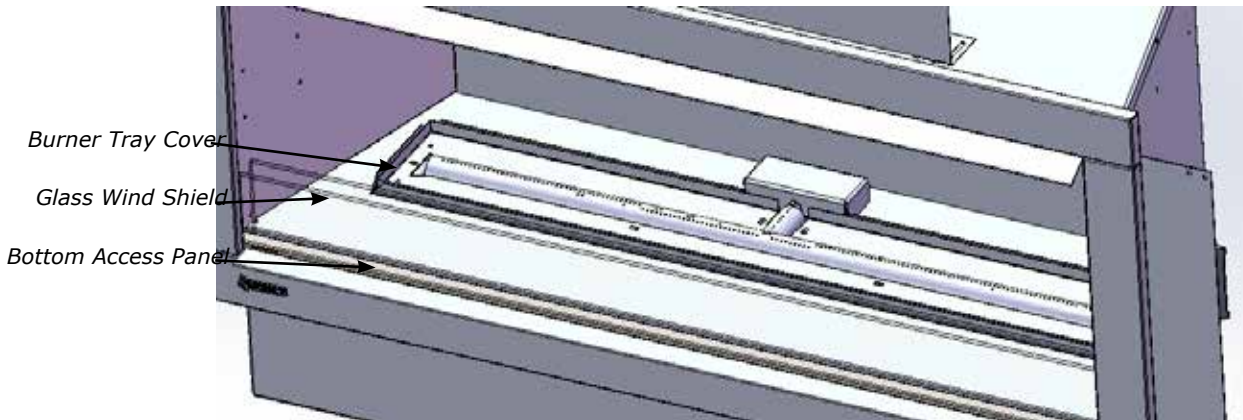

WEATHER COVER INSTALLATION / REMOVAL

- 1) The unit should be covered when not in use for extended periods of time. The soft fabric cover is made of weather resistant material - to protect the unit from the elements. Starting from one corner - slide the cover over the corner, then stretch the cover until it is fitted over all four corners.



CAUTION:
 Never start the unit with the cover on.
 Let the unit cool before installing the cover.
 Turn off gas supply to unit before installing cover.







Weather Cover Installed

ASSEMBLY INSTRUCTIONS FOR A STEEL STUD FRAMING KIT FOR HZO42

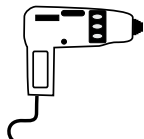
Follow these instructions to construct a steel stud frame for the Outdoor fireplace;
 Overall dimensions = 60" W x 20" D x 52-1/2" H.

**Non-combustible finishing board not supplied with kit. Board may be purchased at your local hardware/building supply store.

Tools Required	
1 power drill + #2 phillips bit	
1 hand #2 screwdriver (Phillips)	
1 level	
1 tape measure	

326-900 CONTENTS:	
Top / Bottom	(A) x 2
Vertical Supports - Tall	(B) x 8
Vertical Supports - Short	(C) x 6
Base	(D) x 1
Header	(E) x 1
Corner Brace	(F) x 2
Vertical Support	(G) x 1
Wafer Screws	80

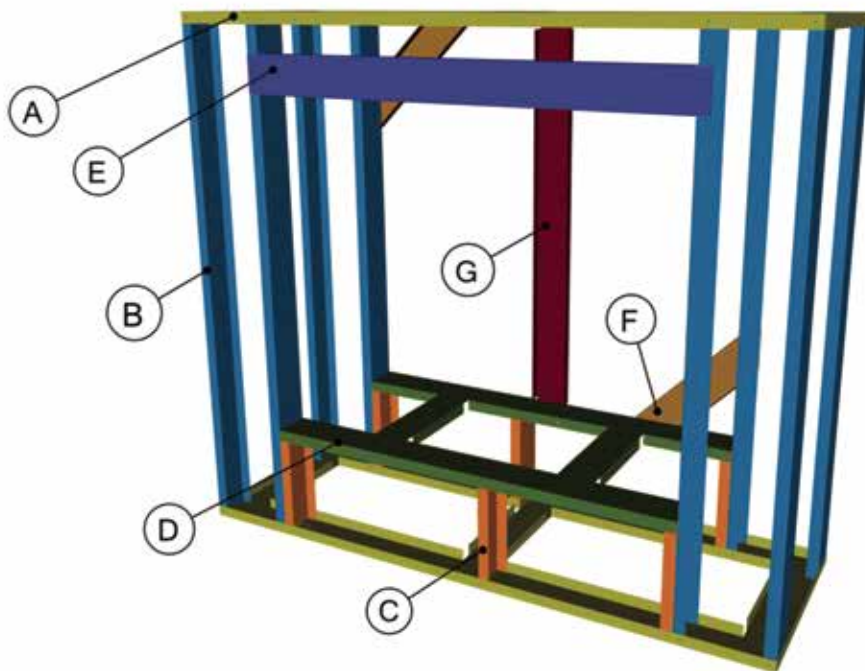

- 1) Place top/bottom (A) on the ground - flat side down. Bend the tabs up to a 90° angle.

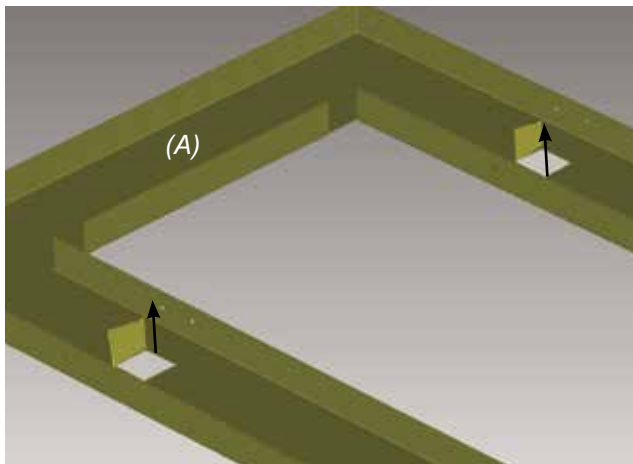

Bend tabs inward to 90° angle.

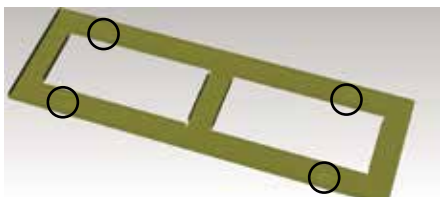

(A)
Tab locations

- 2) Position 4 of the (B) pieces with the flat side of (B) contacting the tab as shown below.

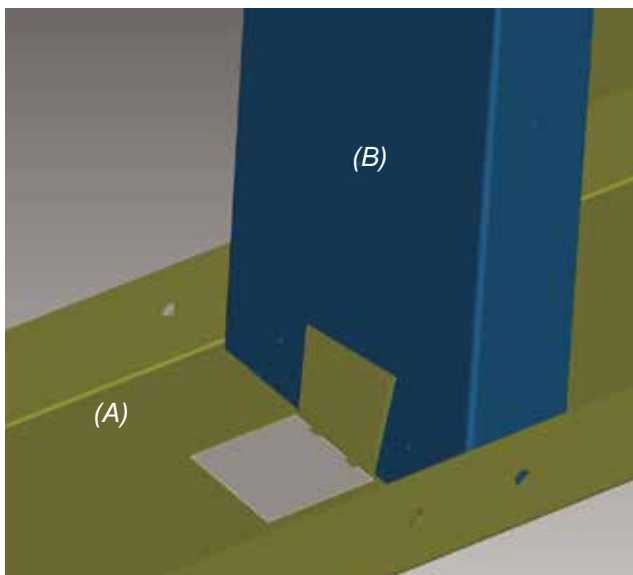

Part B positioned flat side flush with A tab.

- 3) Line up the screw holes of (A) with (B). Secure each (B) with 2 wafer screws (one on each side) as shown below.

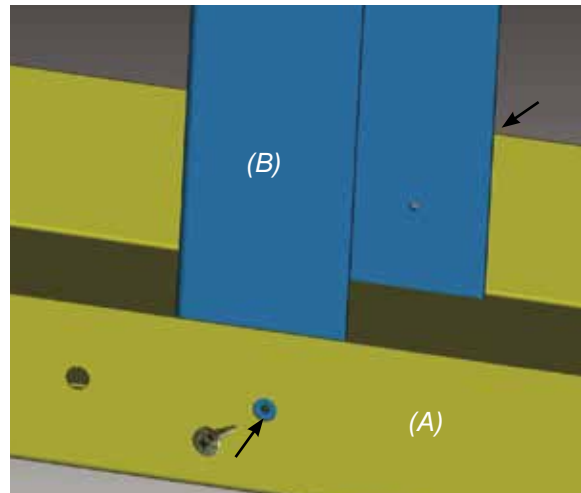

- 4) With all 4 - (B) pieces secured to the bottom with 2 screws (1 on each side) (A) can be placed into position, as shown below. Ensure all tabs on the (A) are bent to 90° and oriented to each (B) as shown in step 2.

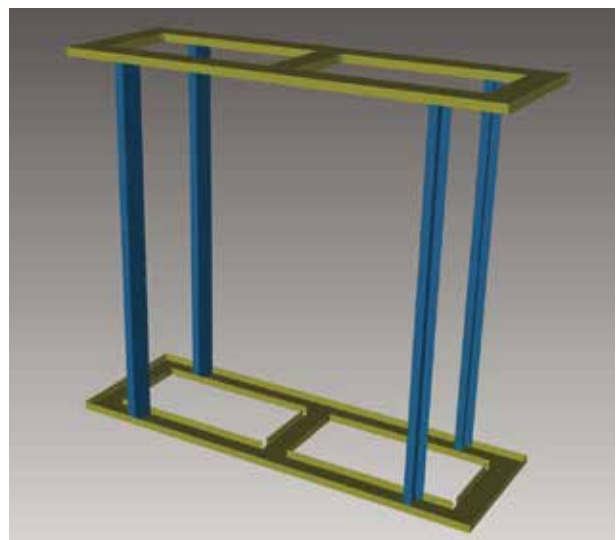

- 5) Line up top (A) screw holes with (B) screw holes and secure with (B) to (A) with 2 wafer screws (1 on each side - 8 in total).

Note: Securing inner (B) pieces to top (A) will add rigidity, making it easier to lineup and install outer (B) pieces.

Important: (B) - (tall vertical supports) must be positioned as shown to ensure the correct installation of (C).

36 | installation

6) Manoeuvre remaining (B) pieces and position in each corner of the frame - flat side facing out - see 2 diagrams below.

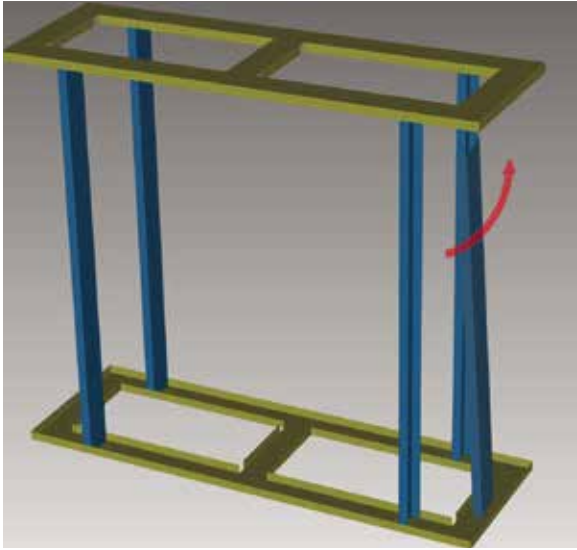

7) Line up screw holes on top / bottom (A) with each (B)- secure with 3 wafer screws each on top and bottom - 6 screws in total for each outer (B) (3 top- 3 bottom).

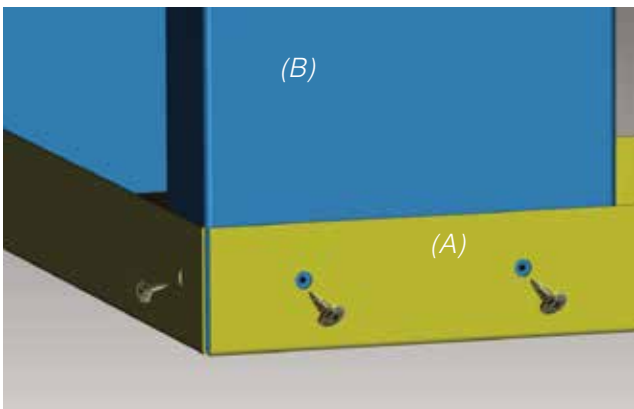

8) Position 4 - (C) pieces with the flat side back to back with the flat side of each inner Part B as shown below. Secure each (C) to bottom (A) with 3 wafer screws (one on each side and one at top as shown below).

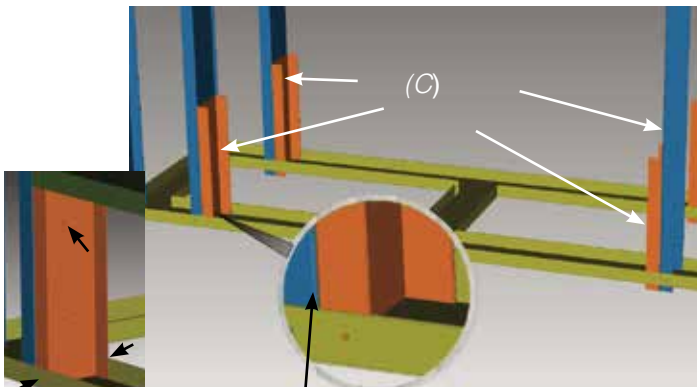

(C) Screw locations

(B)+ (C) - flat sides back to back

9) Position remaining 2 - (C) pieces offset from center rib as shown below.

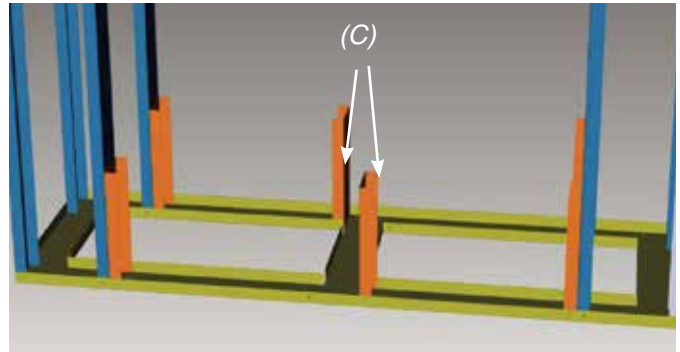

10) Position (D) on top of (C) pieces - line up screw holes and secure (D) to (C) with 12 wafer screws.

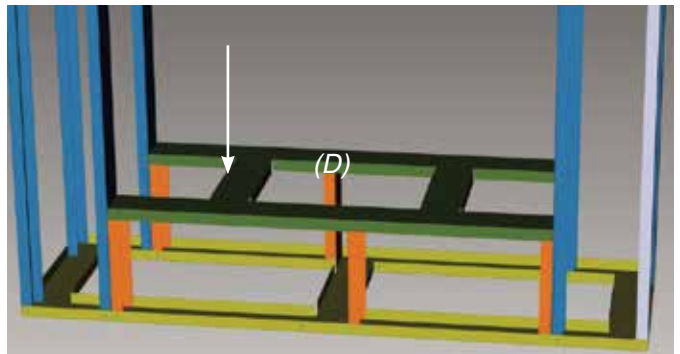

11) Measure 44-11/16" from floor (bottom of the header location) line up (E) (header) with appropriate screw holes.

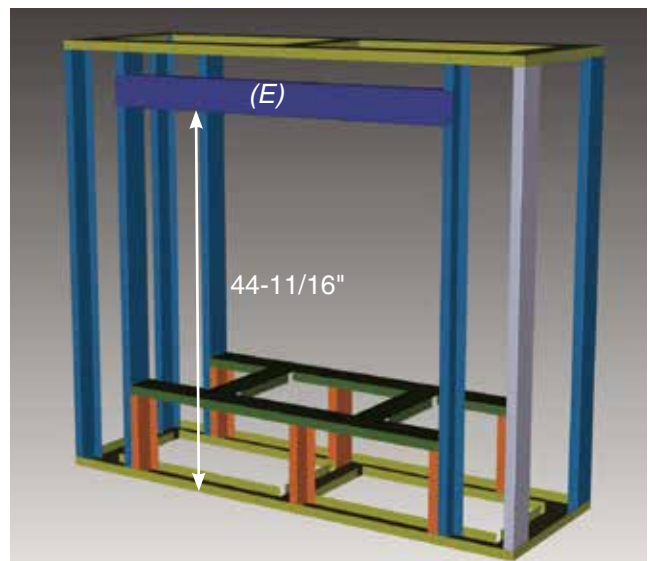

12) Line up screw holes on (E) (header) and (B) (inner vertical support). Secure with 2 wafer screws on each side (4 total) as shown below. This will now be the front of the frame.

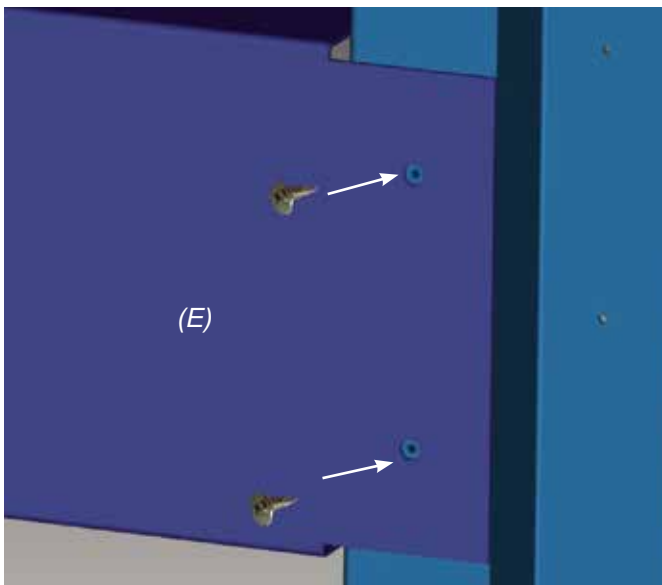

13) On the back side of the frame. Install both (F) pieces (corner brace) on opposite corners.

Important: (F) parts must be installed opposite from one another for rigidity as shown below.

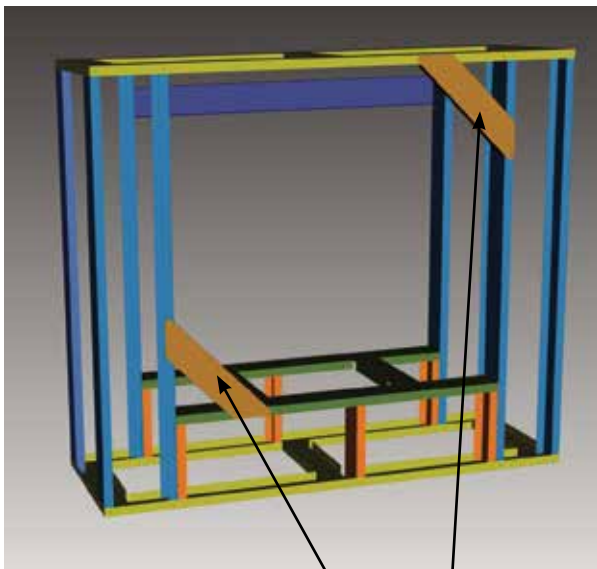

(F) corner brackets positioned in opposite corners

14) Line screw holes on 1 (F) (corner brace) with (B) + (A) and secure with 4 wafer screws. as shown below.

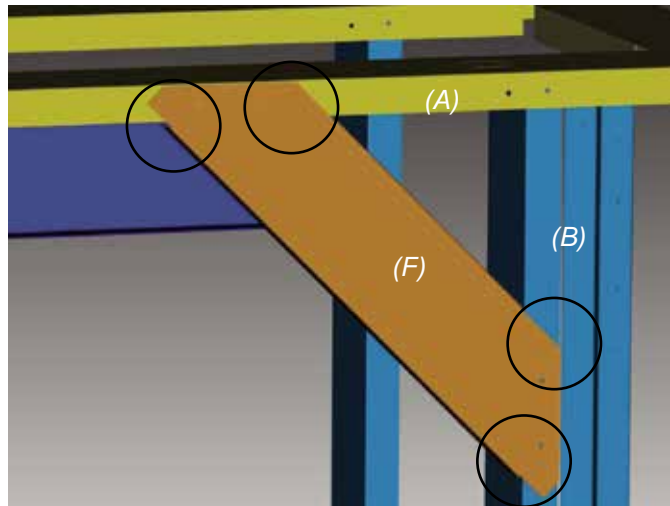

15) Repeat step 14 for opposite corner as shown below.

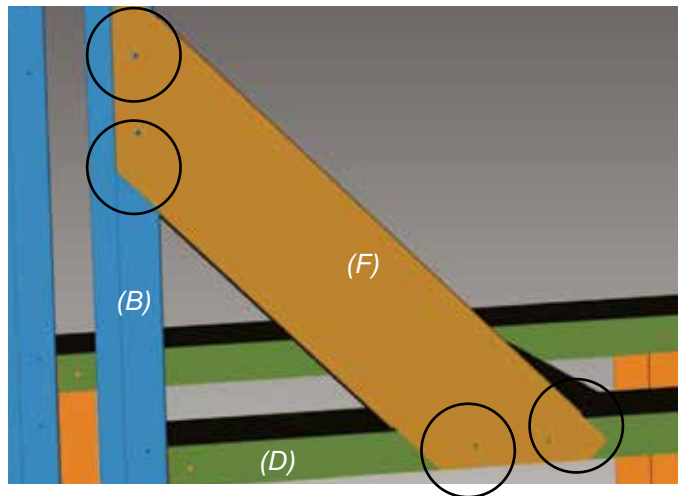

16) Install vertical back support to back of assembly with 2 screws at top and bottom in locations shown below.

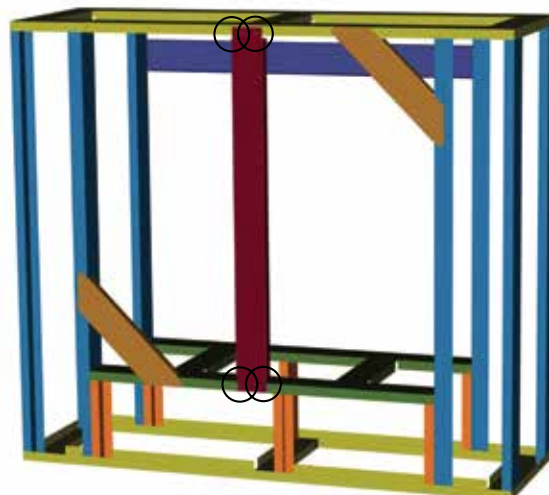

Note: Confirm assembly is level and square before proceeding with further materials.

OPERATING INSTRUCTIONS

- 1) Read and understand these instructions before operating this appliance.
- 2) Check to see that all wiring is correct and enclosed to prevent possible shock.
- 3) Check to ensure there are no gas leaks.
- 4) Ensure that the stainless panels are installed.
- 5) Verify log placement. If the pilot cannot be seen when lighting the unit, the logs have been incorrectly positioned.
- 6) The unit should never be turned off, and on again without a minimum of a 60 second wait.

LIGHTING PROCEDURE

- 1) Turn on ON/OFF switch.
- 2) After approximately 4 seconds the spark ignition system will spark for 60 seconds to light the main burner.
- 3) The unit will turn on.

Note: The first try for ignition will last approximately 60 seconds. If there is no flame ignition (rectification) the board will stop sparking for approximately 35 seconds. After wait time, the board will start second try for ignition by sparking for approximately 60 seconds. If there is still no positive ignition the board will go into lock out.

The system will need to be reset as follows:

- a) Turn the system off using ON/OFF switch.
- b) After approximately 2 seconds turn on ON/OFF switch.
- c) Unit will repeat step 2.

SHUTDOWN PROCEDURE

- 1) Turn ON/OFF switch.
- 2) If service is to be performed - you must disconnect both sources of power to the unit, the main power and battery.

FIRST FIRE

The first fire in your fireplace is part of the paint curing process. To ensure that the paint is properly cured, it is recommended that you burn your fireplace for at least four (4) hours the first time you use it.

When first operated, the unit will release an odour caused by the curing of the paint, the burning off of any oils remaining from manufacturing.

The glass panel may require cleaning after the unit has cooled down.

DO NOT ATTEMPT TO CLEAN THE GLASS WHILE IT IS HOT.

Note: When the glass is cold and the appliance is lit, it may cause condensation and fog the glass. This condensation is normal and will disappear in a few minutes as the glass heats up.

COPY OF LIGHTING PLATE INSTRUCTIONS

The lighting plate is located on the underside of the front access panel in the unit.

<p>FOR YOUR SAFETY READ BEFORE LIGHTING If none, follow the National Fuel Gas Code, ANSI Z223.1/NFPA 54, or local codes.</p> <p>WARNING: If you do not follow these instructions exactly, a fire or explosion may result causing property damage, personal injury or death.</p> <p>Information: For assistance or information on proper installation, service agency or gas supplier.</p> <p>AVERTISSEMENT: Quiconque ne respecte pas à la lettre les instructions de cet appareil, risque d'entraîner des dommages, des blessures ou la mort.</p> <p>Une installation, d'ajustement, de modification, de service ou de réparation doit être effectuée par un technicien qualifié. Consultez votre manuel de propriété ou les informations fournies avec cet appareil. Pour obtenir de l'aide ou des informations supplémentaires, contactez votre fournisseur de gaz.</p>	<p>A) This appliance is equipped with an ignition device which automatically lights the pilot.</p> <p>BEFORE OPERATING: Be sure to smell out for gas around the appliance area for gas. Be sure to smell out to the floor because some gas is heavier than air and will settle on the floor.</p> <p>WHAT TO DO IF YOU SMELL GAS:</p> <ul style="list-style-type: none"> - Do not touch any electric switch, do not use any phone in your building. - Immediately call your gas supplier from a neighbor's phone. Follow the gas supplier's instructions. - If you smell gas, stop trying to light the pilot and call your gas supplier. <p>A) Cet appareil est muni d'un dispositif d'allumage qui allume automatiquement la veilleuse.</p> <p>AVANT L'UTILISATION: Vérifiez attentivement l'absence de fuite de gaz autour de l'appareil.</p> <p>QUE FAIRE EN CAS DE FUITE DE GAZ:</p> <ul style="list-style-type: none"> - Ne touchez pas d'interrupteur électrique. - Ne tentez pas d'allumer l'appareil. - Appelez immédiatement votre fournisseur de gaz, depuis un voisin. Suivez les instructions du fournisseur. <p>- Si vous ne pouvez pas rejoindre le fournisseur de gaz, appelez le service incendie.</p>	<p>CAUTION: Burns may result. Do not allow children to touch. SAVE THESE INSTRUCTIONS</p> <p>Keep children, furniture, gasoline and other liquids away from burner and control panel area. See operating instructions for details.</p>	<p>LIGHTING INSTRUCTIONS</p> <p>STOP! Read the safety information on this label.</p> <ol style="list-style-type: none"> 1) Turn on ON/OFF switch. 2) After approximately 4 seconds the spark ignition system will start. 3) The unit will turn on. <p>Note: The first attempt to ignition will last approximately 60 seconds. If there is no flame ignition (rectification) the board will stop sparking for approximately 35 seconds. After this wait time, the board will start sparking again. If there is still no positive ignition after the second attempt the board will go into lock out.</p> <ol style="list-style-type: none"> a) Wait 5 minutes - to be reset as follows (after going into lock out mode): b) Turn the ON/OFF switch to the OFF position and wait 2 minutes. c) Unit will repeat step 2. 	<p>1) Appuyer sur l'interrupteur ON / OFF des appareils, le système d'allumage procède au démarrage du brûleur principal.</p> <p>2) Après environ 4 secondes, le système d'allumage des appareils allume les flammes pendant 60 secondes. Si l'allumage n'est pas réussi, le système fait une pause d'environ 35 secondes. Après ce délai, le système tente à nouveau d'allumer les flammes en produisant des étincelles pendant 60 secondes. Si l'allumage n'est toujours pas réussi, le système se met en mode verrouillage.</p> <ol style="list-style-type: none"> a) Attendre 5 minutes et réinitialiser l'appareil en réglant l'interrupteur sur «OFF». b) Attendre 2 minutes après avoir mis l'interrupteur sur «OFF». c) L'unité répétera l'étape 2. 	<p>TO TURN OFF GAS APPLIANCE</p> <ol style="list-style-type: none"> 1) Turn off ON/OFF switch. 2) After approximately 4 seconds the spark ignition system will start. 3) The unit will turn on. <p>Note: The first attempt to ignition will last approximately 60 seconds. If there is no flame ignition (rectification) the board will stop sparking for approximately 35 seconds. After this wait time, the board will start sparking again. If there is still no positive ignition after the second attempt the board will go into lock out.</p> <ol style="list-style-type: none"> a) Wait 5 minutes - to be reset as follows (after going into lock out mode): b) Turn the ON/OFF switch to the OFF position and wait 2 minutes. c) Unit will repeat step 2. 	<p>DO NOT REMOVE THIS INSTRUCTION PLATE</p>
--	---	--	---	--	---	--

MAINTENANCE INSTRUCTIONS

1. Always turn off the gas valve and unplug the batteries before cleaning. For relighting, refer to lighting instructions. Keep the burner and control compartment clean by brushing and vacuuming at least once a year. When cleaning the logs, use a soft clean paint brush as the logs are fragile and easily damaged.
2. Clean appliance with a damp cloth (never when unit is hot). Never use an abrasive cleaner. The glass should be cleaned with a gas fireplace glass cleaner.
3. Hand and finger marks should be cleaned off with a soft cloth and a stainless steel cleaner. Most stainless steel cleaners leave a film/residue on the surface of the panels. Use an ammonia based cleaner (ie. glass cleaner) to remove this film before applying heat to the unit. Failure to do this will result in burn stains on panels which you will be unable to remove.
4. The heater is finished in a heat resistant paint and should only be refinished with heat resistant paint. Regency® uses StoveBright Paint - Metallic Black #6309.
5. Make a periodic check of burner for proper position and condition. Visually check the flame of the burner periodically, making sure the flames are steady; not lifting or floating. If there is a problem, call a qualified service person.
6. The appliance must be inspected before use, and at least annually, by a qualified field service person, to ensure that the flow of combustion and ventilation air is not obstructed.
7. Do not use this appliance if any part has been under water. Immediately call a qualified service technician to inspect the appliance and to replace any part of the control system and any gas control which has been under water. This is not covered under the terms of the warranty policy.
8. Verify operation after servicing.

VALVE ASSEMBLY REPLACEMENT

1. Turn the unit off and allow it to cool down to room temperature.
2. Turn off the gas supply to the unit.
3. Remove trim.

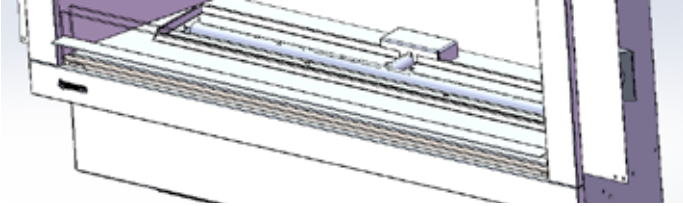

4. Remove the faceplate by lifting it up and off the unit.

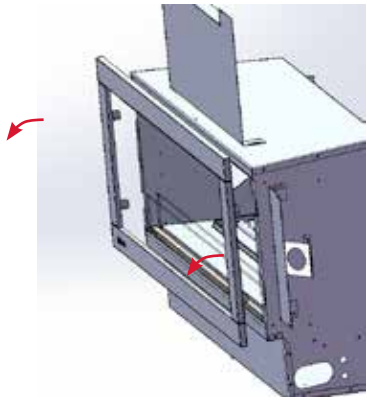

5. Remove the glass wind shield by lifting it up and out- place on a soft surface.

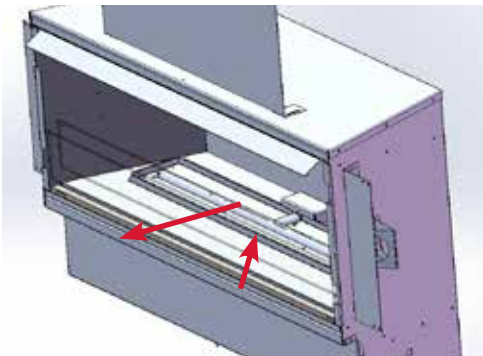

6. Remove the screw and panel clip on the right side. Remove the right side panel once the clip has been removed.



7. Remove the screw and panel clip on the left side. Remove the left side panel once the clip has been removed.

8. Remove the back panel once the 2 side panels have been removed.

9. Remove the front access panel by lifting up and out.

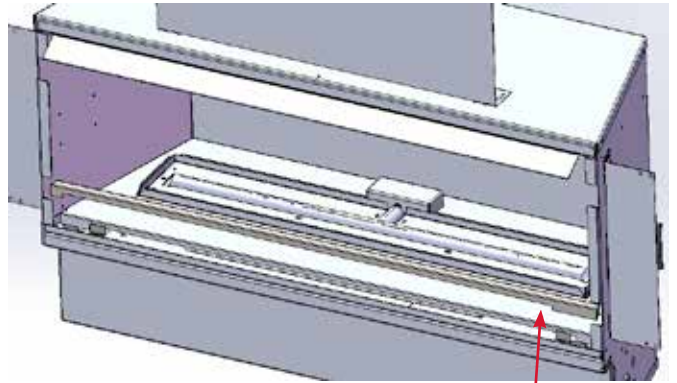

10. Remove the burner tray by lifting up and out.

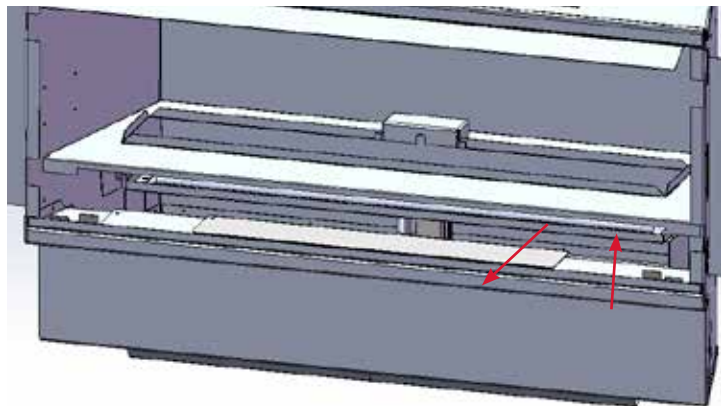

11. Remove left and right screws from the burner legs.



42 | maintenance

- 12) Slide the burner to the right and lift up and out of the firebox.



- 13) Remove 6 screws in locations shown below to access DFC.



- 14) Remove 6 screws and lift out valve tray.



- 15) Replace with new valve tray and reverse steps. Inspect gasket condition, replace if necessary.

DIGITAL FIREPLACE BURNER CONTROL REMOVAL

1. Remove 6 screws in locations shown below to access DFC.

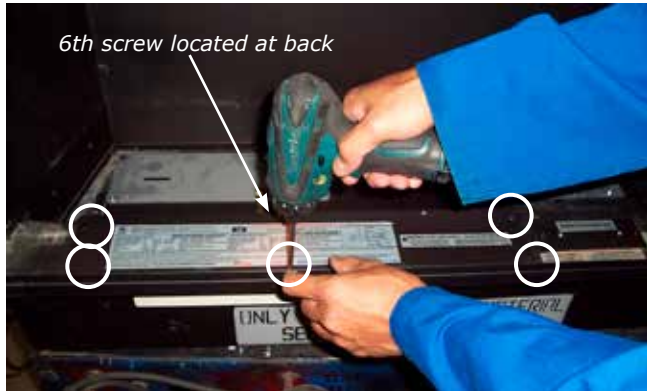

2. Remove the DFC from the floor of the firebox by removing 2 screws in locations shown below to release DFC bracket.

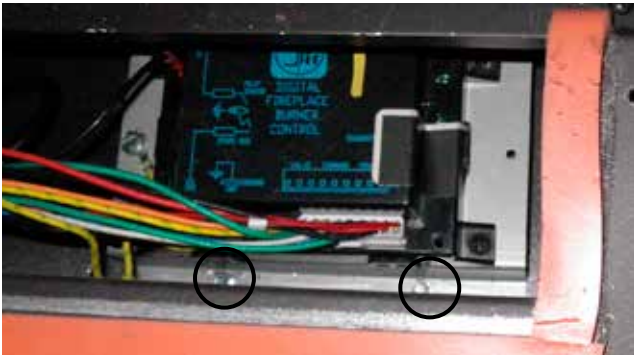

3. Disconnect the Black Pilot sensor wire with Red Spade connector from the 'ON' on DFBC (Digital fireplace burner control) box. See Diagram 1 below.



Pilot Sensor Wire

Diagram 1

4. Disconnect the Black sparker wire with black spade connector from CN3. See Diagram 2 below.

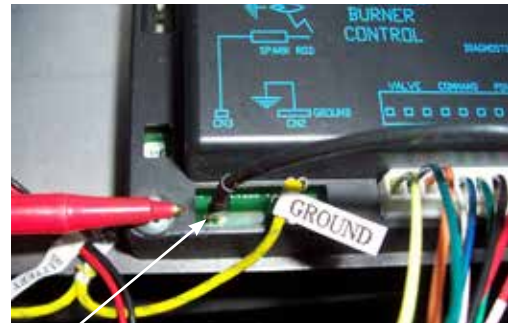

Sparker Wire

Diagram 2

5. Disconnect the white and green On/Off switch wires. See Diagram 3 below.

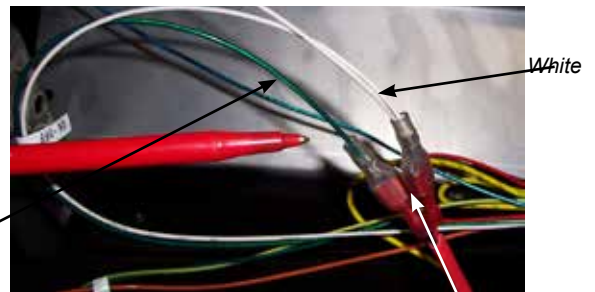

Green

White

Diagram 3

ON/OFF wires

6. Disconnect the yellow ground wire with green diagonal stripe for pilot (CN2). See Diagram 4 below.

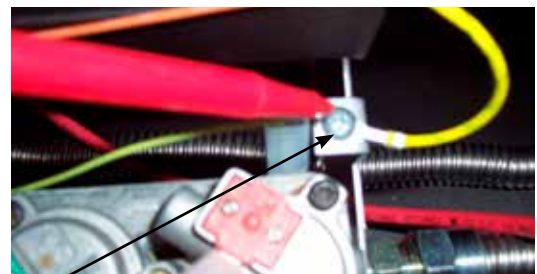

Ground wire

Diagram 4

7. Disconnect the three valve wires (yellow wire with green stripe). See Diagram 5 below.

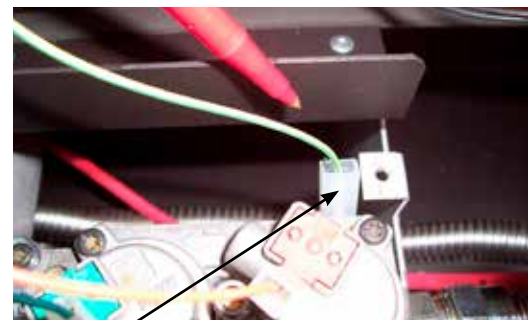

Valve wire

Diagram 5

GAS MAINTENANCE - RECOMMENDED ANNUAL ROUTINE

In order for your Regency appliance to continue to provide comfort to your home periodic maintenance must be performed to ensure it is operating at peak efficiency. The items in the list should be checked by a licensed gas service technician during the annual service check. Your unit may require more frequent maintenance checks if you notice any changes in how it operates. Operational changes to look for can include, but are not limited to, extended start up time, increased fan noise, residue/carbon build up, white build up on the glass/firebox, increased operating noise etc. Should any of these or other conditions arise, discontinue use and schedule a service check with your local licensed gas technician. The list below shows items your licensed service technician will need to check and service at least annually.

Clean

- Glass
- Interior bricks / panels
- Burner ports & burner air shutter
- Fan blades
- Log set
- Pilot orifices
- Pilot hood (change as needed)
- Flame sensor (electronic ignition models)
- Flame electrode
- Burner orifice
- Thermocouple (millivolt models)
- Thermopile (millivolt models)

Inspect

- Pilot assembly
- Burner
- Pressure relief gaskets/doors
- Flue connector gasket if present
- Door seal
- Firebox
- Venting
- Batteries (remote handheld, remote receiver, DC sparker, change as needed)
- Burner media (change as needed)
- Air shutter setting
- Wiring

Check

- Voltage on thermocouple/thermopile (millivolt models)
- Ohms reading on flame sense (electronic ignition models)
- Inlet/outlet fuel pressures as per rating plate
- Voltage/ohms readings on gas valve
- Ohms reading to on/off switch circuit (Millivolt models)

Gas Leak Tests

- Check main gas line connection to valve
- Check shut off valve connections
- Check connection at gas valve outlet
- Check connection at main burner orifice
- Check pilot fuel line at valve and at pilot assembly

MAIN ASSEMBLY

Part #	Description
1	326-552 2" Faceplate assembly
2	326-009 Heat Deflector
3	326-066 Filler Trim
4	948-223 Regency Logo Plate
5	326-038 Clip Glass (Brushed SS) (Each)
7	326-103 Front access panel
8	326-101 Burner Tray Cover
9	326-054 Perforated Pilot Hood
*	911-013 Valve Wiring Harness
*	911-019 Wiring from Burner To On/Off Switch
*	911-018 Holder Battery W/9V Snap 4 Cell Stack AA
*	911-086 Wire 9 Volt Battery Extension
*	911-087 Double Gang Front Cover
*	911-088 Double Gang Box Grey
*	904-658 Inlet Flex Line Gas SS Steel 24 inch
*	846-698 Gasket Silicone Sponge 3/16" x 1/2" (12')
*	Part Not Shown

Part #	Description
10	326-036 Top nailing strip
11	326-037/F Side nailing strip
12	940-533/P Glass Windshield (Each)
*	911-265 (DFC) Digital Fireplace Control
*	910-363 Wall Switch
*	377-060 Upper Vent (Each)
*	377-061 Lower Vent (Each)
*	911-087 Double Gang Box Cover
*	911-088 Double Gang Box
*	326-940 Seasonal Weather Cover
	920-274 Manual
*	Part Not Shown

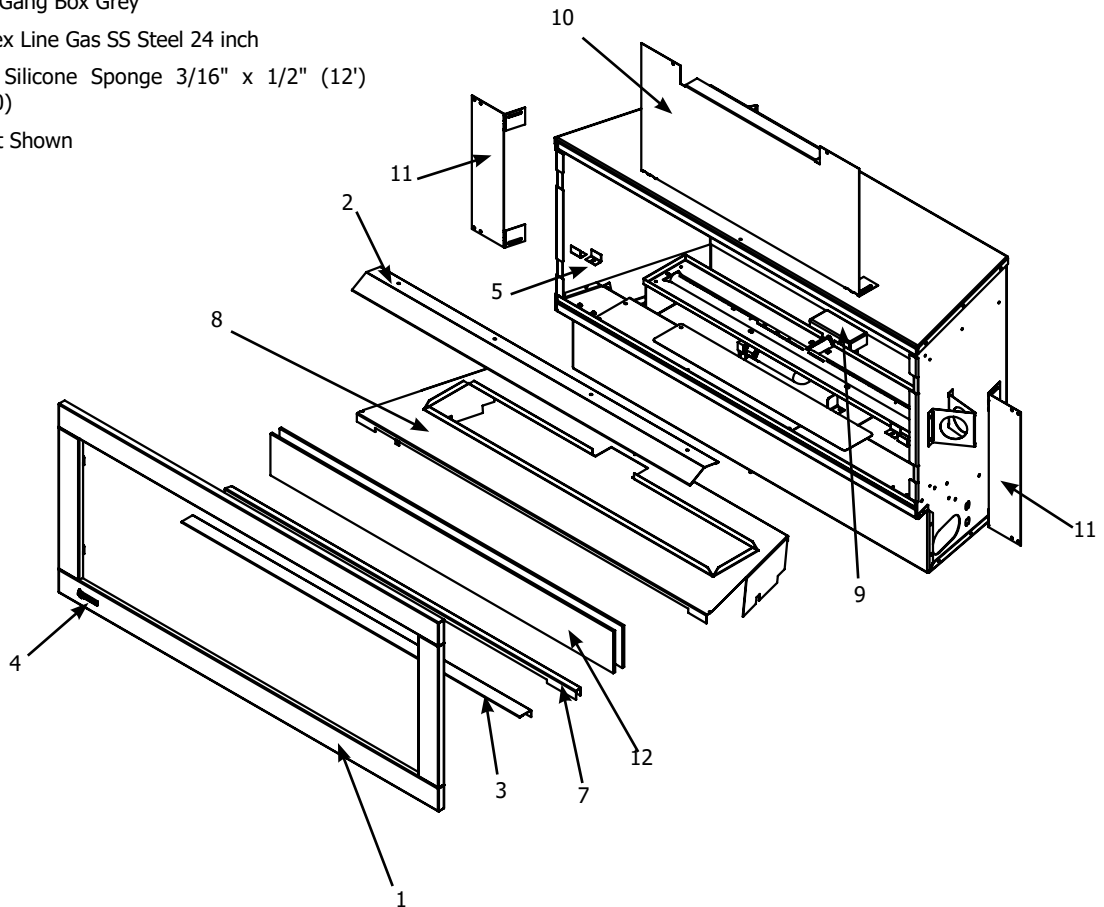

BURNER ASSEMBLY

Part #	Description	Part #	Description
9) 326-525	Burner Assembly NG-LP	14) 904-777	Burner Orifice #29 NG
10) 327-574/P	Valve Assembly - NG	904-434	Burner Orifice #47 LP
10) 327-576/P	Valve Assembly - LP	15) 326-028	Pilot Shield
N/S 910-036	Pilot Orifice - NG	16) 326-527	Burner Tray with Legs
N/S 910-101	Pilot Orifice - LP	N/S 910-432	Pilot Tubing/Including Fittings
N/S 911-039	2 Way Pilot Hood		
N/S 911-137	Pilot Hood Clip		
11) 326-101	Burner Tray Cover		
12) 911-276	Pilot Assembly - NG		
911-007	Pilot Assembly - LP		
911-037	Flame Sensor		
911-038	Spark Electrode		
13) 911-024	Gas Valve - NG		
911-025	Gas Valve - LP		

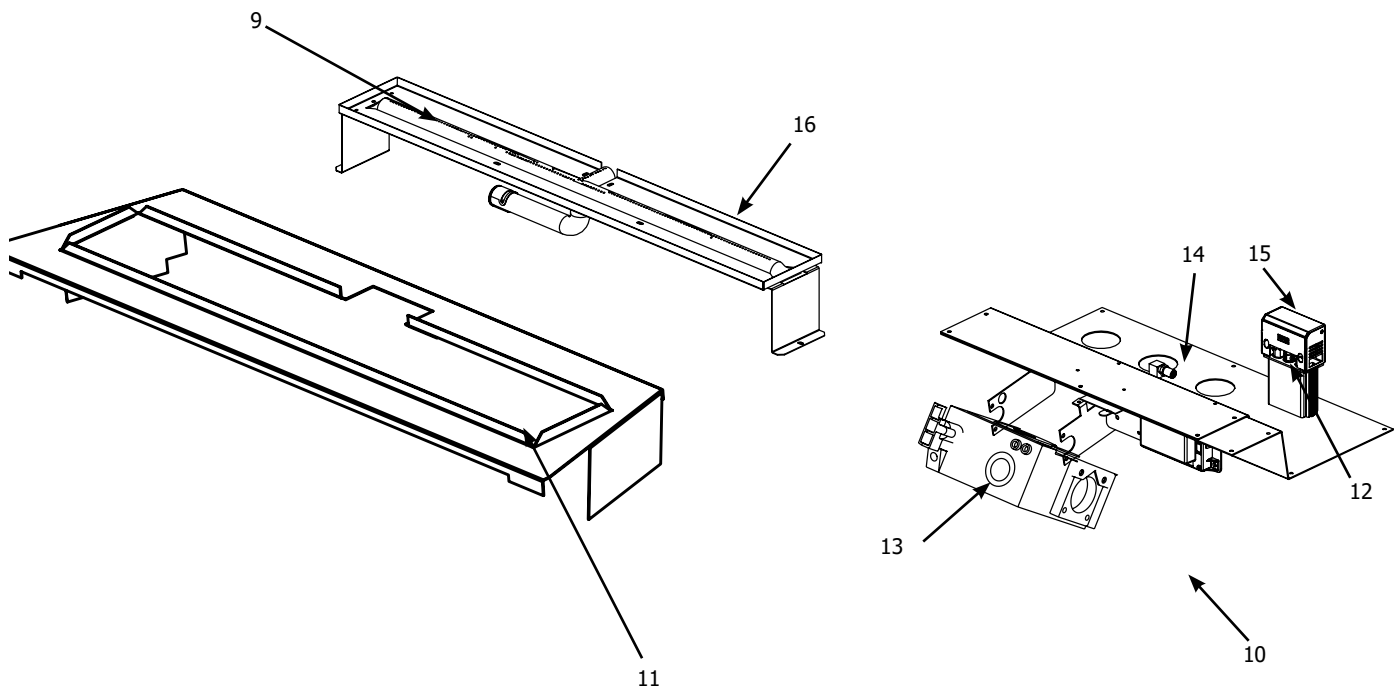

Part #	Description
1) 326-021	Panel Rear (Brushed Stainless)
2) 326-022	Panel Left (Brushed Stainless)
3) 326-023	Panel Right (Brushed Stainless)
4) 326-552	Faceplate Brushed Stainless
* 326-034	Clip Inner Panel HZO42 (Brushed SS) (Each)

ACCESSORIES

Part #	Description
946-675	Black Glass Crystals (1 Pound)
946-676	Copper Glass Crystals (1 Pound)
946-677	Starfire Glass Crystals (1 Pound)
946-735	Black Firebeads (1 Pound)
946-737	Glacier Ice Firebeads (1 Pound)
946-738	Caramel Luster Firebeads (1 Pound)
946-710	Slate/Grey Volcanic Stones
946-711	Ivory/Tan Volcanic Stones
946-672	Natural River Pebbles
326-930	Ceramic Log Set
646-950	Hardware Kit
326-900	Steel Framing Kit

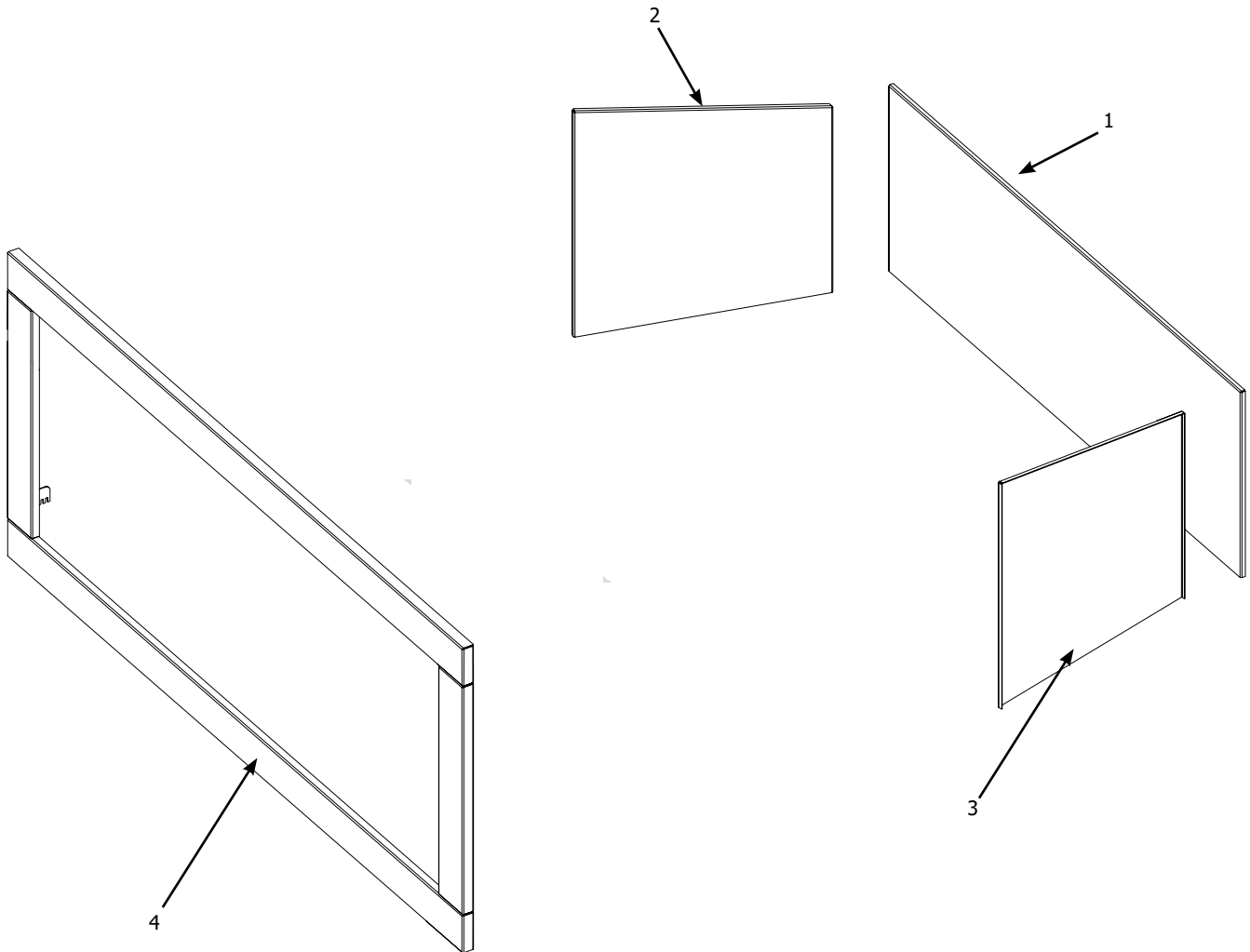

Outdoor Gas Product Warranty

Limited Warranty

FPI Fireplace Products International Ltd. (for Canadian customers) and Fireplace Products US, Inc. (for US customers) (collectively referred to herein as “FPI”) extends this Limited Warranty to the original purchaser of this Appliance provided the product remains in the original place of installation. The items covered by this Limited Warranty and the period of such coverage are set forth in the table below.

An Appliance in this policy is defined as an Outdoor Gas Burner, Outdoor Gas Fireplace, Outdoor Gas Table.
This Appliance has only been certified and listed for use outdoors.

Some conditions apply (see below).

This Limited Warranty starts on the day the Appliance was purchased.
The Limited Warranty is not transferable, amendable or negotiable under any circumstances.

Outdoor Gas Products	Component Coverage		Subsidized Labor Coverage*
	2 years	1 year	1 year
Burner tube assembly Valve assembly Pilot assembly Flame sensor/Spark electrode	✓		✓
Ignition Control Boards	✓		✓
Wiring/Switches/Battery Pack/Batteries	✓		✓
Pilot Tube/Burner and Pilot Orifices	✓		✓
All hardware including wheels and rubber feet	✓		✓
Weather covers	✓		✓
Thermocouple		✓	✓
Electrical components		✓	✓
Tempered Glass		✓	✓
All media		✓	✓
Stainless components/ Paint/Gaskets/ All finishes/Plated Corners			
Fireboxes (defect in manufacture)	✓		✓

Note: Warranty coverage noted above may not be applicable as components/options vary based on appliance purchased.

Conditions:

Warranty protects against defect in manufacture or FPI factory-assembled components only, unless herein specified otherwise.

***This warranty does not cover dealer travel costs, mileage, fuel, tolls for diagnostic or service work. All labor rates paid to authorized dealers are subsidized, pre-determined rates. Dealers may charge you for travel and additional time beyond their subsidy.**

Any part(s) found to be defective during the warranty period as outlined above will be repaired or replaced at FPI’s option through an accredited distributor, dealer or pre-approved and assigned agent provided that the defective part

is returned to the distributor, dealer or agent for inspection if requested by FPI. Alternatively, FPI may, at its own discretion, fully discharge all of its obligations under warranty by refunding the verified purchase price of the product to the original purchaser. The purchase price must be confirmed by the original Bill of Sale.

The authorized selling dealer, or an alternative authorized FPI dealer if pre-approved by FPI, is responsible for all in-field diagnosis and service work related to all warranty claims. FPI is not responsible for results or costs of workmanship of unauthorized FPI dealers or agents in the negligence of their service work.

At all times, FPI reserves the right to inspect reported in the field/on location complaints of products claimed to be defective before processing or authorizing any claim. Failure to allow this upon request will void the warranty.

All warranty claims must be submitted by the dealer servicing the claim, including a copy of the Bill of Sale (proof of purchase by you). All claims must be complete and provide full details as requested by FPI to receive consideration for evaluation. Incomplete claims may be rejected.

Replacement Appliances to the original purchaser are limited to one per warranty term.

The Appliance must be installed according to all manufacturers' instructions as per the manual. All Local and National required codes must be met.

The installer is responsible for ensuring the Appliance is operating as designed at the time of installation.

The original purchaser is responsible for the annual maintenance of the Appliance, as outlined in the owner's manual. As outlined below, the warranty may be voided due to problems caused by a lack of maintenance.

Purchased parts: Repair/replacement parts purchased by the consumer from FPI after the original coverage has expired on the Appliance will carry a **90-day** warranty from the purchase date, valid with a receipt only. Any item shown to be defective will be repaired or replaced at our discretion. No labor coverage is included with these parts.

If freight damage has been found either externally or internally, the dealer must be informed within 3 days. All claims as a result of damage must be submitted by the dealer servicing the claim, including a copy of the Bill of Sale (proof of purchase). All claims must be complete and provide full details as requested by FPI to receive consideration for evaluation. **Incomplete claims may be rejected.**

As this is a **2-year** Limited Warranty, if the Appliance needs to be replaced, the Appliance that was purchased at the time of sale might not be replaced with exactly the same model Appliance. In that case, FPI will replace your Appliance with one that is similar at the time of replacement under the terms of this Limited Warranty, but **ONLY** in the event that an item covered by the Limited Warranty is found to be defective. Please refer to the table on first page of this warranty for items covered by the Limited Warranty. Product changes might be the result of the original Appliance being discontinued, changes in regulatory requirements, product advancements, etc., which are beyond the control of FPI. **This Limited Warranty does not cover any installation costs, or costs associated with changes of required clearances for the replacement Appliance, hearth pads, mantles, facing and/or facing materials such as framing, completed walls made of drywall, wood, non-combustible board, tile, brick, stone, marble etc., venting/chimney systems, or components of the chimney system.**

If a suitable replacement is not available, FPI will refund **50%** of the purchase price of the Appliance and any applicable FPI accessories (faceplates, panels, media, etc.) purchased at the time of sale. **In no event will FPI refund any portion of the purchase price of, or reimburse costs associated with, any other items, including without limitation, installation of a new Appliance, changes of required clearances for a new Appliance, hearth pads, mantles, facing and/or facing materials such as framing, completed walls made of drywall, wood, non-combustible board, tile, brick, stone, marble etc., venting/chimney systems, or components of the chimney system. A copy of the receipt or bill of sale will be necessary to validate the purchase price.**

Exclusions:

This Limited Warranty does not extend to paint, rust or corrosion of any kind due to a lack of maintenance or improper venting, combustion air provision, corrosive chemicals (i.e. chlorine, salt, air, etc.), door or glass gasketing, or any other additional factory fitted gasketing, batteries, color fading, carbon/sooting of the log sets due to use.

Malfunction, damage or performance-based issues as a result of environmental conditions, location, chemical damages, downdrafts, installation error, an installation by an unqualified installer, incorrect chimney components (including but not limited to cap size or type), operator error, abuse, misuse, use of improper fuels, lack of regular maintenance and upkeep, acts of God, weather-related problems from hurricanes, tornados, earthquakes, floods, lightning strikes/bolts or acts of terrorism or war, which result in a malfunction of the Appliance are not covered under the terms of this Limited Warranty.

FPI has no obligation to enhance or modify any Appliance once manufactured (i.e. as products evolve, field modifications or upgrades will not be performed on existing Appliances).

This warranty does not cover dealer travel costs, mileage, fuel, tolls for diagnostic or service work. All labor rates paid to authorized dealers are subsidized, pre-determined rates. Dealers may charge you for travel and additional time beyond their subsidy.

Any Appliance showing signs of neglect or misuse will not be covered under the terms of this warranty policy and may void this warranty. This includes Appliances with rusted or corroded fireboxes that have not been reported as rusted or corroded within **three (3)** months of installation/purchase.

Appliances which show evidence of being operated while damaged, or with problems known to the purchaser and causing further damages will void this warranty.

Appliances where the serial no. has been altered, deleted, removed or made illegible will void this warranty.

Minor movement, expansion, and contraction of the steel is normal and is not covered under the terms of this warranty.

Freight damages for products or parts are not covered under the terms of the warranty.

Products made or provided by other manufacturers and used in conjunction with the FPI Appliance without prior authorization from FPI may void this warranty.

Limitations of Liability:

The original purchaser's exclusive remedy under this warranty, and FPI's sole obligation under this Limited Warranty, express or implied, in contract or in tort, shall be limited to replacement, repair, or refund, as outlined above. IN NO EVENT WILL FPI BE LIABLE UNDER THIS WARRANTY FOR ANY INCIDENTAL OR CONSEQUENTIAL COMMERCIAL DAMAGES OR DAMAGES TO PROPERTY. TO THE EXTENT PERMITTED BY APPLICABLE LAW, FPI MAKES NO EXPRESS WARRANTIES OTHER THAN THE WARRANTY SPECIFIED HEREIN. THE DURATION OF ANY IMPLIED WARRANTY IS LIMITED TO DURATION OF THE EXPRESSED WARRANTY SPECIFIED ABOVE. IF IMPLIED WARRANTIES CANNOT BE DISCLAIMED, THEN SUCH WARRANTIES ARE LIMITED IN DURATION TO THE DURATION OF THIS WARRANTY.

Some US states do not allow limitations on how long an implied warranty lasts, or allow exclusion or limitation of incidental or consequential damages, so the above limitations or exclusions may not apply to you.

Customers located outside the US should consult their local, provincial or national legal codes for additional terms that may apply to this warranty.

How to Obtain Warranty Service:

Customers should contact the authorized selling dealer to obtain warranty service. In the event the authorized selling dealer is unable to provide warranty service, please contact FPI by mail at the address listed below. Please include a brief description of the problem and your address, email, and telephone contact information. A representative will contact you to make arrangements for an inspection and/or warranty service.

Canadian Warrantor:

FPI Fireplace Products International Ltd.

6988 Venture St.
Delta, British Columbia
Canada, V4G 1H4

USWarrantor:

Fireplace Products U.S., Inc.

PO Box 2189 PMB 125
Blaine, WA
United States, 98231

Or contact the Regency Customer Care Centre at 1-800-442-7432 (phone) /604-946-4349 (fax) / customerservice@regency-fire.com (e-mail)

Product Registration and Customer Support:

Thank you for choosing a Regency Fireplace. Regency strives to be a world leader in the design, manufacture, and marketing of hearth products. To provide the best support for your product, we request that you complete a product registration form at <http://www.regency-fire.com/Customer-Care/Warranty-Registration.aspx> within **ninety (90)** days of purchase.

Warranty Registration Card



Product Registration and Customer Support:

Thank you for choosing a Regency Fireplace. Regency strives to be a world leader in the design, manufacture, and marketing of hearth products. To provide the best support for your product, we request that you complete a product registration form found on our Web Site under Customer Care within ninety (90) days of purchase.

For purchases made in **CANADA or the UNITED STATES:**

<http://www.regency-fire.com/Customer-Care/Warranty-Registration.aspx>

For purchases made in **AUSTRALIA:**

<http://www.regency-fire.com.au/Customer-Care/Warranty-Registration.aspx>

You may also complete the warranty registration form below to register your Regency Fireplace Product and mail and/or fax it back to us, and we will register the warranty for you. It is important you provide us with all the information below in order for us to serve you better.

Warranty Registration Form (or Register online immediately at the above Web Site):

Warranty Details	
Serial Number (required):	
Purchase Date (required) (mm/dd/yyyy):	
Product Details	
Product Model (required):	
Dealer Details	
Dealer Name (required):	
Dealer Address:	
Dealer Phone #:	
Installer:	
Date Installed (mm/dd/yyyy):	
Your Contact Details (required)	
Name:	
Address:	
Phone:	
Email:	

For purchases made in **CANADA:**

FPI Fireplace Products International Ltd.
6988 Venture St.
Delta, British Columbia
Canada, V4G 1H4

Phone: 604-946-5155
Fax: 1-866-393-2806

For purchases made in the **UNITED STATES:**

Fireplace Products US, Inc.
PO Box 2189 PMB 125
Blaine, WA
United States, 98231

Phone: 604-946-5155
Fax: 1-866-393-2806

For purchases made in **AUSTRALIA:**

Fireplace Products Australia Pty Ltd
99 Colemans Road
Dandenong South, Vic.
Australia, 3175

Phone: +61 3 9799 7277
Fax: +61 3 9799 7822

For fireplace care and tips and answers to most common questions please visit our Customer Care section on our Web Site. Please feel free to contact your selling dealer if you have any questions about your Regency product.

recycling

PRODUCT LIFE CYCLE:

By recycling your used appliances, you divert waste from your local landfills and help the environment. You also reduce the need for raw materials to manufacture new products. Contact your local municipality for appliance recycling services, local recycling programs, or appliance removal services to ensure your Regency appliance components, and packaging are properly recycled.

Installer: Please complete the following information

Dealer Name & Address: _____

Installer: _____

Phone #: _____

Date Installed: _____

Serial #: _____



Horizon HZO42 Product Video