



Alterra F175B-2 Freestanding Wood Fire



Model: F175B-2

**PLEASE KEEP THESE INSTRUCTIONS FOR
FUTURE REFERENCE**

WARNING:

Improper installation, adjustment, alteration, service or maintenance can cause injury or property damage. Refer to this manual. For assistance or additional information consult an authorised installer, service agency or the distributor.

FOR YOUR SAFETY

Do not store or use petrol or other flammable vapours and liquids in the vicinity of this or any other appliance.

Installation and service must be performed by an authorised installer, service agency or the gas supplier.

Thank-you for purchasing a
REGENCY FIREPLACE PRODUCT.

The pride of workmanship that goes into each of our products will give you years of trouble-free enjoyment. Should you have any questions about your product that are not covered in this manual, please contact the **REGENCY DEALER** in your area.

Keep those **REGENCY FIRES** burning.

SAFETY NOTE: If this wood fire is not properly installed, a house fire may result. For your safety, follow the installation instructions, contact local building, fire officials, or authority having jurisdiction about restrictions and installation inspection requirements in your area.

The authority having jurisdiction should be consulted before installation to determine the need to obtain a permit.

DO NOT BURN (WILL VOID WARRANTY):

- Treated wood
- Cardboard
- Tea Tree
- Solvents
- Oil Based woods
- Colored Paper
- Coal
- Trash
- Garbage

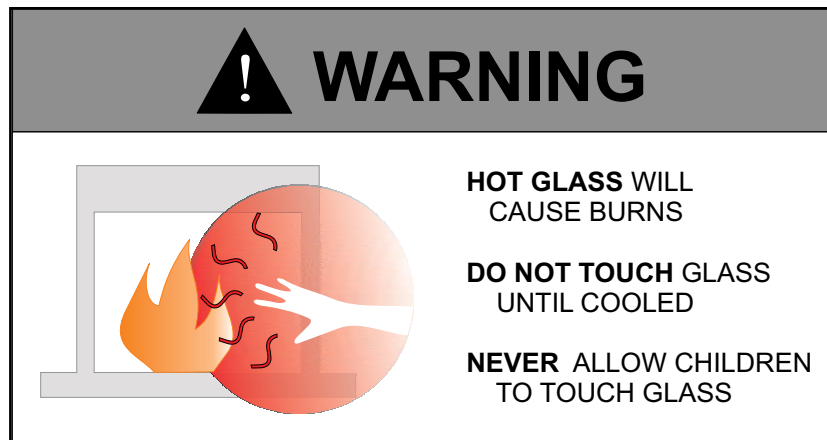

TABLE OF CONTENTS

Data Badge.....	4
Unit Dimensions	5

INSTALLATION

Residential Installation.....	6
Safety Guidelines and Warnings	6
Brick Installation	6
Side Panel Installation	7
Fan Installation	7
Fan Wiring Diagram.....	7
Clearance to Combustibles	8
Floor Protection	8

OPERATING INSTRUCTIONS

Operating Instructions	9
Air Slide Control.....	9
First Fire	9

MAINTENANCE

Maintenance	10
Creosote	10
- Ways to Prevent & Keep Units Free of Creosote	10
Glass Maintenance.....	10
Door Latch Adjustment	10
Wood Storage.....	10

PARTS LIST

Stove Assembly	11
----------------------	----

WARRANTY

Warranty	14
----------------	----

COMPLIANCE PLATE

This is a copy of the label that accompanies each F175B-2 Freestanding Wood Fire. We have printed a copy of the contents here for your review.

NOTE: Regency units are constantly being improved. Check the label on the unit and if there is a difference, the label on the unit is the correct one.

MAKE: REGENCY	
TYPE: FREESTANDING WOODFIRE	
Model: ALTERRA F175B-2	Serial Number 396
TESTED BY: HRL TECHNOLOGY PTY LTD. TRAMWAY ROAD MORWELL VICTORIA 3840 (May 2015)	
TEST REPORT NUMBER: HCMG/15/030	
WHEN TESTED IN ACCORDANCE WITH AS/NZS 4012:2014 & AS/NZS 4013:2014	
MAXIMUM AVERAGE HEAT OUTPUT BURNING HARDWOOD: 11kW	
OVERALL AVERAGE EFFICIENCY BURNING HARDWOOD: 70%	
PARTICULATE EMISSION FACTOR: 0.5g/kg	
CATALYTIC COMBUSTOR: NO	
MANUFACTURER/DISTRIBUTOR: FIREPLACE PRODUCTS AUSTRALIA PTY. LTD. 1 CONQUEST WAY, HALLAM VIC 3803	
Date of Manufacture:	
JAN FEB MAR APR MAY JUN JUL AUG SEP OCT NOV DEC	2015 2016 2017
<input type="checkbox"/> <input type="checkbox"/> <input type="checkbox"/> <input type="checkbox"/> <input type="checkbox"/> <input type="checkbox"/> <input type="checkbox"/> <input type="checkbox"/> <input type="checkbox"/> <input type="checkbox"/> <input type="checkbox"/> <input type="checkbox"/>	<input type="checkbox"/> <input type="checkbox"/> <input type="checkbox"/>

919-095b

UNIT DIMENSIONS

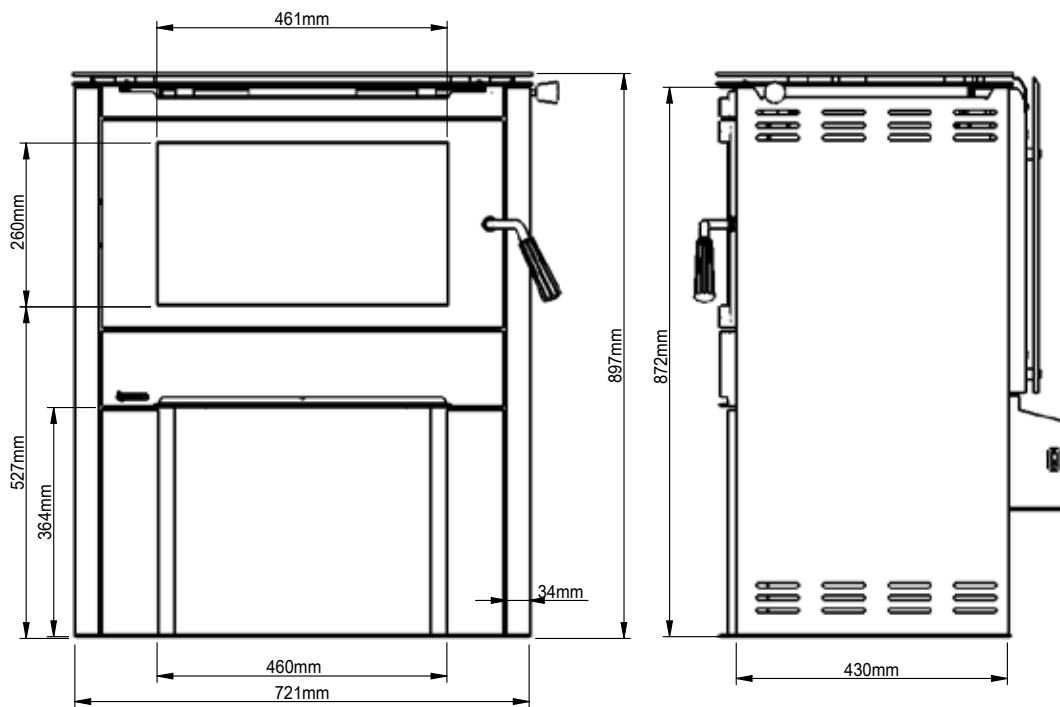
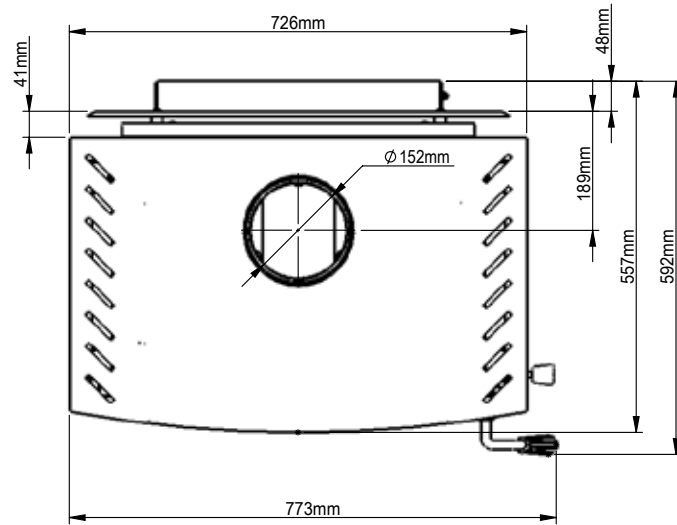

INSTALLATION

RESIDENTIAL INSTALLATION

- 1) Please read this entire manual before you install and use your new wood fire. Failure to follow instructions may result in property damage, bodily injury or even death. Be aware that local Codes and Regulations may override some items in this manual. Check with your local inspector.
- 2) **THE APPLIANCE AND FLUE-SYSTEM SHALL BE INSTALLED IN ACCORDANCE WITH AS/NZS 2918:2001 AND THE APPROPRIATE REQUIREMENTS OF THE RELEVANT BUILDING CODE OR CODES.**

APPLIANCES INSTALLED IN ACCORDANCE WITH THIS STANDARD SHALL COMPLY WITH THE REQUIREMENTS OF AS/NZS 4013 WHERE REQUIRED BY THE REGULATORY AUTHORITY.

ANY MODIFICATION OF THE APPLIANCE THAT HAS NOT BEEN APPROVED IN WRITING BY THE TESTING AUTHORITY IS CONSIDERED TO BE IN BREACH OF THE APPROVAL GRANTED FOR COMPLIANCE WITH AS/NZS 4013.

CAUTION: MIXING OF APPLIANCE OR FLUE-SYSTEM COMPONENTS FROM DIFFERENT SOURCES OR MODIFYING THE DIMENSIONAL SPECIFICATION OF COMPONENTS MAY RESULT IN HAZARDOUS CONDITIONS. WHERE SUCH ACTION IS CONSIDERED, THE MANUFACTURER SHOULD BE CONSULTED IN THE FIRST INSTANCE.

- 3) Select a position for your Regency Stove. Consult the minimum clearance chart for your model and set the stove in place. For close clearance installation use listed double wall connector systems.
- 4) To insure vertical alignment, suspend a plumb bob from the ceiling over the exact center of your stove flue and mark a spot on the ceiling to indicate the center of the chimney.
- 5) Check that the area above the ceiling is clear for cutting. Re-confirm the clearance from the stove to combustibles to insure that they are within the prescribed limits.
- 6) Mark the location of the pedestal base on the floor, then move the stove aside and mark the position of the floor protector.
- 7) Install chimney according to chimney manufacturers instructions. The performance of your wood fire is governed to a very large part by the chimney system. Too short a chimney can cause difficult start-up, dirty glass, backsmoking when door is open, and

even reduced heat output. Too tall a chimney may prompt excessive draft which can result in very short burn times and excessive heat output.

- 8) The floor protector must be of non-combustible material. Refer to page 7 for floor protector clearances.
- 9) When the floor protection is complete, position the stove with the flue collar centered under the installed chimney.
- 10) In seismically active areas, Regency recommends that your unit is secured to the floor by using the bolt down holes inside the pedestal.
- 11) **Do not connect this unit to a chimney serving another appliance.**

SAFETY GUIDELINES AND WARNINGS

- 1) Never use petrol, petrol type lantern fuels, kerosene, charcoal lighter fuel, or similar liquids to start or 'freshen up' a fire in your heater. Keep all such liquids well away from the heater while it is in use.
- 2) Keep the door closed during operation and maintain all seals in good condition.
- 3) Do not burn any quantities of paper, garbage, and never burn flammable fluids such as petrol, naphtha or engine oil in your stove.
- 4) If you have smoke detectors, prevent smoke spillage as this may set off a false alarm.
- 5) Do not overfire heater. If the chimney connector, flue baffle or the stove top begin to glow, you are overfiring. Stop adding fuel and close the draft control. Overfiring can cause extensive damage to your stove including warpage and premature steel corrosion. Overfiring will void your warranty.
- 6) Do not permit creosote or soot build-up in the chimney system. Check and clean chimney at regular intervals. Failure to do so can result in a serious chimney fire.
- 7) Your Regency stove can be very hot. You may be seriously burned if you touch the stove while it is operating, keep children, clothing and furniture away. Warn children of the burn hazard. For safety reasons a guard around the fire is recommended.
- 8) The stove consumes air while operating, provide adequate ventilation with an air duct or open a window while the stove is in use.
- 9) Do not connect this unit to a chimney flue serving another appliance.

10) Do not use grates or andirons or other methods for supporting fuel. Burn directly on the base or bricks where supplied.

11) Open the draft control fully for 10 to 15 seconds prior to slowly opening the door when refuelling the fire.

12) Do not connect your unit to any air distribution duct.

13) Your wood fire should burn dry, standard firewood only. The use of cut timber, plywood, "mill ends", etc. is not allowed as this fuel can easily overheat your wood fire. Evidence of excessive overheating will void your warranty. As well, a large portion of sawmill waste is chemically treated timber, which is illegal to burn in many areas. Salt drift wood and chemically treated fire logs also must not be burned in your wood fire.

14) No combustible material should be closer than the clearances, see page 7.

15) **DO NOT OPERATE WITH BROKEN GLASS.**

BRICK INSTALLATION

Firebrick comes installed in each stove and is made to extend the life of your stove and to radiate heat more evenly.

Important: Remove the packing material from above and below the top bricks. Check to see that all firebricks are in their correct positions and have not become misaligned during shipping.

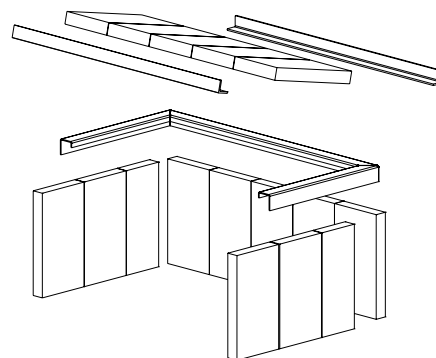

SIDE PANEL INSTALLATION

Install side panels with screws as shown in diagram.

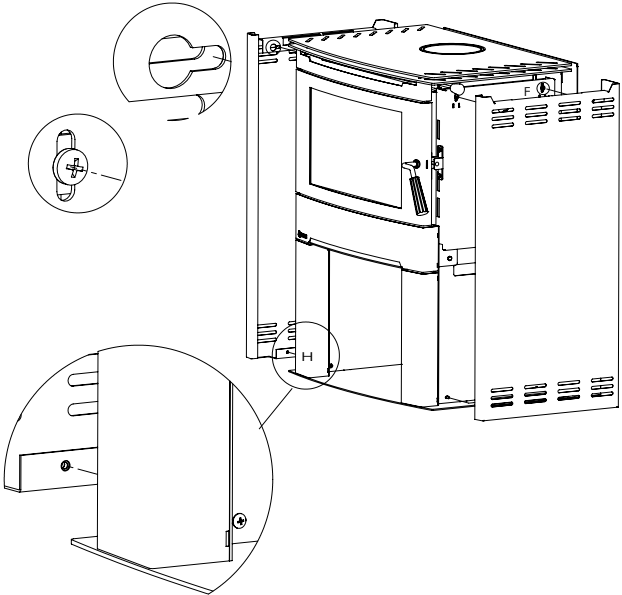

Diagram 1 - Side Panel Install

FAN INSTALLATION

A 2 speed fan is supplied and needs to be fitted to the rear of the unit with screws supplied.

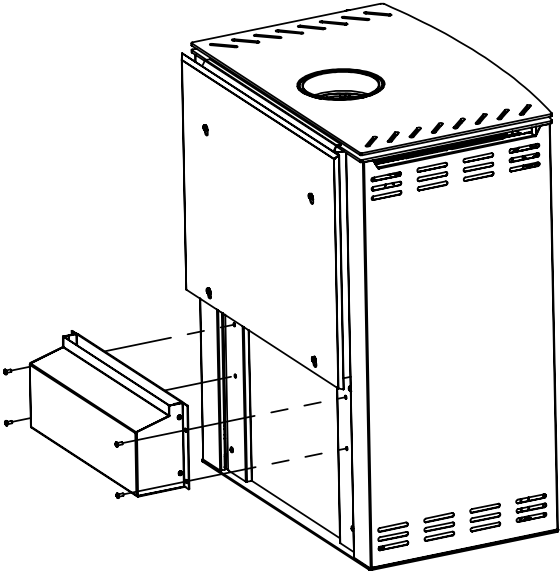

Diagram 1 - Fan Install

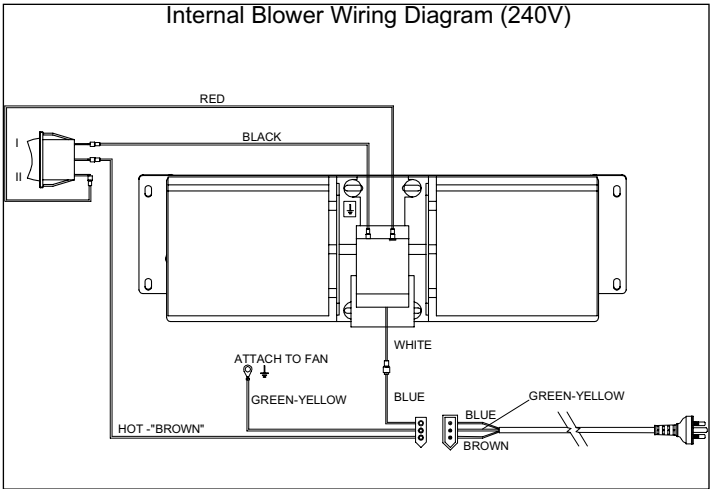
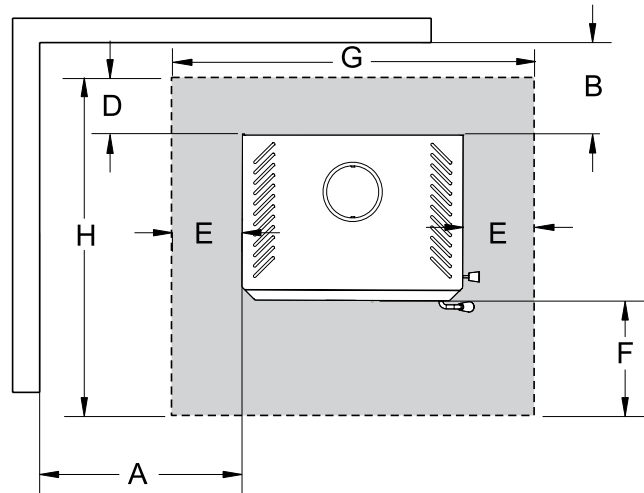

Diagram 2 - Fan Wiring Diagram

INSTALLATION

MINIMUM CLEARANCE TO COMBUSTIBLE MATERIALS

	Universal Default (1)	AHD Special (2)
A	475mm	475mm
*B	160mm	160mm
C	175mm	175mm
D	160mm	160mm
E	78mm	78mm
F	300mm	300mm
G	875mm	875mm
H	969mm	969mm



* Wall clearance taken from rear shield (not fan).

Floor Protection

A combustible floor must be protected by non-combustible material (like tile, concrete board, or as defined by local codes) extending beneath the heater as follows;

From Sides: 78mm (E)
 From Front: 300mm(F)
 From Back Shield: 160mm(D)

The floor protector should consist of 12mm thick cement fibre sheet which has a thermal resistance of 0.8m² k/w for 4mm sheets of cement fibre sheet.

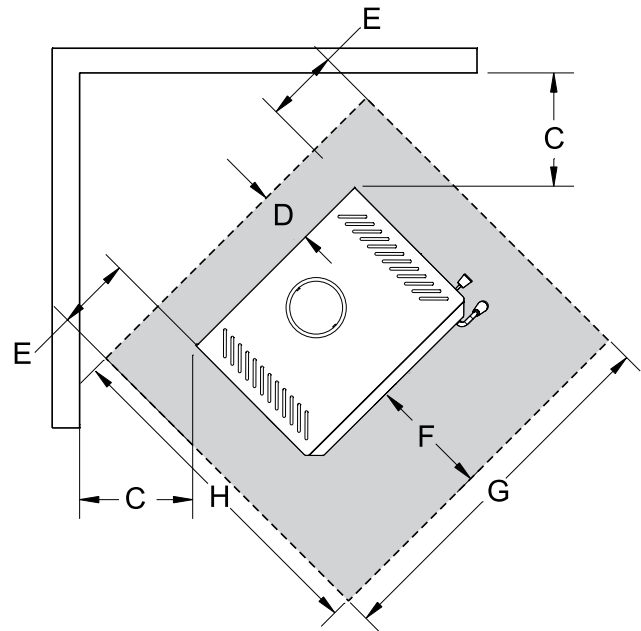

IMPORTANT

* (1) The **Universal Default flue kit** requires one 130° x 900mm stainless reflective shield; fitted to the rear of the active flue.

* (2) The **AHD Special Insulated flue kit** must be installed with a 40mm air gap around the flue to any combustible surfaces and the ceiling ring must be spaced as such to provide an air gap of 20mm to the ceiling.

A 130° x 900mm stainless reflective must be fitted behind the active flue.

The flue pipe shall extend not less than 4.6m above the top of the floor protector.

NOTE: Installation must be carried out by a licensed installer in accordance with AS/NZS 2918:2001.

NOTE: A minimum clearance of 160mm (flat wall) or 175mm (corner wall) must be retained for all wall surfaces to allow for fan access and maintenance.

OPERATING INSTRUCTIONS

OPERATING INSTRUCTIONS

With your unit now correctly installed and safety inspected by your local authority, you are now ready to start a fire. Before establishing your first fire, it is important that you fully understand the operation of your draft control.

CAUTION: THIS APPLIANCE MUST BE MAINTAINED AND OPERATED AT ALL TIMES IN ACCORDANCE WITH THESE INSTRUCTIONS.

CAUTION: THE USE OF SOME TYPES OF PRESERVATIVE-TREATED WOOD AS FUEL CAN BE HAZARDOUS.

WARNING: ANY MODIFICATION OF THE APPLIANCE THAT HAS NOT BEEN APPROVED IN WRITING BY THE TESTING AUTHORITY IS CONSIDERED AS BREACHING AS/NZS 4013.

WARNING: DO NOT USE FLAMMABLE LIQUIDS OR AEROSOLS TO START OR REKINDLE THE FIRE.

WARNING: DO NOT USE FLAMMABLE LIQUIDS OR AEROSOLS IN THE VICINITY OF THIS APPLIANCE WHEN IT IS OPERATING.

WARNING: DO NOT STORE FUEL WITHIN HEATER INSTALLATION CLEARANCES.

WARNING: OPEN AIR CONTROL (AND DAMPER WHEN FITTED) BEFORE OPENING FIRING DOOR.

For safety reasons and in order to avoid over firing of your unit do not burn your fire with the door open or ajar.

AIR SLIDE CONTROL

Both the primary and air wash drafts are controlled by the control rod located on the right side of the unit (when facing the unit). To increase your draft - pull open, and to decrease - push closed. All units have a secondary draft system that continually allows combustion air to the induction ports at the top of the firebox, just below the flue baffle.

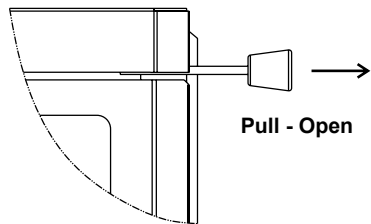
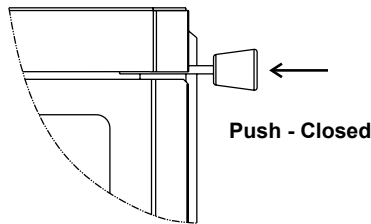

WARNING: To build a fire in ignorance or to disregard the information contained in this section can cause serious permanent damage to the unit and void your warranty!!

FIRST FIRE

When your installation is completed and inspected you are ready for your first fire.

- 1) Open control fully.
- 2) Open firebox door and build a small fire using paper and dry kindling on the firebox base. Secure door on the firebox and wait a few minutes for a good updraft in the flue to establish the fire. (Leaving the door slightly open will help your fire start more rapidly.)

CAUTION: Never leave unit unattended if door is left open. This procedure is for fire start-up only, as unit may overheat if door is left open for too long.

- 3) With the draft still in the fully open position add two or three seasoned logs to your fire. Form a trench in the ash bed to allow air to reach the rear of the firebox prior to closing the door.
- 4) After about 45 minutes, when your wood has begun to burn strongly, adjust your draft control down to keep the fire at a moderate level.

WARNING: Never build a roaring fire in a cold stove. Always warm your stove up slowly!

- 5) Once a bed of coals has been established on the base of the firebox, you may adjust the draft control to a low setting to operate the unit at its most efficient mode.
- 6) During the first few fires, keep the combustion rate at a moderate level and avoid a large fire. Only after 5 or 6 such fires can you operate the stove at its maximum setting, and only after the metal has been warmed.
- 7) For the first few days, the stove will give off an odour from the paint. This is to be expected as the high temperature paint becomes seasoned. Windows and/or doors should be left open to provide adequate ventilation while this temporary condition exists. Burning the stove at a very high temperature the first few times may damage the paint. Burn fires at a moderate level the first few days.
- 8) Do not place anything on the stove top during the curing process. This may result in damage to your paint finish.

MAINTENANCE

- 9) During the first few days it may be more difficult to start the fire. As you dry out your firebrick and your masonry flue, your draft will increase.
- 10) For those units installed at higher elevations or into sub-standard masonry fireplaces, drafting problems may occur. Consult an experienced dealer or mason on methods of increasing your draft.
- 11) Some cracking and popping noises may be experienced during the heating up process. These noises will be minimal when your unit reaches temperature.
- 12) Before opening your door to reload, open draft fully for approximately 10 to 15 seconds until fire has been re-established. This will minimize any smoking.
- 13) All fuel burning appliances consume oxygen during operation. It is important that you supply a source of fresh air to your unit while burning. A slightly opened window is sufficient for the purpose. If you also have a fireplace in your home, a downdraft may be created by your Regency Stove causing a draft down your chimney. If this occurs, slightly open a window near your unit.

CAUTION: If the body of your unit, flue baffle or any part of the chimney connector starts to glow, you are overfiring. Stop loading fuel immediately and close the draft control until the glow has completely subsided.

- 14) Green or wet wood is not recommended for your unit. If you must add wet or green fuel, open the draft control fully until all moisture has been dispersed by the intense fire. Once all moisture has been removed, the draft control may be adjusted to maintain the fire.
- 15) If you have been burning your stove on a low draft, use caution when opening the door. After opening the damper, open the door a crack, and allow the fire to adjust before fully opening the door.
- 16) The controls of your unit or the air supply passages should not be altered to increase firing for any reason.
- 17) If you burn the unit too slowly or at too low a setting your unit will not be operating as efficiently as it can. An easy rule of thumb says that if your glass is clean, then your flue is clean and your exhaust is clean. Burn the stove hot enough to keep your glass clean and you won't need to clean your flue as often.

CREOSOTE

When wood is burned slowly, it produces tar and other organic vapours, which when combined with moisture, form creosote. The creosote vapours condense in the relatively cool chimney flue of a slow burning fire. As a result, creosote residue accumulates on the flue lining. When ignited, this creosote can result in an extremely hot fire.

WARNING: Things to remember in case of a chimney fire:

1. Close all draft and damper controls.
2. CALL THE FIRE DEPARTMENT.

Ways to Prevent and Keep Unit Free of Creosote

- 1) Burn stove with the draft control wide open for about 10-15 minutes every morning during burning season.
- 2) Burn stove with draft control wide open for about 10 - 15 minutes every time you apply fresh wood. This allows the wood to achieve the charcoal stage faster and burns up any unburned gas vapours which might otherwise be deposited within the system.
- 3) **Only burn seasoned wood!** Avoid burning wet or green wood. Seasoned wood has been dried at least one year.
- 4) A small hot fire is preferable to a large smouldering one that can deposit creosote within the system.
- 5) The chimney and chimney connector should be inspected at least once every two months during the heating season to determine if a creosote buildup has occurred
- 6) **Have chimney system and unit cleaned by competent chimney sweeps twice a year during the first year of use and at least once a year thereafter or when a significant layer of creosote has accumulated (3 mm/1/8" or more) it should be removed to reduce the risk of a chimney fire.**

WOOD STORAGE

Store wood under cover, such as in a shed, or covered with a tarp, plastic, tar paper, sheets of scrap plywood, etc., as uncovered wood can absorb water from rain or snow, delaying the seasoning process.

MAINTENANCE

It is very important to carefully maintain your fireplace stove, including burning seasoned wood and maintaining a clean stove and chimney system. Have the chimney cleaned before the burning season and as necessary during the season, as creosote deposits may build up rapidly. Moving parts of your stove require no lubrication. The integrity of all heater parts including baffle plates, cast iron liners, fire bricks, air tubes, air bars, door rope seals, and door glass is imperative for the correct operation and longevity of your Regency Wood heater. They should be inspected on a regular basis and replaced if they show any signs of undue wear or damage. Failure of any of these components can damage the heater and void warranty.

GLASS MAINTENANCE

Your Regency stove is supplied with 5 mm Neoceram ceramic glass that will withstand the highest heat that your unit will produce. In the event that you break your glass by impact, purchase your replacement from an authorized Regency dealer only, and follow our step-by-step instructions for replacement.

Allow the stove to cool down before cleaning the glass, do not clean the glass when it is hot. Do not use abrasive cleaners.

DOOR LATCH ADJUSTMENT

The door latch may require adjustment as the door gasket material compresses over time.

Follow the steps below to allow the latch to be moved closer to the door frame, causing a tighter seal;

- 1) Remove split pin and roller sleeve.
- 2) Spin door handle anti-clockwise to tighten.
- 3) Replace split pin and roller sleeve.

* Set screw with Allen key provided.

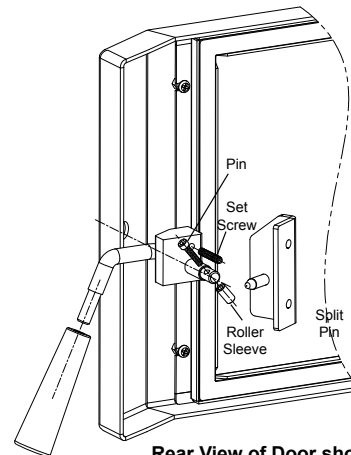

Rear View of Door shown

STOVE ASSEMBLY

Part #	Description	Part #	Description		
1)	1391000	Firebox Assembly	13) 1390003	Bottom Rear Plate	
2)	1391600	Airslide	14)	1396000	Fan Kit Assembly
2a)	1141800	SS Air Tube Assembly	15)	1390004	Black Right Panel
3)	1390001	Door Hinge	1390007	SS Right Panel	
4)	8010108B	Brick Set	16)	1395000	Top Panel
5)	1394000	Legs Assembly	17)	1390005	Black Left Panel
6)	8010114	Door Handle Set	1390008	SS Left Panel	
7)	1392100	Door Frame	18)	1390009	Rear Shield
8)	3720202	Gasket	19)	4030214	M6X30 Hex Bolt
9)	1392001	Glass w/o Gasket	20)	1390011	Fan Air Deflector
10)	1392002	Glass Seal Frame	21)	1390006	Inner Heat Shield
11)	3720103	Door Seal Gasket	22)	4030207	M6X50 Hex Bolt
12)	1393000	Pedestal Assembly	23)	1390010	Clearance Sleeve 12x6.5x20L
			24)	1390002	Clearance Sleeve 12x6.5x40L

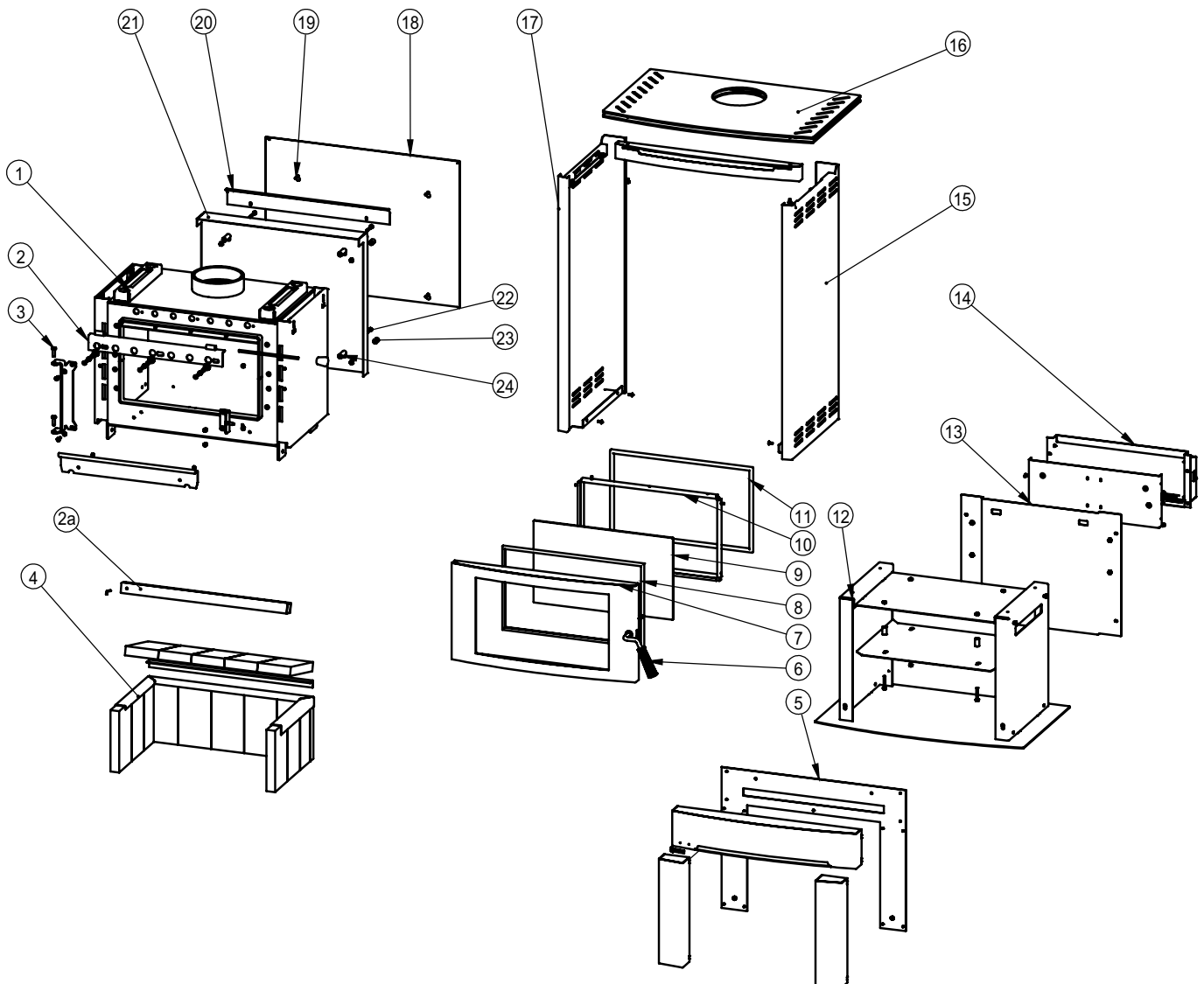

WARRANTY



Regency® Fireplace Products are designed with reliability and simplicity in mind. In addition, our internal Quality Assurance Team carefully inspects each unit thoroughly before it leaves our door. Regency® is pleased to extend this limited lifetime warranty to the original purchaser of a Regency® Product. Regency® will repair or replace goods free of charge in the event of defects arising from faulty materials or workmanship in accordance with the warranty terms in relation to Definitions, Warranty Conditions and Exclusions stated in this document.

The benefits to the consumer given by this warranty are in addition to all other rights and remedies of the consumer under a law in relation to the goods or services to which the warranty relates.

Our goods come with the guarantees that cannot be excluded under the Australian Consumer Law. You are entitled to a replacement or refund for a major failure and for compensation for any other foreseeable loss or damage. You are also entitled to have the goods repaired or replaced if the goods fail to be of acceptable quality and the failure does not amount to a major failure.

The Warranty:

Covered under the agreement **against manufacturer's defects from the date of purchase** are the following components:

The Firebox for 15 years; **(Parts & labour for the first 5 Years and parts only thereafter)**
Steel Baffles, Air Tubes, Stainless Steel Air Bars for 12 months;
Cast Iron Liners / Baffles for 2 years;
Electrical components (ie. fans, switches) for 12 months. **(Parts & labour from the invoiced purchase date)**

Regency Fireplace Products is not liable for freight or labour on any wood burning appliance replaced in field.

Repair/replacement parts purchased by the consumer from Regency Fireplace Products after the original coverage has expired on the unit will carry a 90 day warranty, valid with a receipt only. Any item shown to be defective will be repaired or replaced at our discretion. No labour coverage is included with these parts.

Conditions:

Any part or parts of this unit which in our judgement show evidence of such defects will be repaired or replaced at Regency Fireplace Product's option, through an accredited distributor or agent provided that the defective part be returned to the distributor or agent **Transportation Prepaid**, if requested. In areas where there is not an approved service agent or the closest approved service agent is situated more than thirty (30) kilometres from the installation, Regency is not obliged to arrange warranty repairs and travel and/or additional labour charges will apply.

It is the general practice of Regency Fireplace Products to charge for larger, higher priced replacement parts and issue credit once the replaced component has been returned to Regency Fireplace Products and evaluated for manufacturer defect.

The authorised selling dealer is responsible for all in-field service work carried out on your Regency product. Regency Fireplace Products will not be liable for results or costs of workmanship from unauthorised service persons or dealers.

At all times Regency Fireplace Products reserves the right to inspect product in the field which is claimed to be defective.

All claims must be submitted to Regency Fireplace Products by authorized selling dealers. It is essential that all submitted claims provide all of the necessary information including customer name, purchase date, serial #, type of unit, problem, and part or parts requested, without this information the warranty will be invalid.

Exclusions:

This warranty does not extend to or include paint, door or glass gasketing, neo-ceramic glass, firebrick or trim. It does not cover installation and operational related problems such as over-firing, use of corrosive driftwood, downdrafts or spillage caused by environmental conditions, nearby trees, buildings, hilltops, mountains, inadequate flueing or ventilation, excessive offsets, negative air pressures caused by mechanical systems such as furnaces, fans, clothes dryers etc.

At no time will Regency Fireplace Products be liable for any consequential damages which exceed the purchase price of the unit. Regency Fireplace Products has no obligation to enhance or modify any unit once manufactured. ie. as products evolve, field modifications or upgrades will not be performed.

Regency Fireplace Products will not be liable for travel costs for service work.

Installation and environmental problems are not the responsibility of the manufacturer and therefore are not covered under the terms of this warranty policy.

Any unit which shows signs of neglect or misuse is not covered under the terms of this warranty policy.

The warranty will not extend to any part which has been tampered with or altered in any way, or in our judgment has been subject to misuse.

Freight damage to stoves and replacement parts is not covered by warranty and is subject to a claim against the freight carrier by the dealer.

Regency Fireplace Products will not be liable for acts of God, or acts of terrorism, which cause malfunction of the appliance.

Performance problems due to operator error will not be covered by this warranty policy.

Products made or provided by other manufacturers and used in conjunction with the operation of this appliance without prior authorisation from Regency Fireplace Products may nullify your warranty on this product.

SUBJECT TO CHANGE.

WARRANTY

DISTRIBUTORS:	Western Australia	Eastern Australia	New Zealand
	Air Group Australia	Fireplace Products Australia PTY. Ltd.	Aber Holdings
	28-30 Division St.	1-3 Conquest Way	17 Mainstreet Place
	Welshpool, WA 6106	Hallam, VIC 3803	Te Rapa Ha. 3200
	08 9350 2200	03 9799 7277	07 849 7585

NOTE: PLEASE RETAIN YOUR INVOICE AS PROOF OF PURCHASE FOR WARRANTY VERIFICATION

INCORRECT INSTALLATION OR GAS PRESSURE SETTINGS ARE NOT COVERED BY WARRANTY

A SERVICE OR CALLOUT FEE WILL BE CHARGED IN THESE CIRCUMSTANCES.

Register your Regency® warranty online

www.regency-fire.com.au



Reasons to register your product online today!

- View and modify a list of all your registered products.
- Request automatic email notification of new product updates.
- Stay informed about the current promotions, events, and special offers on related products.
- Help assure you get the most out of your warranty.
- Eliminate confusion and frustration if warranty** service is required in the future.

** Proof of purchase required at time of warranty request.

Installer: Please complete the following information

Dealer Name & Address: _____

Installer: _____

Phone #: _____

Date Installed: _____

Serial No.: _____