

Owners &
Installation



MONTROSE WOOD FIREPLACE

Model: L850B

Manual



**PLEASE KEEP THESE INSTRUCTIONS FOR
FUTURE REFERENCE**

WARNING:

Improper installation, adjustment, alteration, service or maintenance can cause injury or property damage. Refer to this manual. For assistance or additional information consult an authorised installer, service agency or the distributor.

It is highly recommended for protection of infants and infirm to place a secure safety guard in front of this appliance when in operation.

Thank-you for purchasing a
REGENCY FIREPLACE PRODUCT

The pride of workmanship that goes into each of our products will give you years of trouble-free enjoyment. Should you have any questions about your product that are not covered in this manual, please contact the **REGENCY DEALER** in your area.

Keep those **REGENCY FIRES** burning.

SAFETY NOTE: If this wood fire is not properly installed, a house fire may result. For your safety, follow the installation instructions, contact local building, fire officials, or authority having jurisdiction about restrictions and installation inspection requirements in your area.

The authority having jurisdiction should be consulted before installation to determine the need to obtain a permit.

CAUTION: BURN UNTREATED WOOD ONLY. OTHER MATERIALS SUCH AS WOOD PRESERVATIVES, METAL FOILS, COAL, PLASTIC, GARBAGE, SULPHUR OR OIL WILL DAMAGE THE FIRE AND ATMOSPHERE.

"This wood heater is designed to burn natural wood only. Higher efficiencies and lower emissions generally result when burning air dried seasoned hardwoods, as compared to green or freshly cut hardwoods."

DO NOT BURN (WILL VOID WARRANTY):

- Treated wood
- Cardboard
- Tea Tree
- Solvents
- Oil Based woods
- Colored Paper
- Coal
- Trash
- Garbage

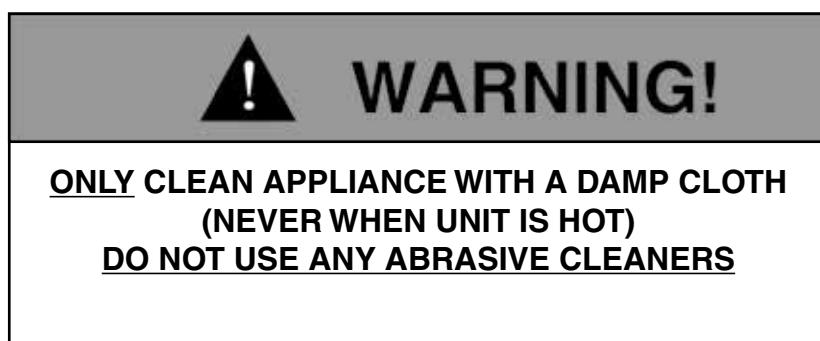

Compliance Plate4
Unit Dimensions5

INSTALLATION

Before Installing Your Fireplace6
Safety Guidelines and Warnings7
Wood Fireplace Specifications8
Wood Fireplace Specifics-Minimum Clearances9
Optional Base Frame10
Flue and Flue Requirements11
Installation Instructions15
Optional Fan Kit Installation
 Listing and Code Approvals18
 General Information18
 Minimum Framing Clearances18
 Fan Kit Installation19
 Fan Duct Extension Kit20
 Wiring Diagram20
Optional Outside Air Kit Installation21
Brick Installation22

APPLIANCE MAINTENANCE

Creosote23
Ash Removal23
Glass Installation23
Glass Maintenance23
Door Latch Adjustment23
Trouble Shooting24

OPERATING INSTRUCTIONS

Additional Warnings25
Air Slide Control25
Fuel Requirements25
Lighting the Appliance26

PARTS LIST

Main Assembly27

WARRANTY

Installation of Appliance Checklist29
Warranty30

compliance plate

This is a copy of the data badge that accompanies each L850B Fireplace. We have included a copy of the contents here for your review.

NOTE: Regency units are constantly being improved. Check the data badge on the unit and if there is a difference, the data badge on the unit is the correct one.

COPY OF DATA BADGE

MAKE: REGENCY	
TYPE: FIREPLACE INSERT	
Model: MONTROSE L850B	Serial Number 433
TESTED BY: HRL TECHNOLOGY PTY LTD. TRAMWAY ROAD MORWELL VICTORIA 3840 (2014) WHEN TESTED IN ACCORDANCE WITH AS/NZS 4012:2014 & AS/NZS 4013:2014 MAXIMUM AVERAGE HEAT OUTPUT BURNING HARDWOOD: 11kW OVERALL AVERAGE EFFICIENCY BURNING HARDWOOD: 62% PARTICULATE EMISSION FACTOR: 1.2 g/kg CATALYTIC COMBUSTOR: NO MANUFACTURER/DISTRIBUTOR: FIREPLACE PRODUCTS AUSTRALIA PTY. LTD. 1 CONQUEST WAY, HALLAM VIC 3803	
Date of Manufacture:	
JAN FEB MAR APR MAY JUN JUL AUG SEP OCT NOV DEC	2021 2022 2023 2024 2025
<input type="checkbox"/> <input type="checkbox"/> <input type="checkbox"/> <input type="checkbox"/> <input type="checkbox"/> <input type="checkbox"/> <input type="checkbox"/> <input type="checkbox"/> <input type="checkbox"/> <input type="checkbox"/> <input type="checkbox"/> <input type="checkbox"/>	<input type="checkbox"/> <input type="checkbox"/> <input type="checkbox"/> <input type="checkbox"/> <input type="checkbox"/>
919-371b	

PLEASE MAKE NOTE OF THE UNIT SERIAL NUMBER AND ENTER IN THE SPACE PROVIDED

UNIT DIMENSIONS

1. Clean Front Dimensions

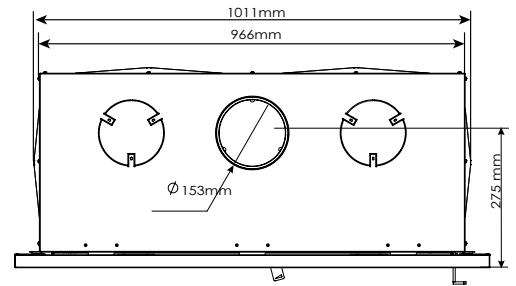
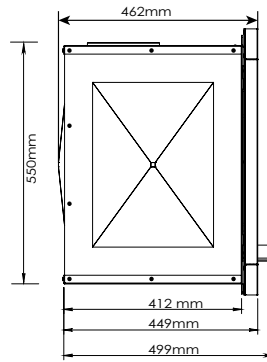
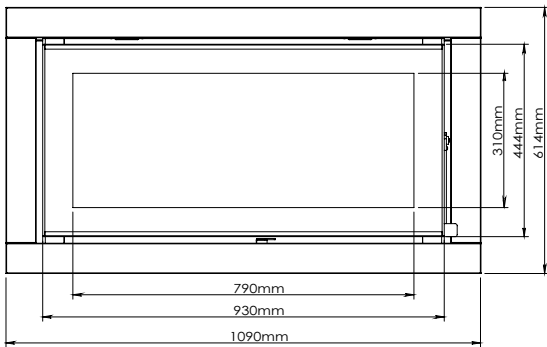

3. Reduced Clearance Box Dimensions

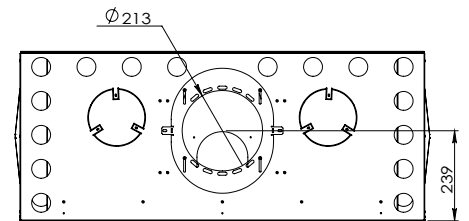
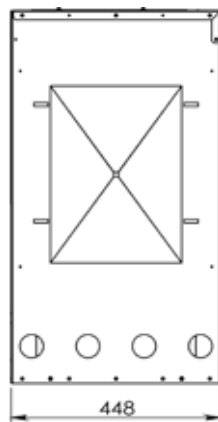
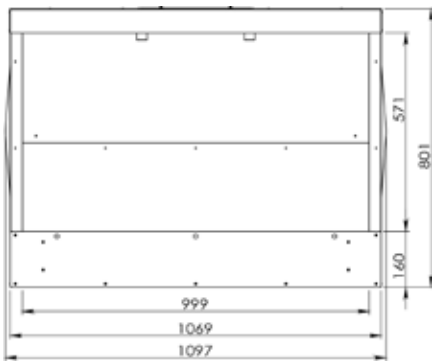

4. Standard Firebox Dimension

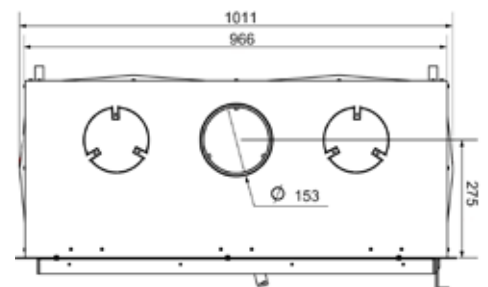
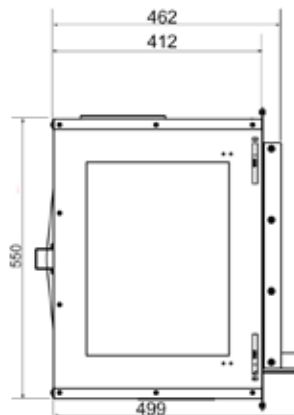
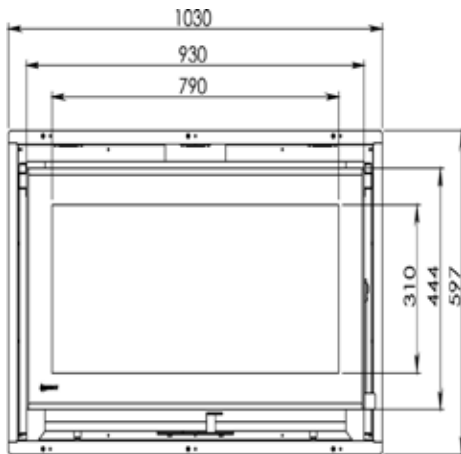

Regency Fireplaces are constructed with the highest quality materials and assembled under strict quality control procedures that ensure years of trouble free and reliable performance.

It is important that you read this manual thoroughly and fully understand the safe installation and operating procedures. The more you understand the way your Regency Fireplace operates, the more enjoyment you will experience from knowing that your unit is operating at peak performance.

BEFORE INSTALLING YOUR FIREPLACE

- 1) **Please read this entire manual before you install and use your new wood fireplace.** Failure to follow instructions may result in property damage, bodily injury or even death. Install and use only in accordance with manufacturer's installation and operating instructions.
- 2) Check your local building codes - Building Inspection Department. You may require a permit before installing your fireplace. Be aware that local codes and regulations may override some items in the manual.
- 3) Notify your home insurance company that you plan to install a fireplace insert or freestanding heater.
- 4) **THE FIREPLACE CAN GET VERY HOT. DO NOT INSTALL, PLACE OR POSITION TV'S, PAINTINGS, PICTURES, CANDLES, FURNITURE, DRAPES OR ANY OTHER COMBUSTIBLE ITEMS ON THE WALL OR NEAR THE FIREPLACE.**
- 5) ENSURE THERE ARE NO EXHAUST FANS WITHIN THE VICINITY OF THE FIREPLACE AS THIS CAN CAUSE THE FIREPLACE TO EMIT FUMES BACK INTO THE ROOM.
- 6) ENSURE THERE IS ADEQUATE AIR SUPPLY WITHIN THE ROOM/AREA THE FIREPLACE IS BEING INSTALLED IN TO ENSURE PROPER OPERATION OF THE FIREPLACE. INSTALL OPTIONAL OUTSIDE AIR KIT IF IN DOUBT.
- 7) EVALUATE THE LOCATION OF YOUR FIREPLACE AND OPTIONAL COMPONENTS. IT IS VERY IMPORTANT TO DETERMINE HOW THE FIREPLACE IS GOING TO BE FINISHED. THE FEATURES YOU WOULD LIKE TO INCORPORATE SUCH AS THE OUTSIDE AIR KIT AND EXTERNAL FAN KITS NEED TO BE EVALUATED PRIOR TO INSTALLATION.
- 8) DETERMINE WHAT THICKNESS OF YOUR DESIRED NON-COMBUSTIBLE FINISHING MATERIALS WILL BE INCLUDING THE HEAT RESISTANT NON-COMBUSTIBLE BOARD. THIS PRE-DETERMINED THICKNESS WILL DICTATE THE POSITION OF THE SUPPORT FLANGES, FRAMING AND OVERALL FINAL LOOK OF YOUR FIREPLACE.
- 9) Your fireplace is heavy and requires two or more people to move it safely. The fireplace can be badly damaged by mishandling and or injury can occur.
- 10) Do not connect the fireplace to a flue system servicing another appliance or an air distribution duct.

WARNING: CARELESS INSTALLATION IS THE MAJOR CAUSE OF SAFETY HAZARD. CHECK ALL LOCAL BUILDING AND SAFETY CODES BEFORE INSTALLATION OF UNIT.

THE APPLIANCE, WHEN INSTALLED, MUST BE ELECTRICALLY GROUNDED IN ACCORDANCE WITH LOCAL CODES.

SAFETY GUIDELINES AND WARNINGS/CAUTIONS

- 1) Never use petrol, petrol type lantern fuels, kerosene, charcoal lighter fuel, or similar liquids to start or 'freshen up' a fire in your heater. Keep all such liquids well away from the heater while it is in use.
- 2) Keep the door closed during operation and maintain all seals in good condition.
- 3) Do not burn any quantities of paper, garbage, and never burn flammable fluids such as petrol, naphtha or engine oil in your heater.
- 4) If you have smoke detectors, prevent smoke spillage as this may set off a false alarm.
- 5) Do not overfire heater. If the flue connector, flue baffle or the heater top begin to glow, you are overfiring. Stop adding fuel and close the draft control. Overfiring can cause extensive damage to your heater including warpage and premature steel corrosion. Overfiring will void your warranty.
- 6) Do not permit creosote or soot build-up in the flue system. Check and clean flue at regular intervals. Failure to do so can result in a serious flue fire.
- 7) Your Regency heater can be very hot. You may be seriously burned if you touch the heater while it is operating, keep children, clothing and furniture away. Warn children of the burn hazard. For safety reasons a guard around the fire is recommended.
- 8) The heater consumes air while operating, provide adequate ventilation with an air duct or open a window while the heater is in use or use optional outside air kit.
- 9) Do not use grates or andirons or other methods for supporting fuel. Burn directly on the base or bricks where supplied.
- 10) Open the draft control fully for 10 to 15 seconds prior to slowly opening the door when refuelling the fire.
- 11) Do not connect your unit to any air distribution duct.
- 12) Your wood fire should burn dry, standard firewood only. The use of cut timber, plywood, "mill ends", etc. is not allowed as this fuel can easily overheat your wood fire. Evidence of excessive overheating will void your warranty. As well, a large portion of sawmill waste is chemically treated timber, which is illegal to burn in many areas. Salt drift wood and chemically treated fire logs also must not be burned in your wood fire.
- 13) DO NOT OPERATE WITH BROKEN GLASS.

WARNING

Ensure that curtains, blinds and drapes cannot extend to or anywhere near the fire as this could cause an extremely dangerous operating condition. These must be secured by any means possible. Examples not limited to :
If a window or door is opened, the wind/breeze could cause them to move. Physical movement by an adolescent child.

WARNING: THE APPLIANCE AND FLUE-SYSTEM SHALL BE INSTALLED IN ACCORDANCE WITH AS/NZS 2918 AND THE APPROPRIATE REQUIREMENTS OF THE RELEVANT BUILDING CODE OR CODES.

WARNING: APPLIANCES INSTALLED IN ACCORDANCE WITH THIS STANDARD SHALL COMPLY WITH THE REQUIREMENTS OF AS/NZS 4013 WHERE REQUIRED BY THE REGULATORY AUTHORITY. I.E. THE APPLIANCE SHALL BE IDENTIFIABLE BY A COMPLIANCE PLATE WITH THE MARKING 'TESTED TO AS/NZS 4013'.

ANY MODIFICATION OF THE APPLIANCE THAT HAS NOT BEEN APPROVED IN WRITING BY THE TESTING AUTHORITY IS CONSIDERED TO BE IN BREACH OF THE APPROVAL GRANTED FOR COMPLIANCE WITH AS/NZS 4013.

CAUTION: MIXING OF APPLIANCE OR FLUE-SYSTEM COMPONENTS FROM DIFFERENT SOURCES OR MODIFYING THE DIMENSIONAL SPECIFICATION OF COMPONENTS MAY RESULT IN HAZARDOUS CONDITIONS. WHERE SUCH ACTION IS CONSIDERED, THE MANUFACTURER SHOULD BE CONSULTED IN THE FIRST INSTANCE.

CAUTION: CRACKED AND BROKEN COMPONENTS, e.g. GLASS PANELS OR CERAMIC TILES MAY RENDER THE INSTALLATION UNSAFE.

WARNING: ANY MODIFICATION OF THE APPLIANCE THAT HAS NOT BEEN APPROVED IN WRITING BY THE TESTING AUTHORITY IS CONSIDERED AS BREACHING AS/NZS 4013.

WARNING: DO NOT USE FLAMMABLE LIQUIDS OR AEROSOLS TO START OR REKINDLE THE FIRE.

WARNING DO NOT USE FLAMMABLE LIQUIDS OR AEROSOLS IN THE VICINITY OF THIS APPLIANCE WHEN IT IS OPERATING.

WARNING: DO NOT STORE FUEL WITHIN HEATER INSTALLATION CLEARANCES.

WARNING: DO NOT USE AS AN OPEN FIRE OR OPERATE WITH THE DOOR OPEN.

WARNING: OPEN AIR CONTROL (AND DAMPER WHEN FITTED) BEFORE OPENING FIRE DOOR.

CAUTION: THIS APPLIANCE SHOULD NOT BE OPERATED WITH A CRACKED GLASS.

CAUTION: THIS APPLIANCE SHOULD BE MAINTAINED AND OPERATED AT ALL TIMES IN ACCORDANCE WITH THESE INSTRUCTIONS

CAUTION: THE USE OF SOME TYPES PRESERVATIVE-TREATED WOOD AS A FUEL CAN BE HAZARDOUS

UNIT DIMENSIONS

Dimensions

The outside dimensions of the Montrose L850 including the Reduced Clearance Box is as follows:

- Width 1097mm
- Depth = 448mm
- Height = 801mm

Height of optional Base Framing Kit = 300mm

Note: Base is non-combustible and needs assembly

COMBUSTIBLE CAVITY REQUIREMENTS

Cavity Depth = Minimum 548mm - 720mm

Note: Cavity depth is determined by the position of support strips and thickness of non-combustible wall finish. Rear clearance must be a minimum of 100mm to combustibles.

CAVITY WIDTH = 1497MM TO COMBUSTIBLES.

Height of reduced clearance box off the ground should be a minimum of 300mm and supported by a non-combustible stand able to support 265kg.

Flue

- Minimum 4.5 Meters of triple skin flue required with approved cowl

Optional Ducting

- One or two optional fan forced ducting kits are available, using 150mm ducting to a max run of 9 meters

Reduced Clearance Box Dimensions

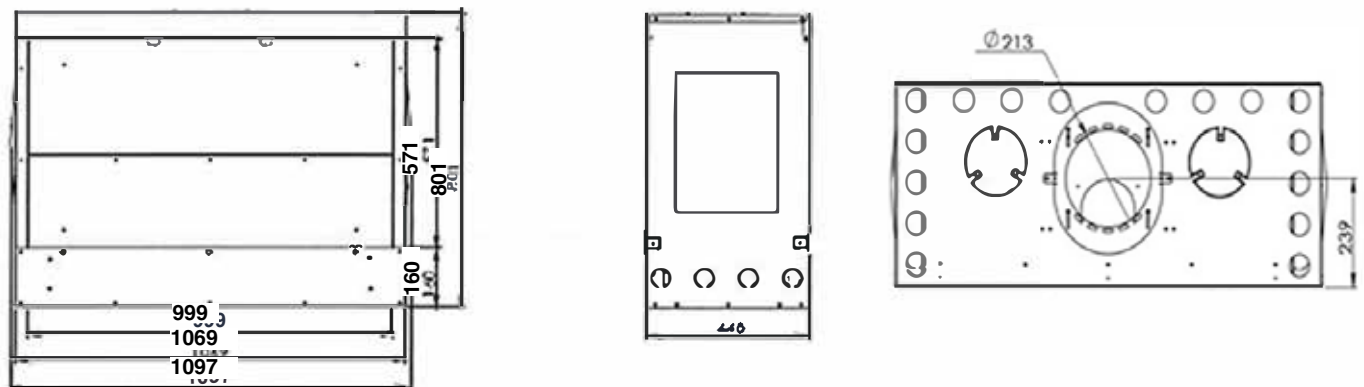

WOOD FIREPLACE SPECIFICS AND MINIMUM CLEARANCES TO COMBUSTIBLES

Framing Guide

Unit cavity to have a minimum of two 20,000mm² air vents must be installed, one 300mm from the top of the enclosure and one 50mm from the bottom of the enclosure to stop excessive heat built up in the enclosure.

Wall Materials

Non-combustible material with a minimum thickness of 9mm must be used on the front wall of the reduced enclosure. Non combustible board and non combustible cladding to finish up to the standoff brackets. Must maintain 20mm gap around entire face of unit.

Please note: Non-combustible materials need to be fit for purpose as wall temperatures can exceed 250°.

Hearth / Floor Protection Requirements

Hearth needs to be 6mm thick, 1,470mm wide and 1,100mm deep to allow for 550mm leading edge. We do recommend that your non-combustible hearth extends 900mm in front of the unit. This allows the floor to be protected when the door is fully open in case of ember drop.

The appliance must be installed on a non-combustible stand 300mm above the hearth.

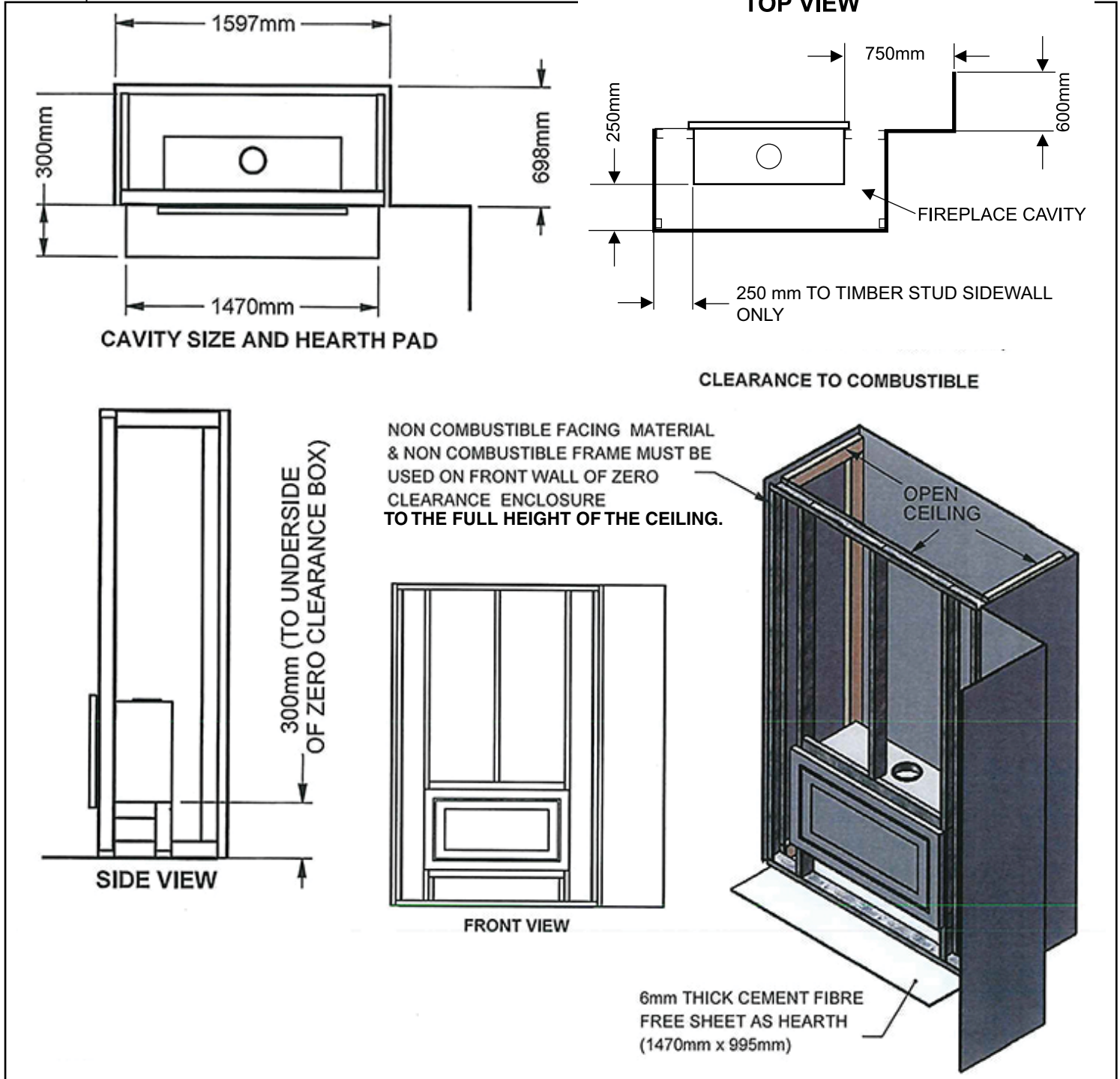

OPTIONAL BASE FRAME

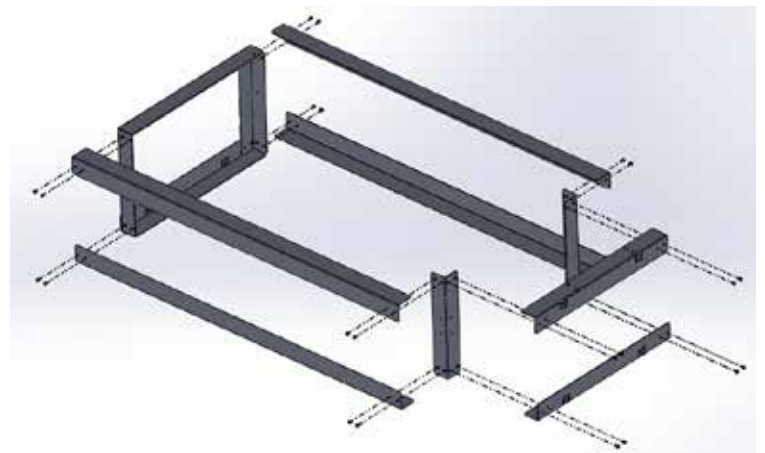
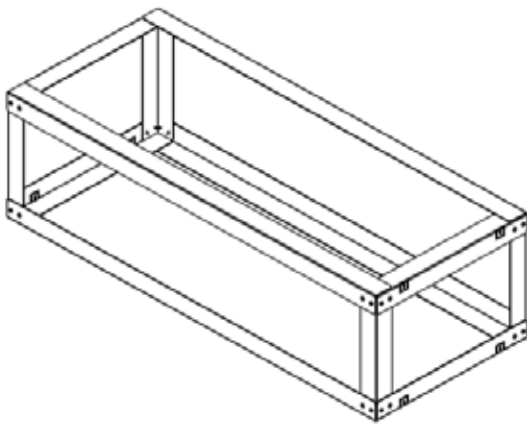
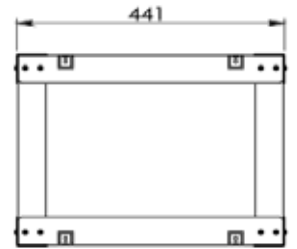
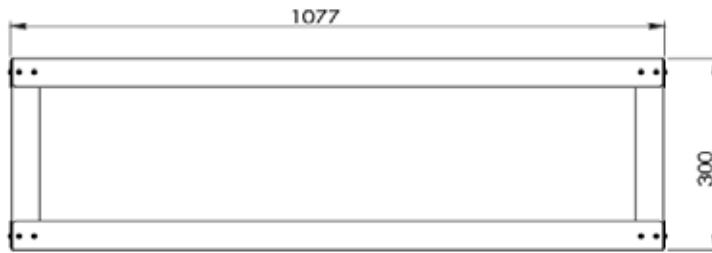

CONSTRUCTING YOUR OWN BASE FRAME

WHEN BUILDING YOUR OWN BASE FRAME OR PEDESTAL BASE PLEASE ENSURE THE FOLLOWING CONDITIONS ARE MET:

1. MINIMUM HEIGHT OF THE BASE FRAME IS 300MM FROM THE FLOOR PROTECTOR / HEARTH TO THE UNDERSIDE OF THE REDUCED CLEARANCE BOX. IF BASE FRAME DOES NOT SIT ON THE SAME LEVEL OF THE FINISHED FLOOR, THEN THE FRAME NEEDS TO BE MADE TALLER TO ENSURE THE 300MM CLEARANCE IS MET. (SEE PAGE 10).
2. ENSURE THE BASE IS HOLLOW REGARDLESS OF USING OPTIONAL OUTSIDE AIR KIT OR NOT.
3. ENSURE THE BASE IS CONSTRUCTED OF NON-COMBUSTIBLE MATERIALS
4. ENSURE THE BASE CAN WITHSTAND THE WEIGHT OF AT LEAST 265KG PLUS.
5. ENSURE THE FLOOR BENEATH THE BASE CAN WITHSTAND AT LEAST 265KG PLUS.

FLUE AND CHIMNEY REQUIREMENTS

PLEASE READ AND REFER TO INSTALLATION INSTRUCTIONS UNIT PREPARATION ON PAGE 16

Top of Unit prior to installation of the flue. The packaging material has been removed



1. 6" starter flue fitted. Note the crimped end is down (into unit)



2. 6" Flue fitted. Note: crimped end is down. Must connect active pipe using stainless steel rivets or self drilling screws. 2 for each join..

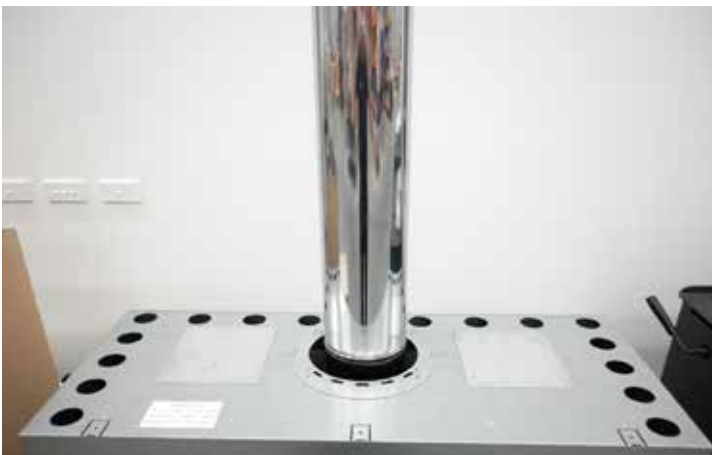

3. 8" and 10" galvanised skin fitted Air cooled bracket positions 8" inside shell and 10" outside shell – note crimped end up on outer is down



4. 8" & 10" galvanized flue skin fitted with aircooling bracket



5. Air cooled bracket and pipe fitted to unit



installation

6. Top of 8" and 10" galvanized flue skins.

Note: Ventilation at top of outer flue where it meets cowl – must be vented to allow heat escape.

Note: 8" skin will be shorter than 10" at top – this is fine as allows 8" to vent into outer and cowl.



At this stage of the installation the unit is installed with the flue system and any optional kits. The next step is to install and set the support flanges in the correct position to accommodate the front wall framing and finishing.

FLUE REQUIREMENTS

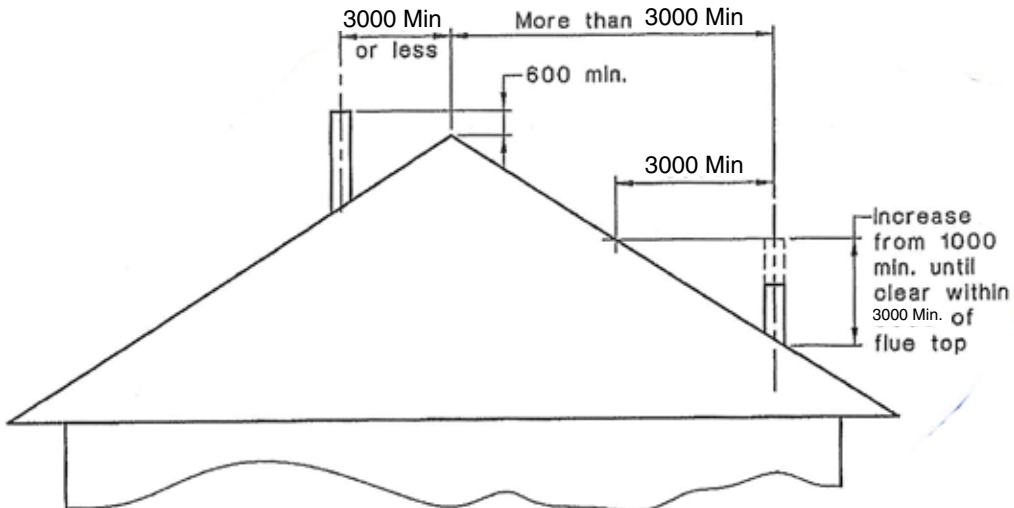
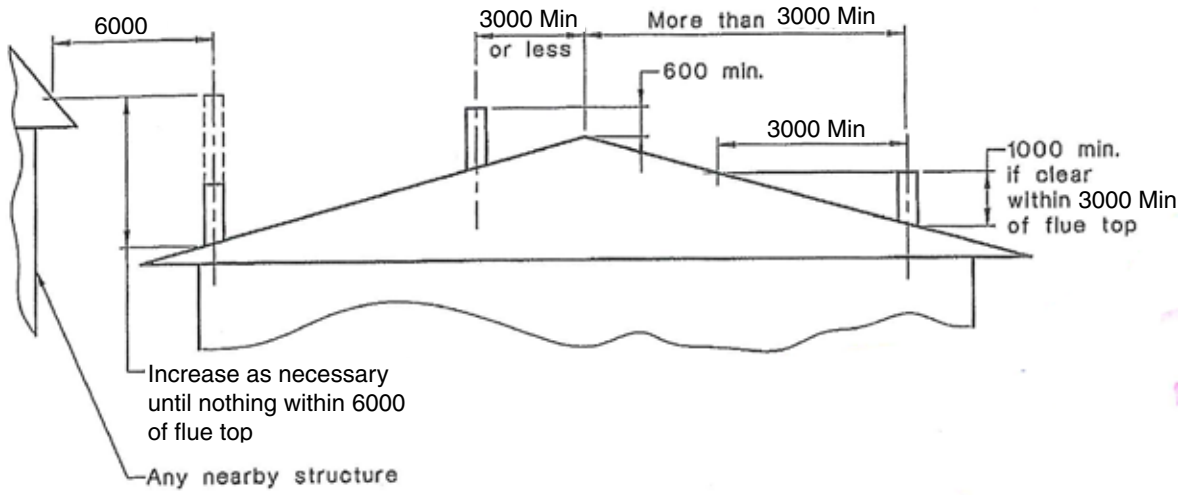

THE FLUE PIPE SHALL EXTEND NOT LESS THAN 4.6 M ABOVE THE TOP OF THE FLOOR PROTECTOR / HEARTH.

NOTE: INSTALLATION MUST BE CARRIED OUT BY A LICENSED INSTALLER IN ACCORDANCE WITH AS/NZS 2918:2018

FLUE REQUIREMENTS

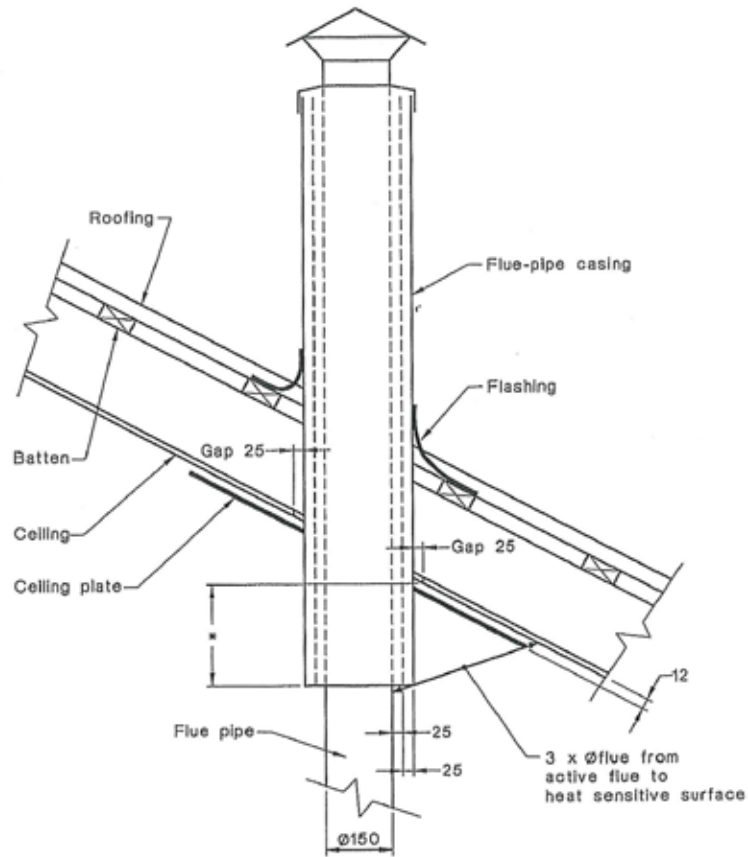

Typical Example of a Sloped Ceiling Penetration

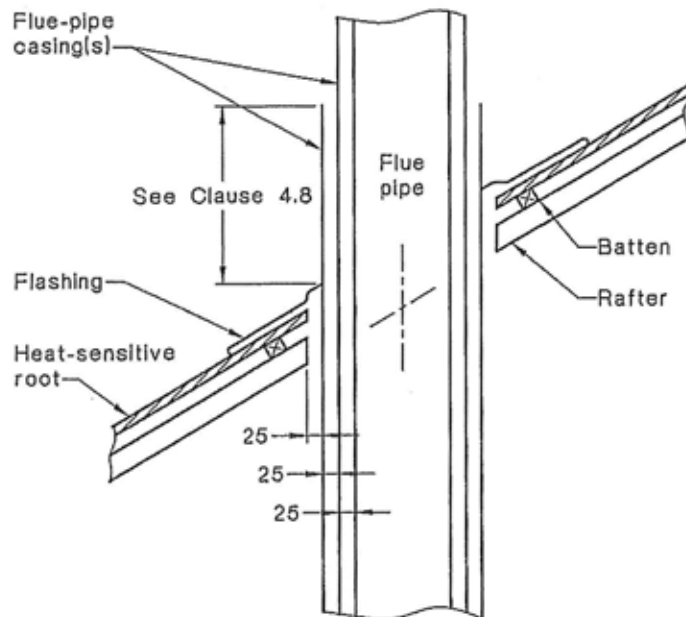

Example of Roof Penetration

INSTALLATION INSTRUCTIONS

UNIT PREPARATION/FRAMING/30MM-50MM FINISHING TRIM

BEFORE INSTALLING ENSURE THE FOLLOWING:

READ THE ENTIRE MANUAL

EVALUATE THE LOCATION OF YOUR FIREPLACE AND LOCATION OF OPTIONAL COMPONENTS SUCH AS THE OPTIONAL FAN KITS AND OUTSIDE AIR KIT.

DETERMINE WHAT THE THICKNESS OF YOUR DESIRED NON-COMBUSTIBLE FINISHING MATERIALS INCLUDING THE REQUIRED NON-COMBUSTIBLE BOARD. THIS PREDETERMINED THICKNESS WILL DICTATE THE CAVITY DEPTH, POSITION OF THE SUPPORT FLANGES, FRAMING AND OVERALL FINAL LOOK OF YOUR FIREPLACE.

The unit comes standard with support flanges and clean edge frame installed. Clean edge frame comes with 20mm standoff brackets.

MAXIMUM THICKNESS OF NON-COMBUSTIBLE FINISHING MATERIAL: 32MM

1. Determine the location of the fireplace, flueing location and locations of the options such as the fan kit and outside air.
 - 1.a. Install Non-combustible Hearth as per Hearth requirement listed on page 9.
 - 1.b. Construct your base frame. Please see BASE FRAME instructions on page 10. The base frame is required TO RAISE THE UNIT in order to meet the 300mm clearance to the finished floor.



2. Position your base frame in the predetermined location of fireplace. Level then mark the position of the base frame. Remove the frame and set aside.
3. Frame out back wall if required and side walls only of the fireplace cavity. DO NOT FRAME FRONT WALL. The back and side walls of the cavity can be constructed using timber. Please refer to page 8 and 9 for clearances and cavity depth.
4. Reinstall the base frame and secure to the floor.
5. If using optional outside air kit please refer to page 21. The optional air kit adapter must be installed prior to the unit being positioned on to the base frame.
6. Install the fireplace on the base frame. Secure unit to the base frame

Below is the view of the top of the unit prior to installation of the flue. The packaging material has been removed.

Please refer to Flue requirements on page 11. Install your flue system.

7. After flueing has been installed, complete the install of your optional kits such as fan and/or outside air kit, as per page 20.

INSTALLATION INSTRUCTIONS

UNIT PREPARATION/FRAMING/30MM-50MM FINISHING TRIM

8. Install the support strips. The unit comes with four support strips. The top, left and right side are all the same and the bottom one is the smaller piece. Install the top and side support strips with the slotted side on the unit. The left and right should **NOT** be touching the floor. Secure with the screws provided. Install the bottom small support flange and secure to the left and right vertical ones. **DO NOT TIGHTEN SCREWS** on the top, left and right support flanges.



Support strip installed with slotted side on unit. The slot allows the movement of the support strip to be adjusted depending upon thickness of finish material.

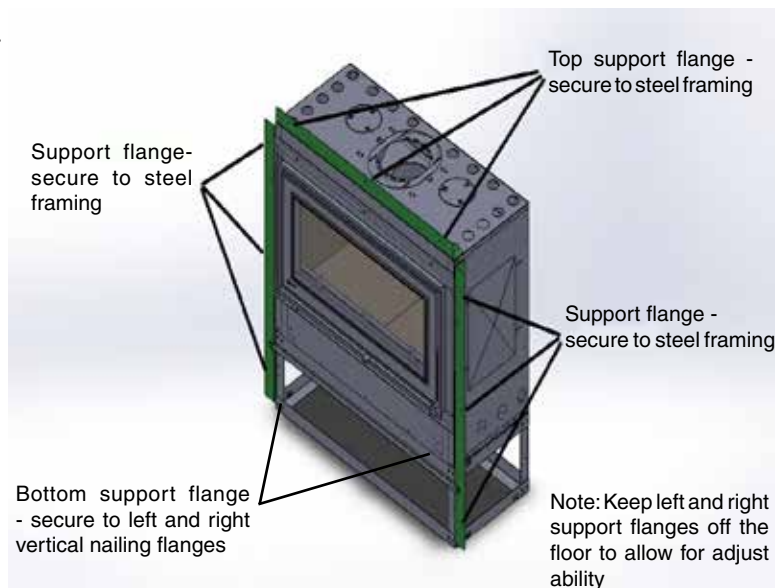

INSTALLATION INSTRUCTIONS

UNIT PREPARATION/FRAMING/30MM-50MM FINISHING TRIM

9. Position the support flanges to the pre-determined thickness of the finish material. The non-combustible finish materials and non-combustible board are to sit up to the clean edge trim with standoff brackets. Using the scrap pieces as a gauge position them so they are flush with the front edge of the clean edge frame. Then slide the top support flange so it is tight against the back of the non-combustible board/finish material and tighten the screws. Do the same to the left and right sides.
THE SUPPORT FLANGES ARE NOW SET TO THE THICKNESS OF THE FINISH MATERIAL

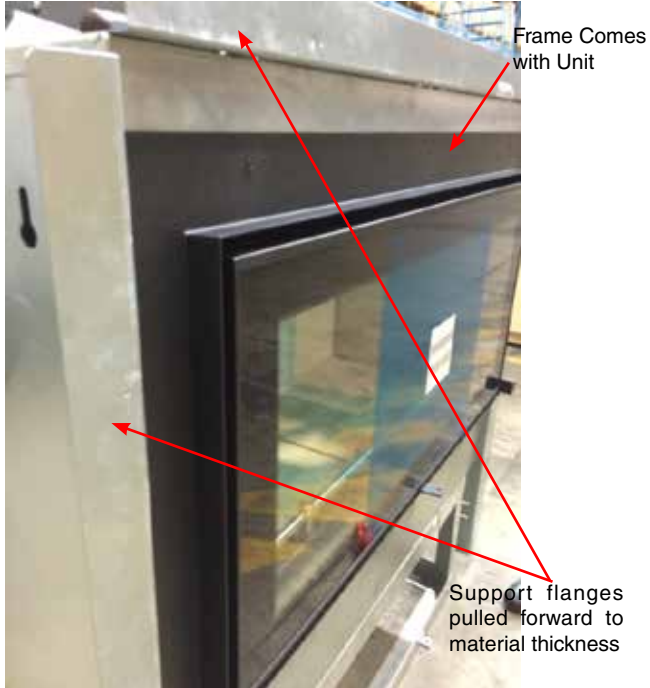

10. Install the steel framing: The front wall requires to be constructed of non-combustible materials including the framing. Steel stud framing must be used. Install the left and right vertical steel frame and secure to the support flanges. Position the steel frame behind the support flange. Install the top horizontal steel frame and secure to the top support flange.



11. Finish constructing the remainder of the front wall using steel framing. Ensure the framing is level and plumb and there is enough framing to secure the required non-combustible board.
12. Install the non-combustible board. Ensure there are no seams on the top and sides as these areas get extremely hot. Having no seams on the top and side will prevent cracking. Use only high heat non-combustible board.
13. Install the final layer of non-combustible finishing material such as tile, slate, Etc. ENSURE ALL ADHESIVES/ GLUES/ ETC ARE HIGH HEAT RESISTANT. ALLOW BONDING AGENTS TO CURE PROPERLY BEFORE FIRING UNIT.
14. Install the 30/50mm finishing trim.

OPTIONAL FAN KIT INSTALLATION

LISTINGS AND CODE APPROVALS

This Fan Kit has been approved for use with Montrose L850B ST and Montrose -NZ L850B-1.

Check with your local building code agency before you begin your installation to ensure compliance with local codes, including the need for "permits" and follow-up inspections. If any problems are encountered regarding code approvals, or if you wish clarification on any of the instructions contained here, contact your local dealer.

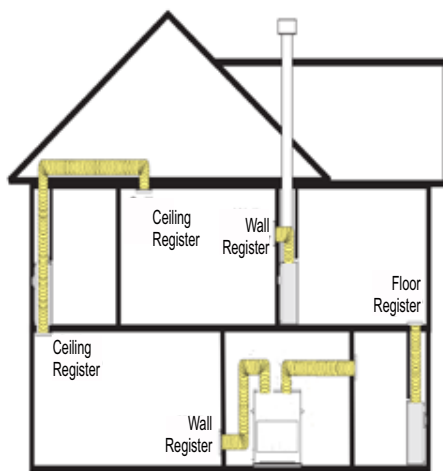

Diagram 1: Guide for possible air duct runs and locations. Keep duct length and number of bends to a minimum. **Maximum duct length is 9.0m.** The Fan Kit 946-591 does not contain any flueing a separate Flex Kit is required 946-596. This Flex Kit contains one length of 4.5 metres of flex flueing. If 9.0 metres of flex ducting is required you will need to purchase an additional Flex Kit.

Item No.	Description	No	Description
1	240V Fan Assembly	7	Aluminum Flex 4.5m Long x 150 mm Round Diameter
2	Duct Flange-Fan	8	Duct Mounting Plate
3	Adapter Round to Oval	9	Duct Flange-Stove
4	Angle Bracket	10	Sidewall Grille
5	Junction Box	11	Cable Clamp
6	Wall Adapter Plate		

GENERAL INFORMATION

The Fan Kit increases the effectiveness of your fireplace by dispersing warm air from the fireplace to remote locations in the same room or other rooms in your home.

Up to two kits may be installed on the fireplace.

Important Installation Notes

- 1) The appliance installation must conform with local codes and installation codes.
- 2) The appliance when installed, must be electrically grounded in accordance with local codes.
- 3) This kit is tested and safe when installed in accordance with this installation manual. Please read all instructions before starting installation and follow all instructions carefully during installation.
- 4) Installation of this kit must be performed by a qualified service technician.
- 5) The Fan Kit must be installed only as specified. Any modifications of the kit or components will void the warranty and may cause a fire hazard.
- 6) Plan the location of the fireplace and the warm air duct runs, see diagram 1 as a guide for possible duct runs and locations.

NOTE: Airflow through the duct system is affected by the duct length and number of bends. Keep the length and bends to a minimum to maximize performance.

MINIMUM FRAMING CLEARANCES

- * Wall studs must be 407mm on centre for mounting fan housing.
- * Fan Housing: Maintain a (6mm) clearance from fan housing to combustible material.
- * Wall Registers must be 102mm above floor and / or 102mm below ceiling.

- 1) Determine the location of the air register/fan housing assembly. Cut a 121mm x 406mm hole between framing members (wall studs or floor joists). Maintain a 6mm clearance from fan housing to combustible material. See Framing Clearances section.

Minimum Fan Duct Clearances

The fan duct requires a minimum of 25mm clearance to combustibles.

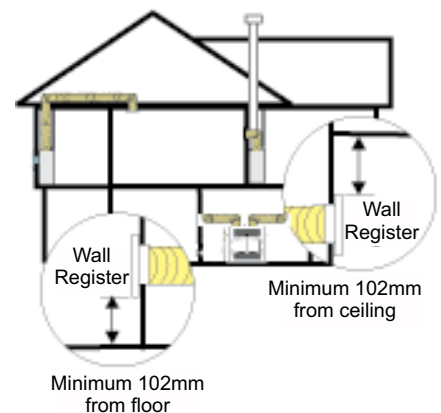

OPTIONAL FAN KIT INSTALLATION

NOTE: Installation of Fan Kit should be done prior to installation of the wall.

- 2) Mount and secure the fan housing assembly to framing members, the front of the fan housing will protrude 12.7mm out of the wall so it may be finished with drywall, etc. See Diagram 2
3. Install the air duct run. Secure the duct to the duct collar on the unit and the fan housing with 3 screws per end.

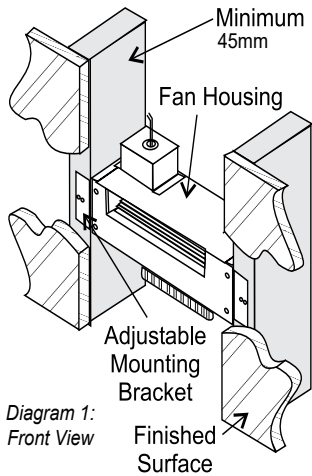

Diagram 1:
Front View

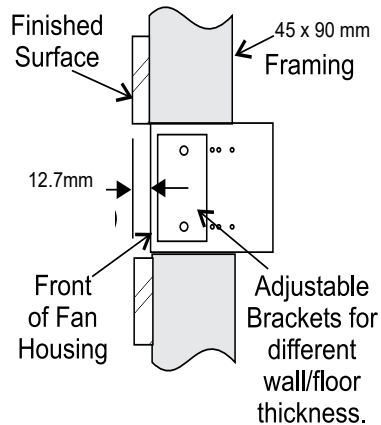
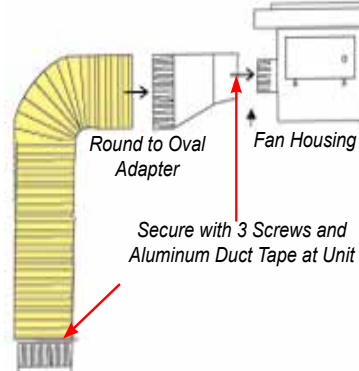

Diagram 2: Side View - Secure fan housing to minimum 45mm framing.

Round Air Duct: Attach the 152.4mm round air duct (supplied) to the fireplace collar and run the duct to the fan housing. Attach the round-to-oval adapter to the fan housing and the air duct to the adapter

Air Duct



4. Install the On/Off switch in a convenient location. This switch controls the fan operation.
NOTE: Variable speed or Rotary 3 speed switch (not supplied) can be fitted.

5. Wire up the fan, wall switch and power supply per local codes. See wiring diagram as reference.
*Electrician to supply wiring

6. Screw fan junction box to the fan housing.

7. Screw the Register Adapter Frame and the Air Register to the Fan Housing See Diagram 4.

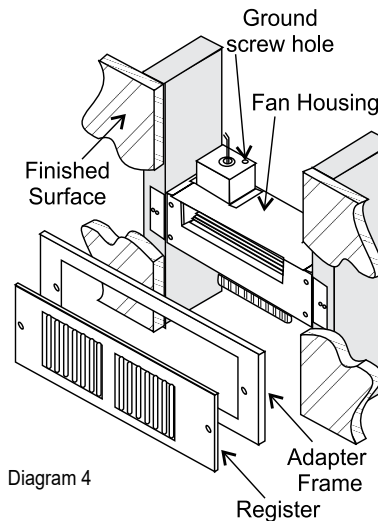
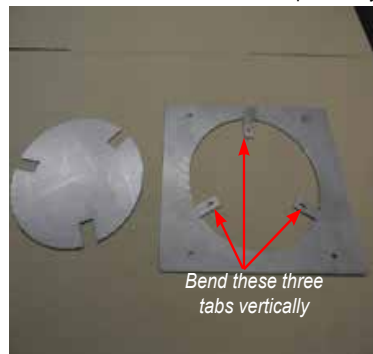

Diagram 4

- 8) Within the fan kit there is a flat plate with a knockout. Take the plate and remove the knockout and bend the three tabs up vertically.



- 9) Secure the collar within to the three tabs using the screws provided.



- 10) Remove the cover plate on the top of the unit. If installing two fans, remove both. Attach the knock off plate and collar to the same positions on the unit.



- 11) You are now ready to attach the other end of the fan ducting to the unit. Slide the ducting over the collar and secure with screws provided.



- 12) Final step is to double check the fan ducting connections at both the unit and fan. Next ensure there is a minimum of **25mm clearance to combustibles**. Strap and secure the fan duct. Double check the operation of the fan and all electrical work is completed.

OPTIONAL FAN KIT INSTALLATION

FAN DUCT EXTENSION KIT

1. Attach the connecting collar to the duct that came with the duct kit. Use the screws provided.



2. Attach the 4.5m duct within this kit to the connecting collar on the opposite end with the screws provided. Extend the flex to the desired length.



WIRING DIAGRAM

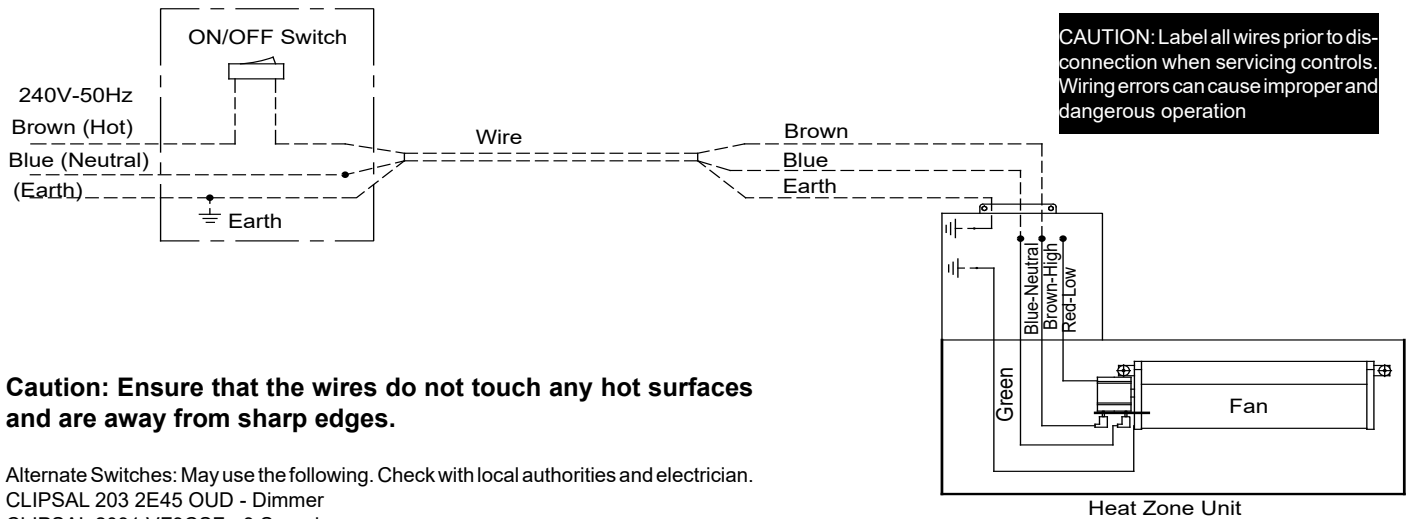

Installation of wiring and switching must be carried out by a qualified electrician

OPTIONAL OUTSIDE AIR KIT INSTALLATION

When installing the outside air kit please ensure your pedestal base the unit sits on is hollow in the centre. The outside adapter attaches to the bottom of the unit. It is recommended not to down-size the outside air ducting.

1. Evaluate your base frame. Ensure there is adequate space to allow the hook up of the adapter beneath the unit.
2. Gently lay the unit on its back to access the bottom. Remove the cover plate located on the bottom of the unit accessing the primary air control.

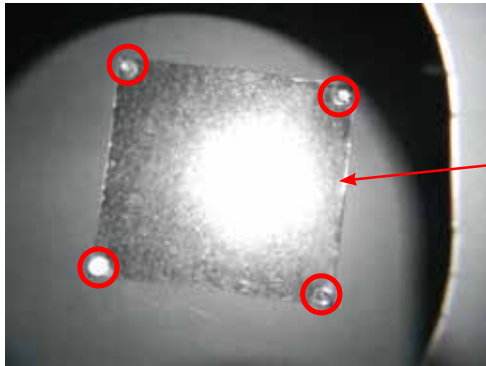

Remove screws and Cover Plate



View with Cover Plate removed and unit adapter installed.

3. Install the adapter ensuring it is centred on the primary air opening. Secure in place with the provided screws.

NOTE: The larger diameter end requires to be sitting below the unit. Insert adapter with smaller diameter end.



Large Diameter End to be Below Unit

4. Stretch the 150 mm diameter flex out to the distance required. Attach the 150 mm diameter flex to the large diameter part that is protruding below the bottom of the unit. Use the screws provided.



5. Cut a hole on your pre-determined outside wall to allow the fresh air hood to be installed. Install and secure the fresh air hood. Caulk around the flange to ensure tight seal against exterior of home. Join the 150 mm diameter flex from the unit adapter to the fresh air hood on the inside of the wall.



BRICK INSTALLATION

Firebricks are not in place at time of delivery to prevent damage.

Place 3 rear bricks at back of fireplace firstly.

Then place 2 side bricks in position left and right.

3 x Baffle Bricks need to be placed in position at top of fire.

Finally insert 2 firebricks on the base of the firebox.

Firebricks are included as an integral part of the unit and not only enhance operating performance hence compliance of the unit but also to extend the life of your firebox.

These must be replaced if damaged in any way **in order not to Void the Warranty**

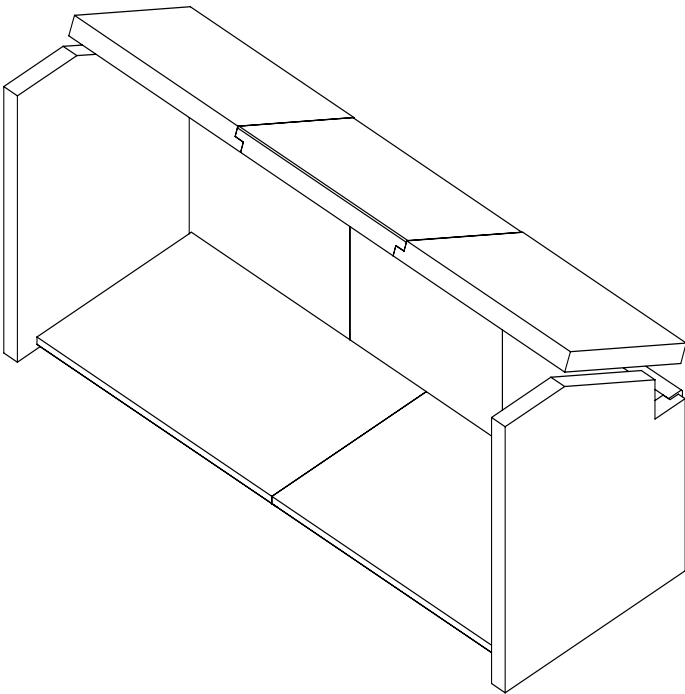

APPLIANCE MAINTENANCE

CREOSOTE

When wood is burned slowly, it produces tar and other organic vapours, which when combined with moisture, form creosote. The creosote vapours condense in the relatively cool flue of a slow burning fire. As a result, creosote residue accumulates on the flue lining. When ignited, this creosote can result in an extremely hot fire.

WARNING: Things to remember in case of a flue fire:

1. Close all draft and damper controls.
2. CALL THE FIRE BRIGADE.

Ways to Prevent and Keep Unit Free of Creosote

- 1) Burn heater with the draft control wide open for about 10-15 minutes every morning during burning season.
- 2) Burn heater with draft control wide open for about 10 - 15 minutes every time you apply fresh wood. This allows the wood to achieve the charcoal stage faster and burns up any unburned gas vapours which might otherwise be deposited within the system.
- 3) Only burn seasoned wood! Avoid burning wet or green wood. Seasoned wood has been dried at least one year.
- 4) A small hot fire is preferable to a large smouldering one that can deposit creosote within the system.
- 5) The flue should be inspected at least once every two months during the heating season to determine if a creosote buildup has occurred.
- 6) Have flue system and unit cleaned by competent flue sweeps twice a year during the first year of use and at least once a year thereafter or when a significant layer of creosote has accumulated (3 mm/) it should be removed to reduce the risk of a flue fire.

ASH REMOVAL

During constant use, ashes should be removed every few days.

Safety Precautions

- 1) Do not allow ashes to build up to the loading doors. Only remove ashes when the fire has died down. Even then, expect to find a few hot embers.
- 2) Please take care to prevent the build-up of ash around the start-up air housing located inside the heater box, under the loading door lip.
- 4) The firebricks are brittle and can be damaged if pieces that are too large are forced/thrown in.
- 5) Shovel out the ash into an appropriate container for removing ashes. The ash can still have hot embers so dispose of carefully. A large metal pail designed for ash removal is recommended. It should come with a tight fitting lid and wire handle for carrying.
- 6) Leave about 25mm of ash in the firebox. It will make it easier to build and maintain a fire. The hot coals tend to nestle into the ash and glow, adding more heat to the fuel and reflecting the heat back into the fire.

GLASS INSTALLATION

1. Remove the door from the heater by lifting it up off hinge pins.
2. Remove the top glass retainer.
3. Loosen the bolts on the bottom retainer.
4. Loosen screws on the left and right side retainers.
5. Remove the glass carefully and keep it aside.
6. Install a new gasket onto the window frame.
7. Install the new glass.
8. Reverse steps 1-4 to reassemble the unit.

Replacement Glass Part Number: 2510221

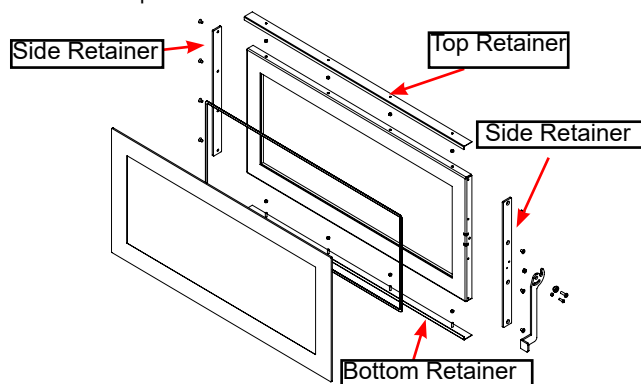

MAINTENANCE

It is very important to carefully maintain your heater, including burning seasoned wood and maintaining a clean heater and flue system. Have the flue cleaned before the burning season and as necessary during the season, as creosote deposits may build up rapidly. Moving parts of your heater require no lubrication. The integrity of all heater parts including baffle plates, cast iron liners, fire bricks, air tubes, air bars, door rope seals, and door glass is imperative for the correct operation and longevity of your Regency Wood heater. They should be inspected on a regular basis and replaced if they show any signs of undue wear or damage. Failure of any of these components can damage the heater and void warranty.

GLASS MAINTENANCE

Your Regency heater is supplied with Neoceram ceramic glass that will withstand the highest heat that your unit will produce. In the event that you break your glass by impact, purchase your replacement from an authorized Regency dealer only, and follow our step-by-step instructions for replacement.

Allow the heater to cool down before cleaning the glass, do not clean the glass when it is hot and do not use abrasive cleaners as both will damage the glass.

DOOR LATCH ADJUSTMENT

The door latch may require adjustment as the door gasket material compresses over time.

Follow the steps below to allow the latch to be moved closer to the door frame, causing a tighter seal

- 1) Unscrew latching sleeve.
- 2) Move door latch back towards the firebox by a few millimetres.
- 3) Retighten latch bolts.

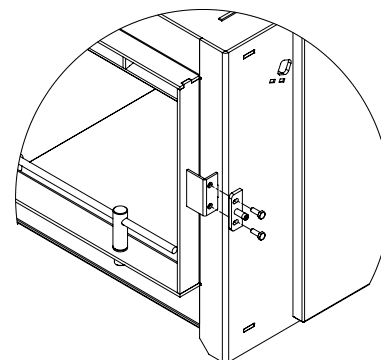

TROUBLESHOOTING

Symptom	Possible Cause	Solution
Fire will not start or starts slowly	The combustion air control is closed, or insufficient combustion air is reaching the fire.	Ensure that the air control is open and that the air inlet is free from debris. If necessary crack open the fireplace door until the fire is started.
	Wet or insufficient kindling was used to try to start the fire	Use drier kindling and paper if necessary to start the fire. The initial burn helps to warm the flue and establish a proper draft.
	Trying to burn wet "fuel" wood will slow down the start	Use drier "fuel" wood for the fire, and allow more air space to start the fire. Wood should have a moisture content of 15-20% for best results. Use more kindling to dry the "fuel" wood.
	A negative air pressure in the home which can reverse or impede the natural flow of flue gasses.	Crack open a door or window, and turn off all exhaust devices. Typically increasing flue height will help to increase fireplace draw.
	A dirty or blocked flue or blocked air inlets can reverse or impede the natural flow of flue gasses.	Inspect the flue and fireplace for buildup or blockage and as necessary have the flue and fireplace cleaned.

Dirty Glass	The air control may have been closed to soon, slowing down the burn of the fire, which will allow deposits to stick to the glass	Leave the air control open longer, at least 10-15 minutes every time you insert fresh wood, to ensure the fire has reached optimum temperature and properly established a draft.
	Burning wet wood will slow the burn of the fire, produce more smoke, and allow unburned fuel to stick to the glass.	Use drier wood for the fire. Wood should have a moisture content of 15-20% for best results.
	A dirty flue, or an improperly sized or installed vent, will impede the flow of flue gasses slowing down the fire and allowing unburned fuel to stick to the glass.	Inspect the flue for buildup or blockage and to ensure that the proper size and configuration of venting was installed (refer to the Unit's manual) and as necessary have the flue cleaned, repaired, or replaced.
	An inadequate supply of combustion air will slow the burn and allow deposits to stick to the glass.	Ensure that air intakes are clean and clear of any debris. It may be necessary to install an outside air kit to provide adequate air supply.
	Worn gaskets will change the airflow of the fireplace and can allow deposits to stick to the glass.	Inspect and replace any worn gaskets to ensure proper airflow patterns within the unit.

Symptom	Possible Cause	Solution
Fire burning too fast	The door may have been left open, or the door latch may need adjustment.	Ensure that the door is properly closed and that when latched that the latch holds the door closed. If necessary adjust the latch (refer to the manual).
	Worn gaskets and/or an improperly installed ash plug (freestanding units) will change the airflow of the fireplace and can increase the speed of the burn by bypassing the air control system.	Inspect and replace any worn gaskets to ensure proper airflow patterns within the unit. Remove ash plug and clean the plug and surrounding area, then re-seat the plug into the bottom of the heater.
	The air control may have been left open, allowing the fire to burn faster	Once the fireplace has reached optimum temperature, adjust the primary air control to maintain optimum burn.
	Soft, rotten and extremely dry wood will burn quickly.	As much as possible use a dense and seasoned wood, preferably at 15-20% moisture content. If necessary mix newer, less seasoned wood with fuel that may be burning too fast.
	An overly tall flue may create an excessive draft, which will increase the speed of the burn.	Although heater pipe dampers are not recommended in today's EPA Certified units, it is possible to install a flue damper in the pipe at a height of 18" above the flue of the unit. This will restrict the flue gasses and help decrease the speed of the burn.
CAUTION If the body of your unit starts to glow, you are overfiring the unit. STOP loading fuel immediately and close the draft control until the glow has completely subsided.		

OPERATING INSTRUCTIONS

With your unit now correctly installed and safety inspected by your local authority, you are now ready to start a fire. Before establishing your first fire, it is important that you fully understand the operation of your draft control.

WARNING: ANY MODIFICATION OF THE APPLIANCE THAT HAS NOT BEEN APPROVED IN WRITING BY THE TESTING AUTHORITY IS CONSIDERED AS BREACHING AS/NZS 4013.

WARNING: DO NOT USE FLAMMABLE LIQUIDS OR AEROSOLS TO START OR REKINDLE THE FIRE.

WARNING: DO NOT USE FLAMMABLE LIQUIDS OR AEROSOLS IN THE VICINITY OF THIS APPLIANCE WHEN IT IS OPERATING.

WARNING: DO NOT STORE FUEL WITHIN HEATER INSTALLATION CLEARANCES. CAUTION: THIS APPLIANCE MUST BE MAINTAINED AND OPERATED AT ALL TIMES IN ACCORDANCE WITH THESE INSTRUCTIONS.

WARNING: OPEN AIR CONTROL (AND DAMPER WHEN FITTED) BEFORE OPENING FIRING DOOR.

CAUTION: THIS APPLIANCE SHOULD NOT BE OPERATED WITH A CRACKED GLASS.

CAUTION: THIS APPLIANCE SHOULD BE MAINTAINED AND OPERATED AT ALL TIMES IN ACCORDANCE WITH THESE INSTRUCTIONS.

CAUTION: THE USE OF SOME TYPES OF PRESERVATIVE-TREATED WOOD AS A FUEL CAN BE HAZARDOUS.

For safety reasons and in order to avoid over firing of your unit do not burn your fire with the door open or ajar

AIR SLIDE CONTROL

Both the primary and air wash drafts are controlled by the control rod located at the bottom of the unit (when facing the unit). To increase your draft - pull right to open, and to decrease - push left. All units have a secondary draft system that continually allows combustion air to the induction ports at the top of the firebox, just below the flue baffle.

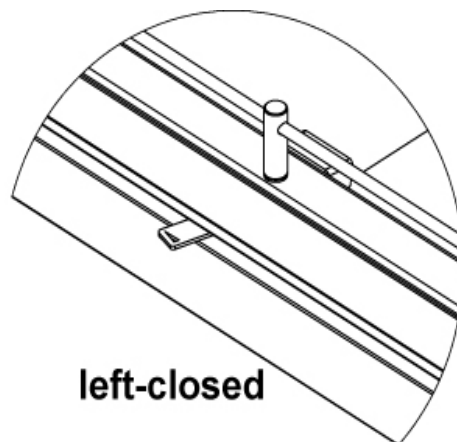
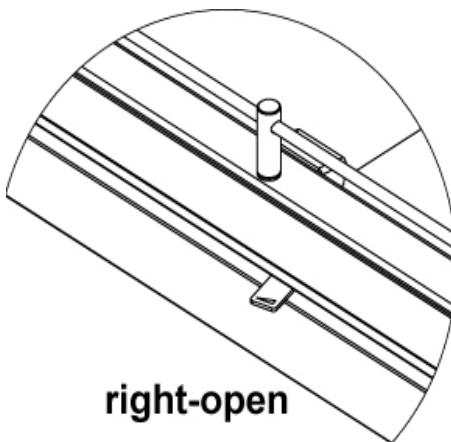

WARNING: To build a fire in ignorance or to disregard the information contained in this section can cause serious permanent damage to the unit and void your warranty!!

FUEL REQUIREMENTS

BURN ONLY HARDWOOD TIMBER THAT HAS BEEN SEASONED AND THE MOISTURE CONTENT OF THE LESS THAN 20%.

FRESHLY CUT WOOD REQUIRES AT LEAST 12-18 MONTHS TO BE READY FOR USE.

USING SEASONED TIMBER WITH PROPER MOISTURE CONTENT WILL ENSURE DRAFT, CLEAN GLASS, EFFICIENCY AND HEAT OUTPUTS.

CAUTION: BURN UNTREATED AIR DRIED SEASONED HARDWOODS ONLY. OTHER MATERIALS SUCH AS WOOD PRESERVATIVES, METAL FOILS, COAL, PLASTIC, GARBAGE, SULPHUR COAL, BRIQUETTES OR OIL WILL DAMAGE THE FIRE AND ATMOSPHERE AND VOID THE WARRANTY.

"This wood heater is designed to burn natural wood only. Higher efficiencies and lower emissions generally result when burning air dried seasoned hardwoods, as compared to green or freshly cut hardwoods."

DO NOT BURN (WILL VOID WARRANTY)

- Treated wood
- Tea Tree
- Oil based woods
- Coal
- Garbage
- Cardboard
- Solvents
- Colored Paper
- Trash

SAVE THESE INSTRUCTIONS

WOOD STORAGE

Store wood under cover, such as in a shed, or covered with a tarp, plastic, tar paper, sheets of scrap plywood, etc., as uncovered wood can absorb water from rain or snow, delaying the seasoning process.

WARNING: Do not over-fire this unit and always open the door slowly when reloading

LIGHTING THE APPLIANCE AND THE FIRST FEW FIRES

When your installation is completed and inspected you are ready for your first fire.

1) Split wood into 3 stacks: Kindling, Start Up, (larger pieces than kindling) and firewood.

2) Open draft control fully.

3) Open firebox door and build a small fire using paper and dry kindling on the firebrick base. Secure door on the firebox and wait a few minutes for a good updraft in the flue to establish the fire.

Add start up fuel and spread across the unit. It is important to create airspaces within the pieces of start up fuel for proper ignition and clean combustion. (Leaving the door slightly open will help your fire start more rapidly.)

CAUTION: Never leave unit unattended if door is left open. This procedure is for fire start-up only, as unit may overheat if door is left open for too long.

4) With the draft still in the fully open position add two or three seasoned logs to your fire. Form a trench in the ash bed to allow air to reach the rear of the firebox prior to closing the door.

5) After about 45 minutes, when your wood has begun to burn strongly, adjust your draft control down to keep the fire at a moderate level.

WARNING: Never build a roaring fire in a cold heater. Always warm your heater up slowly!

6) Once a bed of coals has been established on the base of the firebox, you may adjust the draft control to a low setting to operate the unit at its most efficient mode.

7) During the first few fires, keep the combustion rate at a moderate level and avoid a large fire. Only after 5 or 6 such fires can you operate the heater at its maximum setting, and only after the metal has been warmed.

8) For the first few days, the heater will give off an odour from the paint. This is to be expected as the high temperature paint becomes seasoned. Windows and/or doors should be left open to provide adequate ventilation while this temporary condition exists. Burning the heater at a very high temperature the first few times may damage the paint. Burn fires at a moderate level the first few days.

9) Do not place anything on the heater top during the curing process. This may result in damage to your paint finish.

10) During the first few days it may be more difficult to start the fire. As you dry out the firebrick and your masonry flue, the draft will increase.

11) For those units installed at higher elevations or into sub-standard masonry fireplaces, drafting problems may occur. Consult an experienced dealer or mason on methods of increasing your draft.

12) Some cracking and popping noises may be experienced during the heating up process. These noises will be minimal when your unit reaches temperature.

13) Before opening your door to reload, open draft fully for approximately 10 to 15 seconds until fire has been re-established. This will minimize any smoking. Open door slowly.

14) All fuel burning appliances consume oxygen during operation. It is important that you supply a source of fresh air to your unit while burning. A slightly opened window is sufficient for the purpose. If you also have a fireplace in your home, a downdraft may be created by your Regency Heater causing a draft down your flue. If this occurs, slightly open a window near your unit.

CAUTION: If the body of your unit, flue baffle or any part of the flue connector starts to glow, you are over firing. Stop loading fuel immediately and close the draft control until the glow has completely subsided.

15) Green or wet wood is not recommended for your unit. If you must add wet or green fuel, open the draft control fully until all moisture has been dispersed by the intense fire. Once all moisture has been removed, the draft control may be adjusted to maintain the fire.

16) If you have been burning your heater on a low draft, use caution when opening the door. After opening the damper, open the door a crack, and allow the fire to adjust before fully opening the door.

17) The controls of your unit or the air supply passages should not be altered to increase firing for any reason.

18) If you burn the unit too slowly or at too low a setting your unit will not be operating as efficiently as it can. An easy rule of thumb says that if your glass is clean, then your flue is clean and your exhaust is clean. Burn the heater hot enough to keep your glass clean and you won't need to clean your flue as often.

DO NOT LOAD FIREPLACE OR COVER THE REAR SECONDARY TUBE. ENSURE COALS / FUEL ARE BEHIND LOG RETAINER DO NOT OPEN DOOR WITH A ROARING FIRE OR WITH AIR CONTROL IN LOW POSITION. WHEN REFUELING ALWAYS ENSURE AIR CONTROL IS IN HIGH POSITION.

MAIN ASSEMBLY

#	Item #	Description	#	Item #	Description
1	1565000	Firebox Shell	12	1560100A	Cleaning Trim with Standoffs
2	1561000	Firebox Assembly	13	1562500	Door Handle
3	1566000	Door Hinge	14	1567000	Air Damper Inlet
4	1560500	Back Secondary Air Tube	15a	1560030	Top (3) and Rear (3) Bricks
5	1563000	Front Secondary Air Tube	15b	1560040	End (2) and Base (2) Bricks
6	1568000	Log Bar Support Assembly	16	1560019	Door Opening Tool
7	1562007	936-060 5/8" Door Gasket	17	1567003	Air Slide
8	1562100	Door Frame Assembly	18	1569000	Adjustable Door Latch
9	3720301	ETC3010 Glass Gasket	19	1564007	Top Deflector
10	2510221	Black Trimmed Ceramic Glass	20	1634200	30mm Front Trim
11	1562400	Glass Retainer Bracket	21	1560110	50mm Front Trim

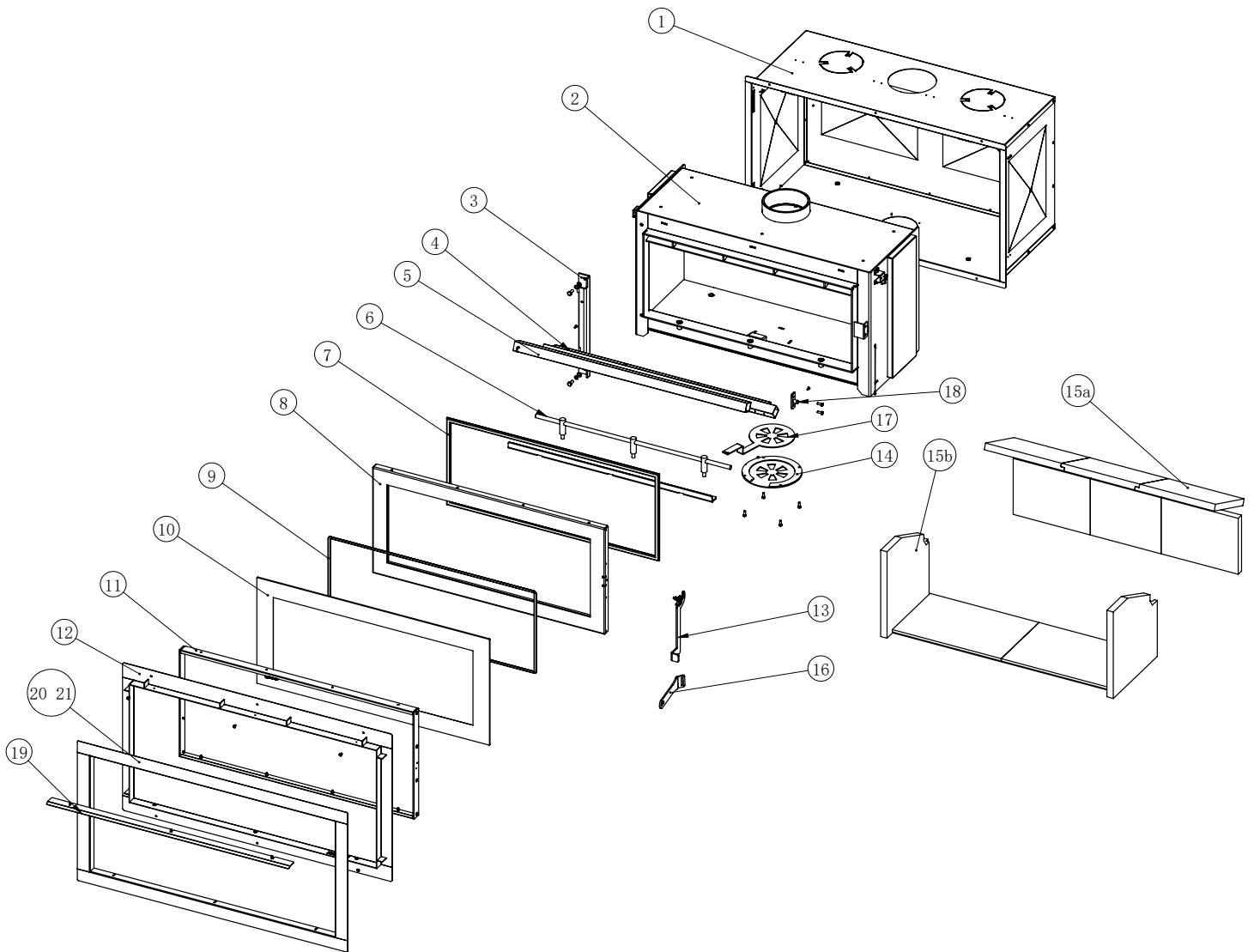

parts list

#	Part	Description
1	910-169/P	Replacement Fan Motor
2	946-001	Duct Flange
3	946-002	Round to Oval Adapter
4	946-007	Angle Bracket
5	946-004	Junction Box
6	946-005-AWT	Wall Adapter Plate White
7	948-357	Adapter Round
8	946-093F	Duct Mounting Plate
9	946-000	Duct Flange Collar
10	946-006	Side Grill White
11	904-687	Connector Clamp

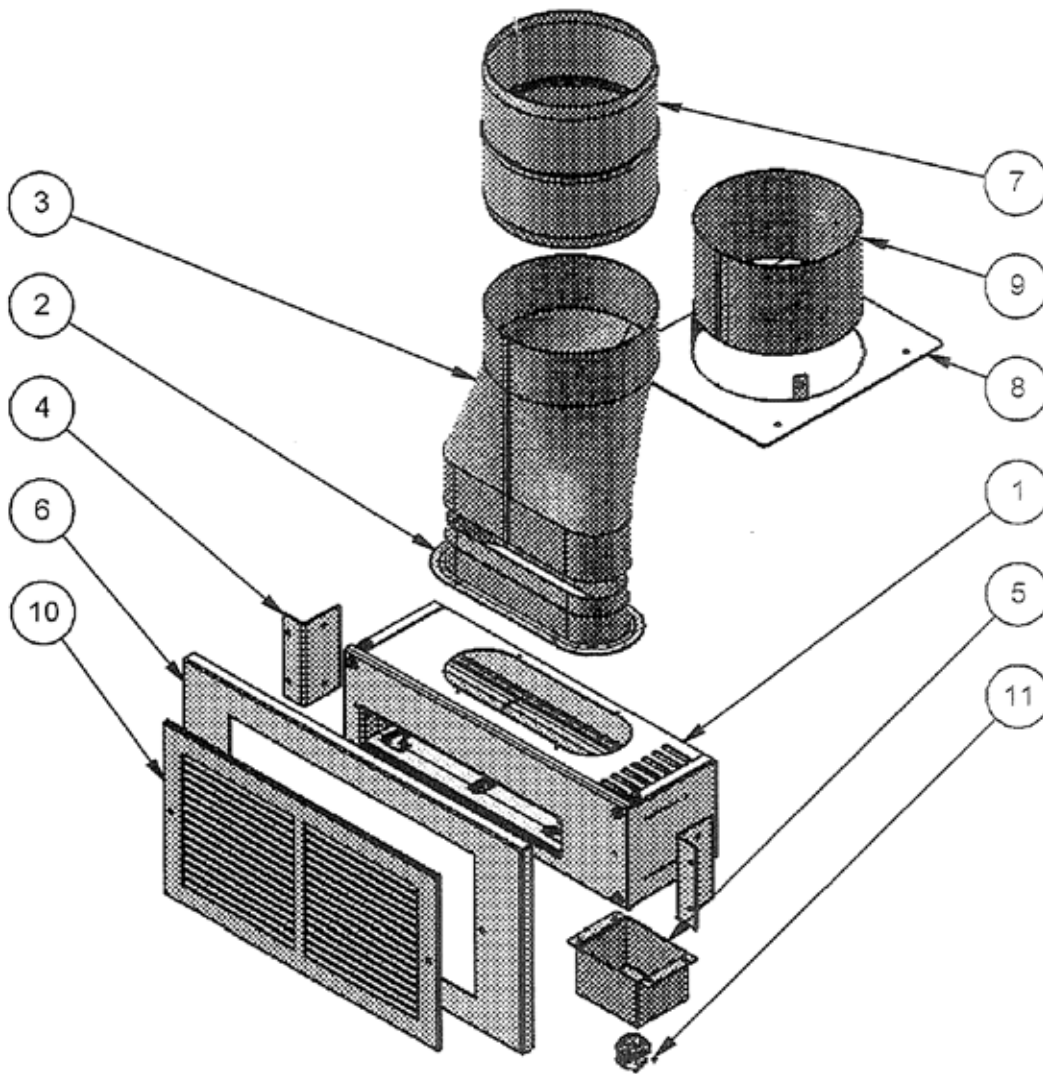

INSTALLATION OF APPLIANCE CHECKLIST

For future reference and to assist in any warranty claim please complete the following information.
In the unlikely event of a problem, contact your installer or dealer for assistance:

APPLIANCE WAS PURCHASED FROM

Name: _____

Address: _____

Telephone Number: _____

MODEL DETAILS

Date Installed: _____

Model Description: _____

Serial Number: _____

INSTALLED BY

Company Name: _____

License Number: _____

Plumber Name: _____

Address: _____

Telephone Number: _____

COMMISSIONING CHECKS (TO BE COMPLETED AND SIGNED)

Is flue system set up in accordance with AS2918

YES NO

Smoke and Spillage test completed

YES NO

Use of appliance and operation of controls explained

YES NO

Clearance to combustible materials checked

YES NO

Installers Signature: _____

Print Name: _____

Date: _____

warranty

Limited Warranty

FPI Fireplace Products International Ltd. (“the manufacturer”) through its wholly owned subsidiary, Fireplace Products Australia Pty Ltd (for Australia and New Zealand customers) and sold under the Regency® brand of fireplace products (collectively referred to herein as “FPI”), extends this Limited Warranty to the original purchaser of this appliance provided the product remains in the original place of installation. The items covered by this limited warranty and the period of such coverage is set forth in the table below.

Some conditions apply (see below).

The policy is not transferable, amendable or negotiable under any circumstances.

Wood Products	Component Coverage				Labor Coverage (Years)
	15 years	2 years	1 year	Warranty	
Welded Firebox Steel	✓				5
All Stainless Steel Components, Smoke Deflectors, Heat Shields etc.			✓		1
Air Tubes			✓		1
Airmate			✓		1
Door handle and latch assembly, all hardware			✓		1
Glass Thermal Breakage Only			✓		1
Accessory Housings			✓		1
All Plating			✓		1
Heatshields			✓		1
All Baffles-Steel, Ceramic, Vermiculite			✓		1
All castings, firebox, surrounds, doors, panels etc.			✓		1
All Electrical, Fans, wiring, switches etc.		✓ (Fan only)	✓		1
Glass - Crazing			✓		1
Flue components			✓		1
Firebricks				Nil	Nil

After the original warranty coverage for any of the parts above have expired, any repair and/or replacement parts purchased by the consumer from FPI or through an accredited distributor or dealer will carry a ninety (90) day warranty (valid only with an original copy of the tax invoice). No labor coverage is included with any repair and/or replacement part.

Replacement parts are limited to one per warranty term. Airtube and baffle replacements are limited to one replacement per term.

Conditions:

Warranty protects against defect in manufacture or FPI factory assembled components only, unless herein specified otherwise. This warranty will only apply to those products which are acquired at the time of this warranty being effective. FPI will not be liable for any damage or loss that falls outside the scope of the warranty.

Any part(s) found to be defective during the warranty period as outlined above will be repaired or replaced at FPI’s option through an accredited distributor, dealer or pre-approved and assigned agent provided that the defective part is returned to the distributor, dealer or agent for inspection if requested by FPI. Alternatively, FPI may at its own discretion fully discharge all of its obligations under the warranty by refunding the verified purchase price of the product to the original purchaser. The purchase price must be confirmed by an original copy of the tax invoice.

The authorised selling dealer, or an alternative authorised FPI dealer if pre-approved by FPI, is responsible for all in-field diagnosis and service work related to all warranty claims. This warranty does not cover dealer travel costs for diagnostic or service work. Dealers may charge homeowner for travel and additional time. Check with your selling dealer in advance for any costs to you when arranging a warranty call. FPI is not responsible for results or costs of workmanship of unauthorised FPI dealers or agents in the negligence of their service work. Additional service fees may apply if you are seeking warranty service from a dealer other than the dealer from whom you originally purchased the product.

At all times FPI reserves the right to inspect reported complaints on location in the field claimed to be defective and determine whether the warranty will apply prior to processing or authorising of any claim. Failure to allow this upon request will void the warranty.

All warranty claims must be submitted by the dealer servicing the claim, including an original copy of the tax invoice (proof of purchase by you). All claims must be complete and provide full details as requested by FPI to receive consideration for evaluation, including proof of maintenance records. Incomplete claims may be rejected. FPI has absolute discretion to assess and determine any warranty claim and may accept or reject a claim as it considers appropriate. Any part or parts of the unit found to be defective will be repaired or replaced at FPI's option, through an accredited distributor or service agent provided that the defective part be returned to the distributor or agent, **Transportation Prepaid**, if requested. **It is the general practice of FPI to charge for larger, higher priced replacement parts and issue credit once the replaced component has been returned to FPI and evaluated for manufacturer defect.**

If a consumer has a unit installed outside an accredited distributor, dealer or pre-approved service agent's service area, or the closest approved service agent is situated more than thirty (30) kilometres from the installation, FPI is not obliged to arrange warranty repairs or shipping/transportation costs. In these cases, the consumer must arrange warranty service with its selling dealer, and shipping, travel and/or additional labor charges will apply.

Unit must be installed according to all manufacturers' instructions as per the manual.

All Local and National required codes must be met.

The installer is responsible to ensure the unit is operating as designed at the time of installation.

The original purchaser is responsible for annual maintenance of the unit, as outlined in the owner's manual. As outlined below, the warranty may be voided due to problems caused by lack of maintenance. Annual maintenance records should be retained.

Repair/replacement parts purchased by the consumer from FPI after the original coverage has expired on the unit will carry a 90 day warranty, valid with a receipt only. Any item shown to be defective will be repaired or replaced at our discretion. No labor coverage is included with these parts.

Exclusions:

This Limited Warranty does not extend to paint, rust or corrosion of any kind due to a lack of maintenance or improper venting, combustion air provision, corrosive chemicals (i.e. chlorine, salt, air, etc.), firebrick (rear, sides or bottom), door or glass gasket, or any other additional factory fitted gasket.

Malfunction, damage or performance based issues as a result of environmental conditions, location, chemical damages, downdrafts, installation error, installation by an unqualified installer, incorrect chimney components (including but not limited to cap size or type), operator error, abuse, misuse, use of improper fuels (such as unseasoned timber, mill-ends, construction timber or debris, off-cuts, treated or painted timber, tea tree, metal or foil, plastics, garbage, solvents, cardboard, coal or coal products, oil based products, waxed cartons, compressed pre-manufactured logs), accidents, lack of regular maintenance and upkeep, acts of God, weather related problems from hurricanes, tornados, earthquakes, floods, lightning strikes/bolts or acts of terrorism or war, which result in malfunction of the appliance are not covered under the terms of this Limited Warranty.

FPI has no obligation to enhance or modify any unit once manufactured (i.e. as products evolve, field modifications or upgrades will not be performed on existing appliances).

Any unit showing signs of neglect or misuse will not be covered under the terms of this warranty policy and may void this warranty. This includes units with rusted or corroded fireboxes which have not been reported as rusted or corroded within three (3) months of installation/purchase. Any alteration to the unit which causes sooting or carboning that results in damage to the exterior fascia or over firing that can cause component or firebox/heat exchanger failure will not be covered by this warranty.

Units which show evidence of being operated while damaged, or with problems known to the purchaser and causing further damages will void this warranty.

Units where the serial no. has been altered, deleted, removed or made illegible will void this warranty.

Minor movement, expansion and contraction of the steel is normal and is not covered under the terms of this warranty.

Freight damages for products or parts are not covered under the terms of the warranty.

Porcelain/Enamel: Absolute perfection is neither guaranteed nor commercially possible. Any chips must be reported and inspected by the authorised selling dealer within three (3) days of installation. Any damage of this type not reported after this time period will be subject to rejection and any related warranty will not apply.

Special Finishes: Expect some changes in color as the product "ages" with constant heating and cooling. The manufacturer warranty does not cover tarnishing, changing colors and/or marks (i.e. finger prints, etc.) after the purchase of the product. Damage from the use of abrasive cleaners is not covered by warranty.

Products made or provided by other manufacturers and used in conjunction with the FPI appliance without prior authorisation from FPI may void this warranty.

INCORRECT INSTALLATION IS NOT COVERED BY WARRANTY. A SERVICE OR CALLOUT FEE WILL BE CHARGED IN THESE CIRCUMSTANCES.

Limitations of Liability:

1. Exclusion of implied terms

The customer may have the benefit of consumer guarantees under the Australian Consumer Law. To the maximum extent permitted by law, all terms, conditions or warranties that would be implied into this Warranty or in connection with the supply of any goods or services by the supplier under law or statute or custom or international conventions are excluded.

2. Limitation of liability

(a) To the maximum extent permitted by law and subject to clauses 1 and 3, the supplier's total liability arising out of or in connection with its performance or its obligations pursuant to this Warranty, or arising out of or in connection with the supply of specific goods or services (including pursuant to or for breach of this Warranty, under statute, in equity or for tort, including negligent acts or omissions) is limited as follows: (i) the supplier shall have no liability to the customer for any Consequential Loss; (ii) without limiting the effect of clause 2(a)(i), the supplier's total aggregate liability for Loss, however arising, shall not exceed the GST exclusive aggregate price paid by the customer to the supplier for the specific goods or services that gave rise to the Loss in question.

(b) The limitations and exclusions in this sub-clause do not apply to the extent that any Loss is directly attributable to: (i) the personal injury or death caused by the supplier's default, breach of this Warranty or negligence; or (ii) fraud by the supplier.

(c) Each party must take reasonable steps to mitigate any Loss it suffers or incurs.

3. Limitation of liability under Australian Consumer Law Guarantees

(a) To the extent that goods supplied by the supplier are not goods of a kind ordinarily acquired for personal, domestic or household use and the customer is deemed to be a consumer for the purposes of section 64A of the

Australian Consumer Law, the customer agrees that the supplier's liability for a failure to comply with a consumer guarantee that the customer may have a benefit under the Australian Consumer Law (other than a guarantee under sections 51 (title), 52 (undisturbed possession) and 53 (undisclosed securities)), is limited to, at the option of the supplier, one or more of the following: (i) replacement of the goods or the supply of equivalent goods; (ii) the repair of the goods; (iii) the payment of the cost of replacing the goods or of acquiring equivalent goods; or (iv) equivalent goods; or (v) the payment of the cost of having the goods repaired.

(b) To the extent that services supplied by the supplier are services other than services of a kind ordinarily acquired for personal, domestic or household use or consumption, the supplier's liability for failure to comply with a consumer guarantee that the customer may have the benefit of is limited to, at the option of the supplier: (i) the supply of the services again; or (ii) the payment of the cost of having the services supplied again.

4. Subject to Change

This Limited Warranty is given at the time of sale and purchase of the relevant fireplace product. The terms of this Limited Warranty may be amended from time to time by FPI in accordance with changes to business practices, consumer laws or other legal requirements. The rights and protections granted under the Limited Warranty are those in force in relation to a fireplace product at the time and in the place of sale of that product, and only those terms will be applicable in respect of that product.

5. Severability

Any term of this Limited Warranty that is invalid or unenforceable in any jurisdiction is to be read down for the purposes of that jurisdiction, if possible, so as to be valid and enforceable, and is otherwise capable of being severed to the extent of the invalidity or unenforceability, without affecting the remaining provisions of this Limited Warranty or affecting the validity or enforceability of that provision in any other jurisdiction.

6. Definitions

For purposes of clauses 1, 2 and 3:

(a) Consequential Loss means loss of expected savings, loss of use, loss of opportunity, loss of profit, loss of revenue, increased financing costs, loss arising from delay, or any consequential, special or indirect loss or damage, whether or not the possibility or potential extent of the loss or damage was known or foreseeable, and whether arising from a claim under indemnity, contract, tort (including negligence), statute or otherwise.

(b) Loss means any expense, cost or damage of any kind and includes Consequential Loss and a fine or penalty imposed by a statutory or other authority.

How to Obtain Warranty Service:

Customers should contact the authorised selling dealer to obtain warranty service. In the event the authorised selling dealer is unable to provide warranty service, please contact FPI by mail at the address listed below. Please include your name, address, purchase date, selling dealer, serial #, type of unit, a brief description of the problem, email and telephone contact information, and a copy of your original tax invoice. A representative will contact you to make arrangements for an inspection and/or warranty service. (See below for Western Australia and/or New Zealand)

Please note Fireplace Products Australia Pty Ltd does not provide installation services.

Fireplace Products Australia Pty Ltd

1 Conquest Way

Hallam, VIC

Australia, 3803

Phone: +61 3 9799 7277

Fax: +61 3 9799 7822

To obtain warranty service in Western Australia and/or New Zealand, please contact one of our authorised distributors in those areas:

Western Australia:

Air Group Australia

28-30 Division St.
Welshpool, WA
Australia, 6106
Phone: (08) 9350 2200
Fax: (08) 9353 4225

New Zealand:

Aber Holdings Ltd

PO Box 10095
Te Rapa, Hamilton
New Zealand, 3241
Freephone: 0800 161 161

Product Registration and Customer Support:

Thank you for choosing a Regency Fireplace. Regency strives to be a world leader in the design, manufacture, and marketing of hearth products. To provide the best support for your product, we request that you complete a product registration form at <http://www.regency-fire.com.au/Customer-Care/Warranty-Registration.aspx> within ninety (90) days of purchase.



Product Registration and Customer Support:

Thank you for choosing a Regency Fireplace. Regency strives to be a world leader in the design, manufacture, and marketing of hearth products. To provide the best support for your product, we request that you complete a product registration form found on our Web Site under Customer Care within ninety (90) days of purchase.

For purchases made in **CANADA or the UNITED STATES:**

<http://www.regency-fire.com/Customer-Care/Warranty-Registration.aspx>

For purchases made in AUSTRALIA:

<http://www.regency-fire.com.au/Customer-Care/Warranty-Registration.aspx>

You may also complete the warranty registration form below to register your Regency Fireplace Product and mail and/or fax it back to us, and we will register the warranty for you. It is important you provide us with all the information below in order for us to serve you better.

Warranty Registration Form (or Register online immediately at the above Web Site):

Warranty Details	
Serial Number (required):	
Purchase Date (required) (mm/dd/yyyy):	
Product Details	
Product Model (required):	
Dealer Details	
Dealer Name (required):	
Dealer Address:	
Dealer Phone #:	
Installer:	
Date Installed (mm/dd/yyyy):	
Your Contact Details (required)	
Name:	
Address:	
Phone:	
Email:	

For purchases made in CANADA:

**FPI Fireplace Products
International Ltd.**
6988 Venture St.
Delta, British Columbia
Canada, V4G 1H4

Phone: 604-946-5155
Fax: 1-866-393-2806

For purchases made in the UNITED STATES:

Fireplace Products US, Inc.
PO Box 2189 PMB 125
Blaine, WA
United States, 98231

Phone: 604-946-5155
Fax: 1-866-393-2806

For purchases made in AUSTRALIA:

**Fireplace Products Australia Pty
Ltd**
1- 3 Conquest Way
Hallam, VIC
Australia, 3803

Phone: +61 3 9799 7277
Fax: +61 3 9799 7822

For fireplace care and tips and answers to most common questions please visit our Customer Care section on our Web Site. Please feel free to contact your selling dealer if you have any questions about your Regency product.

Installer: Please complete the following information

Dealer Name & Address: _____

Installer: _____

Phone #: _____

Date Installed: _____

Serial #: _____

