



# Ei29LCD Insert

## LCD Electric Fireplace Range



Model: Ei29LCD

## Instructions for Use, Installation & Servicing For use in the US (United States) and CA (Canada)

### IMPORTANT

**THE HEATER OUTLET GRILLE BECOMES VERY HOT WHILE IN OPERATION.  
DO NOT COVER THE OUTLET GRILLE OR ANY PART OF THE APPLIANCE.**

For use with 120V 60Hz electricity supply.  
240V supply with hardwire installation only.

Please read these instructions carefully before installation.  
Failure to follow them could result in serious injury.

**SAVE THESE INSTRUCTIONS:** Leave this manual with the appliance, they will be needed when maintenance or servicing is required.

**THIS APPLIANCE MUST BE GROUNDED**

920-781

11.12.24

## CONTENTS

Covering the following models:

MODEL
Ei29LCD

**Important Information and Health and Safety..... 3**

**Operating Instructions..... 6**

**Remote Control ..... 7**

**Installation ..... 15**

Included Items..... 16

Dimensions..... 18

Installation Instructions ..... 22

**Service Instructions ..... 42**

Wiring Diagram..... 46

Spare Parts..... 47

Information Requirement - Electric Heaters..... 49

Warranty ..... 50

Recycling ..... 54

## WARRANTY

This product carries a 1 year warranty. Please note that all warranties are effective from the date of purchase.

Full terms and conditions are detailed in the Warranty Statement on the Regency website [www.regency-fire.com](http://www.regency-fire.com). In the event of any conflict of information the wording on the website shall prevail.

**Important Note:** Should any problems be experienced with your product, claims must first be submitted to the Dealer where the appliance was purchased from who will offer immediate assistance or contact Regency on your behalf.

**Important :** The hand-held transmitter is configured in the factory with a unique signal code. The hand-held transmitter is ready for use once the 2 AAA batteries are installed. If the handset loses it signal or needs to be replaced, see chapter in the servicing section for details.

## DISPOSAL

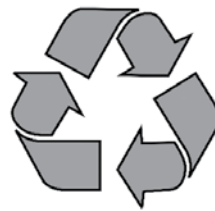

Recycle in accordance with Code of Federal Regulations (CFR), Title 40, Part 273. This device is classified as electrical and electronic equipment. As such, it must not be disposed of with household waste. At the end of its useful life please take this product to an appropriate recycling center or collection point. You can find your nearest recycling drop off point by contacting your locality's waste management office.

### ELECTRICAL SUPPLY

A 120V 12.5A 60Hz supply is required  
 Rated power consumption: EI29: 1400 Watts  
 Plan the location of the appliance so that it will have adequate electric power. A 15 AMP, 60Hz circuit is required for 120V installation. Additional appliances on the same circuit may exceed the current rating of that circuit. A dedicated circuit is not required, but is preferred to prevent circuit breaker trips or fuse failure. Optional 240 VAC 2 phase 15A 60Hz supply can be utilized.  
 Rated power consumption:  
 EI29: 2800 Watt  
 On 240 VAC option, this may only be hardwired.

## IMPORTANT INFORMATION AND HEALTH AND SAFETY



**WARNING: Improper installation, adjustment, alteration, service or maintenance can cause injury or property damage. Refer to this manual. For assistance or additional information, consult a qualified installer.**

When using electrical appliances, basic precautions should always be followed to reduce the risk of fire, electric shock, and injury to persons, including the following:

**Read all instructions before using this appliance.**

**Use this appliance only as described in this manual. Any other use not recommended by the manufacturer may cause fire, electric shock, or injury to persons.**

**DO NOT use outdoors.**

**NEVER** use this appliance in **bathrooms, laundry rooms**, or any other location where the appliance could fall into a **bathtub or pool, become damp, or come in contact with water.**

This product is **not intended** to be a **primary heat source**. It is for supplemental heat only.

Do not locate the appliance immediately **below** a fixed receptacle outlet.

### Electrical Supply Circuit Requirements

Plan the location of the appliance so that it will have adequate electric power. A 15 AMP, 60Hz circuit is required for 120V installation. Additional appliances on the same circuit may exceed the current rating of that circuit. A dedicated circuit is not required, but is preferred to prevent circuit breaker trips or fuse failure.

**Do not cut the ground terminal off under any circumstances.** When connected with 120 volts, the appliance must be electrically grounded in accordance with local codes, current version of CSA C22.1 (in Canada) or in the absence of local codes, with the National Electrical Code ANSI/NFPA 70-1987.

**DO NOT** operate any appliance with a **damaged cord or plug** or after the **appliance malfunctions**, has been **dropped** or **damaged in any manner**. Discard appliance, or return to authorized service facility for examination and/or repair.

This appliance is **hot when in use**. To avoid burns, **DO NOT** let bare skin touch hot surfaces. Keep **combustible materials**, such as furniture, pillows, bedding, papers, clothes, and curtains at least **3.3 feet (1.0 m)** from the **front of the appliance**.

**Extreme caution** is necessary when any appliance is used by or near **children or invalids** and whenever the appliance is left **operating and unattended**.

**DO NOT insert or allow foreign objects to enter any ventilation or exhaust opening**, as this may cause **electric shock or fire**, or **damage the appliance**.

To prevent a possible fire, **DO NOT** block air intakes or exhaust in any manner. Doing so could cause a **fire**. **DO NOT** use on soft surfaces, like a bed, where openings may become blocked.

As the appliance has **hot and arcing or sparking parts inside**. **DO NOT** use it in areas where **gasoline, paint, or flammable liquids** are used or stored.

**AVOID FIRE!** Regularly inspect all air vents to make sure they are free from dust, lint, or other blockage. **Unplug the unit** and clean with a **vacuum ONLY**. **DO NOT** rinse or get wet.

**DO NOT USE** this appliance with any **solid state speed control devices**.

**Risk of electric shock! DO NOT OPEN!** No user-serviceable parts inside!

**NEVER modify this appliance.** Doing so could result in personal injury or property damage. Modification of this fireplace **completely voids all warranties**.

**NEVER leave this appliance unattended. To disconnect appliance, ALWAYS turn controls to "OFF"** then remove plug from outlet or turn off circuit when not in use.

**ALWAYS** turn this appliance off before unplugging it from the outlet.

**To prevent a possible fire, do not burn wood** or other materials in this **appliance**.

**ALWAYS disconnect** this unit from the **power supply before** performing any assembly or cleaning, or before relocating the electric fireplace.

**Always use** properly grounded, **fused** and polarized outlets.

**Always use ground fault protection** where required by electrical code.

**Avoid use** of an **extension cord** because an extension cord may overheat and cause a fire. If you have to use an extension cord, the cord should be **N.14 AWG minimum size** and rated to not less than 1875 Watts.

**NEVER** plug this appliance into an outlet that is **old, cracked**, or has any loose wires or connections. Plugging this appliance into a faulty outlet could result in **electric arcing** within the outlet that could cause the **outlet to overheat or catch fire**.

**DO NOT** run **power cord** under carpeting. **DO NOT** cover power cord with throw rugs, runners, or similar coverings. **DO NOT** route power cord under furniture or appliances. Arrange power cord **away from traffic** area, and where it will not be tripped over.

**ALWAYS** check your appliance cord and plug connections with **each use!**

- A. **MAKE SURE** the plug fits tight in the outlet! Faulty wall outlet connections or loose plugs can cause the outlet to overheat.
- B. **Appliances draw more current** than small appliances. **Overheating** may occur even if it has not occurred with the use of other appliances.
- C. During use **check frequently** to see if the **plug outlet is HOT!** If the outlet or faceplate is **HOT, discontinue use immediately** and have a qualified electrician inspect and/or replace the faulty outlets.



**WARNING: Cancer and Reproductive Harm**  
www.P65Warnings.ca.gov

919-874

## SAVE THESE INSTRUCTIONS.

**This device complies with Part 15 of the FCC Rules. Operation is subject to the following two conditions:**

- (1) This device may not cause harmful interference, and
- (2) This device must accept any interference received, including interference that may cause undesired operation.

Note: This product has been tested and found to comply with the limits for a Class B digital device, pursuant to Part 15 of the FCC Rules. These limits are designed to provide reasonable protection against harmful interference in a residential installation. This product generates, uses, and can radiate radio frequency energy and, if not installed and used in accordance with the instructions, may cause harmful interference to radio communications. However, there is no guarantee that interference will not occur in a particular installation. If this product does cause harmful interference to radio or television reception, which can be determined by turning the equipment off and on, the user is encouraged to try to correct the interference by one or more of the following measures:

- Reorient or relocate the receiving antenna.
- Increase the separation between the equipment and receiver.
- Connect the equipment into an outlet on a circuit different from that to which the receiver is connected.
- Consult the dealer or an experienced radio/TV technician for help.

Please take attention that changes or modification not expressly approved by the party responsible for compliance could void the user's authority to operate the equipment.

This equipment should be installed and operated with a minimum distance 8" (203 mm) between the radiator and your body. Refer to next page for a copy of the serial decal.

**This device complies with Industry Canada licence-exempt RSS standard(s). Operation is subject to the following two conditions:**

- (1) this device may not cause interference, and
- (2) this device must accept any interference, including interference that may cause undesired operation of the device.

Under Industry Canada regulations, this radio transmitter may only operate using an antenna of a type and maximum (or lesser) gain approved for the transmitter by Industry Canada. To reduce potential radio interference to other users, the antenna type and its gain should be so chosen that the equivalent isotropically radiated power (e.i.r.p.) is not more than that necessary for successful communication.

This appliance has been approved to the following standards:

- **ICES-003:Issue 6** - Information Technology Equipment (Including Digital Apparatus) -- Limits and Methods of Measurement
- **ANSI C63.4:2014** - American National Standard for Methods of Measurement of Radio-Noise Emissions from Low-Voltage Electrical and Electronic Equipment in the Range of 9 kHz to 40 GHz
- **ANSI C63.10:2013** - American National Standard of Procedures for Compliance Testing of Unlicensed Wireless Devices
- **47 CFR Part 15, Subpart B** - Radio Frequency Devices
- **47 CFR Part 15, Subpart C 15.231** - Radio Frequency Devices
- **C22.2 No 46-13** - Electric Air Heaters
- **UL 2021 (4th Edition)** - Fixed and Location-Dedicated Electric Room Heaters.

This device complies with Part 15 of the **FCC regulations**. Operation is subject to two conditions:

1. It must not cause harmful interference.
2. It must accept any interference, including that which may cause undesired operation.

Unauthorized modifications may void the user's authority to operate this equipment.

Notice: This device has been tested and complies with Class B digital device limits under Part 15 of the FCC rules, designed to protect against harmful interference in residential installations. It may generate, use, and emit radio frequency energy, and improper use or installation may cause interference with radio communications. Interference is not guaranteed to be prevented in all situations.

If interference occurs, it may be resolved by:

- Reorienting or relocating the receiving antenna.
- Increasing the distance between the device and receiver.
- Connecting to a different circuit than the receiver.
- Consulting with a dealer or qualified technician.

Important: The device and its antenna(s) must not be co-located with or operated alongside any other antenna or transmitter.

This is a copy of the label that accompanies each Ei29 Electric Insert. We have printed a copy of the contents here for your review.

**NOTE:** Regency® units are constantly being improved. Check the label on the unit and if there is a difference, the label on the unit is the correct one. The serial # will be 9 digits beginning with prefix of 612.

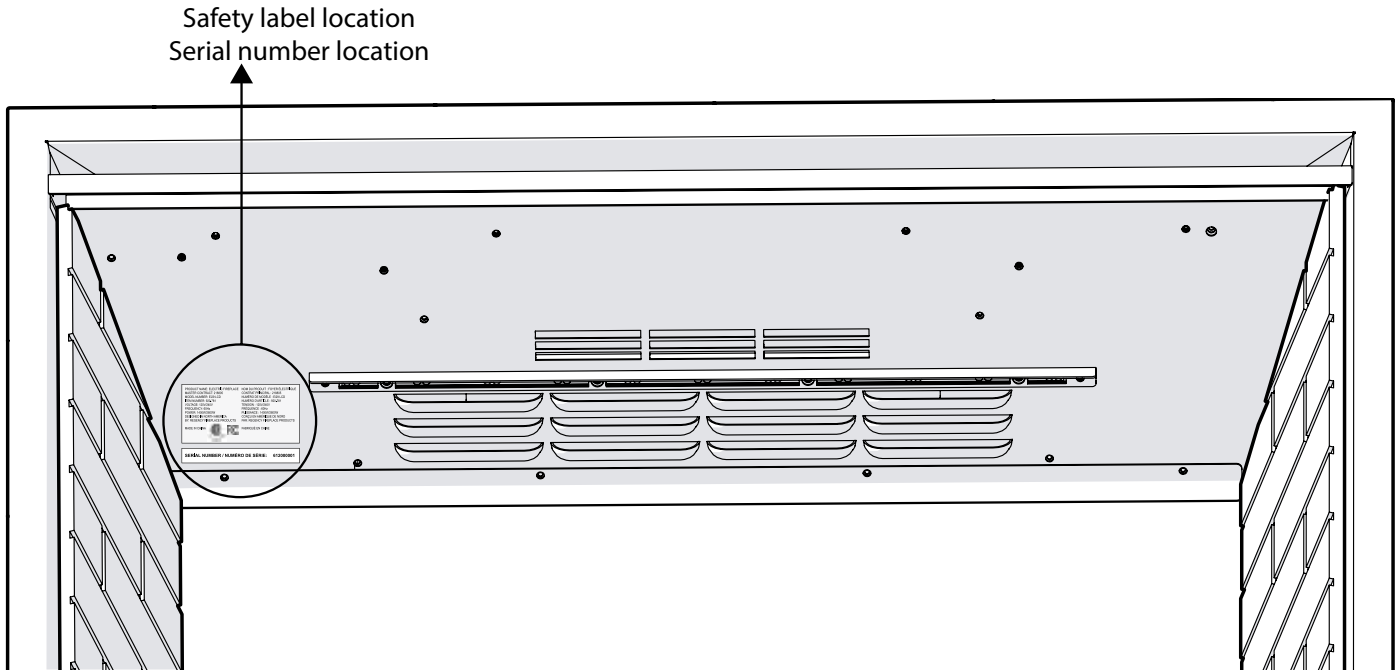

PRODUCT NAME: ELECTRIC FIREPLACE	NOM DU PRODUIT : FOYER ÉLECTRIQUE
MASTER CONTRACT: 218805	CONTRAT PRINCIPAL : 218805
MODEL NUMBER: Ei29 LCD	NUMÉRO DE MODÈLE : Ei29 LCD
ITEM NUMBER: 920-781	NUMÉRO D'ARTICLE : 920-781
VOLTAGE: 120V/240V	TENSION : 120V/240V
FREQUENCY: 60Hz	FRÉQUENCE : 60Hz
POWER: 1400W/2800W	PUISSANCE : 1400W/2800W
DESIGNED IN NORTH AMERICA	CONÇU EN AMÉRIQUE DE NORD
BY: REGENCY FIREPLACE PRODUCTS	PAR: REGENCY FIREPLACE PRODUCTS
MADE IN CHINA	FABRIQUÉ EN CHINE

Example only :

**SERIAL NUMBER / NUMÉRO DE SÉRIE: 612000001**

**Note:**The actual serial # will be located as per the safety label location shown above.

## OPERATING INSTRUCTIONS



**WARNING!** Do not operate the appliance if it is damaged or has malfunctioned. If you suspect the appliance is damaged or has malfunctioned call a qualified service engineer to inspect the appliance, and replace any part of the electrical system if necessary, before reuse.

Do not disconnect the power at the main supply while the appliance is running. Use the functions on the remote to turn the fire off and ensure the main switch has been moved to the off position before disconnecting.

## MANUAL CONTROL PANEL

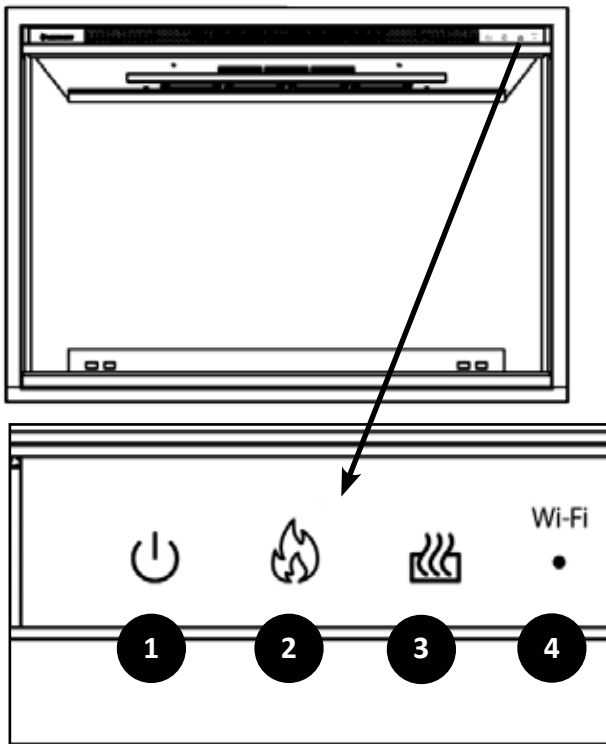

## OPERATING THE APPLIANCE

1. Power On/Off button
2. Flame On/Off button
3. Heater On/Off button
4. Wi-Fi Indicator

Press 1 to turn the appliance on/off.

Press 2 to turn flames on/off.

Press 3 to turn the heater on/off.

## REMOTE CONTROL

The remote control should be left on a flat surface in the room where the appliance is installed and away from any direct flow of hot air.









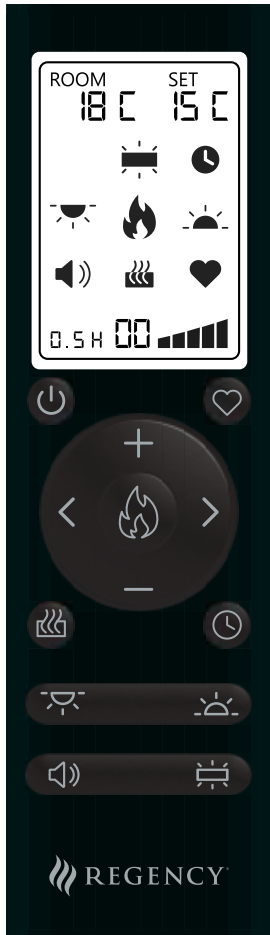



**IMPORTANT:** If operating the appliance using the remote control provided, do not touch the following buttons on the control panel. (1. Power On/Off 2. Flame On/Off button 3. Heater On/Off) These 3 buttons on the control panel are only to be used when operating the appliance in manual mode without use of the remote control.

## REMOTE CONTROL

The remote control should be left on a flat surface in the room where the appliance is installed and away from any direct flow of hot air.

### Operation Buttons

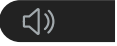

-  - Power
-  - Favourites
-  - Heater
-  - Timer
-  - \*Increase
-  - \*Decrease
-  - Color Preference (Ember Lights)
-  - Color Preference (Ember Lights)
-  - Top light
-  - Ember light
-  - Volume
-  - Mood light
-  - Flame

\*Increases or decreases heater settings, sound, top lights, ember bed, timer.

### Operation Display

 - Brightness Level / Volume

0.5 H - Timer

ROOM  
18 C - Actual Room Temperature

SET  
15 C - Temperature Setting

**NOTE: To Reset to Initial Settings, please refer to page 12 of this manual.**

**CHANGING BETWEEN FAHRENHEIT & CELSIUS**

To switch between Fahrenheit (°F) and Celsius (°C), press the heater button  for 3 seconds to trigger a long beep sound.



**OPERATING THE APPLIANCE  
- ADVANCED OPERATION**

**POWER**

**Initial Startup**

Press the main power button  to turn on the fireplace. All settings will be in their initial status:

- Flame: Option 1
- Top Light: On, Brightness Level 5
- Ember Light: On, Brightness Level 5, Orange
- Heater: Off
- Volume: On, Level 4

**Subsequent Operations**

After the initial startup, when the power is off, press the main power button once to turn on the fireplace. All settings will revert to the last operation status.

**Power On**

When the power remains on, the remote screen will continuously display icons representing the functions that are currently active.

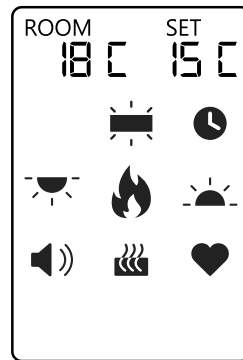



**Power Off**

To power off the device, press the main power button  once. One short beep sound will indicate that the device is powering off. The remote control display will subsequently turn off most of the icons and display only the room temperature.

**Standby Mode**

If the remote is inactive for 10 seconds or longer, the remote screen will switch to standby mode.



**HEATER**

**Turn on the Heater**

**STEP 1** - Press the heater button to turn on the heater mode. The remote LCD will display the heater icon .

**STEP 2** - Use the **+** and **-** buttons to adjust and set the preferred temperature.

**Turn off the Heater**

When the heater is on, press the heater button again to turn it off.

The heater icon will disappear from the remote LCD. All other functions will remain unchanged.



**FLAME**

**Change Flame Style**

**STEP 1** - Press the Flame button  to activate the flame adjustment mode.

**STEP 2** - Use the **<** and **>** buttons to navigate and select your preferred flame style. There are a total of 9 flame styles available.

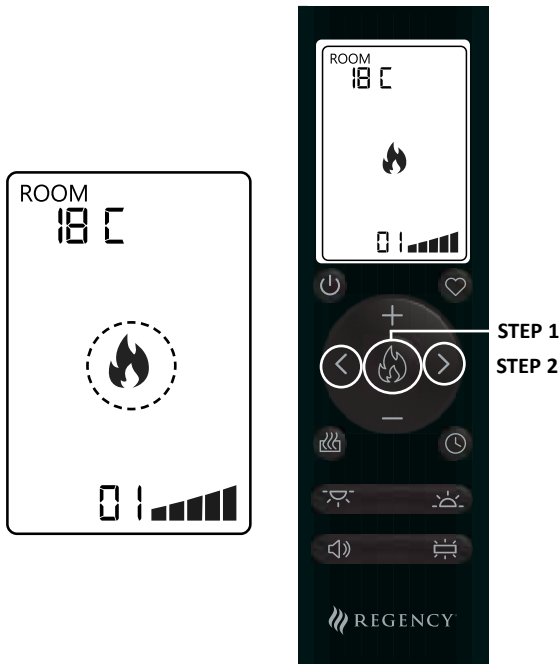

**FLAME SOUND**

**Adjust Volume:**

**STEP 1** - Press the  button to activate the sound adjustment mode.

**STEP 2** - Use the **+** and **-** buttons to navigate and select your preferred flame sound level. There are 5 sound levels available, and off mode.

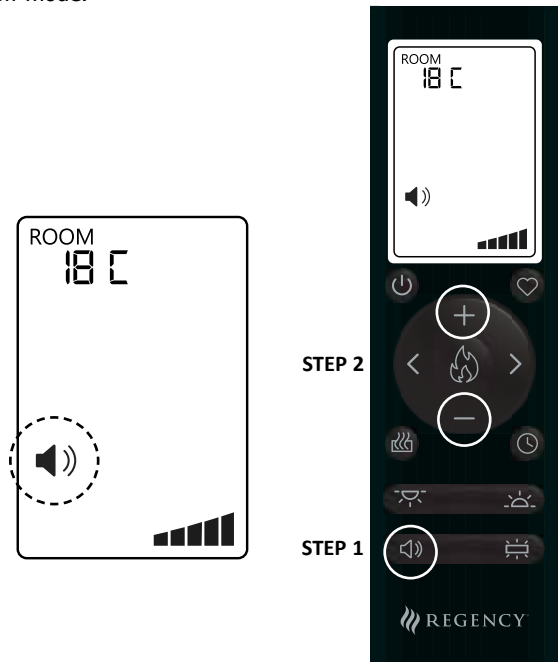

**Change Flame Brightness**

**STEP 1** - Press the  button to activate the flame adjustment mode.

**STEP 2** - Use the **+** and **-** buttons to navigate and select your preferred flame brightness. There are 5 brightness levels available, and off mode.

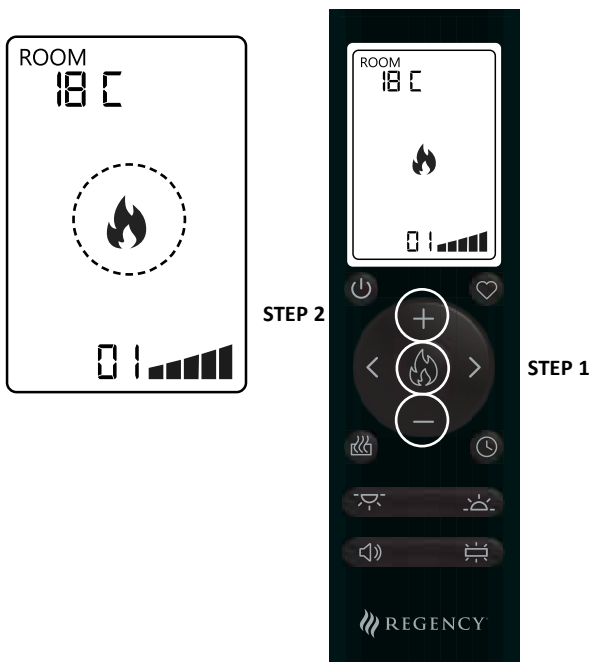

**TOP LIGHT**

**Change Top Light Brightness**

**STEP 1** - Press the  button to activate the top light adjustment mode.

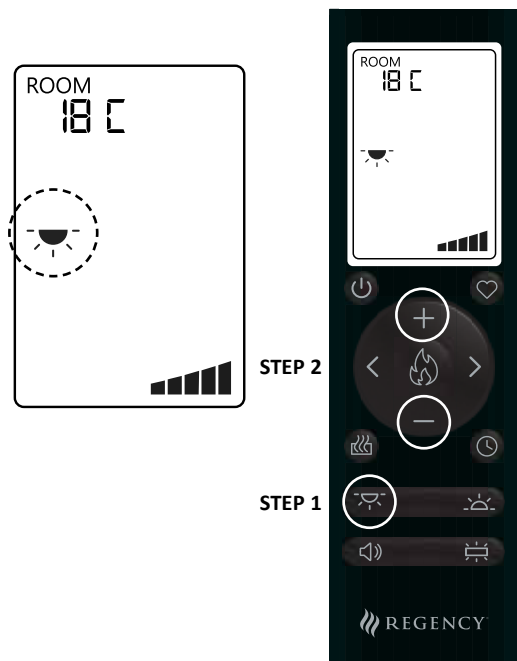

**STEP 2** - Use the **+** and **-** buttons to navigate and select your preferred brightness level. There are 5 brightness levels available, and off mode.



**EMBER LIGHTS**



**Change Ember Light Colour**

**STEP 1** - Press the  button to activate the ember light adjustment mode.

**STEP 2** - Use the  and  buttons to navigate and select your preferred color option. There are 14 color options in total.

**Change Ember Light Brightness**

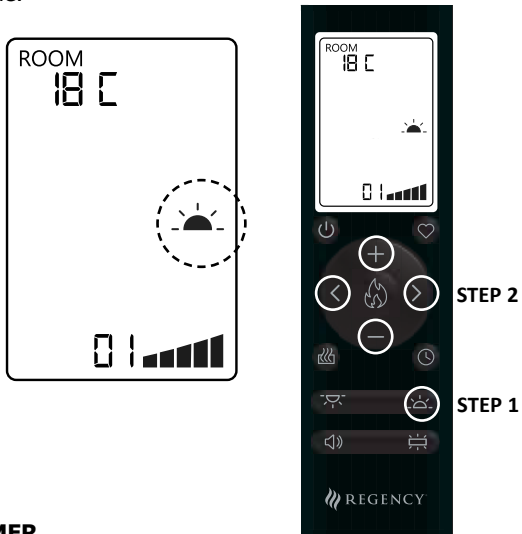

Press the  button to activate the ember light adjustment mode.

Use the  and  buttons to navigate and select your preferred brightness level. There are 5 brightness levels available, and off mode.



**TIMER**

**STEP 1** - Press the  button to activate the timer.

**STEP 2** - Use the  and  buttons to set the timer to one of the following options: 0.5h, 1h, 2h, 3h, 4h, 5h, 6h, 7h, 8h, 9h, 10h or Off.

The remote screen will automatically return to the operating status display after 10 seconds of inactivity.

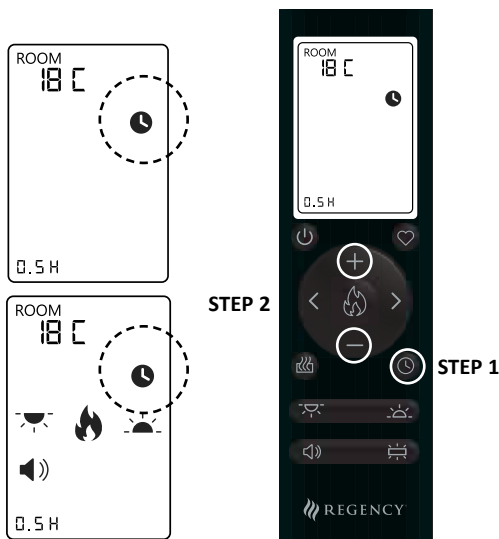

**FAVOURITES**

**Change Favourite Mode**

**STEP 1** - Press the  button to activate the favourites mode. Press the favorites button to switch between Favorite Mode options: 1, 2, 3, or Off. The favorite sign and its option number will be displayed.

In Off mode, all settings will revert to the last operation status.

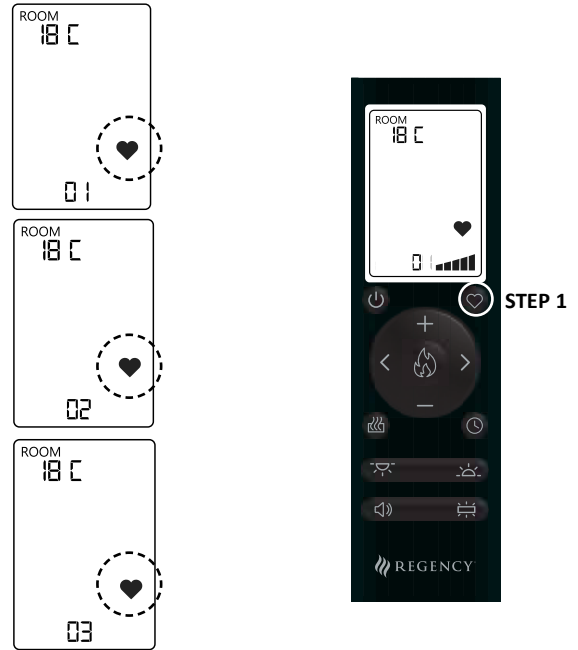

**Overwriting Favorite Mode 1,2 and 3:**

**STEP 1** - Select the favorite mode 1, 2, or 3 that you wish to overwrite. With this mode selected, make the desired adjustments using the flame option, flame brightness, flame burning sound level, ceiling light brightness, and ember bed and log light color and brightness according to your preference.

**STEP 2** - Long press the Favorite Mode  button for 3 seconds. A long beep will indicate that your preference has been saved and will overwrite the previous configuration in the chosen Favorite option.

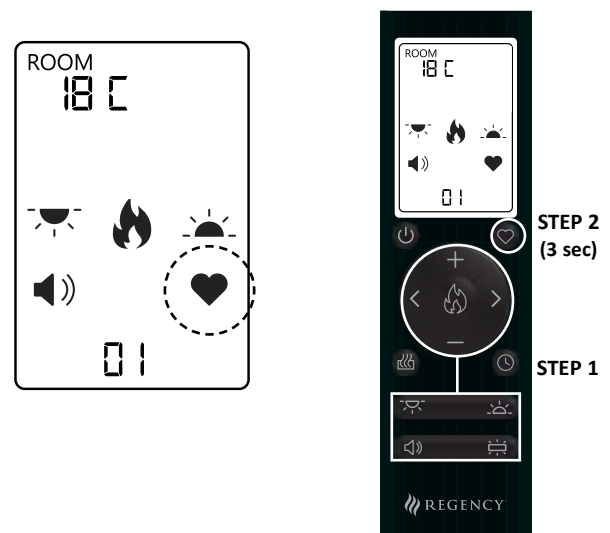

**RESET**

**Reset to Initial Settings:**

**STEP 1** - Press and hold for 3 seconds the  button to reset the unit.

To reset all settings to their initial mode:

Flame: Option 1

Top Light: On, Brightness Level 5

Ember Light: On, Brightness Level 5, Orange

Heater: Off

Volume: On, Level 4

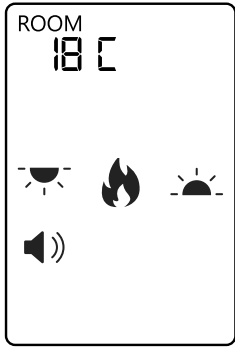

STEP 1  
(3 sec)

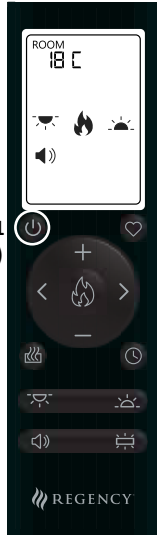



**MOOD LIGHT (OPTION)**

**Mood Light Adjustment Mode:**

short press to turn on and off the mood light



**STEP 1** - Press and hold for 3 seconds to activate the mood light adjustment mode.

**Color Option:**

**STEP 2** - Use the  and  buttons to navigate and select your preferred color option.

There are 14 color options in total include light off.

**Change Brightness:**

Use the  and  buttons to navigate and select your preferred brightness level.

There are 5 brightness levels available, and off mode.

**NOTE: Mood Light is Not included. Only when mood light is installed this function will be available. Must be purchased separately.**

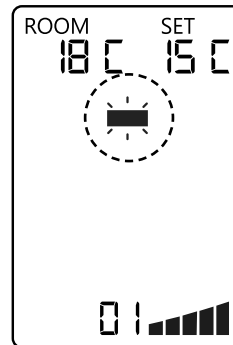

STEP 2

STEP 1

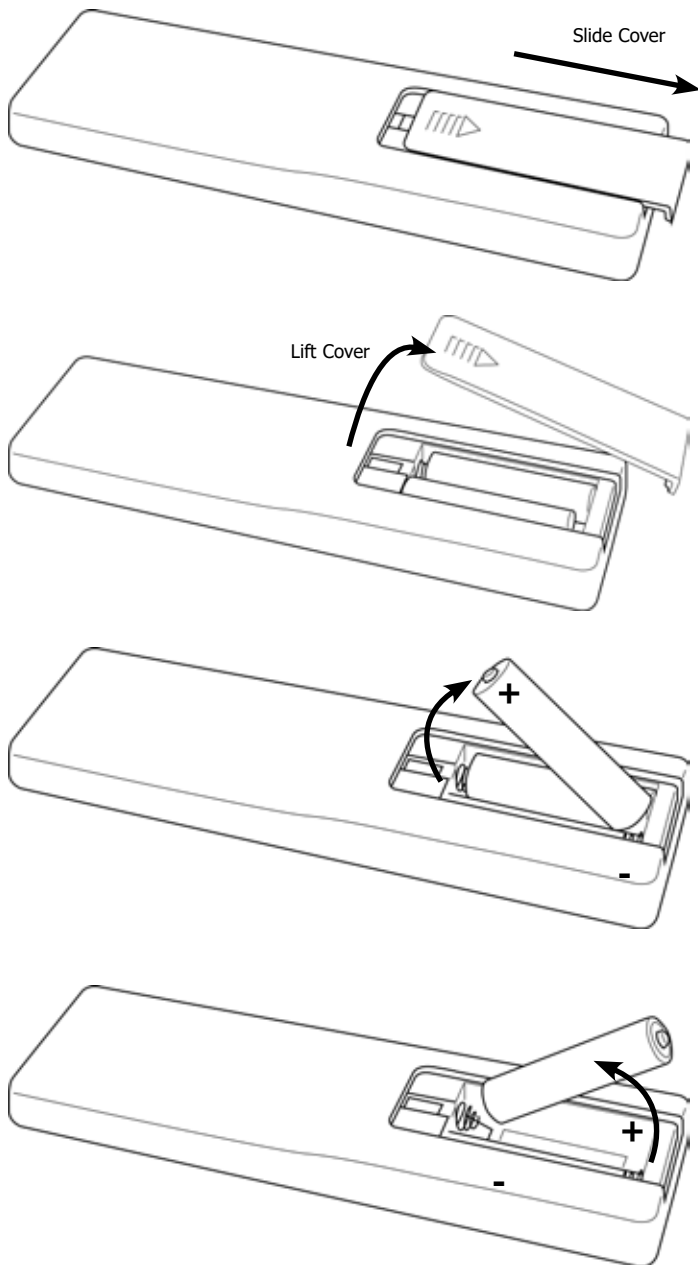

Ensure that the handset batteries are new and inserted correctly.

The Remote requires two 1.5V alkaline AAA batteries.

Ensure the correct polarity.  
Do not short circuit the terminals.

Do not attempt to recharge non-rechargeable batteries.

Remove rechargeable batteries before charging.

Do not mix old and new batteries.

Remove batteries if the appliance is not used for long periods.

**Changing the batteries will not affect the Timer settings.**

## MAINTENANCE

**ENSURE THE APPLIANCE IS TURNED OFF BEFORE CLEANING.**

### GLASS CLEANING

Wipe the glass viewing panel with a damp cloth and buff with a lint free duster.

**Caution: Do not use abrasive cleaners on the glass panel. Do not spray liquids directly onto any surface of the unit.**

**CLEANING AIR INLETS**

Clean the air inlet and outlet grilles regularly with a soft cloth or the nozzle of a vacuum cleaner.

**Dust build-up can inhibit efficient performance of the fan and lead to the safety cut-out operating.**

Keep the area around the appliance clean and free of fluff, dust or pet hair.

In particular, build-up of dust etc. can occur around the heater area. Take particular care to keep this area free from such particles on a regular basis to prevent build-up.

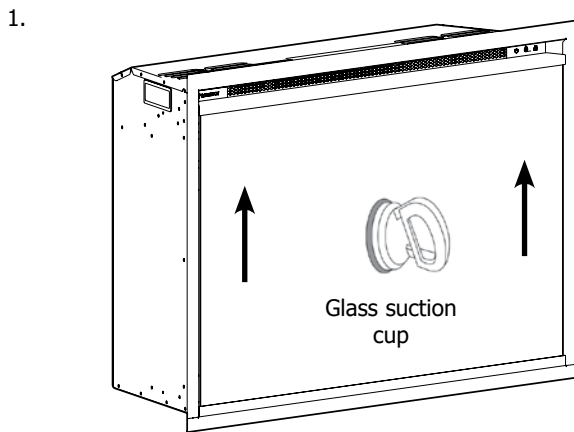
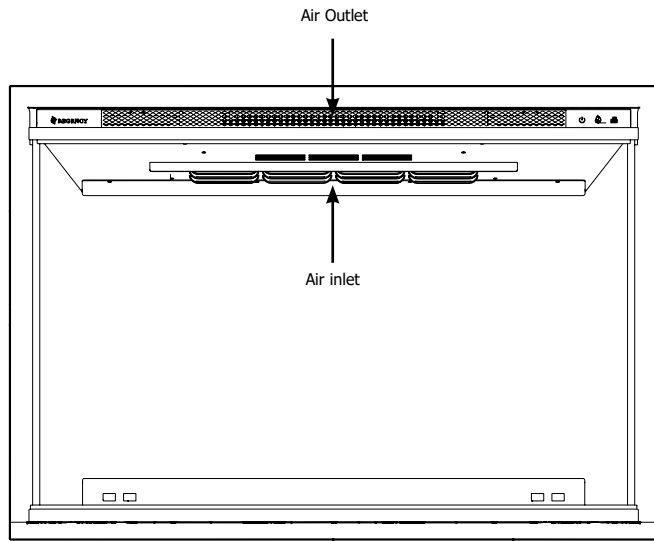

2.

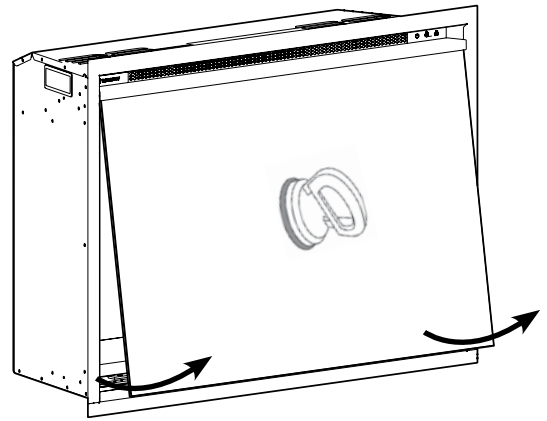

3.

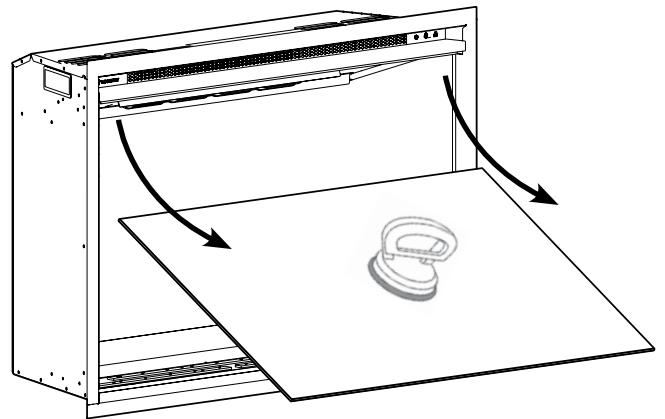

4. To reinstall glass reverse steps 1-2. Ensure the suction cup is safely stored away for future use.

## INSTALLATION

### GENERAL

#### TOOLS REQUIRED

A Screwdriver, Level, and Drill will be needed.

#### UNPACKING THE FIREPLACE

**WARNING! DO NOT use this appliance if any part has been exposed to water.**

Immediately call a qualified service technician to inspect and to replace any part of the electrical system if necessary.

Open the packaging carefully and remove the polystyrene. Remove and discard the plastic bag. Keep plastic wrapping away from children. Be responsible when handling the packing materials.

Check all parts and accessories are removed before disposing of any packaging. If necessary keep the original packaging for future transport and/or storage. Test the appliance before installation.

### FITTING THE APPLIANCE

#### LOCATING THE Ei29 LCD

Your new Ei29 LCD may be installed virtually anywhere in your home. However, when choosing a location ensure that the general instructions are followed.

For best results, install out of direct sunlight.

**The heater should ideally be fitted into/onto an internal flat wall constructed from either wood framing and drywall/brick, etc. The fixings provided are for use on masonry fireplace ONLY. Please ensure that suitable fixings are used when securing to any hollow or purpose built cavity. This may also be installed into a masonry fireplace as long as it meets the requirements as per below.**

**NOTE: This appliance is not suitable for fitting to a Cavity Wall, backing on to an outside wall, an open chimney or any opening that may be subject to damp and draft, unless adequate precautions are taken to avoid the appliance coming into contact with moisture or excessive drafts.**

**Into Framed construction:** For exterior/outside walls, insulate the enclosure to the same degree as the rest of the house, apply vapor barrier and drywall, as per local installation codes. Do not insulate the appliance itself.

**Into masonry chimneys:** The flue damper must be fully blocked if safe to do so for installation of the unit. Ensure the fireplace and chimney are clean and in good working order, and that all chimney clean-outs are tight-fitting and not permitting air into the chimney. Install a sealed vent cap and metal flashing at the top of the masonry chimney to prevent water leaks and air movement within the cavity. Do not insulate the appliance itself.

**Make sure there are no pipes or cables behind the area to be drilled or cut.**

Always ensure the appliance is adequately supported and sits on a firm structure when mounting above floor level.

### WIRING KITS

This appliance is supplied with a 3 prong plug with a 93.3" (2.37m) lead.

**Note: Must be plugged into a 3 prong receptacle which is exposed and accessible. Do not under any circumstances, cut the ground on the 3 prong plug.**

This appliance is for use on 120 Volts only with the supplied power cord. The cord has a plug as show in (A). An adapter as shown in (C) is available for connecting three-blade grounding type plugs to two slot receptacles. The green grounding lug extending from the adapter must be connected to a permanent ground such as a properly grounded outlet box. The adapter should not be used if a three-slot grounded receptacle is available.

The appliance should ideally be located close to a suitable receptacle to enable connection. An extension could be run from an existing socket outlet but this must be carried out by a suitably qualified electrical engineer. The electrical socket must be easily accessible to allow disconnection when the appliance is fitted. If the power cord is damaged, it must be repaired by the authorised service centre or professional person.

Ensure that curtains and furniture are not positioned close to the chosen position, as this would create a potential fire hazard or block the heater outlet ducts.

**WARNING! KEEP ALL COMBUSTIBLE MATERIALS AT LEAST 1M (3.3 FEET) FROM THE FRONT OF THE ELECTRIC FIREPLACE.**

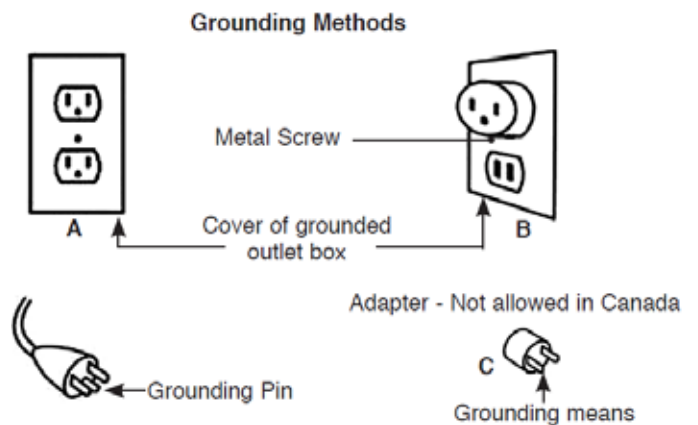

To disconnect the appliance, turn the controls to off, then remove plug from outlet.





**This appliance must be connected and grounded in accordance with local codes, if hard wired. In the absence of local codes, the use the current CSA C22.1 CANADIAN ELECTRICAL CODE in CANADA or the current ANSI/NFPA 70 NATIONAL ELECTRICAL CODE in the UNITED STATES.**

#### HARDWIRING

This appliance can also be hardwired. See HARDWIRED INSTALLATION within this manual for details.

**INCLUDED ITEMS**

**Ei29LCD:**

<p>- 1 Remote control</p>	
<p>- 2 AAA Batteries</p>	
<p>- 1 Suction Cup for glass removal</p>	
<p>- 1 Ember bed (pre-installed with the unit)</p>	
<p>- 1 Instruction manual</p>	



## SERVICING REQUIREMENTS



**DURING SERVICING OF THIS APPLIANCE IT MAY BE NECESSARY TO CUT CABLE TIES IN ORDER TO ACCESS AND REMOVE SOME OF THE PARTS. THESE MUST BE REPLACED WHEN REASSEMBLING THE APPLIANCE.**

**THIS APPLIANCE MUST ONLY BE SERVICED BY A SUITABLY QUALIFIED PERSON. BEFORE UNDERTAKING ANY WORK ON THE APPLIANCE: SWITCH OFF THE APPLIANCE AND ISOLATE THE POWER SUPPLY ENSURING THERE IS NO POWER TO THE APPLIANCE.**

Wait for at least 10 minutes until the appliance has cooled down.

### **Remote Handset Battery Replacement**

Replace with 2 AAA batteries. Make sure the batteries are installed correctly in the remote control.

### **Resetting the Thermal Cutout Switch**

The appliance is fitted with an Electronic Safety Control (E.S.). This is a safety device which switches off the fire if the appliance overheats for any reason e.g. when covered.

If the heater stops operating while the flame effect continues normally, this indicates that the E.S. Control is in operation.

The E.S. Control can only be re-set after the appliance has cooled down.

To re-set the E.S:

Switch off the appliance (Manual On/Off switch) and leave for approximately 120 minutes.

Remove any obstruction to the fan heater outlet or other internal parts.

Switch on appliance and the E.S. Control will re-set. Ensure that the appliance is functioning correctly. If the E.S. Control operates again, the appliance should be checked by a competent Electrician.

TECHNICAL SPECIFICATION

UNIT DIMENSIONS

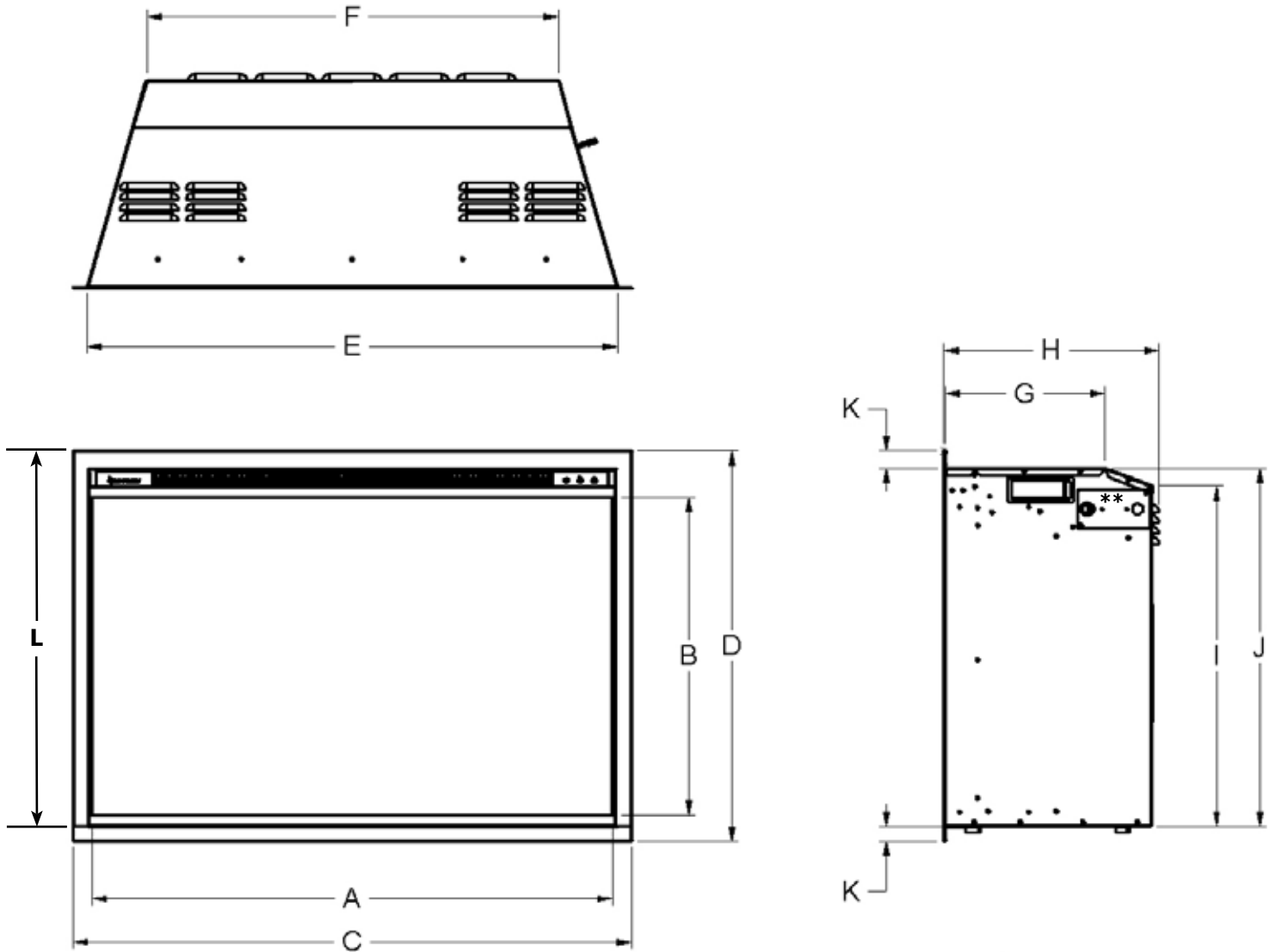

DIMENSIONS	A	B	C	D*	E	F
Ei29 LCD	736 mm (29 in)	450 mm (17-3/4 in)	789 mm (31-1/16 in)	554 mm (21-13/16 in)	750 mm (29-1/2 in)	582 mm (22-15/16 in)
	G	H	I	J	K	L
	226mm (8-15/16 in)	304 mm (12 in)	482 mm (19 in)	507 mm (20 in)	21 mm (13/16 in)	533 mm (21 in)

\* With 4-sided finishing trim installed

\*\* Location of Electrical located on right hand side of appliance.

For use with 120 VAC 60 Hz 3 prong plug (supplied) or 120 VAC 60 Hz hardwire option.

240 VAC power supply with hardware installation only.

Note: The wiring from the appliance to the breaker must be supplied by a qualified electrician. This is not supplied with the appliance.

For use with 120V 60Hz electricity supply.

240V supply with hardwire installation only.

## FACEPLATE DIMENSIONS

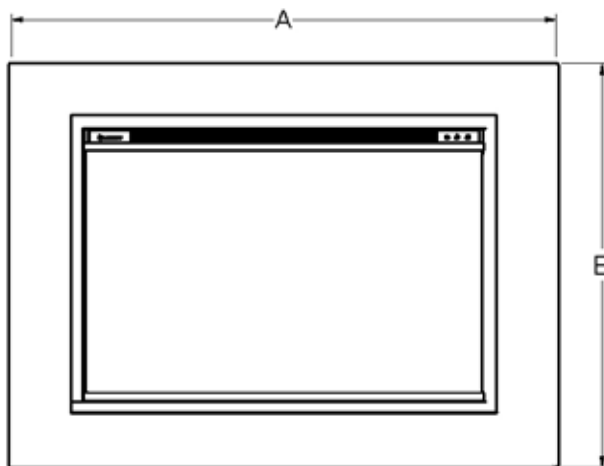
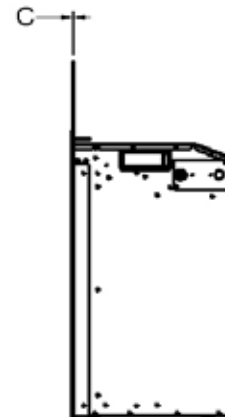
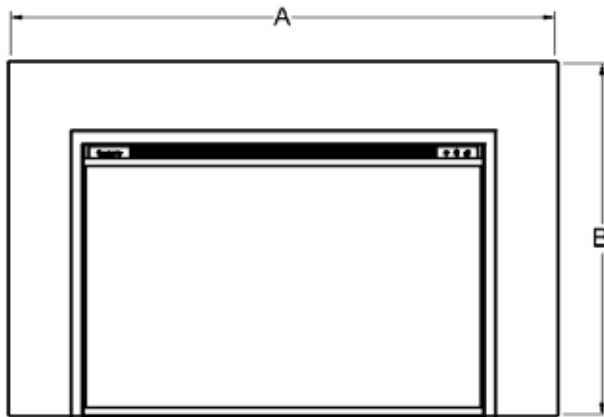

Faceplate	Dimensions			
	Width (A)	Height (B)	Depth (C)	Bottom Height (D)
3 Sided Finishing Trim*	31-1/16" (789mm)	21" (533mm)	1/8" (3mm)	-
4 Sided Finishing Trim**	31-1/16" (789mm)	21-13/16" (554mm)	1/8" (3mm)	13/16" (21mm)
3 Sided Flush Faceplate	40-3/16" (1021mm)	26" (661mm)	1/16" (2mm)	-
3 Sided Flush Faceplate w/ Premium Surround	40-13/16" (1037mm)	26-3/8" (670mm)	1-11/16" (43mm)	-
3 Sided Flush Faceplate w/ Traditional Surround	45-3/4" (1162mm)	28-3/4" (731mm)	2-1/4" (57mm)	-
4 Sided Flush Faceplate	40-3/16" (1021mm)	29-1/2" (750mm)	1/16" (2mm)	4-3/4" (121mm)
3 Sided Oversized Backing Plate	47-1/2" (1207mm)	31-1/2" (800mm)	1/16" (2mm)	-
3 Sided Custom Faceplate	33-1/16" - 56-7/8" (840mm - 1445mm)	21-7/8" - 44-7/8" (556mm - 1140mm)	1/16" (2mm)	-
4 Sided Custom Faceplate	33-1/16" - 69" (840mm - 1753mm)	23-13/16" - 45" (605mm - 1143mm)	1/16" (2mm)	1-7/8" min (48mm)

\* Bottom trim from 4 sided finishing trim is removed to create a 3 sided.

\*\* Included with appliance

## MINIMUM FIREPLACE OPENING SIZES WITH VARYING FACEPLATE OPTIONS

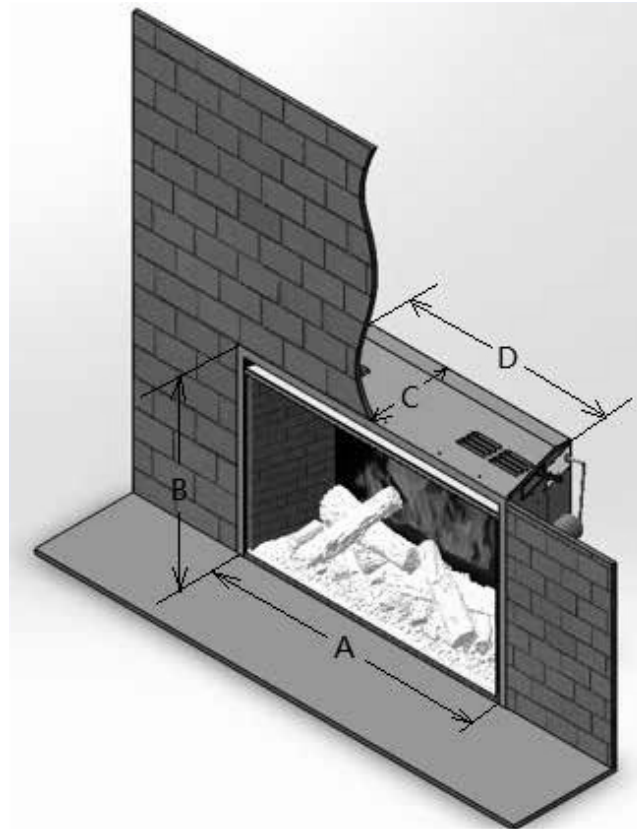

Faceplate	Dimensions			
	Min Install Width (A)	Min Install Height (B)	Min Install Depth (C)	Min Rear Width (D)
3 Sided Finishing Trim*	29-11/16" (754 mm)	20-3/8" (518 mm)	11-7/8" (302 mm)	23-3/8" (594 mm)
3 Sided Finishing Trim w/ Backing Plate	30-5/8" (778mm)	20-3/4" (527mm)	11-13/16" (300mm)	23-5/16" (592mm)
4 Sided Finishing Trim**	29-5/8" (752mm)	20-5/16" (516mm)	11-13/16" (300mm)	23-5/16" (592mm)
3 Sided Flush Faceplate	29-13/16" (757mm)	20-9/16" (522mm)	11-13/16" (300mm)	23-5/16" (592mm)
3 Sided Flush Faceplate w/ Backing Plate	30-5/8" (778mm)	20-3/4" (527mm)	11-3/4" (298mm)	23-5/16" (592mm)
3 Sided Flush Faceplate w/ Premium Surround	29" (737mm)	20-3/16" (513mm)	10-7/16" (265mm)	23-5/16" (592mm)
3 Sided Flush Faceplate w/ Premium Surround and Backing Plate	30-5/8" (778mm)	20-3/4" (527mm)	10-3/8" (264mm)	23-5/16" (592mm)
3 Sided Flush Faceplate w/ Traditional Surround	28-7/16" (722mm)	20-1/8" (511mm)	9-3/4" (248mm)	23-5/16" (592mm)
3 Sided Flush Faceplate w/ Traditional Surround and Backing Plate	30-5/8" (778mm)	20-3/4" (527mm)	9-11/16" (246mm)	23-5/16" (592mm)
4 Sided Flush Faceplate	29-13/16" (757mm)	20-13/16" (529mm)	11-13/16" (300mm)	23-5/16" (592mm)
3 Sided Custom Faceplate	29-13/16" (757mm)	20-9/16" (522mm)	11-13/16" (300mm)	23-5/16" (592mm)
4 Sided Custom Faceplate	29-13/16" (757mm)	20-13/16" (529mm)	11-13/16" (300mm)	23-5/16" (592mm)

\* Bottom trim from 4 sided finishing trim is removed to create a 3 sided.

\*\* Included with appliance

## ELECTRICITY SUPPLY

A 120V 12.5A 60Hz supply is required.

Rated power consumption:

Ei29LCD: 1400 Watts

Optional (Hardwire only) 240V 2 phase 15A 60Hz supply can be utilized.

Rated power consumption:

Ei29LCD: 2800 Watts

**THIS APPLIANCE MUST BE GROUNDED.**

**IMPORTANT: A 15 AMP, 60Hz circuit is required for 120 VAC installation. Additional appliances on the same circuit may exceed the current rating of that circuit. A dedicated circuit is not required, but is preferred to prevent circuit breaker trips or fuse failure. Optional 240 VAC 2 phase may only be hardwired. FAILURE TO ADEQUITLY POWER APPLIANCE AT REQUIRED VOLTAGE AND AMPERAGE WILL VOID YOUR WARRANTY.**

A 3 prong plug with 93.3" (2.37m) power lead and a separate hard wiring kit are supplied.

2 x Remote control handset battery (AAA).

Note: The wiring from the appliance to the breaker must be supplied by a qualified electrician. This is not supplied with the appliance.

## INSTALLATION INSTRUCTIONS

### MASONRY FIREPLACE

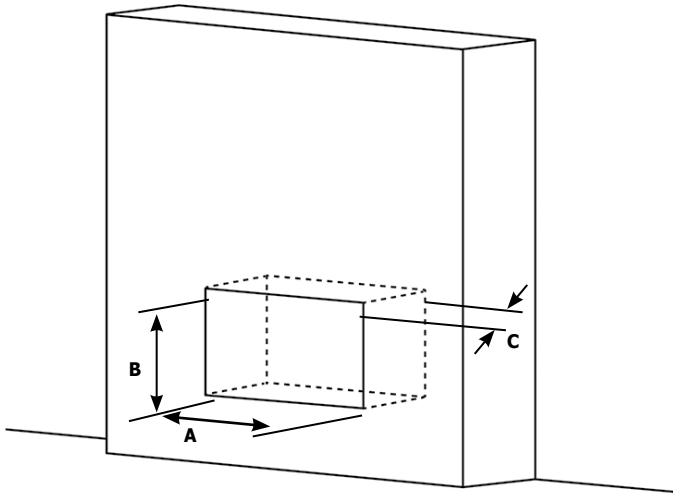

### WOOD FRAMING

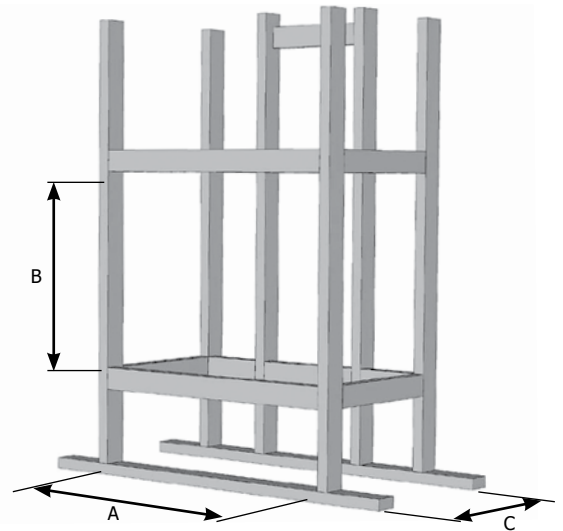

**NOTE: ALSO SEE MINIMUM FIREPLACE OPENING SIZES WITH VARYING FACEPLATE OPTIONS AS THE OPENING SIZE (A,B,C) WILL VARY DEPENDING ON FACEPLATE USED. SEE PAGE 20 FOR DETAILS.**

#### MINIMUM OPENING SIZE

	A	B	C
Dimensions	755 mm (29-3/4 in)	523 mm (20-9/16 in)	320 mm (12-5/8 in)

### Electrical Receptacle in a Masonry Fireplace/Wood Framing

The electrical receptacle (if permitted) can be placed on the left or right side of the unit within the masonry/wood framing enclosure, respecting the following conditions:

1. Distance from the receptacle face to the insert minimum 3" (76 mm).
2. Height from the top of the receptacle to the floor of the fireplace: maximum 3.5" (89 mm).
3. The receptacle box and receptacle cover must be made of metal.
4. Where the 120-volt power cord exits toward the receptacle, it must not come into contact with the back or sides of the insert. When installed, this appliance must be grounded in accordance with local codes, or in their absence, the National Electrical Code ANSI/NFPA 70, or the Canadian Electrical code CSA C22.1.

**IMPORTANT: Check with your local inspector before starting this installation, as some jurisdictions may not allow placement of this receptacle within a masonry chimney/Fireplace/wood framing.**

**Note: Ensure that the appliance is sitting on a solid continuous surface which is the full width and depth of appliance and is level.**

### Finishing Materials (Wood Framing)

Combustible or non-combustible finishing materials may be used to finish up to the fireplace.

**DO NOT PACK THE VOID AROUND OR ABOVE THE APPLIANCE WITH INSULATION OR MINERAL WOOL.**

**NOTE: In order to avoid the possibility of exposed insulation or vapour barrier coming into contact with the appliance body, it is recommended that the walls of the appliance enclosure be "finished" off with drywall/sheetrock as you would finish any other outside wall of a home. This will ensure that clearance to combustibles is maintained within the cavity.**

Once the opening has been prepared and the power has been routed to the right side (if hardwiring) of the appliance, follow steps below.

- A. Remove the glass front (See glass front removal)
- B. If leveling legs are required this should be installed with the bolts provided.
- C. If optional flush/backing faceplate is being installed this should be done prior to sliding unit into position
- D. If hardwiring, the electrical connections must also be made prior to placing the appliance into opening.
- E. Level the appliance and slide insert into its final position
- F. Install the log set
- G Reinstall the glass front.
- H. Plug 3 prong plug into a suitable receptacle or if hardwired, turn breaker on.

## MANTEL CLEARANCES

Combustible mantel clearances from top of finishing trim are shown in the diagram below.

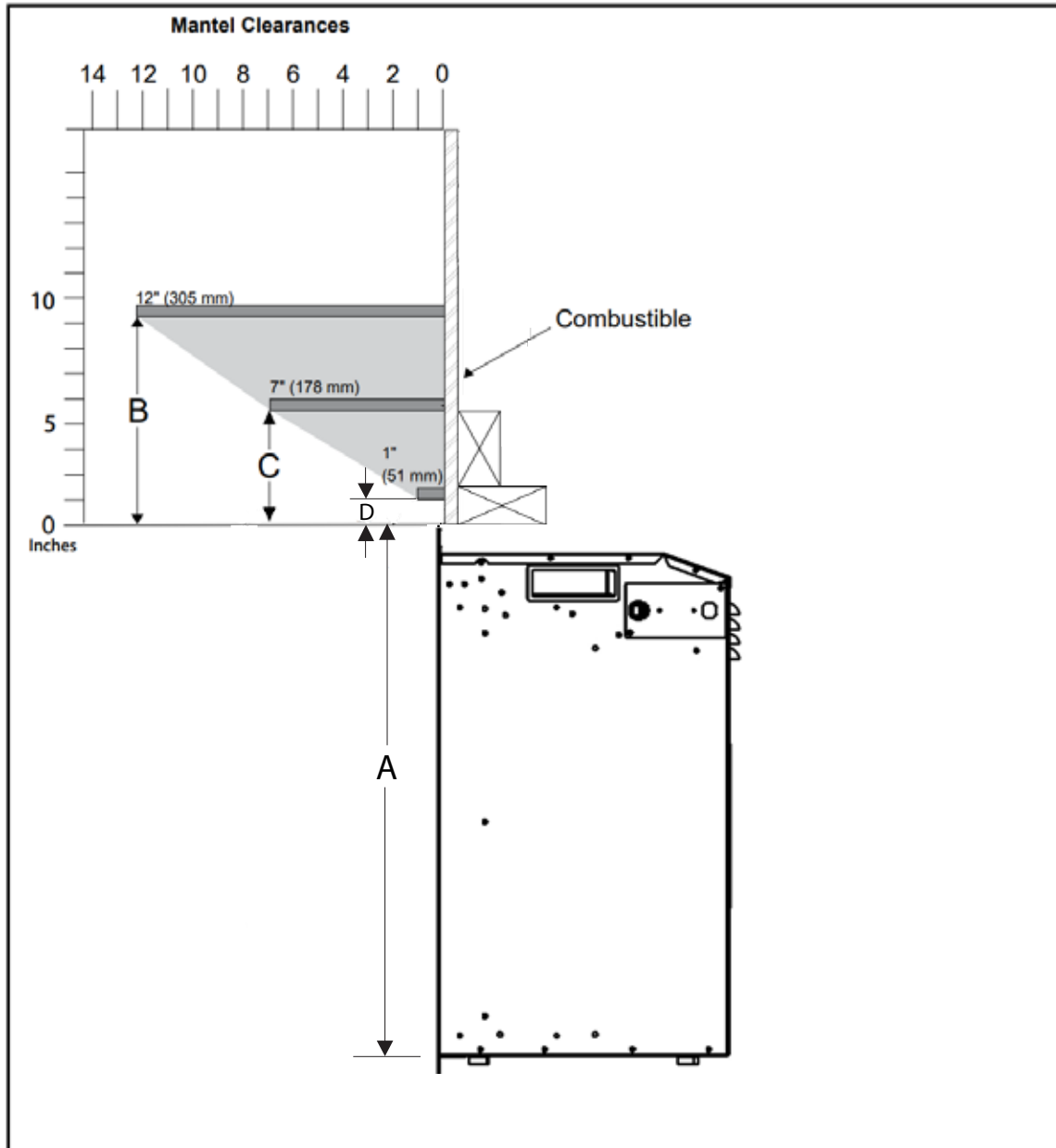

	A	B	C	D
Dimensions	533 mm (21 in)	235 mm (9-1/4 in)	140 mm (5-1/2 in)	25 mm (1 in)

**Note:** Ensure the paint that is used on the mantel and the facing is "heat resistant" or the paint may discolour. Measurement (A) is shown with 3 sided finishing trim.

If using any of the optional flush faceplate's/backing plates/custom backing plates which have various heights depending on faceplate chosen, ensure mantel begins above the actual faceplate using the chart above as the mantel cannot overlap the faceplate Also see faceplate/backing plate sizes in this manual.

## LEVELING LEGS

**NOTE:** The leveling of the appliance must be done prior to sliding appliance into final position.

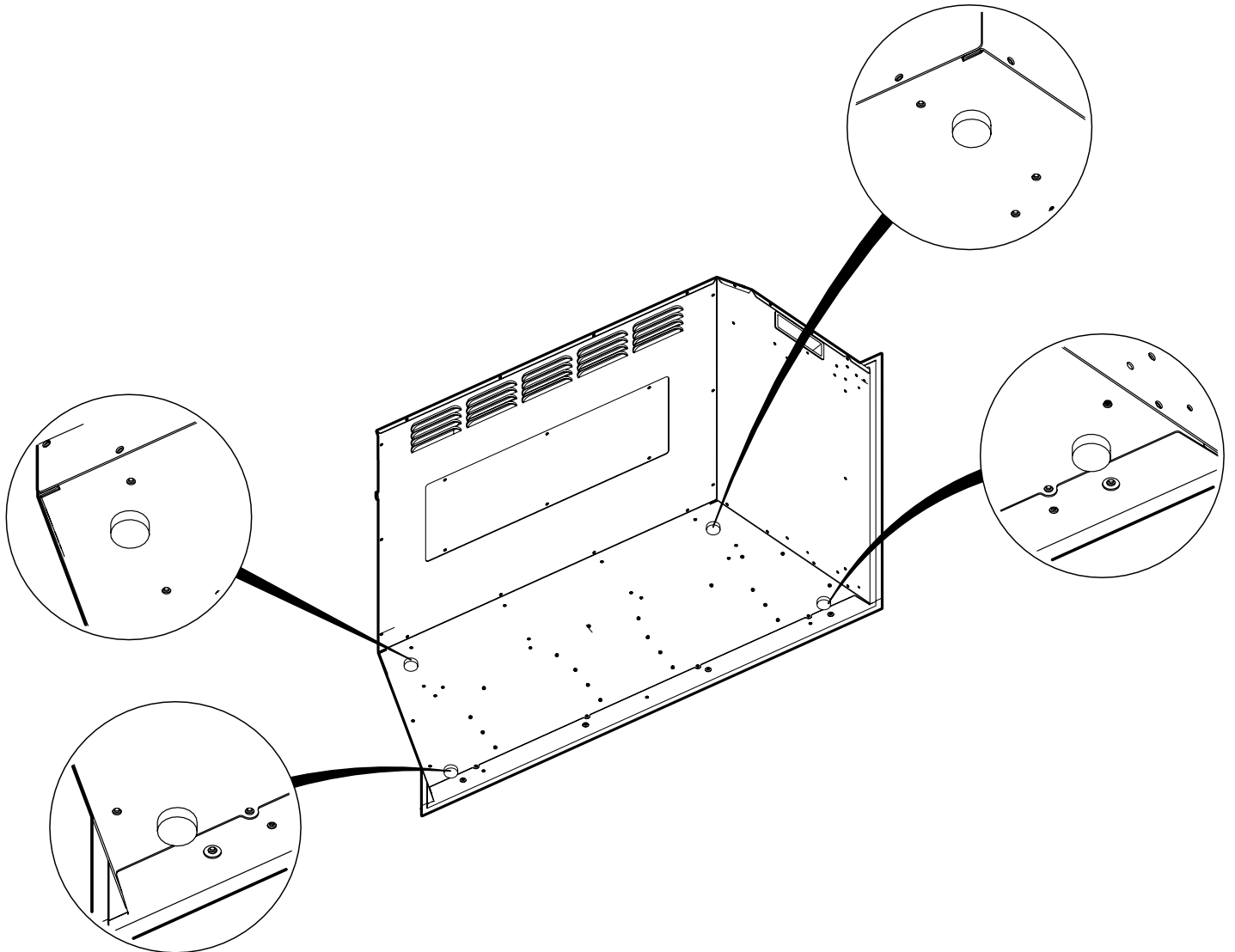

The leveling legs which are supplied must be installed from below the unit as shown. Rest appliance on its back and secure 4 legs as shown above. Once it is in position, adjust the legs to ensure the appliance is level and won't rock.



## REMOVAL INSTRUCTIONS

### REMOVING GLASS FRONT

1. Carefully use the glass suction cup provided to remove the glass. First, lift the glass to clear the bottom edge.

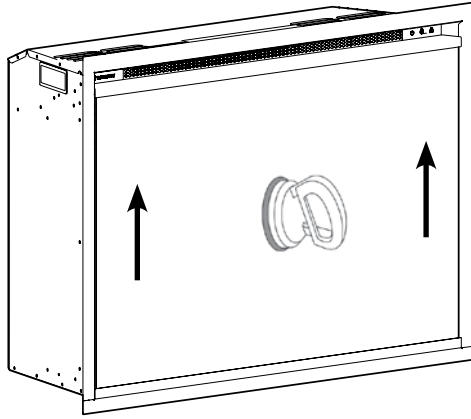

2. Swing the bottom edge of the glass out.

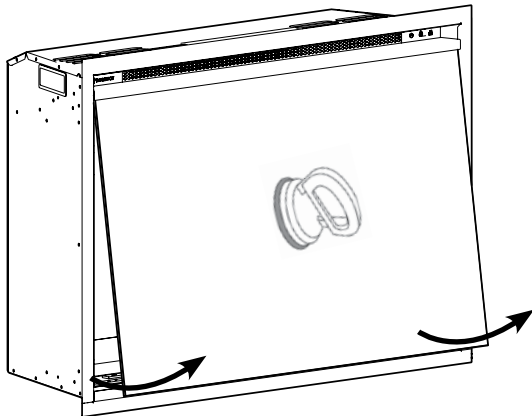

3. Swing the top edge of the glass down and out

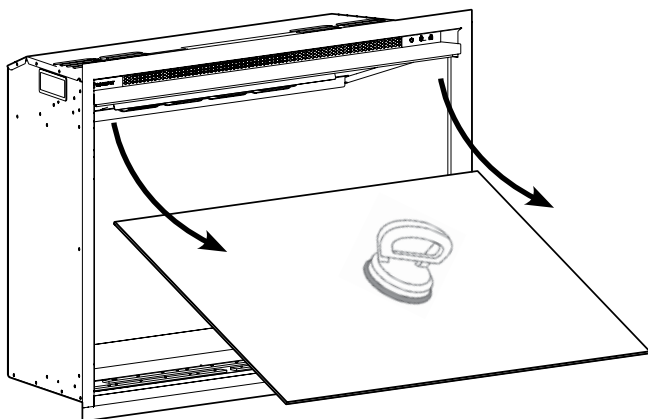

4. To reinstall glass, reverse steps 1-2. Ensure the suction cup is safely stored away for future use.

**Note:** The glass should only be installed once all the optional accessories and media have been installed and appliance is in final position.

**Note:** When stripping back the wires ends from the BX cable, they should be stripped back appropriately 1/2" (13 mm) for both 120VAC or 240VAC applications.

**FOR 120VAC APPLICATIONS:**

The following instructions must be followed to install a 3-wire Romex cable to the terminal.

1. Connect the voltage line (black) to the L1 terminal.
2. Connect the neutral wire (white) to the N terminal.
3. Connect the ground line (green) to the ground terminal.
4. Make sure that no wire is connected to the L2 terminal.

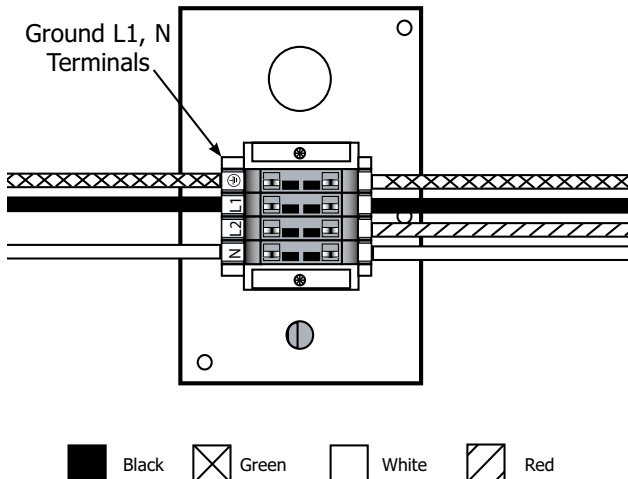

**FOR 240VAC APPLICATIONS:**

The following instructions must be followed to install a 4-wire Romex cable to the terminal.

1. Connect the voltage line 1 (black) to the L1 terminal.
2. Connect the voltage line 2 (red) to the L2 terminal.
3. Connect the neutral line (white) to the N terminal.
4. Connect the ground line (green) to the ground terminal.

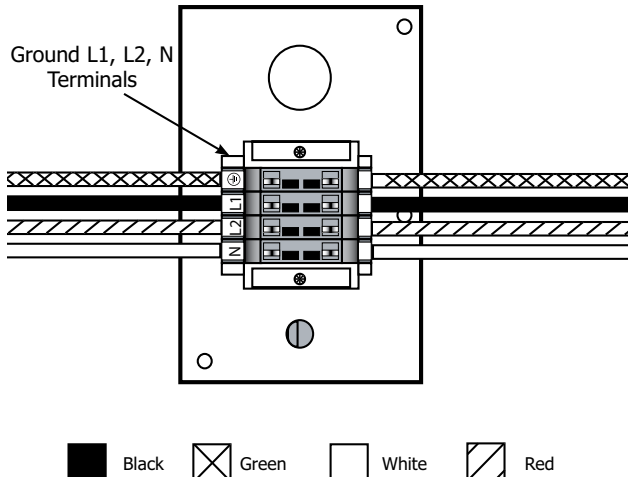

**FOR ALL APPLICATIONS:**

**IMPORTANT**

Ensure all connections are right and there are no exposed wires. Tighten Romex strain relief and reattach junction box cover plate.

Inspect that the correct voltage is selected on the selector switch located inside the unit. Failure to do so could damage the product.

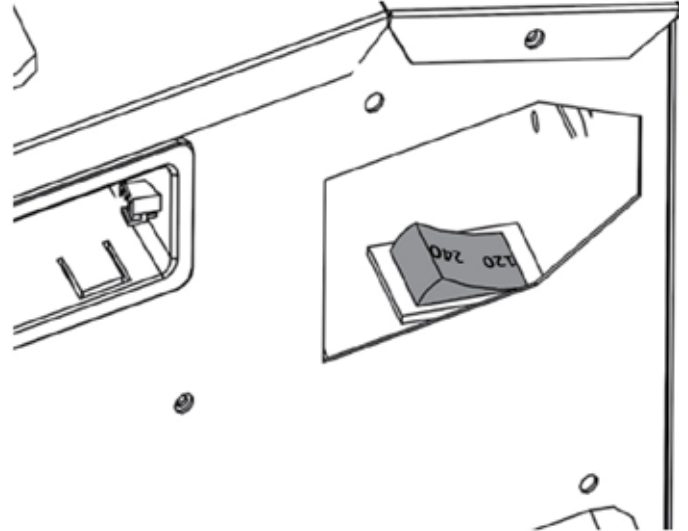

Replace terminal block cover plate and retaining screws.

**COMPLETING THE INSTALLATION**

This appliance comes standard with a 4 sided finishing trim. The appliance can be installed with the 4 sided finishing trim only or as a 3 sided by removing the bottom trim. See below.

Uninstall the bottom trim by removing these 3 screws. See below. The bottom trim is not required and may be recycled along with the 3 screws.



Also offered are the flush faceplate, backing plate & custom backing plate which can be used to cover openings which are larger than the 3/4 sided finishing trim or to enhance appearance.

### 3-Sided Faceplate Installation

These instructions are for use with the following products:

PART #	Description
281-912	Faceplate 3-Sided Flush
281-937	Faceplate Custom 3-Sided

1. Pull out the unit and disconnect the power cord.
2. Remove screw on left side as shown below. Repeat steps to remove screw on right hand side. The screws may be discarded.

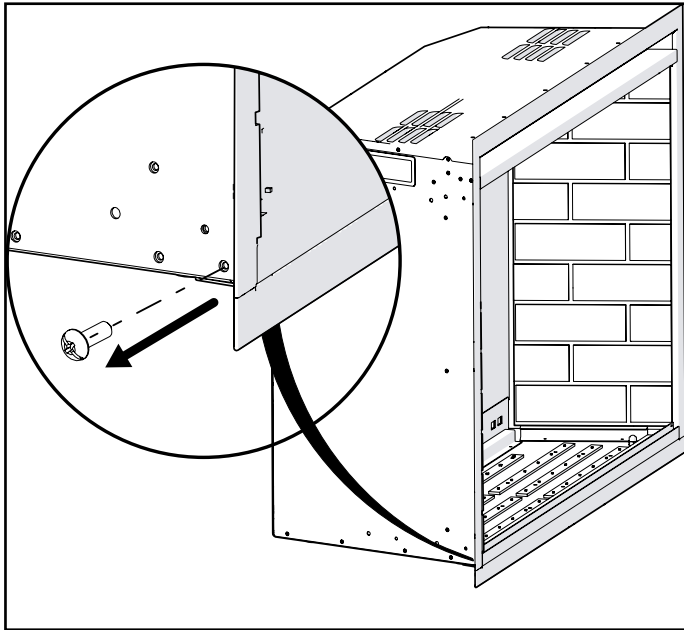

3. Install the faceplate from the top, then pull forward.

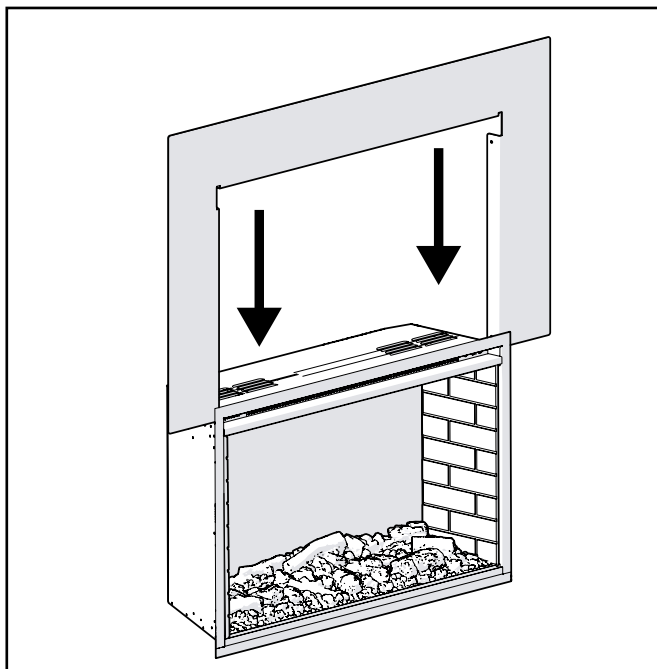

4. Fasten the four screws on both sides to attach the faceplate.

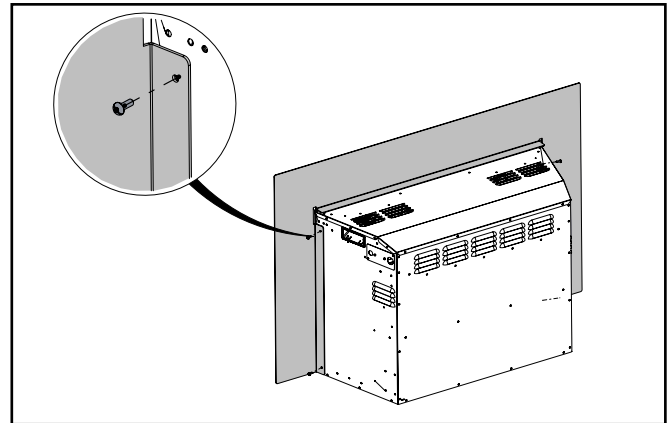

5. Faceplate installed.

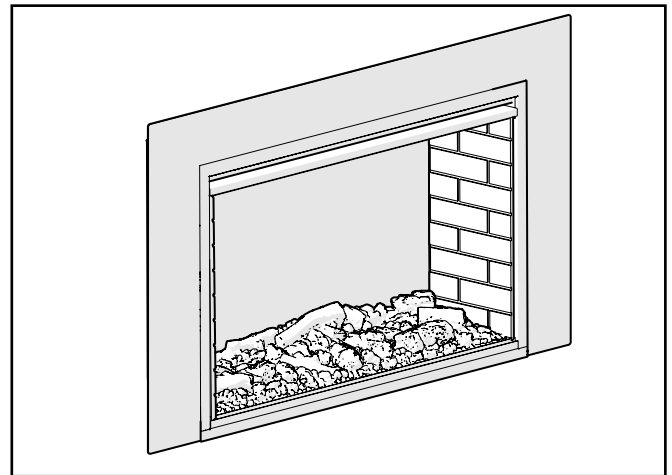

6. Plug the unit into the power outlet, and position it in its original location.

### Premium Faceplate Surround Installation

These instructions are for use with the following products:

PART #	Description
311-920	Faceplate Surround Black
311-921	Faceplate Surround Grey
311-922	Faceplate Surround White
311-923	Faceplate Surround Sunset Bronze
311-924	Faceplate Surround Brushed Nickel

1. Gently slide the faceplate surround on from the top.

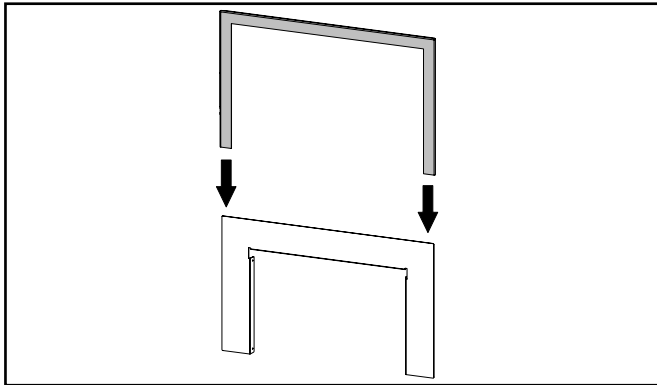

2. If using a Gi29 flush faceplate, place the magnets on face A. If using an Ei29 flush faceplate, place the magnets on face B. One magnet per bracket.

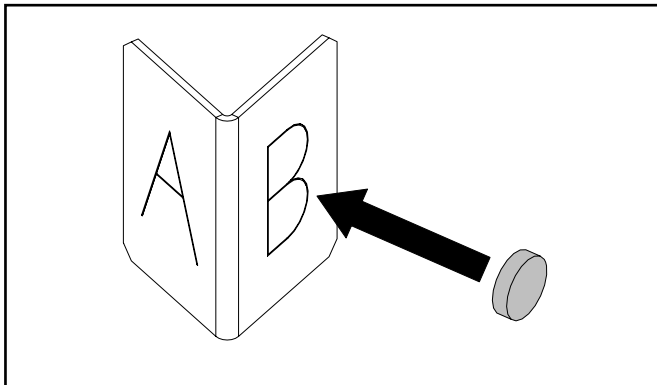

3. Ensure the faceplate and faceplate surround are pressed against each other. Insert the brackets on both sides, top and bottom.

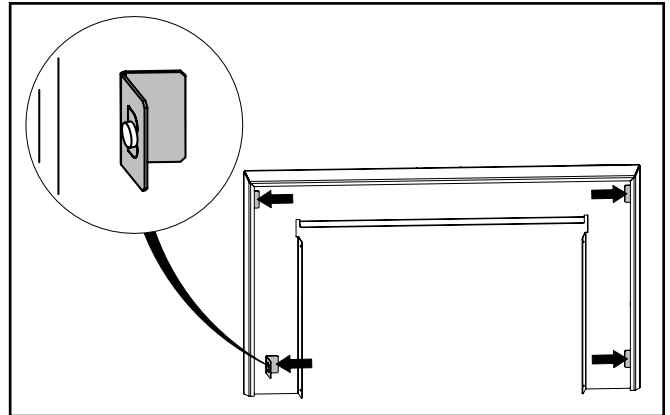

4. Faceplate surround installed.

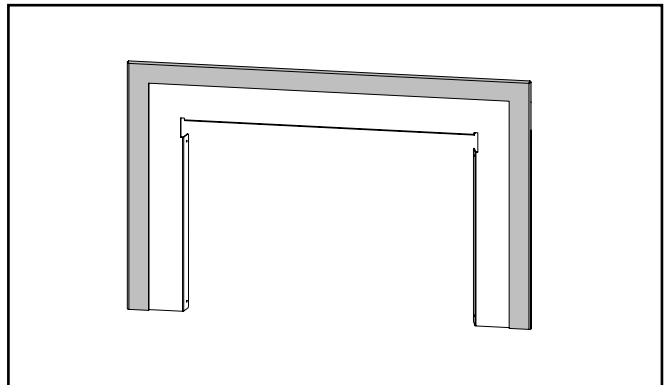

5. Lift the faceplate and faceplate surround up from this flange, as shown, and refer to "Faceplate / Finishing Trim Installation".

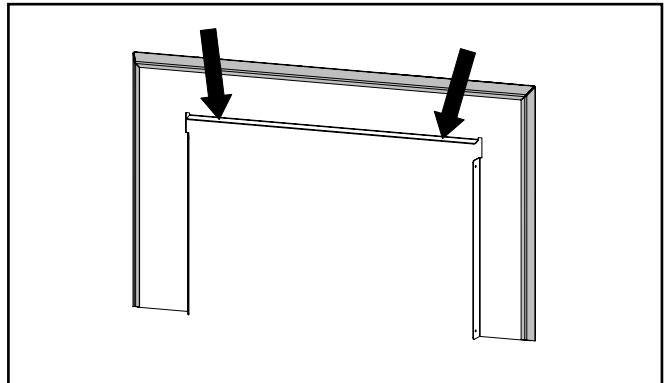

### Faceplate Surround Installation

These instructions are for use with the following products:

PART #	Description
311-927	Faceplate Traditional Surround Black
311-928	Faceplate Traditional Surround Brushed Antique Copper

1. Slide the corner clips in on either end.

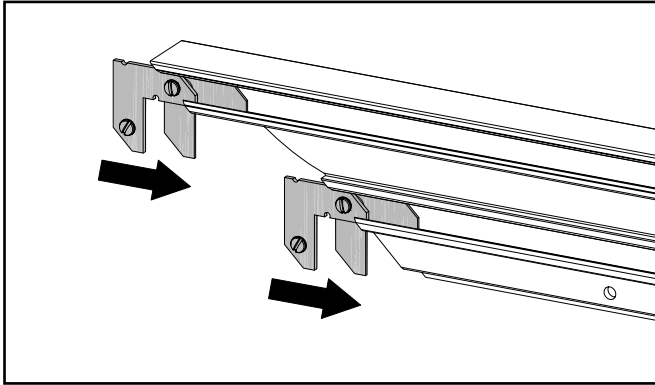

2. Tighten the top screws (x4).

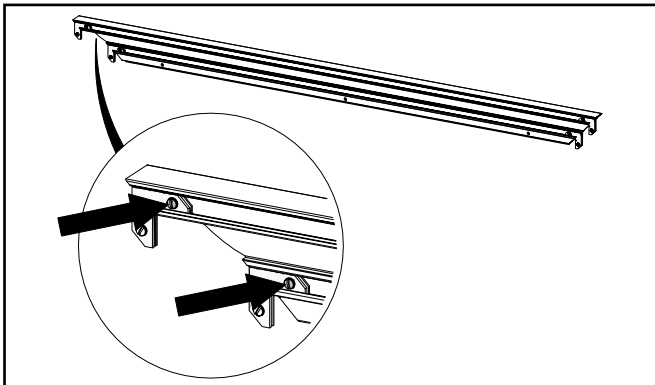

3. Slide the side pieces on.

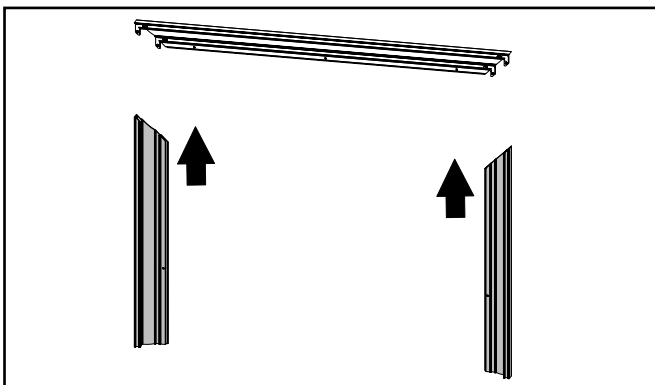

4. Tighten the bottom screws (x4).

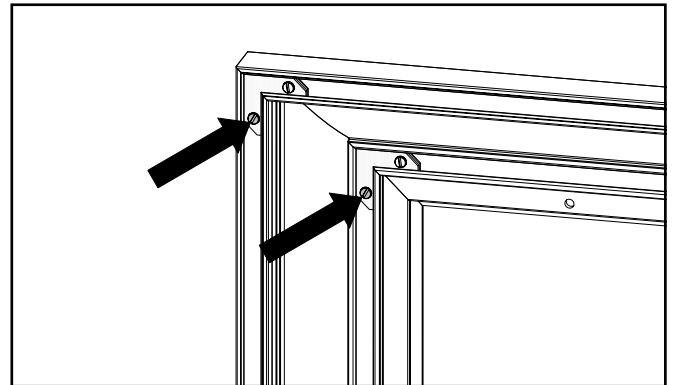

5. Gently slide the traditional surround on from the top.

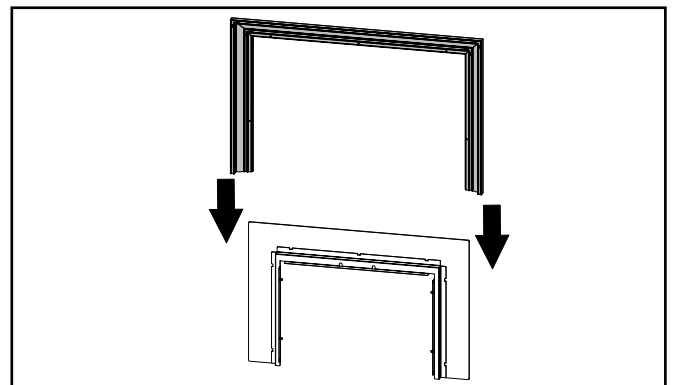

6. Insert and tighten the rear screws (x5). Traditional surround installed.

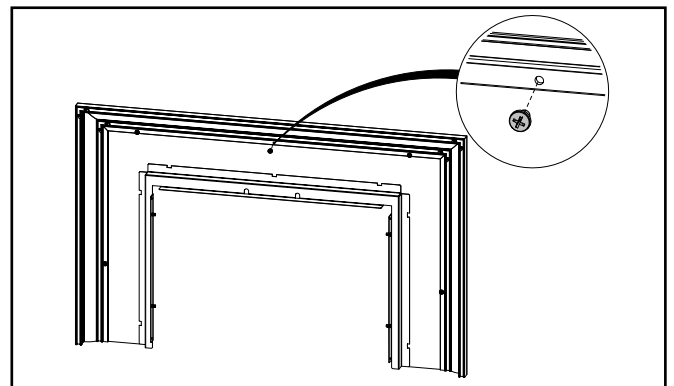

7. Lift the faceplate and traditional surround up from here and refer to "Faceplate / Finishing Trim Installation".

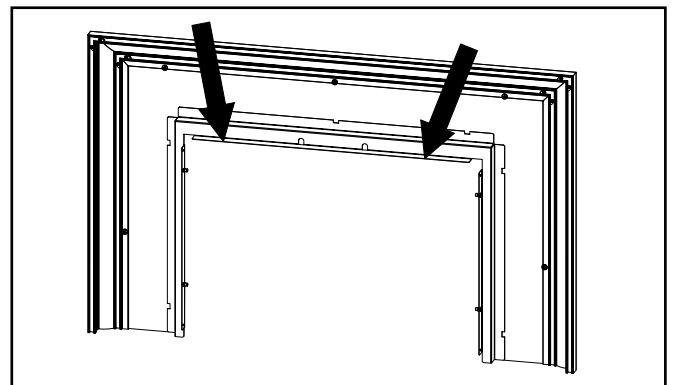

### 4-Sided Faceplate Installation

These instructions are for use with the following products:

Remove screw on left side as shown below. Repeat steps to remove screw on right hand side. The screws may be discarded.

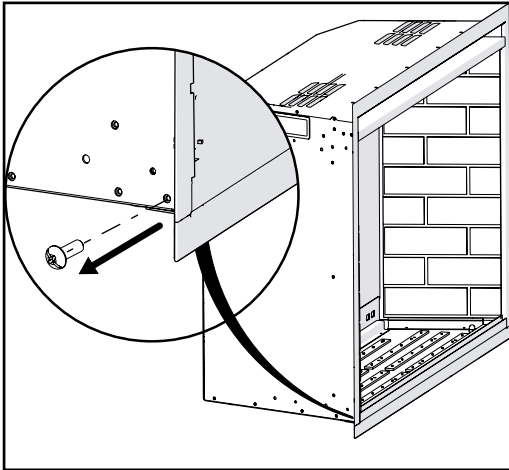

PART #	Description
281-913	Faceplate 4-Sided Flush
281-938	Faceplate Custom 4-Sided

1. Remove the front glass with the suction cup provided.
2. Using a clean sheet or cardboard on the floor for protection, flip the unit onto its front face.

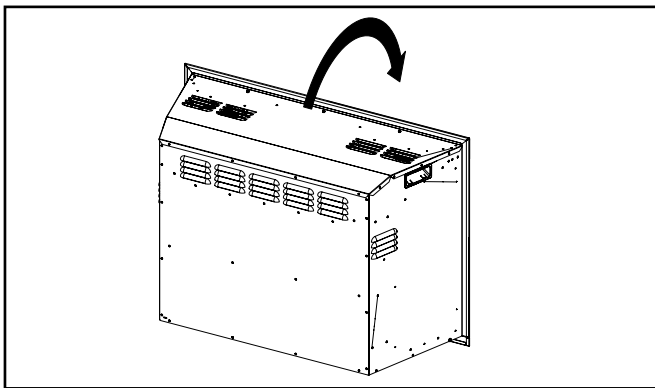

3. Remove the four screws supplied with the faceplate.

4. Install the faceplate from the top. Ensure the correct orientation, with the shorter flange located below the unit.

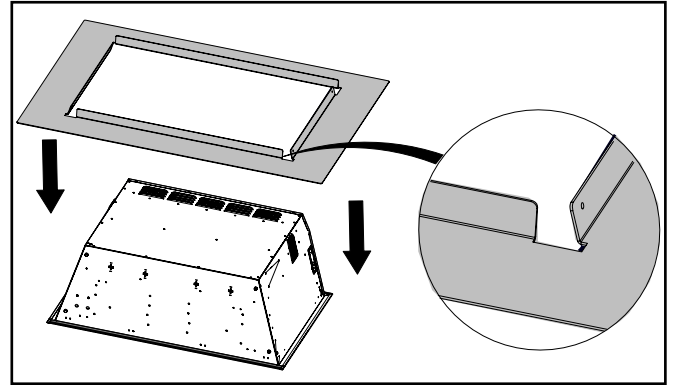

5. Fasten the four screws on both sides to attach the faceplate.

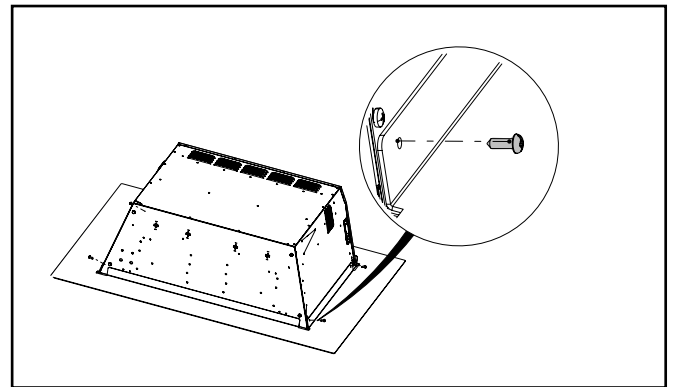

6. Flip the unit upright. 4-Sided faceplate installed.

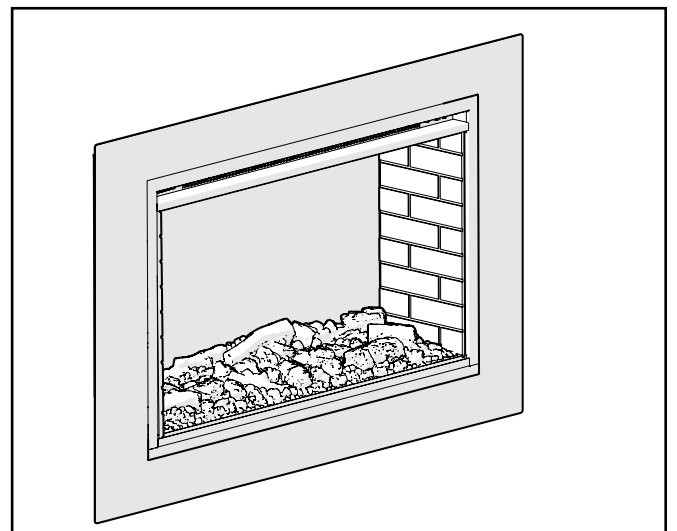

### Backing Plate Installation

These instructions are for use with the following products:

PART #	Description
281-936	Backing Plate 3-Sided Oversized

1. If installing a 3-sided faceplate, premium surround or traditional surround, refer to their relevant instructions now.

2. Remove the eight screws supplied with the backing plate.

3. Attach the brackets on both sides using the four screws provided.

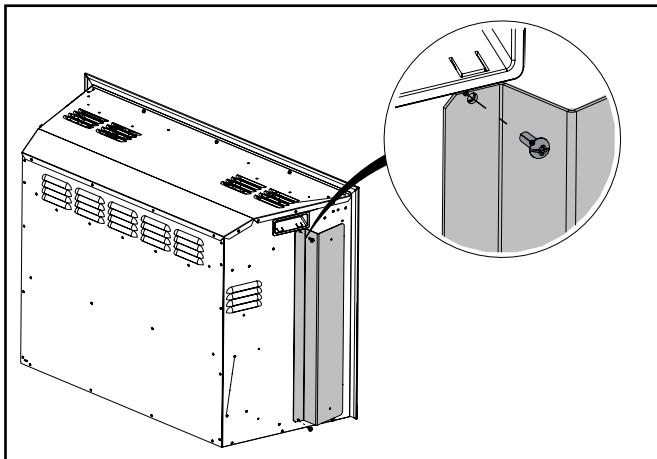

4. Install the backing plate from the back.

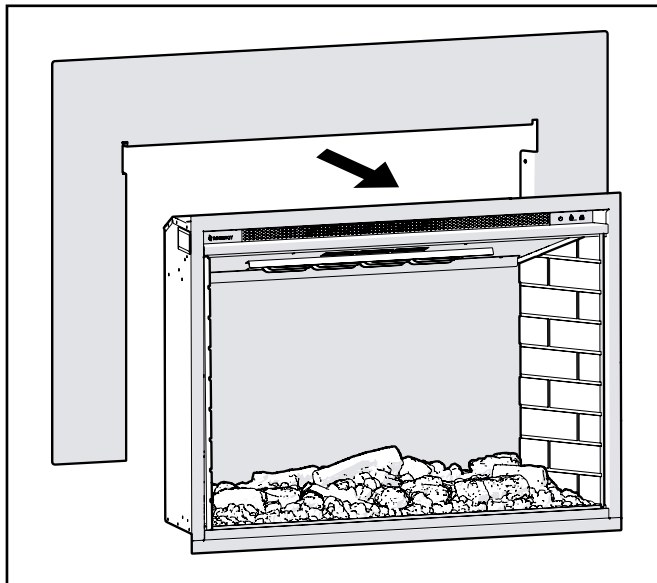

5. While pulling the backing plate forward, fasten the four remaining screws on both sides to attach the backing plate.

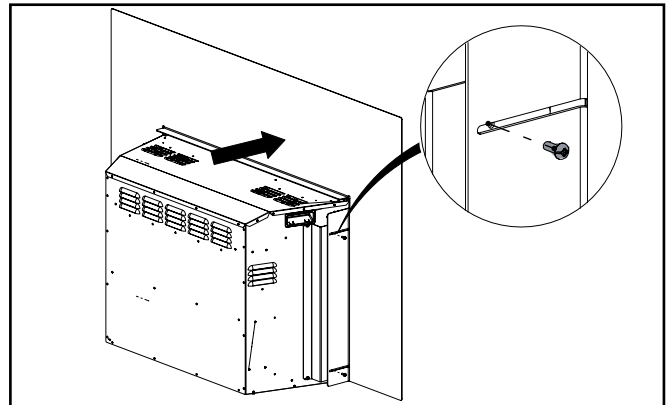

6. Backing plate installed.

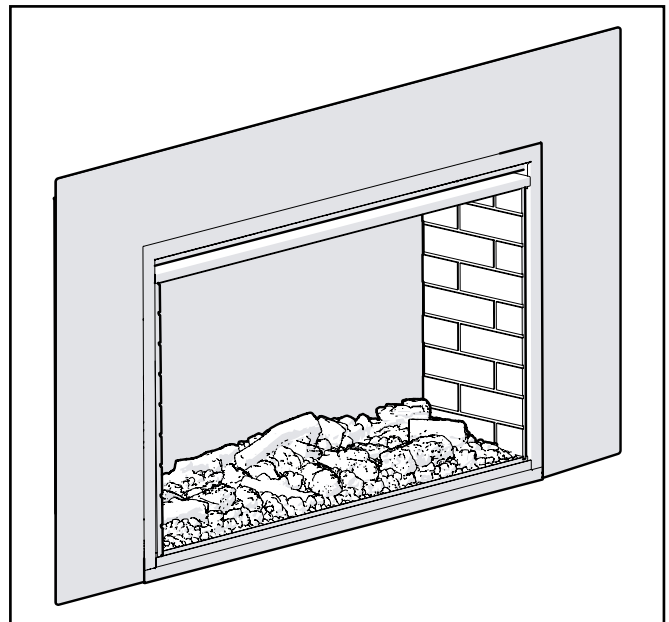

## OPTIONAL LED MOOD LIGHTING KIT (PART #923-835)

The appliance can be enhanced by an optional LED Mood Lighting Strip. This comes with 10' (3 m) of LED mood lighting and can be operated using the remote control provided with this appliance. A second LED mood kit strip may be obtained if more than 10' (3m) is required. This can be connected to the end of the first LED lighting strip or by using the splitter that is provided with the kit. A maximum of 3 kits is permitted.

### Contents

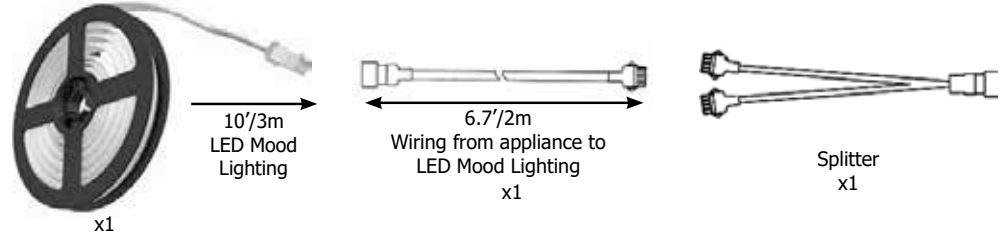

### Installation

- 1 Locate pigtail on right hand side of appliance. Connect other end of LED mood lighting kit to the pigtail as shown below.

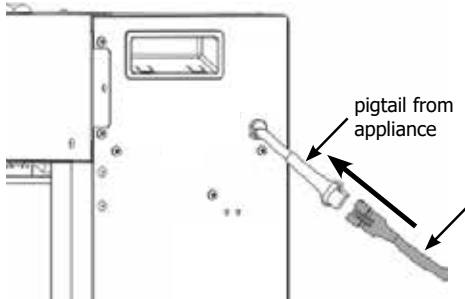

- 2 Cut LED strip to desired length. Ensure cut line is as per below.

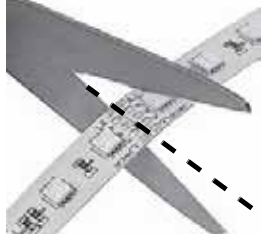

- 3 Peel adhesive from back side of LED strip.

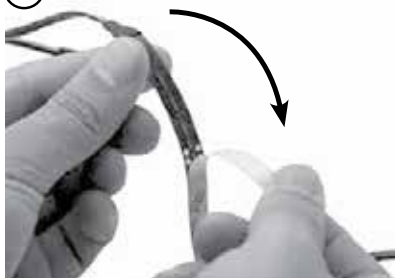

- 4 Stick the LED strip on the desired surface, as shown below.

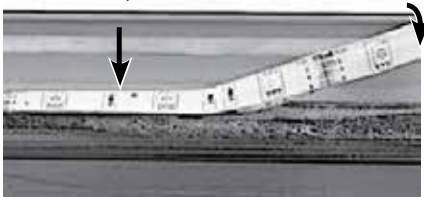

### Maximum Length: ≤20'/6m

- 1 Maximum 20' (6m) with no splitter required. If more than 10' (3m) is required a second 923-835 LED Mood Lighting Strips would need to be purchased.

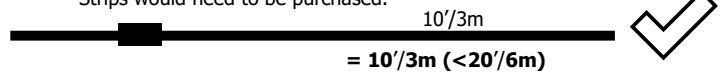

- 2 Maximum 20' (6m) using supplied splitter. 2 x 923-835 LED Mood Lighting Strips required.

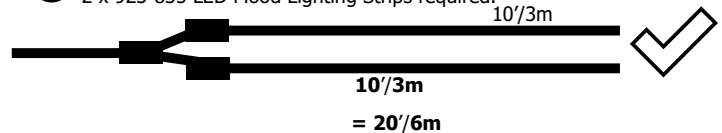

- 3 Maximum 20' (6m) with splitter from the original kit & additional splitter from second LED mood lighting strip kit purchased. 3 x 923-835 LED Mood Lighting Strips required.

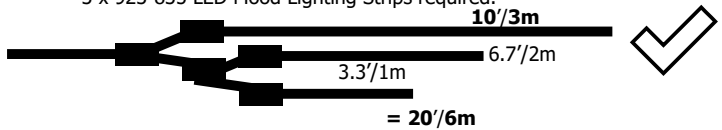

- 4 Not permitted

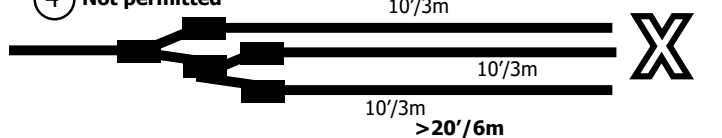

**Example** 2 x 923-835 Mood Lighting strip kit & 1 x splitter and 1 x wiring from appliance to LED mood lighting used. See below.

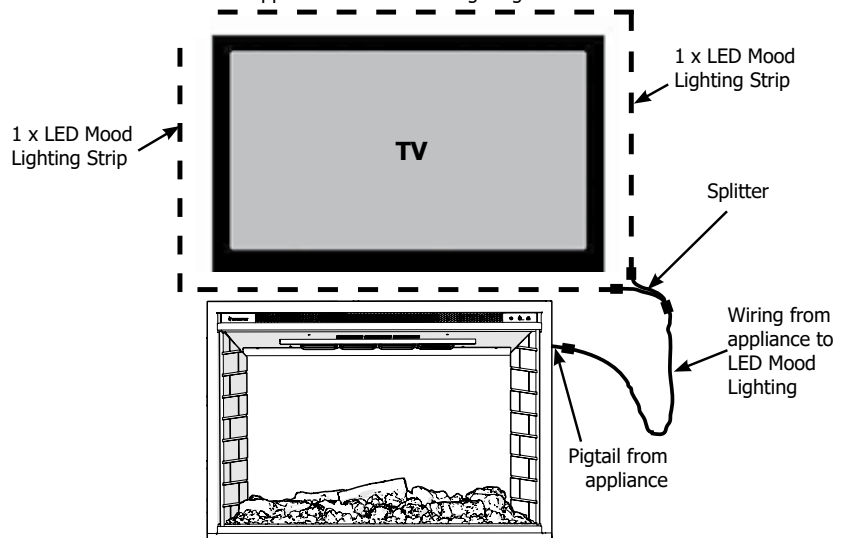



**OPTIONAL BROWN BRICK PANEL (PART #281-961)**

Brick panel installation guide.

Before you begin keep the area around the appliance clean.

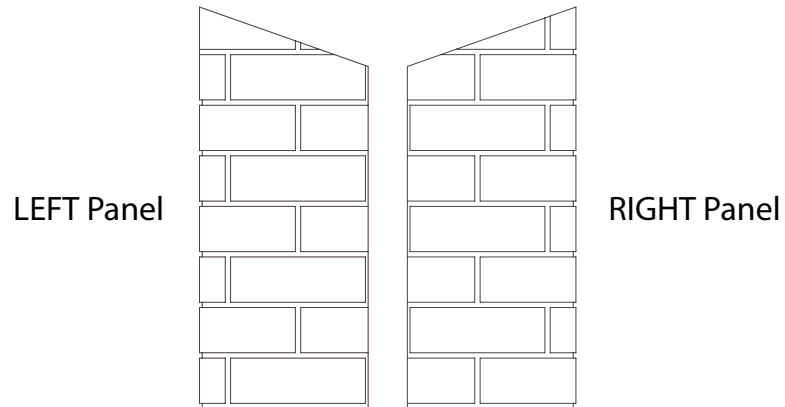

1. Pull out the unit and disconnect the power cord.

2. Carefully use the glass suction lifter provided to remove the glass. Remove the front glass of the unit, as shown in illustrations A, B and C.

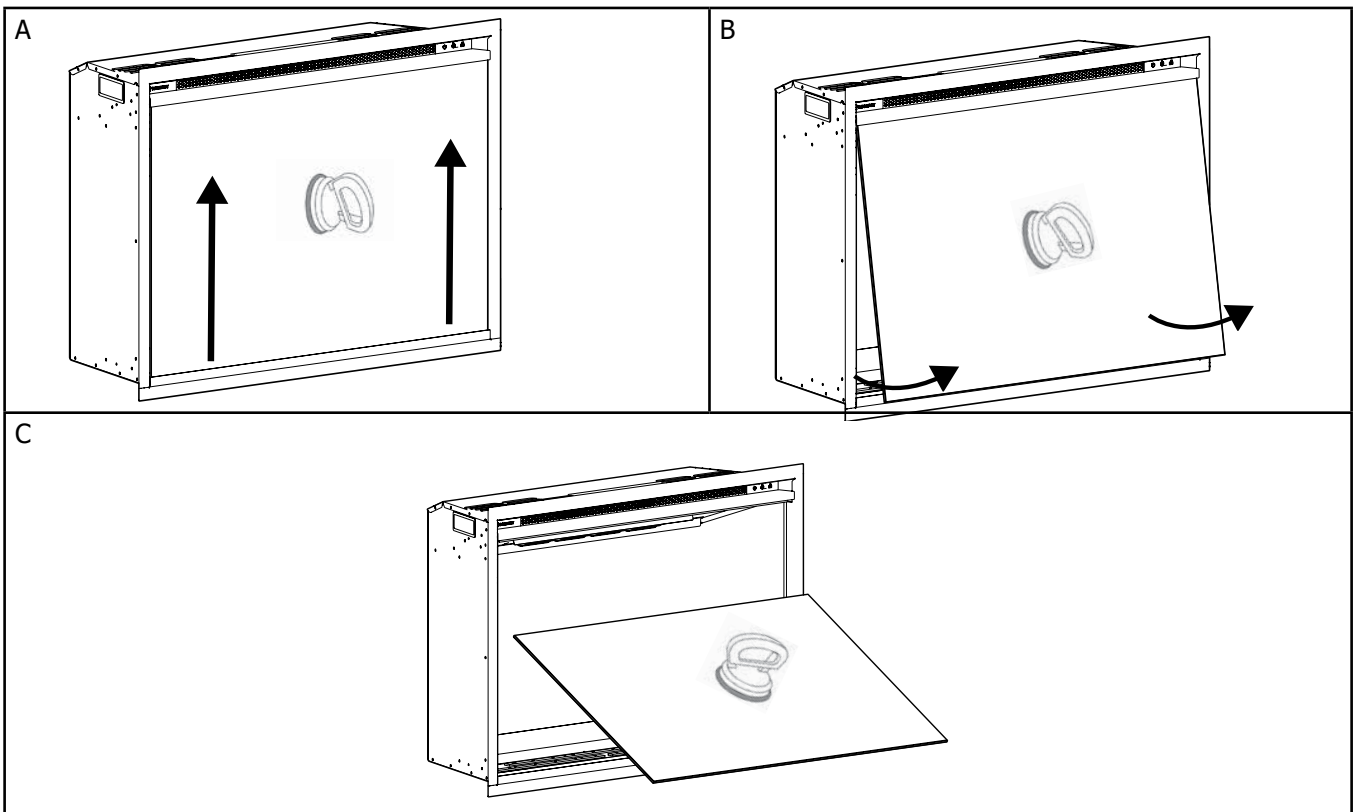

3. Remove the log set and ember bed. Ensure that the logs are repositioned in the same orientation at the end of the process.

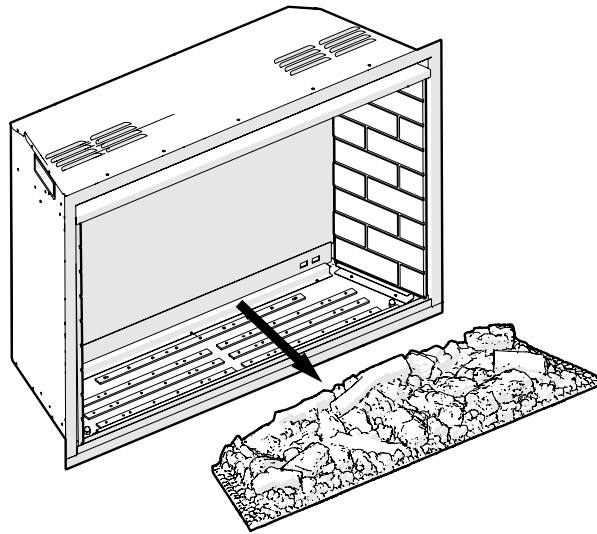

4. With the logs and ember bed removed, remove the three screws on the side of the unit, as shown in the image below.

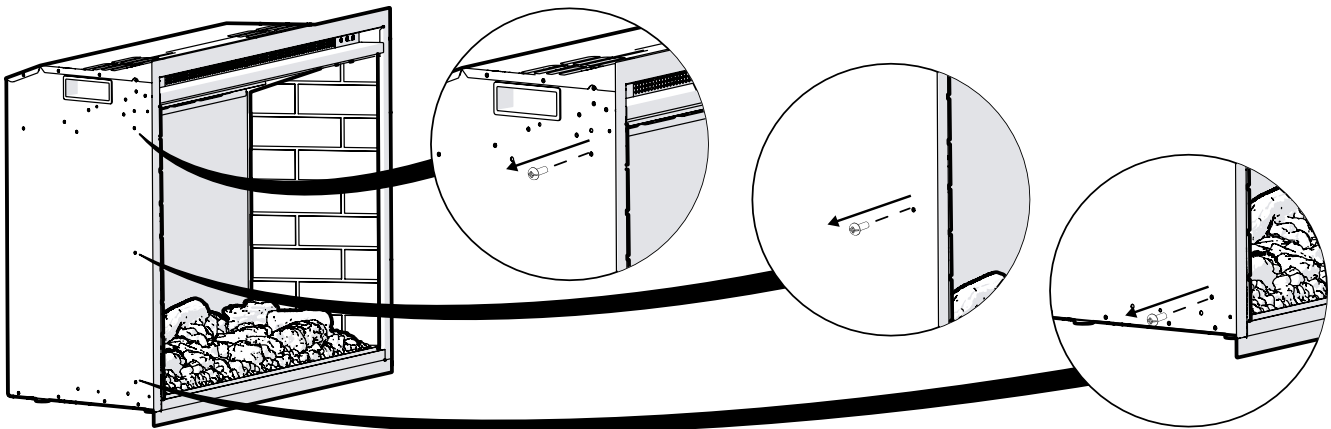

5. After removing the screws, rotate the black brick panel and pull it off as shown in illustrations D and E.

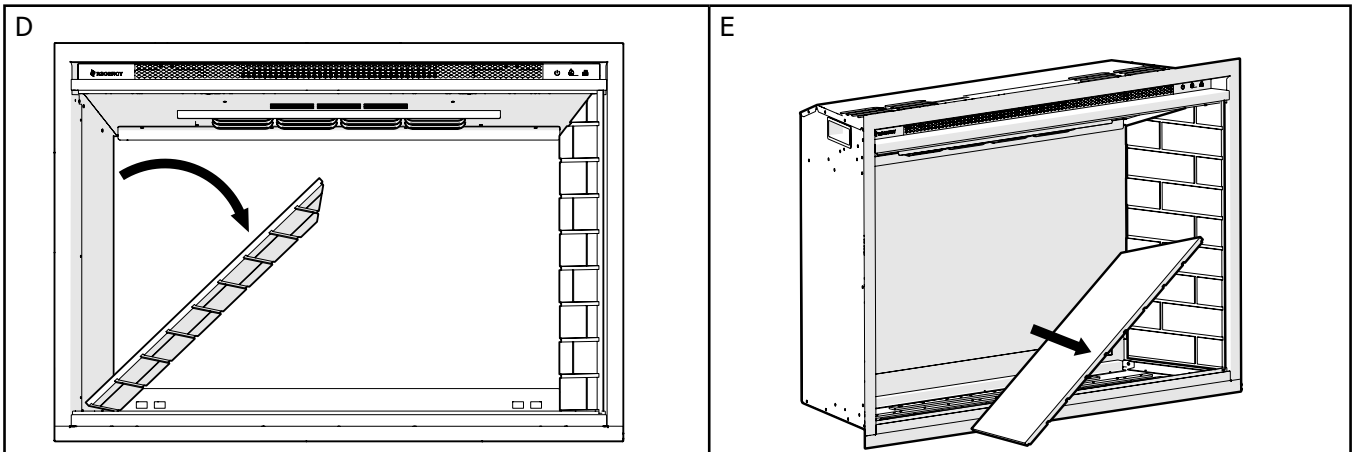

6. Replace the brick panel and attach with the screws removed in step 4.

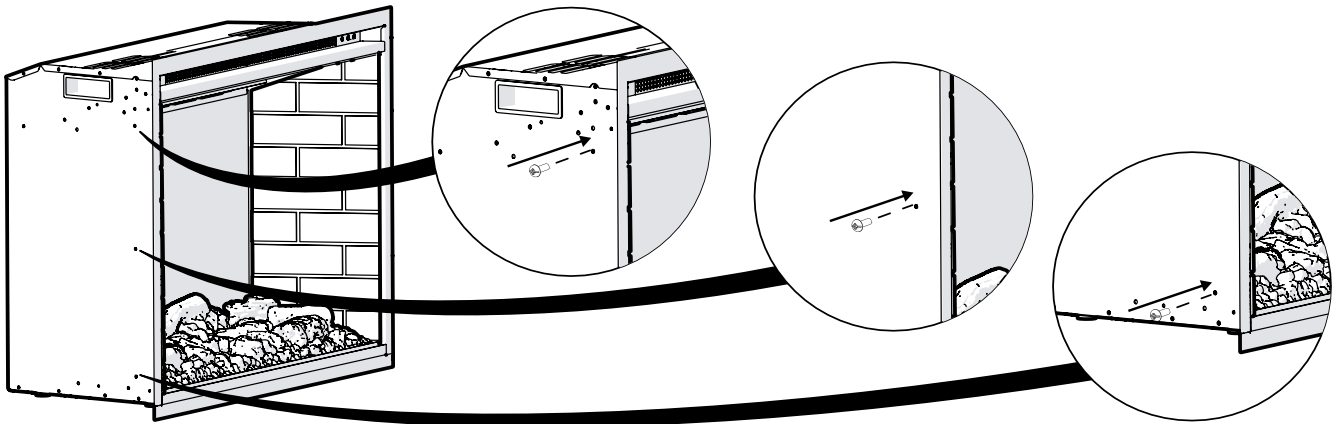

7. With the panels installed, place the ember bed and log set back into the unit. Plug the unit into the power outlet, and position it in its original location.

Follow steps F, G, H below to install the front glass back inside the channel, in it's original position.

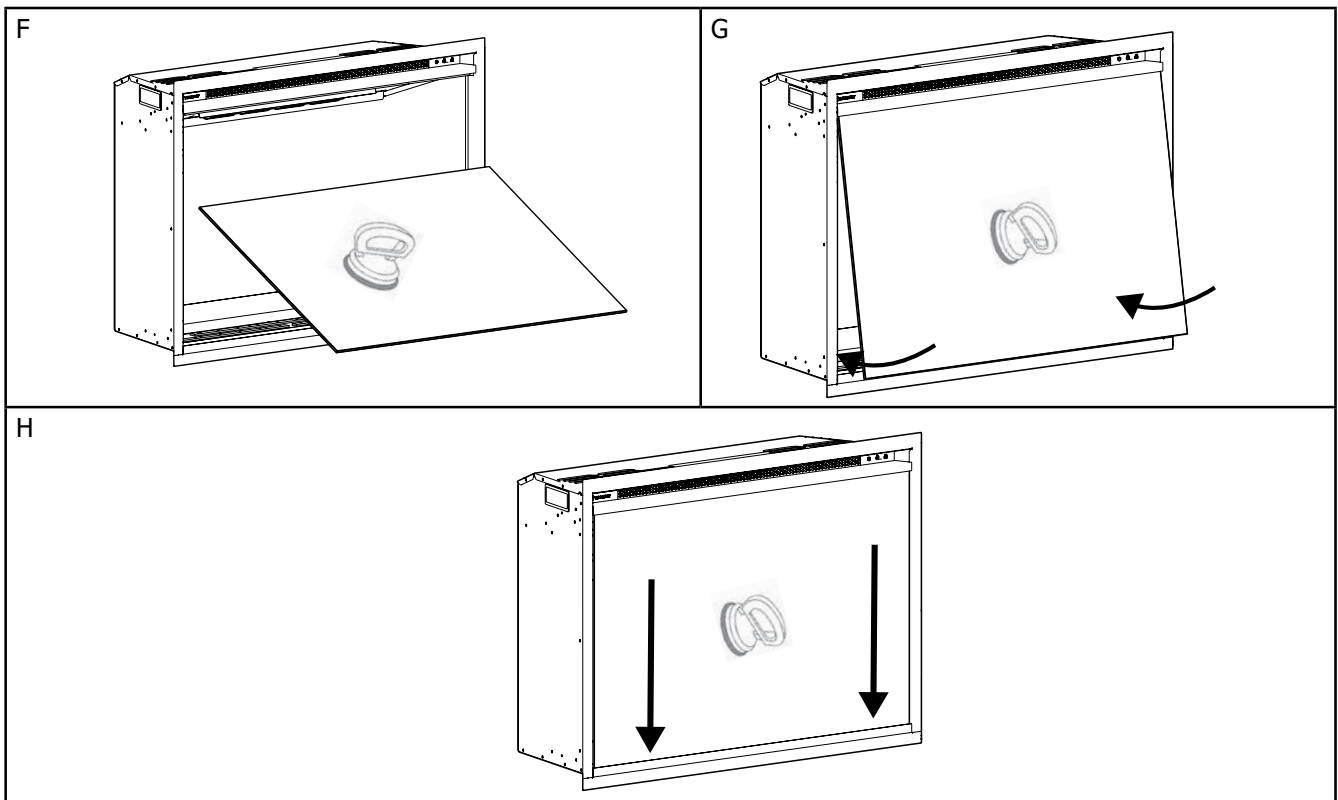

## OAK LOG SET (PART #281-954) AND DRIFTWOOD LOG SET (PART #281-950)

Oak log shown steps are also applicable for driftwood log set.

Log A (x1)		Log B (x1)		Log C (x1)		Log D (x1)		Log E (x1)	
Top View	Bottom View	Top View	Bottom View	Top View	Bottom View	Top View	Bottom View	Top View	Bottom View

Log set installation guide.

1. Position log A as shown.

Ensure that the cut out section on the bottom of the log A is facing downward onto the emberbed and the N end of the log is pointing towards the back corner right of the ember bed.

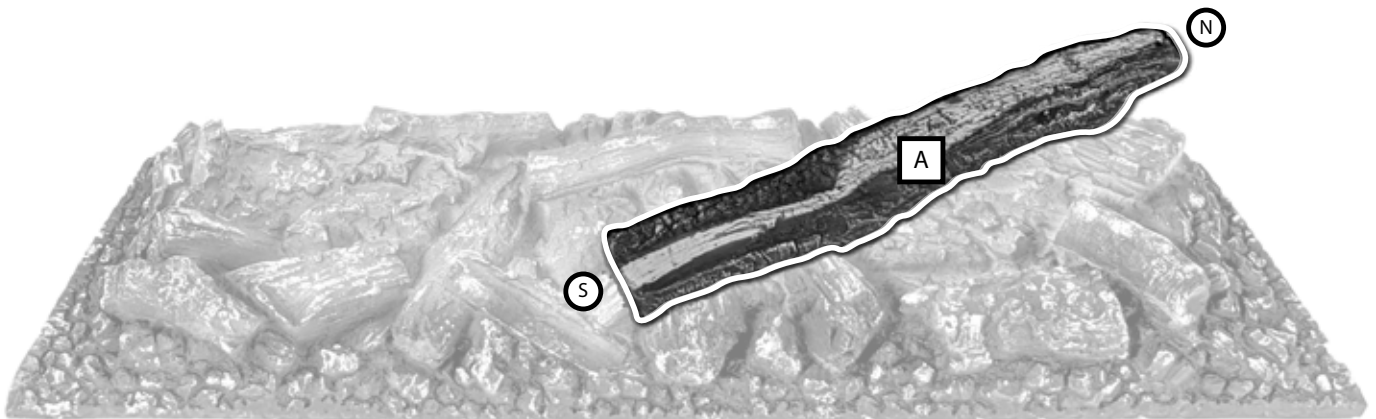

2. Position log B as shown, resting against log A. Ensure that the cut out section on the bottom of the log B is facing downward onto the emberbed and the N end of the log is pointing towards the back corner left of the ember bed.

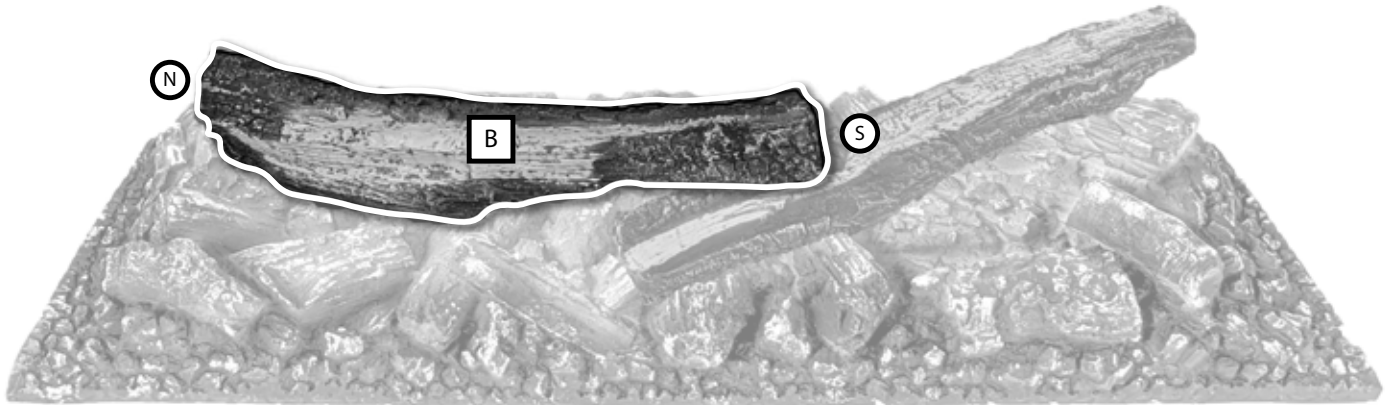

3. Position log C as shown. Ensure that the flat face on the bottom of the log C is facing downward onto the emberbed and the S end of the log is pointing towards the front center of the ember bed.

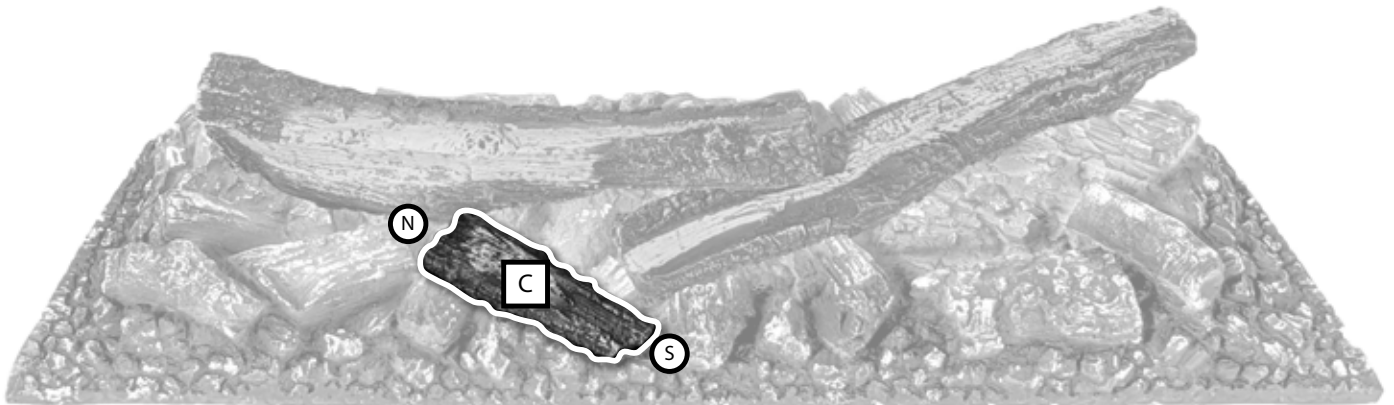

4. Position log D as shown, resting against log A. Ensure that the cut out section on the bottom of the log D is facing downward onto the emberbed and the S end of the log is pointing towards the front right corner of the ember bed.

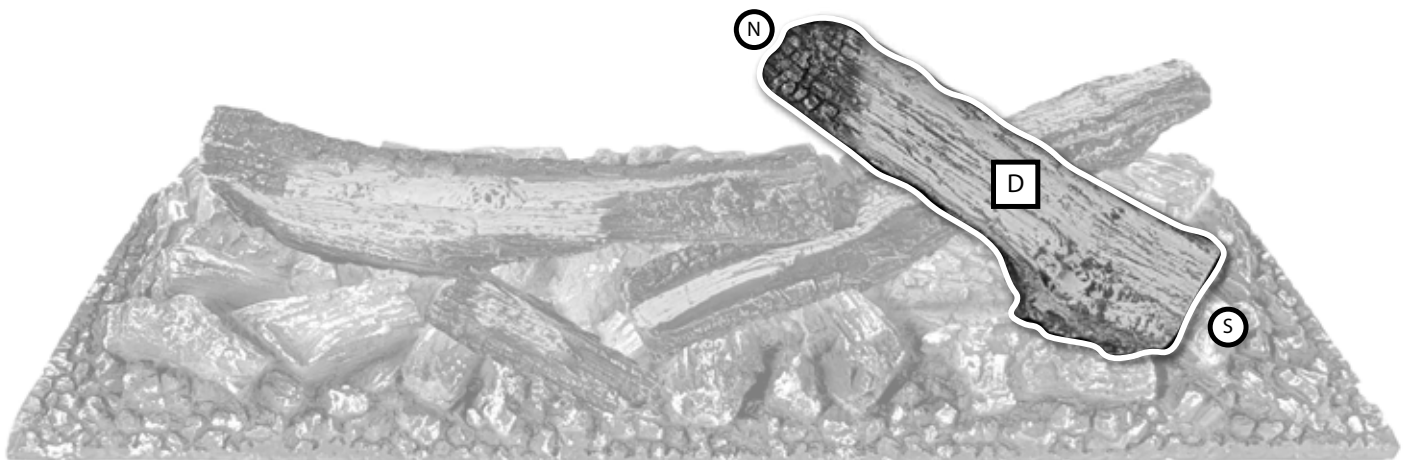

5. Position log E as shown, resting against log B. Ensure that the cut out section on the bottom of the log E is facing downward onto the emberbed and the S end of the log is pointing towards the front left corner of the ember bed.

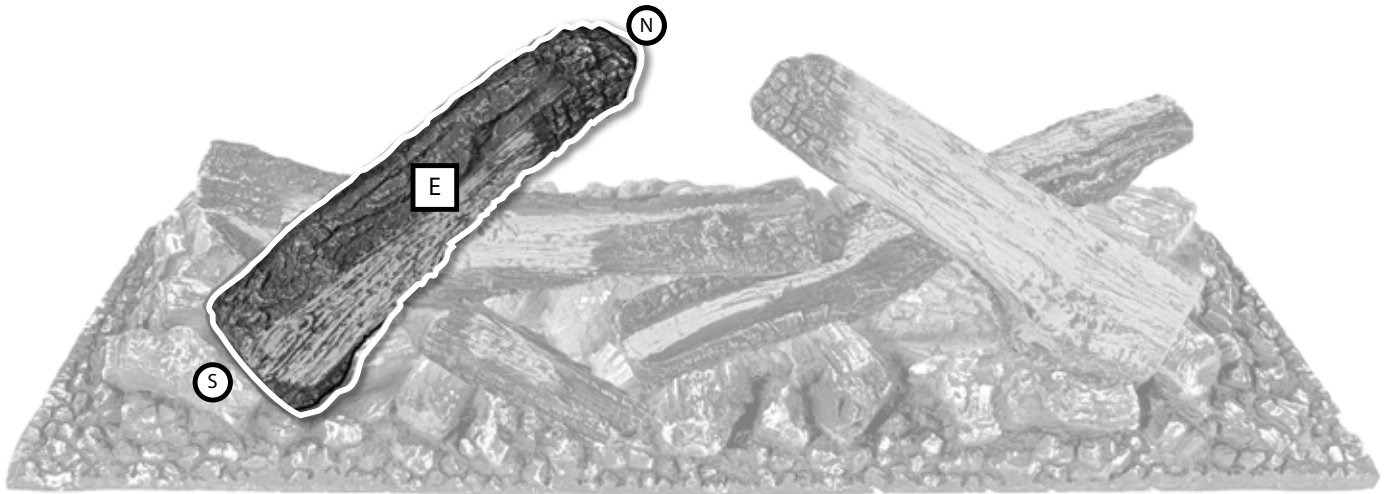

6. Oak or Driftwood log layout complete as shown below.



**BIRCH LOG SET (PART #281-951)**

Log A (x1)		Log B (x1)		Log C (x1)		Log D (x1)		Log E (x1)	
Top View	Bottom View	Top View	Bottom View	Top View	Bottom View	Top View	Bottom View	Top View	Bottom View

Log set installation guide.

1. Position log A as shown.  
Ensure that the cut out section on the bottom of the log A is facing downward onto the emberbed and the N end of the log is pointing towards the back corner right of the ember bed.

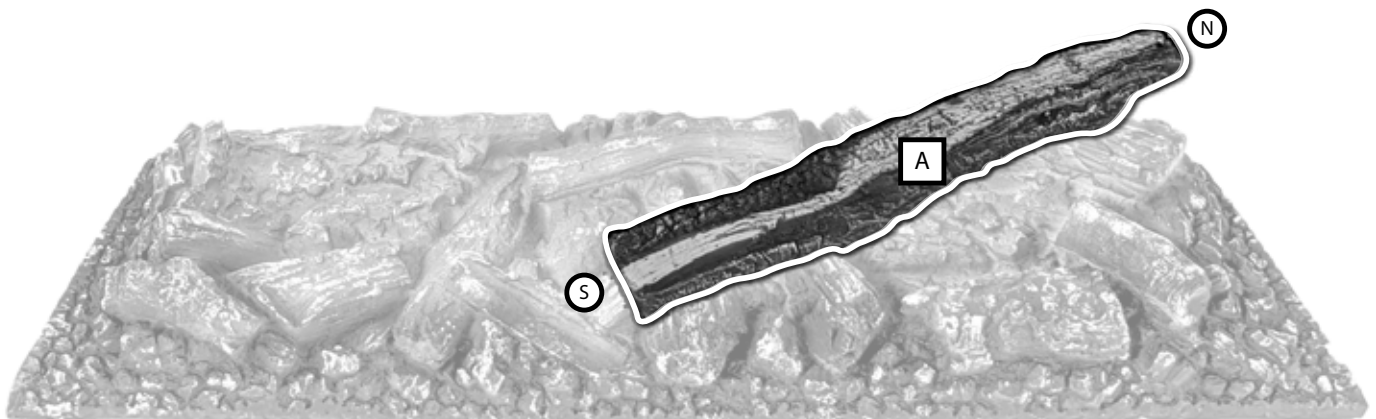

2. Position log B as shown, resting against log A. Ensure that the cut out section on the bottom of the log B is facing downward onto the emberbed and the N end of the log is pointing towards the back corner left of the ember bed.

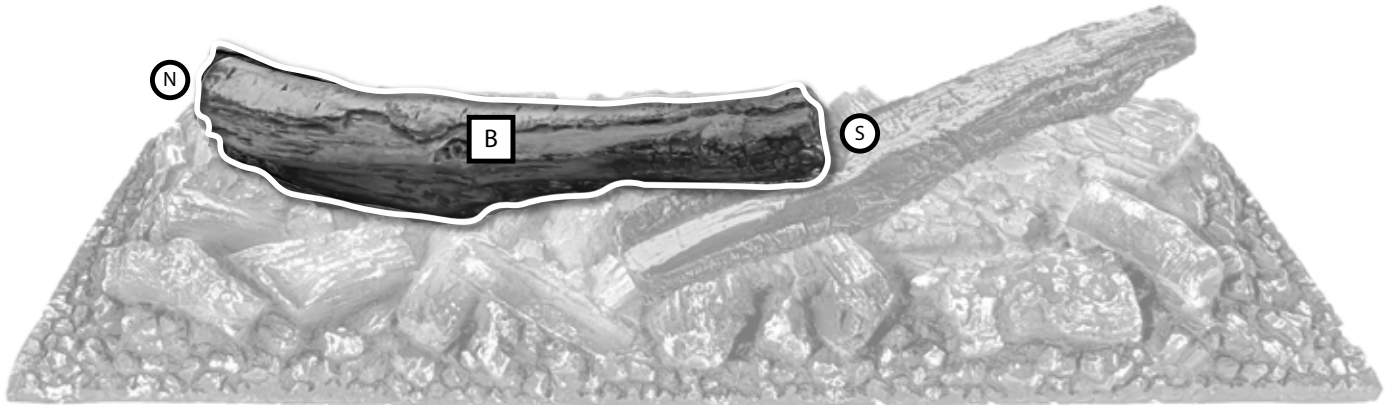

3. Position log C as shown. Ensure that the flat face on the bottom of the log C is facing downward onto the emberbed and the S end of the log is pointing towards the front center of the ember bed.

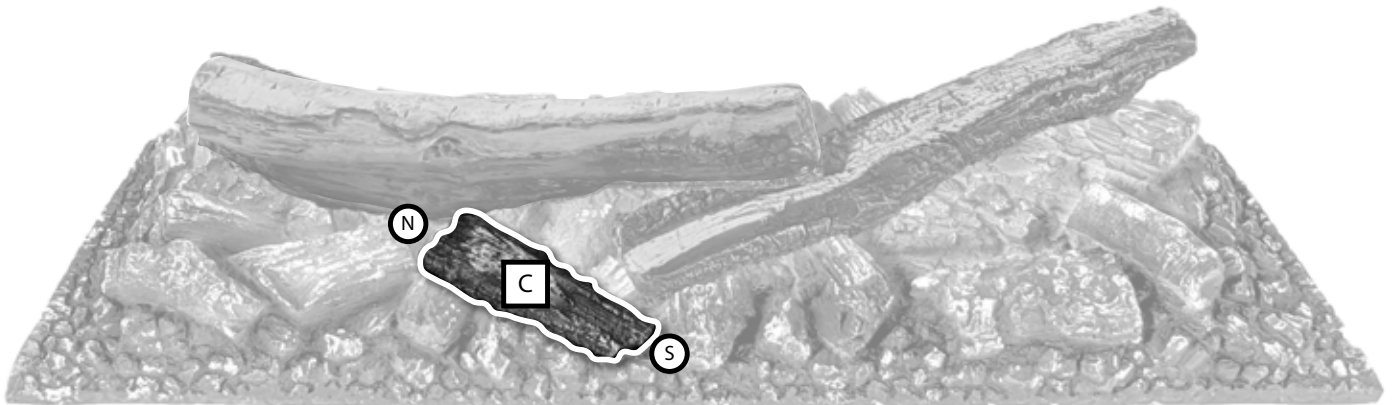

4. Position log D as shown, resting against log A. Ensure that the cut out section on the bottom of the log D is facing downward onto the emberbed and the S end of the log is pointing towards the front right corner of the ember bed.

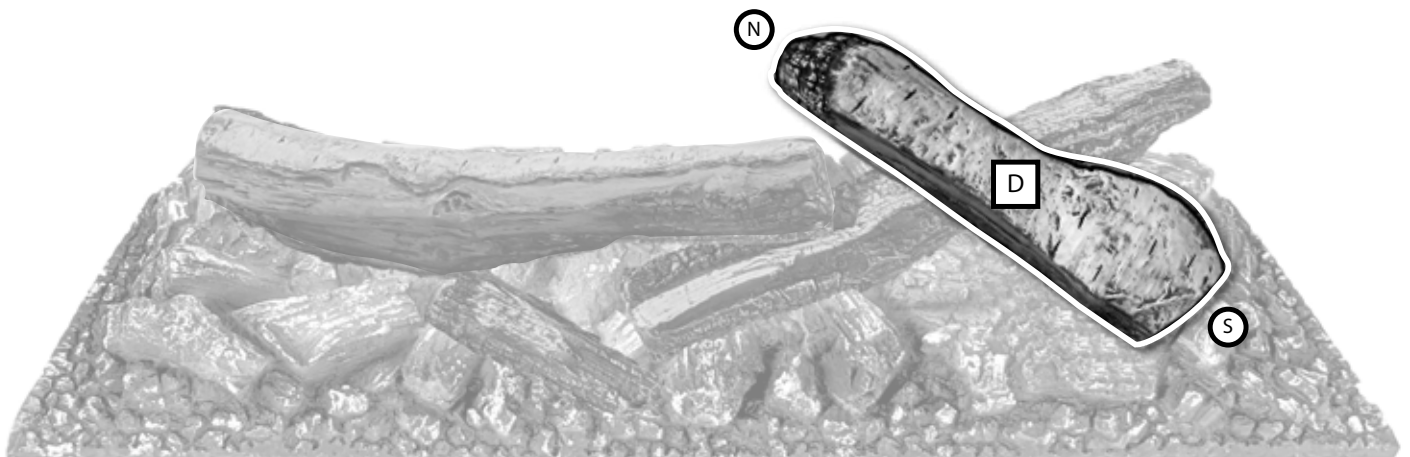



5. Position log E as shown, resting against log B. Ensure that the cut out section on the bottom of the log E is facing downward onto the emberbed and the S end of the log is pointing towards the front left corner of the ember bed.

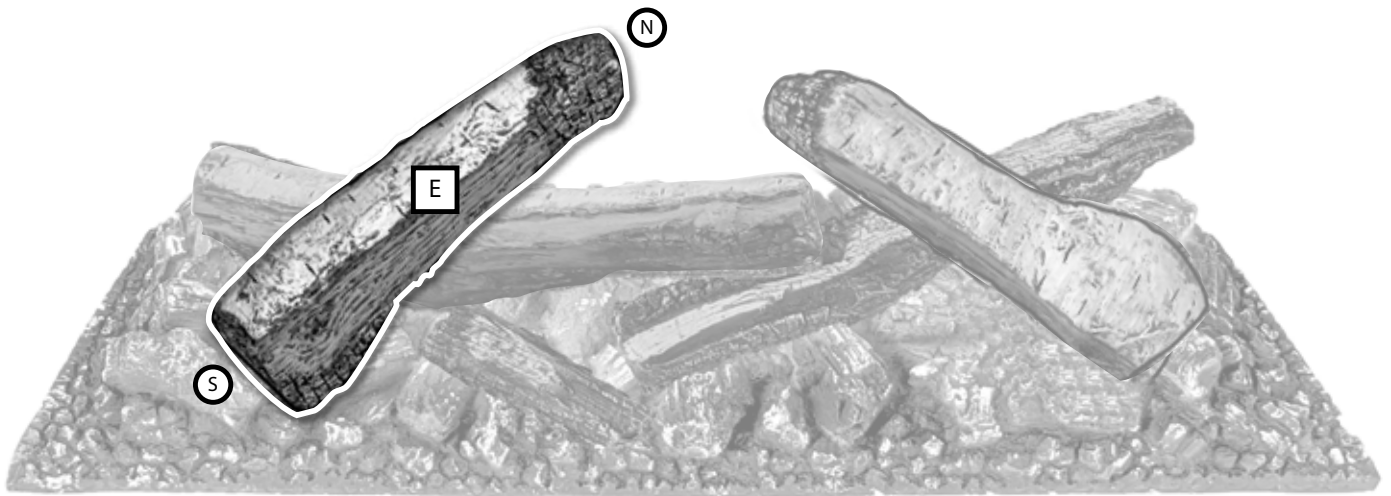

6. Oak or Driftwood log layout complete as shown below.



## SERVICE INSTRUCTIONS

**IMPORTANT:**

- Always shut off power prior to servicing this appliance.
- Label all wires prior to disconnection when servicing controls. Wiring errors can cause improper and dangerous operation.
- Ensure that the wires do not touch any hot surfaces and are away from sharp edges.
- It is recommended that the service be performed by a qualified professional.

**Access to ember light strips, LED screen and screen layer**

1. Remove front glass.

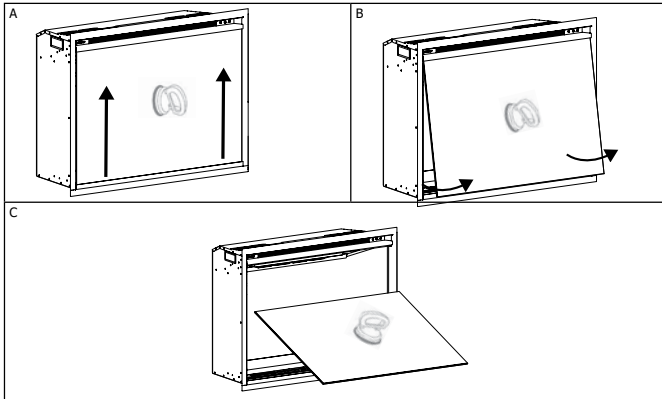

2. Remove log set & ember bed.

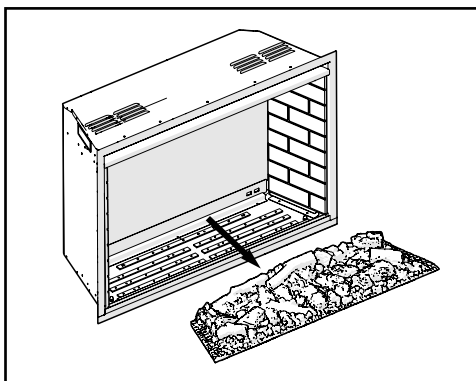

**Ember bed light strips connection**

1. Replace ember light strips. Once Logs and ember bed have been removed the ember light tray will be exposed as shown below.



2. To remove the ember bed light strips, remove the logs and ember bed, start by gently squeezing and pulling

each strip upward to detach it from the black securing post. Once all seven ember strips have been removed, disconnect each Molex connector linking the strips together. Note that one of the Molex connectors is secured with a zip tie, which will need to be carefully cut to free the ember light wire harness.

After the zip tie is removed and all connections are detached, proceed with replacing the ember bed light strip. Once replaced, secure the new strips firmly onto the black securing posts and ensure they are stable. Finally, reconnect all the Molex connectors and verify the stability of the entire assembly.

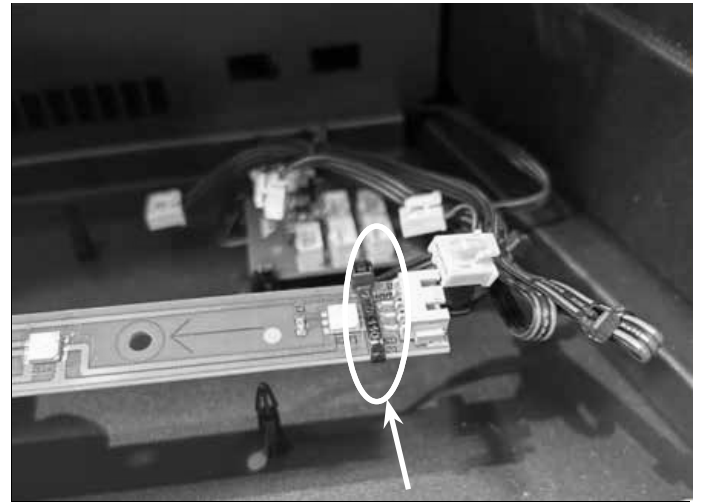

**LCD screen glass layer access**

1. Remove rear glass panel. Remove the unit from the cavity and remove the glass and media including the ember bed, logs and brick panels, remove the retainer bracket held in place with 4 x Philip head screws as shown below.



2. Once the retainer bracket has been removed the rear glass can be removed by tilting the glass forward and lifting outward.



**NOTE:** the LCD screen will also move with the rear glass care must be taken not to damage the LCD screen.

**LCD screen connection & access**

**Steps for Removing the LCD Screen:**

1. Open the top and back covers to expose the power board and multimedia video board.

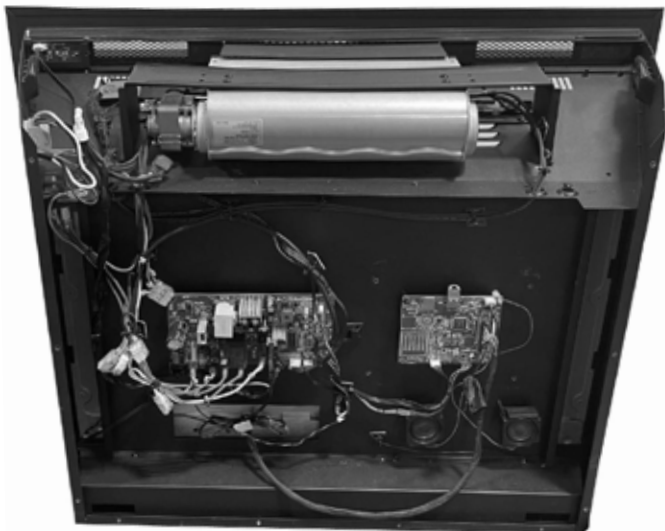

2. Disconnect the screen's power cable from the power board (1) and the data cable from the video board (2).

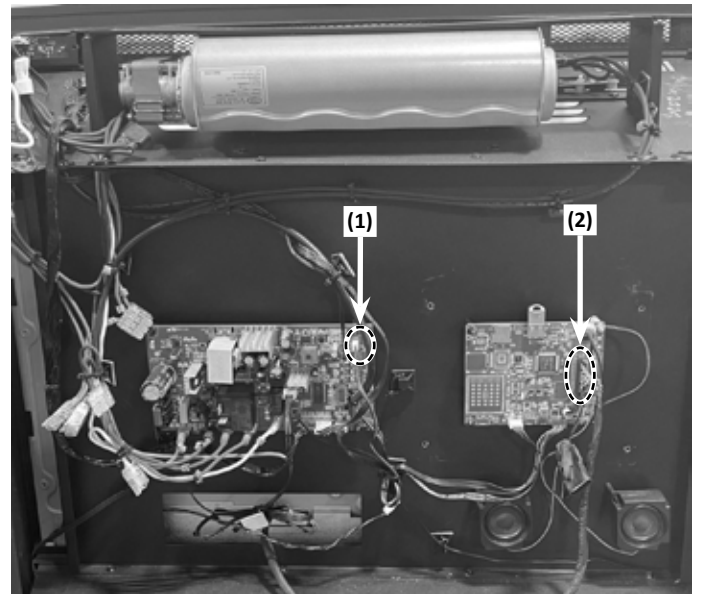

3. Remove the protective strip from the top of the LCD screen's front glass. Caution: As you remove the front glass, the LCD screen must be supported with an appropriate object to prevent it from falling out of the fireplace chamber.

4. Carefully remove the LCD screen from the chamber.



**Important:** The LCD screen and its connections are fragile electrical components. Handle with extra care and gentleness to avoid damage.

**Electric Circuit Board Access:**

**Remove the Access Panel:**

1. Disconnect the power supply and carefully extract the unit from the cavity. Position the unit to facilitate access to the rear access panel, as illustrated below. Remove the six Phillips head screws, located as indicated, to access the main control board.



**Detach the Control Board:**

With the access panel removed, you may now proceed to detach the control board. To do so, press in on the four vertical black posts while simultaneously and carefully pulling each corner of the control board to disengage it. Once the board has been detached, observe, and document the positions of the Molex connectors for future reference. Proceed to disconnect each connector and then install the replacement control board.

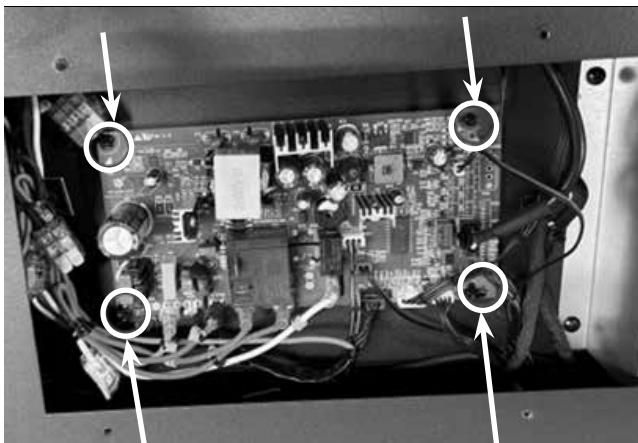

**Important:**

**Document Wire Connections:**

Before disconnecting any wires, take note of the positions and configurations of all Molex connectors.

Ensure each connector is clearly labeled or documented for proper reinstallation.

**Disconnect the Connectors:**

Proceed to disconnect each Molex connector one at a time. Ensure all wires follow the proper connection codes and are securely fastened. Inspect for any loose or damaged wires and address any issues before proceeding.

**Install the Replacement Electric Circuit Board :**

Position the new control board, ensuring it is aligned with the mounting posts. Carefully reconnect each Molex connector according to the documented positions, ensuring each connection is secure and follows the correct wiring codes. Double-check that all connections are tight and properly seated.

**Final Checks:**

Once installed, confirm that the board is properly secured in place and that no wires are pinched or misaligned. Verify all connections for stability and correctness before reassembling the unit.

**Blower, heater, remote receiver, top LED lights Access:**

1. Remove the unit from the cavity and disconnect from power, remove top outer firebox by removing 15 Philip head screws. 5 screws are located on the top of the appliance, 4 screws are located on the rear and 3 screws are located on each side.

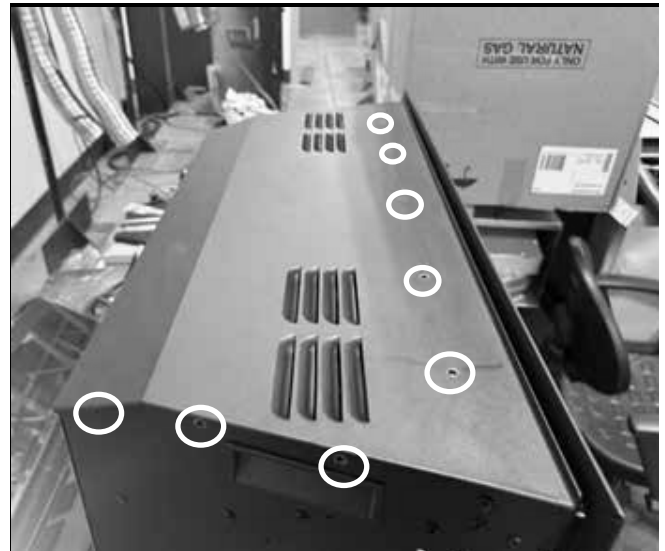

Once all screws have been removed and the outer top shell has been removed, the top of the unit will be exposed as shown below. Access to the heater, blower, upper light and receiver are now accessible to swap out.



**Operation Button Assembly replacement:**

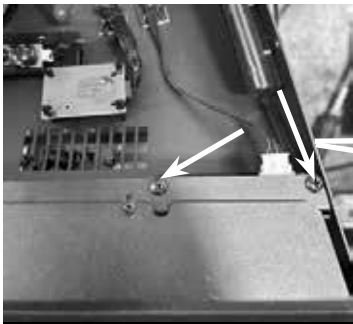

Diagram 1

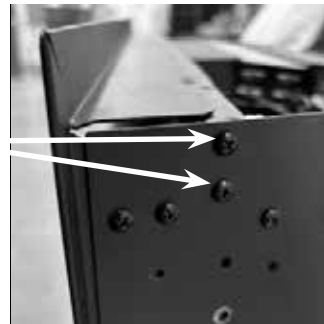

Diagram 2



Diagram 3

**To remove and replace the operation button assembly:**

1. Remove the two Phillips head screws from the top, as shown in Diagram 1, and another two Phillips head screws as shown in Diagram 2.
2. This will release the retainer holding the receiver in place (refer to Diagram 3).
3. Disconnect the Molex connector from the rear of the receiver.
4. Replace the component and follow the steps in reverse to reinstall.

**Top LED light, Heater and blower replacement**

1. With the top of the unit exposed remove the fan mounting bracket by removing 4 Philip head screws on top and 2 Philip head screws on the left and right side as shown below.

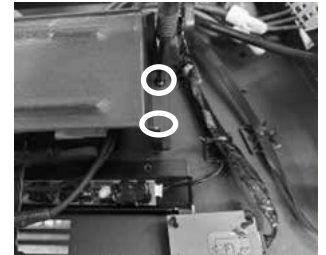
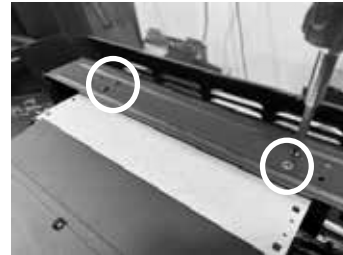

Once the mounting bracket has been removed, remove 3 screws on each side of the heater unit (6 Total) doing so will allow access to the top light and the Molex connector.

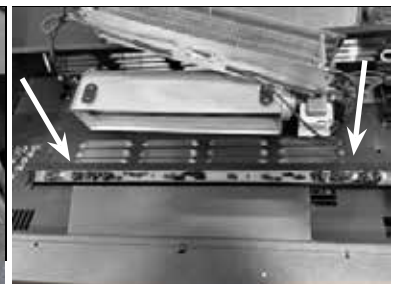
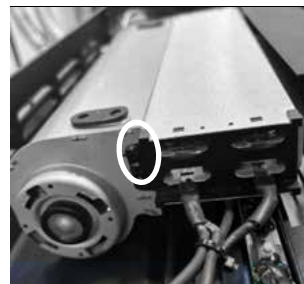

Once the Ember light strip has been removed remove the physical strip from the mounting plate by loosening 2 x nylon Philip head screws as shown below.



To replace the blower or heater unit the above steps will need to be repeated, making sure to disconnect the wiring from the blower or heater unit.

**Blower or Heater Unit Replacement:**

To replace the blower or heater unit, follow the steps outlined above, ensuring that all wiring is properly disconnected before removal.

**Caution:**

- Always ensure the power to the unit is completely disconnected before performing any maintenance to avoid the risk of electrical shock.
- Be mindful of wiring and connectors to prevent damage during removal and reinstallation.
- **Warning:** Improper handling or reconnection of wiring may result in malfunction or pose a fire hazard. Ensure all connections are secure and follow the proper wiring codes before powering the unit back on.

WIRING DIAGRAM

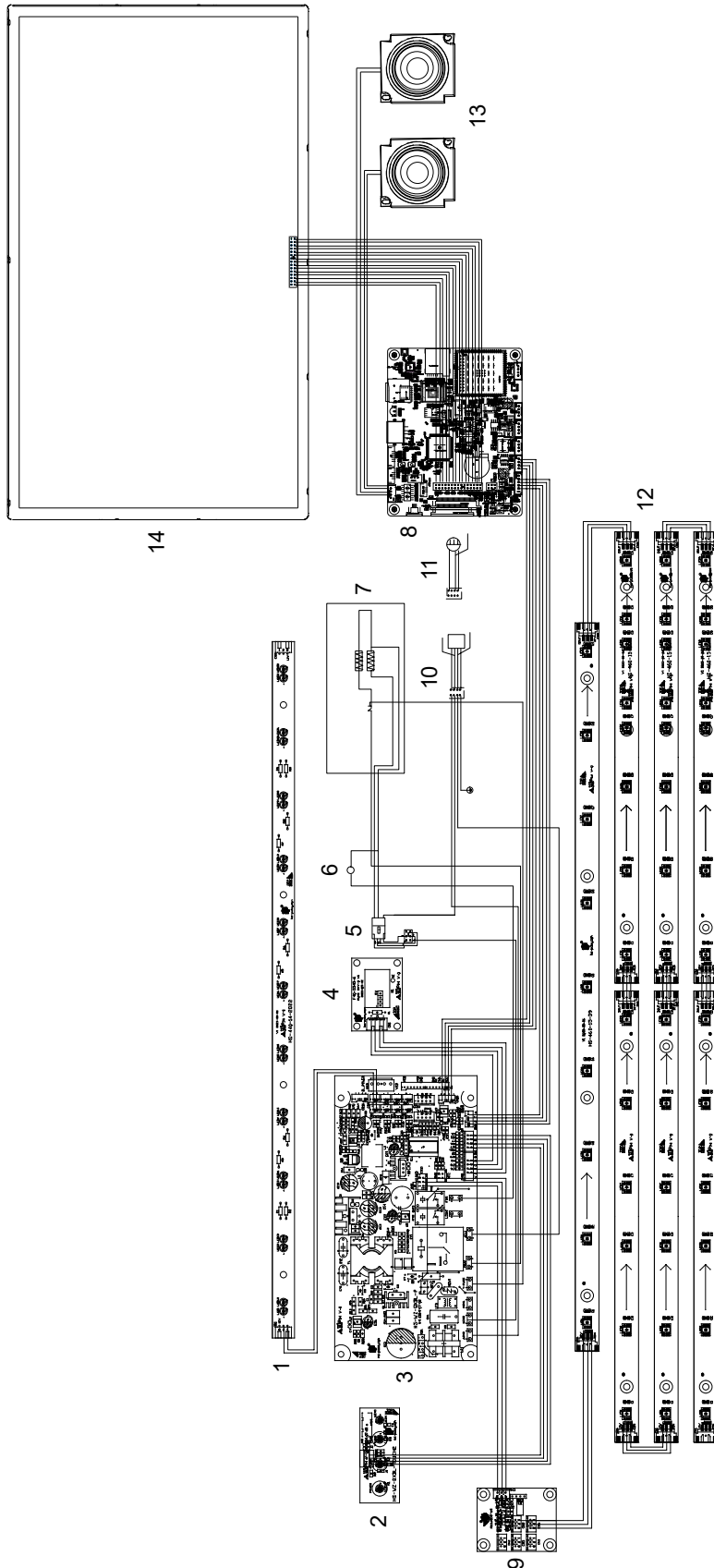

1	LED Top Light
2	Button Assembly
3	Electrical Circuit Board
4	Remote Receiver
5	120/240 VAC Switch
6	Fan
7	Heater
8	Media Board
9	Ember Light Connector
10	Hard Wire Connection
11	Power Cord
12	LED Ember Bed Light
13	Speakers
14	LCD Screen

**SPARE PARTS**

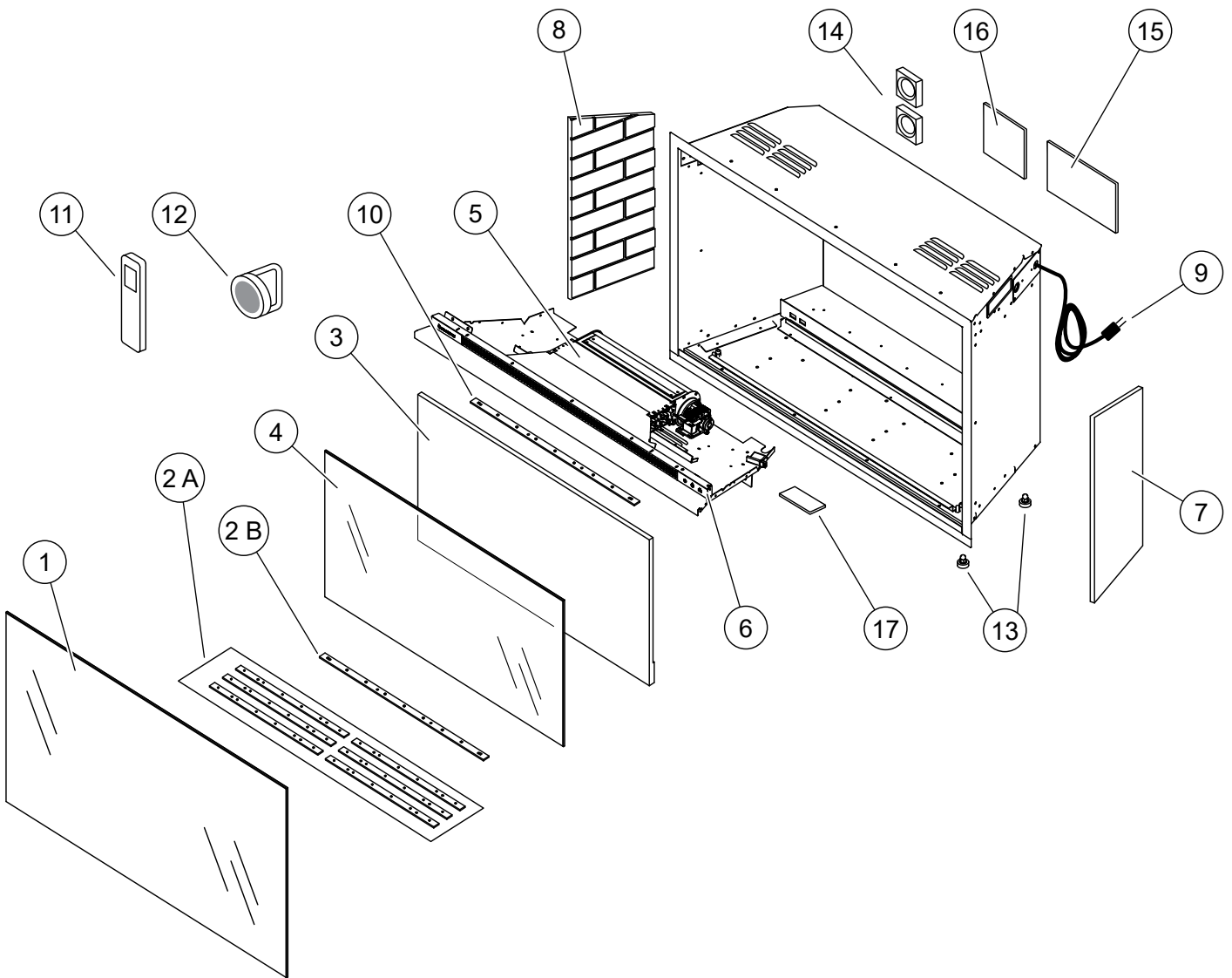

No.	Ei29LCD		
	PART	PART CODE	QTY
1	Front Glass	LCD29-CP2	1
2 A	Ember Bed LED Strips Regular	SCP5R	6
2 B	Ember Bed LED Strips Long	SCP5L	1
3	LCD Screen	LCD29-UCP1	1
4	Thermal Reflective Coated LCD Glass Layer	LCD29-UCP2	1
5	Fan Heating Element Assembly	SCP1	1
6	Touch Panel and Button Assembly	SCP7	1
7	Black Brick Panel RH	LCD29-CP8	1
8	Black Brick Panel LH	LCD29-CP8	1

No.	Ei29LCD		
	PART	PART CODE	QTY
9	Power Cord	SUCP5	1
10	LED Top Light	SCP26	1
11	Remote Control	SCP3	1
12	Glass Placement Suction Cup	SCP10	1
13	Levelling Feet	SCP9	4
14	Speakers	SUCP4	2
15	Electrical Circuit Board	SCP4	1
16	Media Board	SUCP3	1
17	Remote Receiver	SCP11	1

## OPTIONAL FACEPLATES & BACKING PLATE

No.	PART NUMBER	DESCRIPTION
1	281-912	Faceplate Flush 3-Sided Black Ei29
2	281-913	Faceplate Flush 4-Sided Black Ei29
3	281-936	Backing Plate 3-Sided Oversize Black Ei29
4	281-937	Backing Plate Custom 3-Sided Ei29
5	281-938	Backing Plate Custom 4-Sided Ei29

## OPTIONAL PREMIUM & TRADITIONAL SURROUNDS

No.	PART NUMBER	DESCRIPTION
1	311-920	Premium Faceplate Surround Black Ei29
2	311-921	Premium Faceplate Surround Grey Ei29
3	311-922	Premium Faceplate Surround White Ei29
4	311-923	Premium Faceplate Surround Sunset Bronze Ei29
5	311-924	Premium Faceplate Surround Brushed Nickel Ei29
6	311-927	Traditional Faceplate Surround Black
7	311-928	Traditional Faceplate Surround Brushed Antique Copper
8	281-943	Premium Trim Packer

**Note:** Premium & Traditional Surrounds fit on the 3-Sided Faceplate only (281-912).  
A Premium Trim Packer (281-943) must be ordered separately when using either the 311-920/921/922/923/924 Premium Faceplate Surrounds.

## OPTIONAL BRICK PANELS

No.	PART NUMBER	DESCRIPTION
1	281-961	Brown Brick Panel Kit

## OPTIONAL LOG SETS

No.	PART NUMBER	DESCRIPTION
1	281-954	Oak Log Set
2	281-950	Driftwood Log Set
3	281-951	Birch Log Set

**Note:** Must choose from 1 of the 3 log sets as this is required equipment.

## OPTIONAL MOOD LIGHTING KIT

No.	PART NUMBER	DESCRIPTION
1	923-835	Mood Lighting Kit



## INFORMATION REQUIREMENT FOR ELECTRIC LOCAL SPACE HEATERS

<b>Model</b>			<b>Ei29</b>	
			<b>AC120V</b>	<b>AC240V</b>
<b>HEAT OUTPUT</b>	Nominal Heat Output	$P_{nom}$	1400W	2800W
	Minimum Heat Output	$P_{min}$	1400W	2800W
	Maximum Continuous Heat Output	$P_{max, c}$	1400W	2800W

<b>AUXILIARY ELECTRICITY CONSUMPTION</b>	At Nominal Heat Output	$eI_{max}$	41W
	At Minimum Heat Output	$eI_{min}$	40.3W
	In Standby Mode	$eI_{sb}$	1W

### TYPE OF HEAT INPUT, FOR ELECTRIC STORAGE LOCAL SPACE HEATERS ONLY

Manual heat charge control, with integrated thermostat	No
Manual heat charge control with room and/or outdoor temperature feedback	No
Electronic heat charge control with room and/or outdoor temperature feedback	No
Fan assisted heat output	No

### TYPE OF HEAT OUTPUT/ROOM TEMPERATURE CONTROL

Single stage heat output and no room temperature control	No
Two or more manual stages, no room temperature control	No
With mechanic thermostat room temperature control	No
With electronic room temperature control	Yes
Electronic room temperature control plus day timer	No
Electronic room temperature control plus week timer	No

### OTHER CONTROL OPTIONS

Room temperature control, with presence detection	No
Room temperature control, with open window detection	No
With distance control option	No
With adaptive start control	No
With working time limitation	No
With black bulb sensor	No

FPI Fireplace Products International Ltd., 6988 Venture Street, Delta, BC, V4G 1H4, Canada

## LIMITED WARRANTY

FPI Fireplace Products International Ltd. (for Canadian customers) and Fireplace Products US, Inc. (for US customers) (collectively referred to herein as “FPI”) extends this Limited Warranty to the original purchaser of this Appliance provided the product remains in the original place of installation. The items covered by this Limited Warranty and the period of such coverage are set forth in the table below.

An Appliance in this policy is defined as an Electric Fireplace, Electric Insert.

**This Appliance has only been certified and listed for use indoors.**

Some conditions apply (see below).

This Limited Warranty starts on the day the Appliance was purchased.

**The Limited Warranty is not transferable, amendable or negotiable under any circumstances.**

Indoor Electric Products	Component Coverage	Subsidized Labor Coverage*
	1 year	1 year
Front Glass Panel	✓	✓
Display Screen, LCD Screen, LCD Screen Glass Layer Flame Effect Screen	✓	✓
Power Unit, Speakers, Media Board, Circuit Board	✓	✓
Heater Unit	✓	✓
LED Mood Lighting	✓	✓
Fuel Bed	✓	✓
Flame Effect Spindle Flame Effect LED Board	✓	✓
Fuel Effect Spindle Fuel Effect LED Board	✓	✓
Spindle Motor	✓	✓
Power Cable / Plug Kit	✓	✓
Remote Handset	✓	✓
Media (Pebbles, Ember Set, Ember Bed, Brick Panels, Crushed Glass, Ice Set Logs, Driftwood, Birch, Oak Log Sets, Crystals)	✓	✓
Firebox (defect in manufacture)	✓	✓
Faceplates, Backing Plates, Premium & Traditional Surrounds. Premium Trims	✓	✓

**Note:** Warranty coverage noted above may not be applicable as components/options vary based on appliance purchased.

**Conditions:**

Warranty protects against defect in manufacture or FPI factory-assembled components only, unless herein specified otherwise.

**\*This warranty does not cover dealer travel costs, mileage, fuel, tolls for diagnostic or service work. All labor rates paid to authorized dealers are subsidized, pre-determined rates. Dealers may charge you for travel and additional time beyond their subsidy.**

Any part(s) found to be defective during the warranty period as outlined above will be repaired or replaced at FPI’s option through an accredited distributor, dealer or pre-approved and assigned agent provided that the defective part is returned to the distributor, dealer or agent for inspection if requested by FPI. Alternatively, FPI may, at its own discretion, fully discharge all of its obligations under warranty by refunding the verified purchase price of the product to the original purchaser. The

purchase price must be confirmed by the original Bill of Sale.

**IMPORTANT:** A 15 amp, 60Hz 120 Volt circuit is required for installation of this Appliance. A dedicated circuit is not required, but is highly recommended to prevent circuit breaker from tripping or fuse failure. Failure to provide adequate power to this Appliance will void your warranty.

**NOTE: If hard wiring to the Appliance, this must be completed by a qualified electrician. Failure to do so will void your warranty.**

**The authorized selling dealer, or an alternative authorized FPI dealer if pre-approved by FPI, is responsible for all in-field diagnosis and service work related to all warranty claims. FPI is not responsible for results or costs of workmanship of unauthorized FPI dealers or agents in the negligence of their service work.**

At all times, FPI reserves the right to inspect reported in the field/on location complaints of products claimed to be defective before processing or authorizing any claim. Failure to allow this upon request will void the warranty.

All warranty claims must be submitted by the dealer servicing the claim, including a copy of the Bill of Sale (proof of purchase by you). All claims must be complete and provide full details as requested by FPI to receive consideration for evaluation. **Incomplete claims may be rejected.**

**Replacement Appliances to the original purchaser are limited to one per warranty term.**

The Appliance must be installed according to all manufacturers' instructions as per the manual.

All Local and National required codes must be met.

The installer is responsible for ensuring the Appliance is operating as designed at the time of installation.

The original purchaser is responsible for the annual maintenance of the Appliance, as outlined in the owner's manual. As outlined below, the warranty may be voided due to problems caused by a lack of maintenance.

Purchased parts: Repair/replacement parts purchased by the consumer from FPI after the original coverage has expired on the Appliance will carry a **90-day** warranty from the purchase date, valid with a receipt only. Any item shown to be defective will be repaired or replaced at our discretion. No labor coverage is included with these parts.

If freight damage has been found either externally or internally, the dealer must be informed within 3 days. All claims as a result of damage must be submitted by the dealer servicing the claim, including a copy of the Bill of Sale (proof of purchase). All claims must be complete and provide full details as requested by FPI to receive consideration for evaluation. **Incomplete claims may be rejected.**

As this is a **1-year** Limited Warranty, if the Appliance needs to be replaced, the Appliance that was purchased at the time of sale might not be replaced with exactly the same model Appliance. In that case, FPI will replace your Appliance with one that is similar at the time of replacement under the terms of this Limited Lifetime Warranty, but **ONLY** in the event that an item covered by the Limited Lifetime Warranty is found to be defective. Please refer to the table on first page of this warranty for items covered by the Limited Lifetime Warranty. Product changes might be the result of the original Appliance being discontinued, changes in regulatory requirements, product advancements, etc., which are beyond the control of FPI. **This Limited Lifetime Warranty does not cover any installation costs, or costs associated with changes of required clearances for the replacement Appliance, hearth pads, mantles, facing and/or facing materials such as framing, completed walls made of drywall, wood, non-combustible board, tile, brick, stone, marble etc., venting/chimney systems, or components of the chimney system.**

If a suitable replacement is not available, FPI will refund **50%** of the purchase price of the Appliance and any applicable FPI accessories (faceplates, brick panels, media, etc.) purchased at the time of sale. **In no event will FPI refund any portion of the purchase price of, or reimburse costs associated with, any other items, including without limitation, installation of a new unit, changes of required clearances for a new unit, hearth pads, mantles, facing and/or facing materials such as framing, completed walls made of drywall, wood, non-combustible board, tile, brick, stone, marble etc., venting/chimney systems, or components of the chimney system. A copy of the receipt or bill of sale will be necessary to validate the purchase price.**

**Exclusions:**

This Limited Warranty does not extend to paint, rust or corrosion of any kind due to a lack of maintenance, combustion air provision, corrosive chemicals (i.e. chlorine, salt, air, etc.), batteries.

Malfunction, damage or performance-based issues as a result of environmental conditions, location, chemical damages, installation error, an installation by an unqualified installer, operator error, abuse, misuse, lack of regular maintenance and upkeep, acts of God, weather related problems from hurricanes, tornados, earthquakes, floods, lightning strikes/bolts or acts of terrorism or war, which result in malfunction of the Appliance are not covered under the terms of this Limited Warranty.

FPI has no obligation to enhance or modify any Appliance once manufactured (i.e. as products evolve, field modifications or upgrades will not be performed on existing Appliances).

Any Appliance showing signs of neglect or misuse will not be covered under the terms of this warranty policy and may void this warranty, including Appliances with rusted or corroded fireboxes that have not been reported as rusted or corroded within **three (3)** months of purchase.

Appliances which show evidence of being operated while damaged, or with problems known to the purchaser and causing further damages will void this warranty.

Appliances where the serial no. has been altered, deleted, removed or made illegible will void this warranty.

Minor movement, expansion and contraction of the steel is normal and is not covered under the terms of this warranty.

Freight damages for products or parts are not covered under the terms of this warranty.

Products made or provided by other manufacturers and used in conjunction with the FPI Appliance without prior authorization from FPI may void this warranty.

#### **Limitations of Liability:**

The original purchaser's exclusive remedy under this warranty, and FPI's sole obligation under this Limited Warranty, express or implied, in contract or in tort, shall be limited to replacement, repair, or refund, as outlined above. IN NO EVENT WILL FPI BE LIABLE UNDER THIS WARRANTY FOR ANY INCIDENTAL OR CONSEQUENTIAL COMMERCIAL DAMAGES OR DAMAGES TO PROPERTY. TO THE EXTENT PERMITTED BY APPLICABLE LAW, FPI MAKES NO EXPRESS WARRANTIES OTHER THAN THE WARRANTY SPECIFIED HEREIN. THE DURATION OF ANY IMPLIED WARRANTY IS LIMITED TO DURATION OF THE EXPRESSED WARRANTY SPECIFIED ABOVE. IF IMPLIED WARRANTIES CANNOT BE DISCLAIMED, THEN SUCH WARRANTIES ARE LIMITED IN DURATION TO THE DURATION OF THIS WARRANTY.

Some US states do not allow limitations on how long an implied warranty lasts, or allow exclusion or limitation of incidental or consequential damages, so the above limitations or exclusions may not apply to you.

Customers located outside the US should consult their local, provincial or national legal codes for additional terms which may apply to this warranty.

#### **How to Obtain Warranty Service:**

Customers should contact the authorized selling dealer to obtain warranty service. In the event the authorized selling dealer is unable to provide warranty service, please contact FPI by mail at the address listed below. Please include a brief description of the problem and your address, email and telephone contact information. A representative will contact you to make arrangements for an inspection and/or warranty service.

##### Canadian Warrantor:

**FPI Fireplace Products International Ltd.**  
6988 Venture St.  
Delta, British Columbia  
Canada, V4G 1H4

##### US Warrantor:

**Fireplace Products U.S., Inc.**  
PO Box 2189 PMB 125  
Blaine, WA  
United States, 98231

Or contact the Regency Customer Care Centre at 1-800-442-7432 (phone) /604-946-4349 (fax) /customerservice@regency-fire.com (e-mail)

#### **Product Registration and Customer Support:**

Thank you for choosing a Regency Fireplace. Regency strives to be a world leader in the design, manufacture, and marketing of hearth products. To provide the best support for your product, we request that you complete a product registration form at <http://www.regency-fire.com/Customer-Care/Warranty-Registration.aspx> within **ninety (90)** days of purchase.



### Product Registration and Customer Support:

Thank you for choosing a Regency Fireplace. Regency strives to be a world leader in the design, manufacture, and marketing of hearth products. To provide the best support for your product, we request that you complete a product registration form found on our Web Site under Customer Care within ninety (90) days of purchase.

For purchases made in **CANADA or the UNITED STATES:**

<http://www.regency-fire.com/Customer-Care/Warranty-Registration.aspx>

For purchases made in **AUSTRALIA:**

<http://www.regency-fire.com.au/Customer-Care/Warranty-Registration.aspx>

You may also complete the warranty registration form below to register your Regency Fireplace Product and mail and/or fax it back to us, and we will register the warranty for you. It is important you provide us with all the information below in order for us to serve you better.

### Warranty Registration Form (or Register online immediately at the above Web Site):

<b>Warranty Details</b>	
Serial Number (required):	
Purchase Date (required) (mm/dd/yyyy):	
<b>Product Details</b>	
Product Model (required):	
<b>Dealer Details</b>	
Dealer Name (required):	
Dealer Address:	
Dealer Phone #:	
Installer:	
Date Installed (mm/dd/yyyy):	
<b>Your Contact Details (required)</b>	
Name:	
Address:	
Phone:	
Email:	

For purchases made in **CANADA:**

**FPI Fireplace Products International Ltd.**  
6988 Venture St.  
Delta, British Columbia  
Canada, V4G 1H4

Phone: 604-946-5155  
Fax: 1-866-393-2806

For purchases made in the **UNITED STATES:**

**Fireplace Products US, Inc.**  
PO Box 2189 PMB 125  
Blaine, WA  
United States, 98231

Phone: 604-946-5155  
Fax: 1-866-393-2806

For purchases made in **AUSTRALIA:**

**Fireplace Products Australia Pty Ltd**  
99 Colemans Road  
Dandenong South, Vic. 3175  
Australia

Phone: +61 3 9799 7277  
Fax: +61 3 9799 7822

For fireplace care and tips and answers to most common questions please visit our Customer Care section on our Web Site. Please feel free to contact your selling dealer if you have any questions about your Regency product.

## RECYCLING

**PRODUCT LIFE CYCLE:**

By recycling your used appliances, you divert waste from your local landfills and help the environment. You also reduce the need for raw materials to manufacture new products. Contact your local municipality for appliance recycling services, local recycling programs, or appliance removal services to ensure your Regency appliance components, and packaging are properly recycled.



***Installer: Please complete the following information***

Dealer Name & Address: \_\_\_\_\_

\_\_\_\_\_

Installer: \_\_\_\_\_

Phone #: \_\_\_\_\_

Date Installed: \_\_\_\_\_

Serial #: \_\_\_\_\_