

# WATERFORD

## Emerald Vented Gas Heater

SIT 820 NOVA mV

(B-Vent)

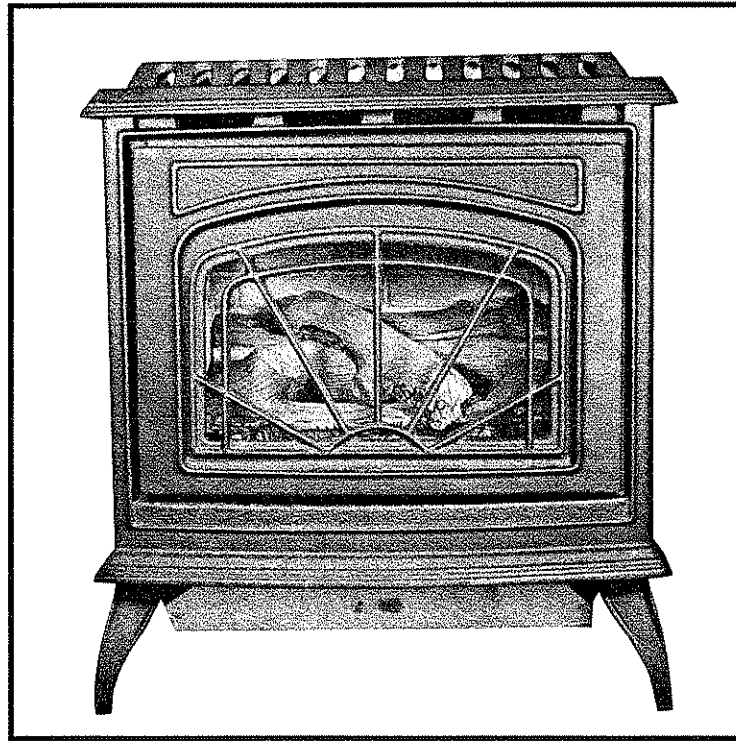

**WARNING:** If the information in this manual is not followed exactly, a fire or explosion may result causing property damage, personal injury or loss of life.

**– FOR YOUR SAFETY**

Do not store or use gasoline or other flammable vapors and liquids in the vicinity of this or any other appliance.

**– FOR YOUR SAFETY: WHAT TO DO IF YOU SMELL GAS**

- Do not try to light any appliance.
- Open windows.
- Extinguish any open flame.
- Do not touch any electrical switch; do not use any phone in your building.
- Immediately call your gas supplier from a neighbor's phone.  
Follow the gas supplier's instructions.
- If you cannot reach your gas supplier, call the fire department.

**– Installation and service must be performed by a qualified gas installer, service agency, or the gas supplier.**

## TABLE OF CONTENTS

INTRODUCTION.....	3
INSTALLATION .....	4
Clearances .....	4
Venting .....	5
Test for Flue Spillage.....	5
Assembly.....	6
Connecting to a Gas Supply .....	7
Connecting the Wiring.....	8
Air Shutter Adjustment .....	9
Monitoring the Gas Flame .....	9
OPERATION .....	10
How to Light the Fire .....	10
How to Turn Off the Fire .....	10
Lighting Instructions .....	11
MAINTENANCE .....	12
Removing the Glass .....	12
Cleaning the Glass .....	12
Replacing the Gasket .....	12
Inspecting the Venting .....	12
Cleaning the Logset and Firebox .....	12-13
PARTS LIST & DRAWING .....	14-15
APPENDIX A: FUEL CONVERSION .....	16-17
APPENDIX B: BLOWER INSTALLATION .....	18-19
APPENDIX C: ALTITUDE DE-RATING .....	20-21
APPENDIX D: SPECIFICATIONS.....	22



# WATERFORD

*Fine Porcelain Enamel, Cast Iron Stoves from Ireland*

Manufactured by Waterford Irish Stoves, Inc.  
West Lebanon, New Hampshire

Tested by Warnock Hersey  
8431 Murphy Drive  
Middleton, WI 53562

WARNOCK HERSEY



---

# Introduction

The Waterford Emerald Vented Gas Heater is a listed gas-fired vented room heater tested by Warnock Hersey to ANSI standard Z21.11.1-1993, CAN 1-2.1-M89, and CAN/CGA-2.17-M91.

The installation of the Emerald Vented Gas Heater must conform with local codes, or in the absence of local codes, with National Fuel Gas Code, ANSI Z223.1 — latest edition and CAN 1-B1-149.1 and .2 Installation Code. It is not for use in mobile homes.

**CAUTION:** This appliance must be vented to the outside.

Installation and repair of the Emerald Vented Gas Heater should be done by a qualified service person. The appliance should be inspected before use and at least annually by a qualified service person. More frequent cleaning may be required due to excessive lint from carpeting, bedding material, etc. It is imperative that control compartments, burners, and circulating air passageways of the Emerald be kept clean. When operating your Waterford Emerald Gas Heater, respect basic safety standards. Read these instructions carefully before you attempt to operate the heater. Failure to do so may result in damage to property or personal injury and may void the product warranty.

Consult with your local building code agency and insurance representative before you begin your installation to ensure compliance with local codes, including the need for permits and follow-up inspections.

The Emerald is shipped complete with the log set packed in the firebox. Do not use a mechanical lift to move the appliance as it will crush or damage the gas pipe connection and/or the bottom heat shield. If the optional fan has also been purchased, it will have been packaged separately.

Several issues must be addressed when selecting a suitable location for your Emerald Gas Heater. Observing required clearances to combustible materials, the proximity to a safe chimney or venting system, and the accessibility of the gas and electrical supply must all be considered. In addition, selecting a location that takes advantage of the building's natural air flow is also desirable to maximize the heating effectiveness of the heater. In many cases, this is a central location within the building.

Adequate combustion and ventilation air must be provided.

# INSTALLATION

Due to high temperatures, the Emerald Vented Gas Heater should be located out of traffic and away from furniture and draperies.

Children and adults should be alerted to the hazards of high surface temperatures and should stay away to avoid burns or clothing ignition.

Young children should be carefully supervised when they are in the same room as the Emerald Vented Gas Heater.

Clothing or other flammable materials should not be placed on or near the Emerald Vented Gas Heater.

## CLEARANCES

The following clearances to combustibles must be observed:

Unit to left sidewall	6" (150 mm)
Unit to right sidewall	10" (255 mm)
Rear of unit to back wall	5" (125 mm)
Vertical vent pipe to back wall	2" (50 mm)
Unit corner to walls	2" (50 mm)
Unit to alcove ceiling	18" (460 mm)
Maximum alcove depth	24" (610 mm)

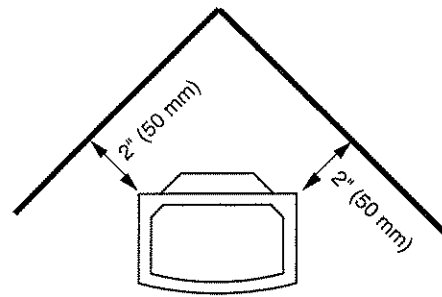

Clearance from corner of unit to walls.

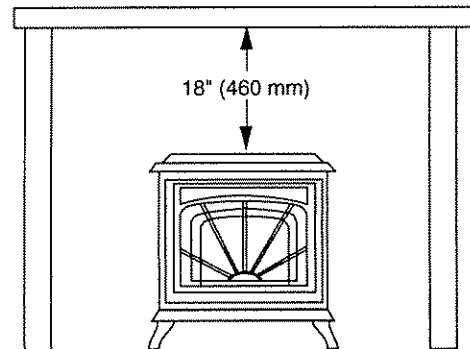

Clearance to alcove ceiling.

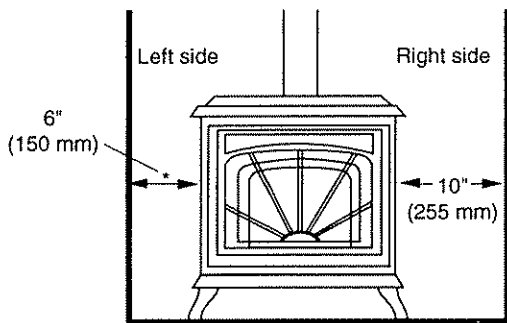

Left and right sidewall clearances

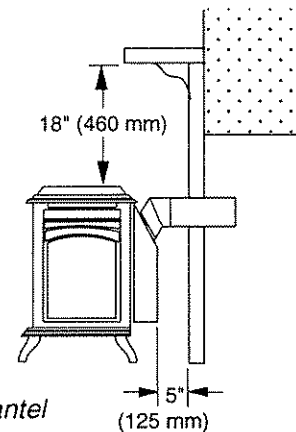

Clearances to mantel and back wall

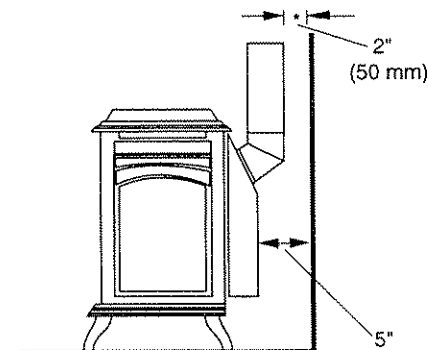

Clearance to back wall

In addition to these clearances, adequate accessibility clearance for servicing and proper operation must be maintained.

Do not in any way obstruct the combustion air inlets that are located under the heater.

If this appliance is installed directly on carpeting, tile or other combustible material other than wood flooring the appliance shall be installed on a metal or wood panel extending at least the full width and depth of the appliance.

## VENTING

### Use Only Approved Venting

The Emerald gas heater is tested and listed for connection to a 4" (100 mm) listed Class B venting system.

If the unit is installed to vent through an approved masonry chimney or a factory-built chimney system, an approved Class B chimney liner must be used.

Observe local codes when venting the Emerald. If no local codes exist, follow ANSI Z223.1 and CAN1-B149 installation codes.

Do not connect the venting to the flue of a chimney that serves a separate solid-fuel burning appliance.

The venting manufacturer's installation instructions must be followed exactly.

**IMPORTANT:** Because of the high efficiency and low flue gas temperatures of this appliance, it is important that it be connected to a well-sealed and efficient venting system which is capable of registering a negative pressure while the stove is in operation.

The most efficient venting systems are those that have a minimum number of bends and minimal horizontal runs.

The Emerald gas heater is equipped with a thermally activated vent safety switch which will shut down the main burner if the heater is not properly venting. The safety switch will automatically reset after the heater has cooled down.

The switch will continue to cycle off and on until the venting problem is corrected. If you are unable to correct the venting problem, seek expert advice from your Waterford dealer or installer.

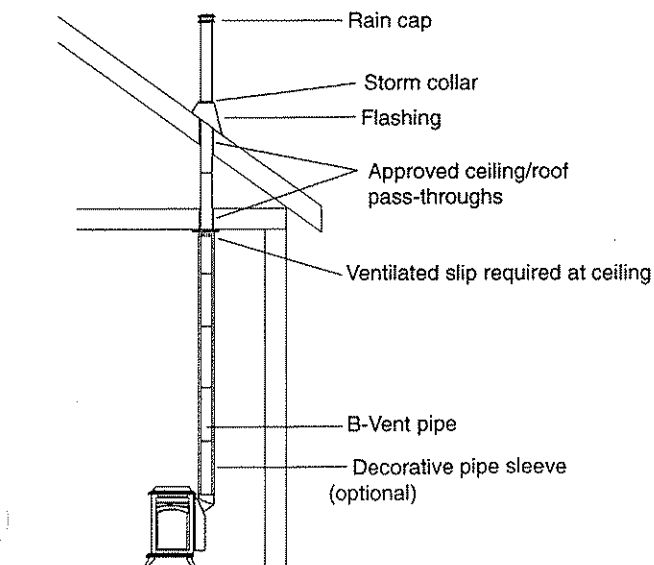

Top exit venting through ceiling and roof

## DO NOT DISCONNECT OR BYPASS THE VENT SAFETY SWITCH.

**WARNING:** Operation of this heater when not connected to a properly installed and maintained venting system or tampering with the vent safety shutoff system can result in carbon monoxide (CO) poisoning and possible death.

The Emerald gas heater is equipped with its own internal draft hood so no additional external draft hood is required. The heater should be installed so that the draft hood is in the same atmospheric pressure zone as the air inlets to the heater.

**NOTE:** The first section of venting installed on the Emerald must be a 45° elbow.

## TEST FOR FLUE SPILLAGE

A spillage test should always be made at the completion of the installation.

1. Start all exhaust fans in the home and then close all doors and windows in the room containing the heater.

2. Light the heater and allow it to run for 5 minutes on the high output setting. If the optional convection air blower is installed, it should be turned off for the test.

3. Place a source of smoke (such as a match or a cigarette) near the center of the slot in the upper portion of the rear heat shield.

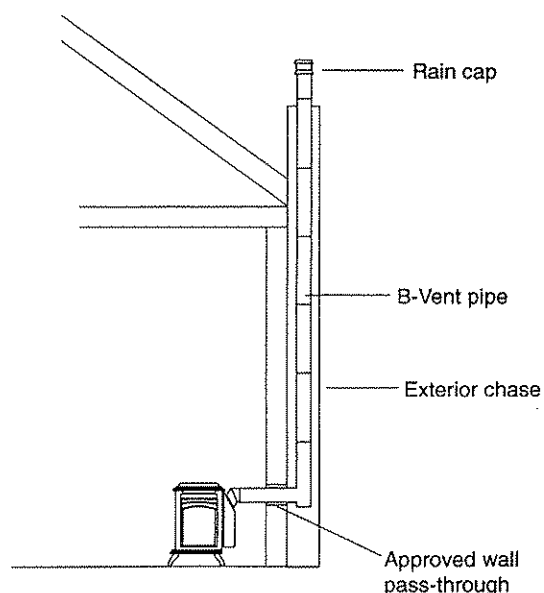
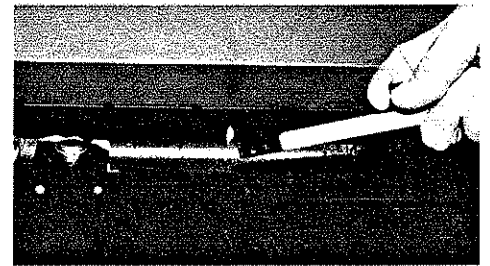

Rear exit venting to an outside chase

The smoke should be drawn into the slot. If it is not, let the heater run for 5 more minutes and repeat the test.

4. If the smoke is not drawn into the slot, turn off the heater and determine the cause of the lack of draft. If necessary, seek expert advice.

For sites with swirling or turbulent wind conditions, a wind cap may solve the problem.

## ASSEMBLY

The Emerald needs only to have the top log installed before it is complete, and to do this it is necessary to open the front door.

### *Opening the Front Door*

Open the right side door to expose the controls and the heat shield just inside the door.

Above and to the left of the control module is a cut-out in the heat shield through which can be seen a wing nut threaded on to a stud attached to the front door.

Loosen this nut by turning it counterclockwise.

*The wing nut that holds the front door is accessible through the cut-out in the side heat shield.*

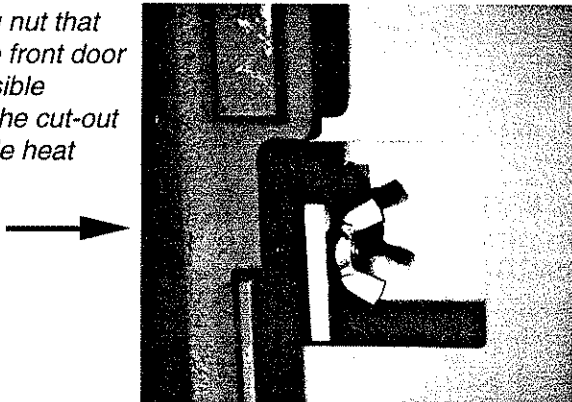

After the nut has been removed, open the front door and remove the individually wrapped top log and carefully unwrap it.

### *Installing the Top Log*

Lay the top log across both the rear and front logs, matching the two receptacles in its bottom to the corresponding posts in the front and rear logs.



*Keys on the bottom of the top log match corresponding posts on the rear and front logs for a sure fit.*

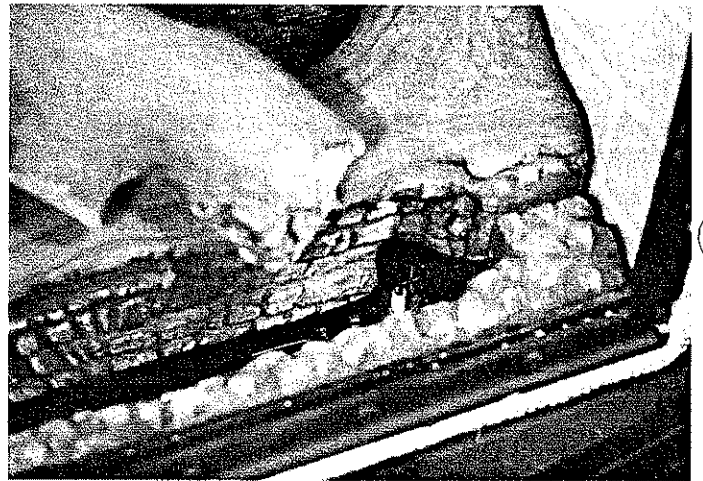

*The pilot may be viewed through a space designed into the front log and the ember strip.*

### *Securing the Front Door*

Close the door. Thread the wing nut onto the end of the stud from which it was removed. Tighten the nut until it is fully tightened.

### *Install the Leg Levelling Bolts*

Four bolts that thread on to the Emerald's legs are packaged separately in a plastic bag. Install one bolt on each of the legs by threading it up through the tapped hole on the bottom of the leg. Adjust the bolts once the installation is complete so that the Emerald is level and stable.

## CONNECTING THE HEATER TO A GAS SUPPLY

### *Burn Only the Fuel for which the Heater is Equipped*

The Emerald Vented may be shipped from the factory equipped to burn either natural gas or propane. The listing plate affixed to the back of the heater will state the fuel for which it is factory-equipped.

### *Making The Connection*

The gas inlet is located on the gas control valve that is on the lower right side of the heater near the right rear leg. The inlet fitting is a 1/2" male flare.

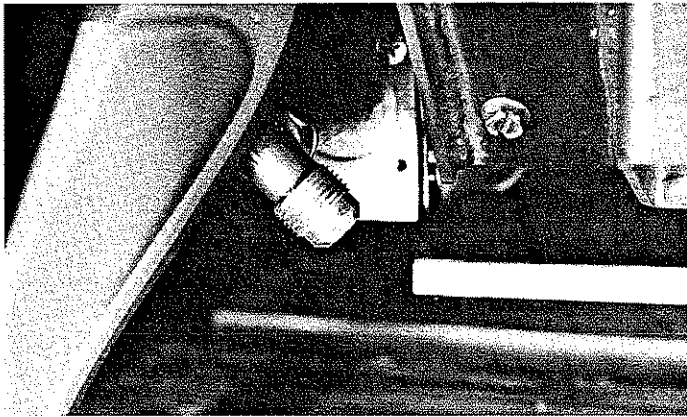

The inlet fitting is a 1/2" male flare.

A separate gas shut-off valve and a 1/8" IPS plugged tapping should be installed immediately upstream of the connection to the appliance.

The Emerald Vented Gas Heater must be disconnected from the gas supply piping during any pressure testing of that system at pressures in excess of 1/2 psig (3.5 kPa).

The Emerald gas control valve must be in the OFF position during any pressure testing of the gas supply system at pressures equal to or less than 1/2 psig (3.5 kPa).

**WARNING: To avoid pipe compounds from entering into the gas train, do not apply compounds to the first two threads at the tip of the gas connection.**

**CAUTION: TEST ALL JOINTS FOR LEAKS BEFORE OPERATING**

### *Gas Pressure Requirements*

Correct gas pressure and the use of a properly sized gas supply line is essential for the safe and efficient performance of this appliance. Make sure that the plumber or gas supplier checks the gas supply line and gas pressure at installation.

When the inlet pressure is being checked, it is important that the unit be turned on and that all other gas appliances in the house are operating.

NOTE: Improper gas pressure can affect heater performance, flame color, or cause pilot outage.

#### **Natural Gas:**

Maximum inlet pressure 11" w.c. (2.74 kPa)

Minimum inlet pressure 5.0" w.c. (1.25 kPa)

Gas manifold pressure 3.5" w.c. (0.87 kPa)

#### **LPG Gas:**

Maximum inlet pressure 13" w.c. (3.24 kPa)

Minimum inlet pressure 11" w.c. (2.74 kPa)

Gas manifold pressure 10.0" w.c. (2.49 kPa)

**DO NOT USE THIS HEATER IF ANY PART HAS BEEN UNDER WATER OR EXPOSED TO MOISTURE CORROSION. IMMEDIATELY CALL A QUALIFIED SERVICE TECHNICIAN TO INSPECT THE HEATER AND REPLACE ANY PART OF THE CONTROL SYSTEM AND ANY GAS CONTROL WHICH HAS BEEN UNDER WATER.**

RECOMMENDED GAS PIPE DIAMETER				
Pipe Length (Feet)	Schedule 40 Pipe Inside Diameter		Tubing, Type L Outside Diameter	
	N.G.	L.P.	N.G.	L.P.
0-10	1/2" 1.3 cm	3/8" 1.0 cm	1/2" 1.3 cm	3/8" 1.0 cm
10-40	1/2" 1.3 cm	1/2" 1.3 cm	5/8" 1.6 cm	1/2" 1.3 cm
40-100	1/2" 1.3 cm	1/2" 1.3 cm	3/4" 1.6 cm	1/2" 1.3 cm
100-150	3/4" 2.0 cm	1/2" 1.3 cm	7/8" 2.3 cm	3/4" 2.0 cm

NOTE: NEVER USE PLASTIC PIPE. CHECK TO CONFIRM WHETHER YOUR LOCAL CODES ALLOW COPPER TUBING OR GALVANIZED PIPE.

## CONNECTING THE WIRING

The Emerald Vented Gas Heater must be installed in accordance with local codes or, in the absence of local codes, with the most recent edition of the National Electrical Code ANSI/NFPA 70, or the current Canadian Electrical Code C22.1.

NOTE: This heater **does not** require a 120 VAC supply for operation. See Appendix B of this manual for electrical requirements if the optional Convection Blower is installed.

CAUTION: LABEL ALL WIRES PRIOR TO DISCONNECTION WHEN SERVICING CONTROLS. WIRING ERRORS CAN CAUSE IMPROPER AND DANGEROUS OPERATION. VERIFY PROPER OPERATION AFTER SERVICING.

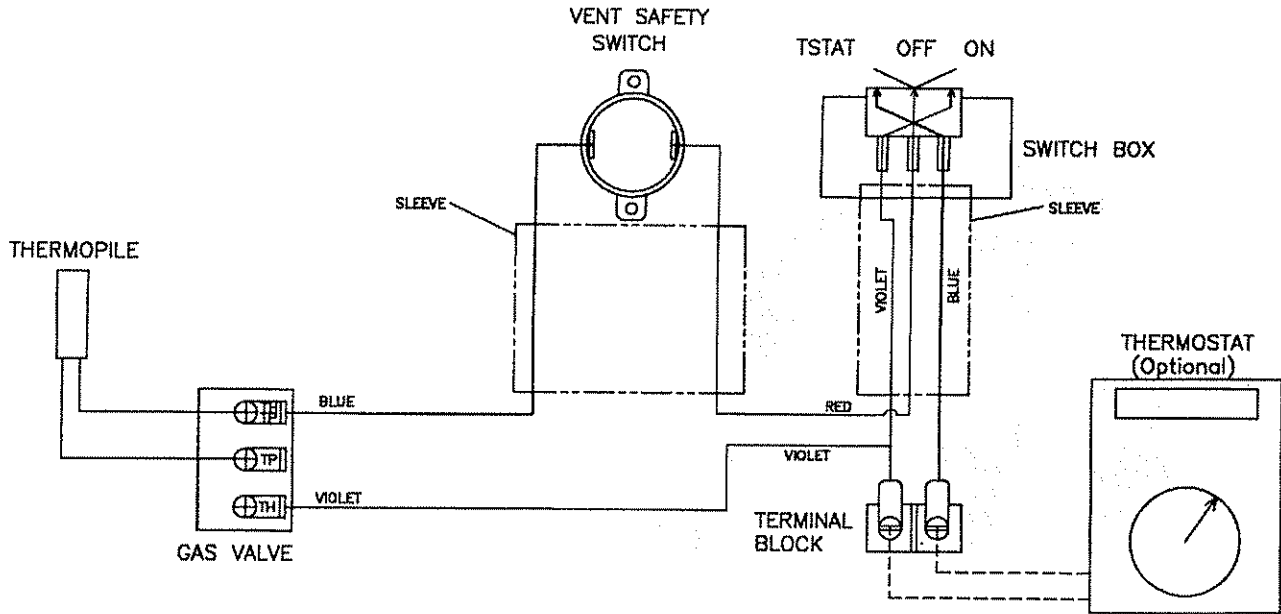

*Emerald Direct Vent Low Voltage Wiring Diagram*

### *Wire Connections for the Optional Thermostat*

If the optional thermostat is being used, connect the wires to the terminal block located on the lower right rear corner of the heater. (See photo at right.)

The wires may go to either terminal. The gauge of the wire should match the wire length required by the installation according to the chart below.

Maximum Length	Wire Gauge
100'	14
60'	16
40'	18
25'	20
15'	22

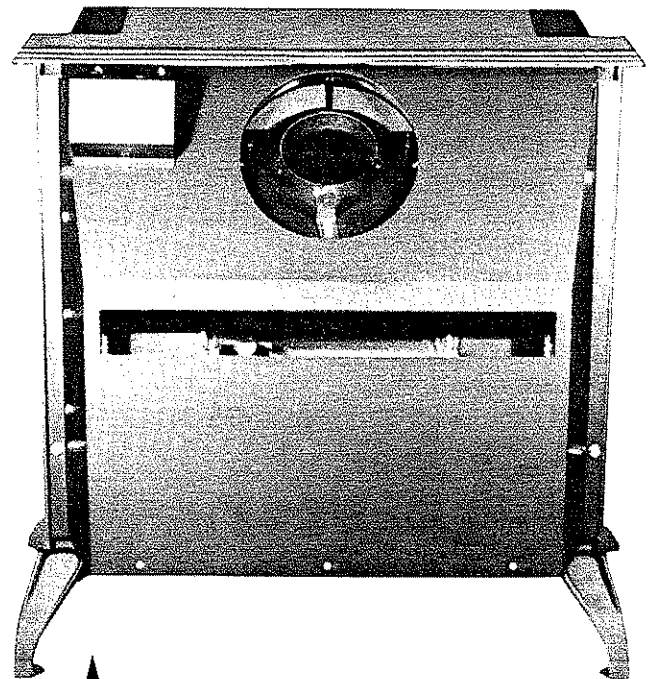

The terminal block for the optional thermostat is located in the lower rear corner nearest the controls.



## AIR SHUTTER ADJUSTMENT

The final step of the installation is to check the flame pattern. The flames should not extend over the rear baffle and excessive soot should not be present. The flames should approximate the pattern seen in the illustration in the right column.

Start the heater according to the directions on page 10 and allow the heater to burn for approximately 15 minutes. The flames will increase in length and become more yellow in color as the Emerald heats up.

*If the flames do not resemble the description above and the illustration in the right column, the air shutter may be adjusted.*

1. Turn the heater off and allow it to cool sufficiently so that it may be touched safely.

2. Open the front door (see instructions, page 6).

3. Carefully remove the top log, the front log, and the ember strip.

4. Using a long screwdriver, reach down and loosen the locking screw on the air shutter.

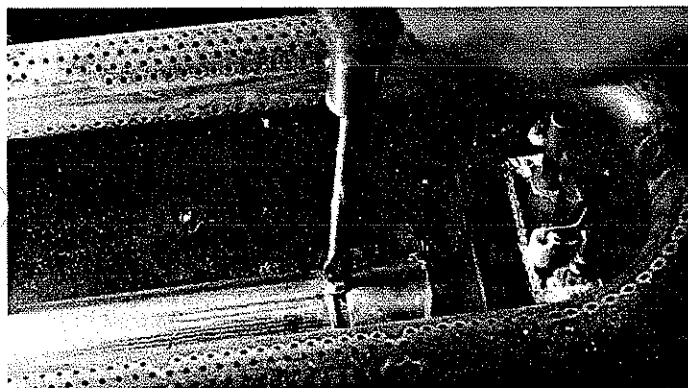

5. Carefully replace the top log, the front log, and the ember strip.

6. Shut the front door and secure it following the directions on page 6.

7. Re-start the heater, and let it burn for approximately 15 minutes.

8. Insert a long-handled Allen wrench into the adjusting key on the right side of the heater.

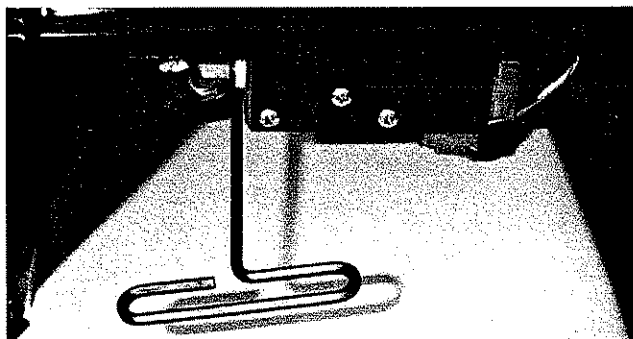

Use a 3/16" Allen wrench.

9. Turn the adjusting mechanism until the desired flame presentation is achieved. Turning the adjuster clockwise will increase the flame volume; turning counterclockwise will diminish the volume. The rear flame must not extend beyond the flame baffle and no soot should be forming on any surface.

10. When the flame pattern is satisfactory, turn the heater off and allow it to cool until it may be touched safely.

11. Open the front door.

12. Carefully remove the top log, the front log, and the ember strip.

13. Reach down with the long screwdriver and tighten the locking screw on the air shutter.

14. Carefully replace the top log, the front log, and the ember strip.

15. Shut the front door and secure it following the directions on page 6.

## MONITORING THE GAS FLAME

Periodically, the flames of the Emerald Vented Gas Heater should be checked while it is operation. The flames should not extend over the flame baffle, and excessive soot should not be present. If you find the flames to be other than that described here, do not operate the heater. Consult a qualified service person or your Waterford dealer for advice.

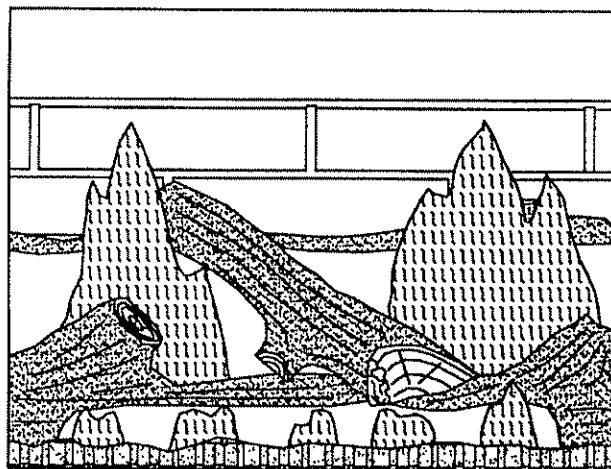

*The Emerald flame pattern will resemble this when the unit is burning properly.*

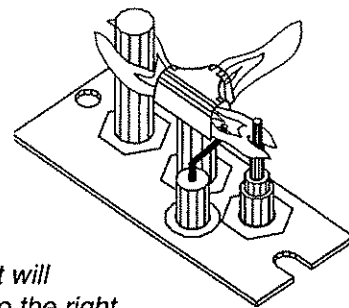

*The properly-burning pilot will resemble the illustration to the right.*

# Operation

## HOW TO LIGHT THE FIRE

**WARNING:** Do not abuse the Emerald's glass by striking, slamming, or similar trauma. Do not operate the Emerald Vented Gas Heater with the glass panel removed, cracked or broken. Use only glass supplied by Waterford and approved for use with this heater. Do not use substitute materials. Replacement of the panel should be done by a licensed or qualified service person.

**NOTE:** An odor resulting from the initial heating of new materials in your heater is not unusual during the first fire, and in most cases will disappear after an hour or two.

1. STOP! Read the safety information on the top of the panel on page 11.
2. If using the optional thermostat, set it to the lowest setting.
3. Turn off electric power to the appliance if optional fan is used.
4. Turn the ON-OFF/THERMOSTAT switch to the OFF position.

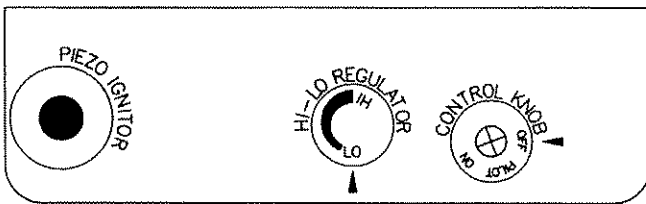

5. Push in the gas control knob slightly and turn it clockwise to "OFF." **NOTE:** The knob cannot be turned from "PILOT" to "OFF" unless it is pushed in slightly. Do not force it.
6. Wait five (5) minutes to clear out any gas. If you then smell gas, STOP! Follow "B" in the safety information on the top of page 11. If you don't smell gas, go to the next step.
7. Set the High-Low Regulator to High by turning it fully counterclockwise.
8. Press in the gas control knob slightly and turn counterclockwise to "PILOT."
9. Find the pilot by looking through the front door. The pilot is located at the right end of the firebox below the front log. A viewing space is provided between the front log and the ember strip, making it possible to observe the pilot.

10. Push the control knob fully down and hold. Immediately push the red piezo ignitor button to light the pilot. It is normal to have to push the red button several times before the pilot ignites. Continue to hold the control knob in for about one (1) minute after the pilot is lit. Release the knob and it will pop back up. Pilot should remain lit. If it goes out, repeat steps 5 through 9.

- If the knob does not pop up when released, stop and immediately call your service technician or gas supplier.

- If the pilot will not stay lit after several tries, turn the gas control knob to "OFF" and call your service technician or gas supplier.

11. Turn the gas control knob counterclockwise to "ON."

12. Place the ON-OFF/THERMOSTAT switch in the ON position, or in the THERMOSTAT position if the optional thermostat is used.

13. Turn on the electric power to the heater if the optional fan is used.

14. Set the optional thermostat to the desired room temperature.

15. Set the High-Low Regulator to desired setting: turn fully counterclockwise for High and fully clockwise for Low.

## HOW TO TURN OFF THE FIRE

1. If using the optional thermostat, set it to the lowest position.
2. Turn off the electric power to the appliance if the optional fan is used.
3. Turn the ON-OFF/THERMOSTAT switch to the OFF position.
4. Push in the gas control knob slightly and turn it clockwise to "OFF."

**NOTE:** The knob cannot be turned from "PILOT" to "OFF" unless it is pushed in slightly. Do not force it.

## FOR YOUR SAFETY READ BEFORE OPERATING

**WARNING: If you do not follow these instructions exactly, a fire or explosion may result causing property damage, personal injury, or loss of life.**

A. This appliance has a pilot. When lighting the pilot, follow these instructions exactly.

B. **BEFORE OPERATING** smell all around the appliance area for gas. Be sure to smell next to the floor because some gas is heavier than air and will settle on the floor.

### WHAT TO DO IF YOU SMELL GAS

- Do not try to light any gas appliance.
- Do not touch any electric switch; do not use any phone in your building.
- Immediately call your gas supplier from a neighbor's phone.

Follow the gas supplier's instructions.

•If you cannot reach your gas supplier. Call the fire department.

C. Use only your hand to push in or turn the gas control knob. Never use tools. If the knob will not push in or turn by hand, don't try to repair it. Call a qualified service technician. Force or attempted repair may result in a fire or explosion.

D. Do not use this appliance if any part has been under water. Immediately call a qualified service technician to inspect the appliance and to replace any part of the control system and any gas control that has been under water.

## LIGHTING INSTRUCTIONS

1. STOP! Read the safety information on the panel above.
2. If using optional thermostat, set thermostat to lowest setting.

3. Turn off electric power to the appliance if optional fan is used.



4. Turn ON-OFF/THERMOSTAT switch to OFF position.
5. Push in gas control knob slightly and turn clockwise to "OFF."

NOTE: Knob cannot be turned from "PILOT" to "OFF" unless knob is pushed in slightly. Do not force.

6. Wait five (5) minutes to clear out any gas. If you then smell gas, STOP! Follow "B" in the safety information above on this label. If you don't smell gas, go to the next step.

7. Set High-Low Regulator to HIGH by turning fully counterclockwise.

8. Press in the gas control knob slightly and turn it counterclockwise to "PILOT."

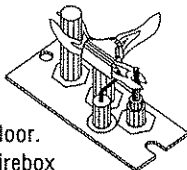

9. Find pilot by looking through the front door. The pilot is located at the right end of the firebox

below the middle log. A cutout is provided in the middle log to make it easier to observe the pilot.

10. Push the control knob fully down and hold. Immediately push the red piezo ignitor button to light the pilot. It is normal to have to push the red button several times before the pilot ignites. Continue to hold the control knob in for about one (1) minute after the pilot is lit. Release knob and it will pop back up. Pilot should remain lit. If it goes out, repeat steps 5 through 9.

•If knob does not pop up when released, stop and immediately call your service technician or gas supplier.

•If the pilot will not stay lit after several tries, turn the gas control knob to "OFF" and call your service technician or gas supplier.

11. Turn gas control knob counterclockwise to "ON."

12. Place the ON-OFF/THERMOSTAT switch in ON position or in the THERMOSTAT position if the optional thermostat is used.

13. Turn on electric power to appliance if optional fan is used.

14. Set the optional thermostat to desired room temperature.

15. Set the High-Low Regulator to desired setting: turn fully counterclockwise for High and fully clockwise for Low.

## TO TURN OFF GAS TO APPLIANCE

1. If using optional thermostat, set thermostat to the lowest position.

2. Turn off electric power to the appliance if optional fan is used.

3. Turn ON-OFF/THERMOSTAT switch to OFF position.

4. Push in gas control knob slightly and turn clockwise to "OFF."

NOTE: Knob cannot be turned from "PILOT" to "OFF" unless knob is pushed in slightly. Do not force.

**CAUTION: HOT WHILE IN OPERATION. DO NOT TOUCH. KEEP CHILDREN, CLOTHING, FURNITURE, GASOLINE, OR LIQUIDS WITH FLAMMABLE VAPORS AWAY.**

**ATTENTION: CHAUD PENDANT LE FONCTIONNEMENT, NE TOUCHEZ PAS. TENIR ÉLOIGNÉS LES ENFANTS, LE VÊTEMENTS ET LES MEUBLES.**

Refer to label on rear of appliance for venting information. Keep burner and control compartment clean. Refer to owner's manual accompanying this appliance. Maintenir propres le brûleur et le compartiment de commande. Voir les instructions relatives à l'installation et au fonctionnement qui accompagnent le radiateur.

Distributed by Waterford Irish Stoves, Inc.  
16 Airpark Road, Suite 3  
W. Lebanon, New Hampshire 03784.  
TEL: 1-603-298-5030; FAX: 1-603-298-7885.  
**DO NOT REMOVE OR COVER THIS LABEL**

# Maintenance

The appliance area must be kept clear and free from combustible materials, gasoline, and other flammable vapors and liquids.

The flow of combustion and ventilation air must not be obstructed.

A qualified service person recommended by your Waterford dealer should conduct an annual inspection and maintenance of your Emerald, its venting, and the installation to keep it running safely and efficiently. The following procedures should be performed only by a qualified service person. The gas supply should be turned off whenever a maintenance procedure is performed.

## REMOVING THE GLASS FOR REPLACEMENT

1. Open the front door as described in the section on this page entitled *Cleaning the Log Set and Firebox*.
2. Remove the six screws that secure the retainers holding the glass in place.
3. Remove the glass.
4. Place the replacement glass in position.
5. Install two bottom retainers and turn the screws in just enough to support the glass.
6. Install the other retainers with their respective screws.
7. Tighten the screws alternately. Do not over-tighten to avoid damaging the glass.

## REPLACING THE GASKET

The Emerald has 3/8" fiberglass gasket in the front door. To replace it, follow this procedure.

1. Open the door
2. Remove the existing gasket and clean its channel with a scraper or wire brush.
3. Lay a thin bead of gasket cement the entire length of the channel.
4. Lay the gasket in the channel with sufficient pressure that it stays in place.
5. Trim the excess from the end of the gasket so that it butts snugly against the other end without leaving a gap.
6. Close the door and apply firm pressure to seat the gasket evenly throughout.

## CLEANING THE GLASS

The glass may be cleaned with ordinary household glass cleaner and a soft cloth or paper towel.

**WARNING: Never clean the glass when it is hot. Do not use abrasive cleaners on the glass.**

## INSPECTING THE VENTING

An inspection of the venting system and a flue spillage test should be conducted by a qualified service technician during the annual service appointment to confirm that there is no blockage and that the system is in good repair. Any sections that are taken apart for the inspection must be reassembled and sealed as required.

## CLEANING THE LOG SET AND FIREBOX

During the annual inspection and maintenance appointment, the service person should clean dust, lint, and any light accumulation from the logs and the firebox area. An extra-soft brush should be used on the logs as they are extremely fragile; a vacuum cleaner may be used on the firebox. If at any time the logs cannot be removed or installed without forcing, the cause must be found. The logs must never be forced.

A test for flue spillage should be made annually to confirm that the venting system is unobstructed and in good working order.

### *Opening the Front Door*

Open the right side door to expose both the controls and the heat shield just inside the door.

Above and to the left of the control module is a cut-out in the heat shield through which can be seen a wing nut threaded on to a stud attached to the front door.

Loosen this nut by turning it counterclockwise.

*The wing nut that holds the front door is accessible through the cut-out in the side heat shield.*

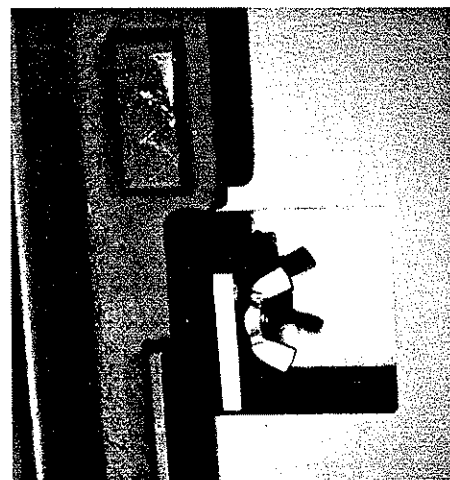

### *Cleaning the Logs*

**CAUTION:** The ceramic logs are durable and long-lasting when fitted properly. However, they are delicate and may be damaged easily if not handled with care. Handling damage to the ceramic logs is not covered by warranty.

**DO NOT HANDLE THE LOGS WHILE THEY ARE HOT.**



Rear log



Front log



Top log



Ember strip

Once the Emerald is cool, remove the top log from the firebox, brush it gently over a newspaper, and place it carefully to the side in a protected area.

Remove the ember strip, being careful to support it evenly so it does not break in the middle, and clean it as described in the previous step.

Remove the front log, and brush it clean as described in the previous steps.

Remove the back log, and clean it as well.

With the logs removed, vacuum any visible dust or lint from the firebox area.

### *Installing the Log Set*

Rotate and angle the pieces to maneuver them into position. **DO NOT FORCE.**

Place the rear log in position on the bottom of the firebox, slide it to the rear against the fireback, and center it.

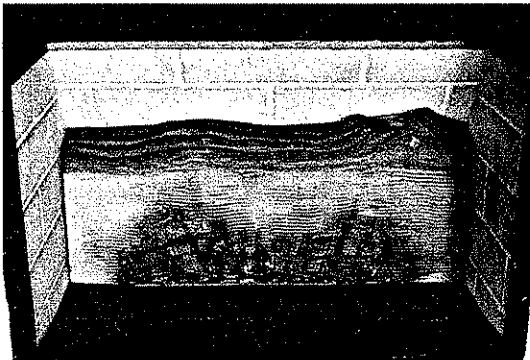

*The rear log, centered and against the fireback.*

Place the front log in position and slide it back against the rear log temporarily.

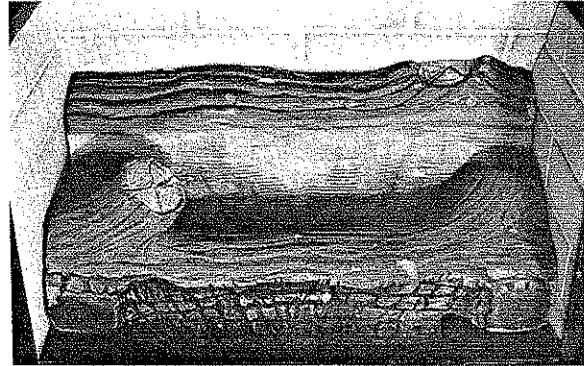

*The front log in position.*

Install the ember strip so that it is snug against the front of the heater, and then draw the front log forward until it contacts the ember strip. It will not move much.

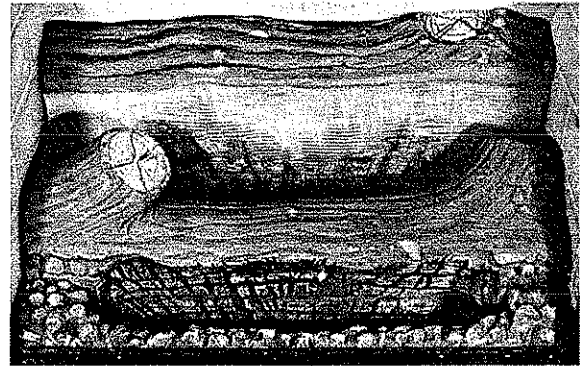

*The ember strip is placed so it is snug against the front.*

Lay the top log across both the rear and front logs, matching the keys in the bottom of this piece to the receiving pins of the other two logs.



*Keys on the bottom of the top log match pins on the rear and front logs for a sure fit.*

5. Close the door.
6. Thread the wing nut onto the end of the stud from which it was removed.
7. Tighten the wing nut until it is fully tightened. (See "Securing Front Door" illustration on page 6).

# Parts List

The following replacement parts for your Emerald B Vent are available from your Waterford dealer or from Waterford Irish Stoves, Inc., 16 Airpark Road, Suite 3, W. Lebanon, New Hampshire 03784. 1-603-298-5030.

ITEM	QTY	DESCRIPTION
1	1	Body Weldment
2	1	Fireback
3	1	Flame Baffle
4	1	Wing Plate
5	2	Wing Bracket, 45°
6	2	Wing Bracket, 90°
7	1	Log Support Plate
8a	1	Valve Bracket, Front
8b	1	Valve Bracket, Rear
9	1	Bottom Heat Shield
10	1	Right Side Heat Shield
11	1	Left Side Heat Shield
12	1	Inner Top Heat Shield (not shown)
13	1	Top Heat Shield
14	1	Valve Heat Shield
15	1	Rear Heat Shield
16	1	Switch Box
17	1	Hole Plug
18	1	Front
19	1	Front to Body Gasket (set)
20	1	Front Door
21	1	Front Door Gasket
22	2	Front Door Hinges
23	1	Right Side
24	1	Right Door
25	1	Right Door Gasket
26	2	Right Door Hinges
27	1	Left Side
28	1	Hob (Top)
29	4	Legs
30	1	Glass Panel
31	1	Glass Gasket
32	6	Glass Clips
33	1	Burner Assembly
34	1	Left Brick Panel
35	1	Right Brick Panel
36	1	Rear Brick Panel
37	1	Rear Log
38	1	Front Log
39	1	Ember Strip
40	1	Top Log
41	1	Pilot Assembly
42	1	3/8" IPS x 5/16" Male Elbow
43a	1	Main Burner Injector: LPG
43b	1	Main Burner Injector: NG
44	1	Air Shutter Adjuster Ass'y
45	1	Control Valve
46	1	Valve Extension Knob

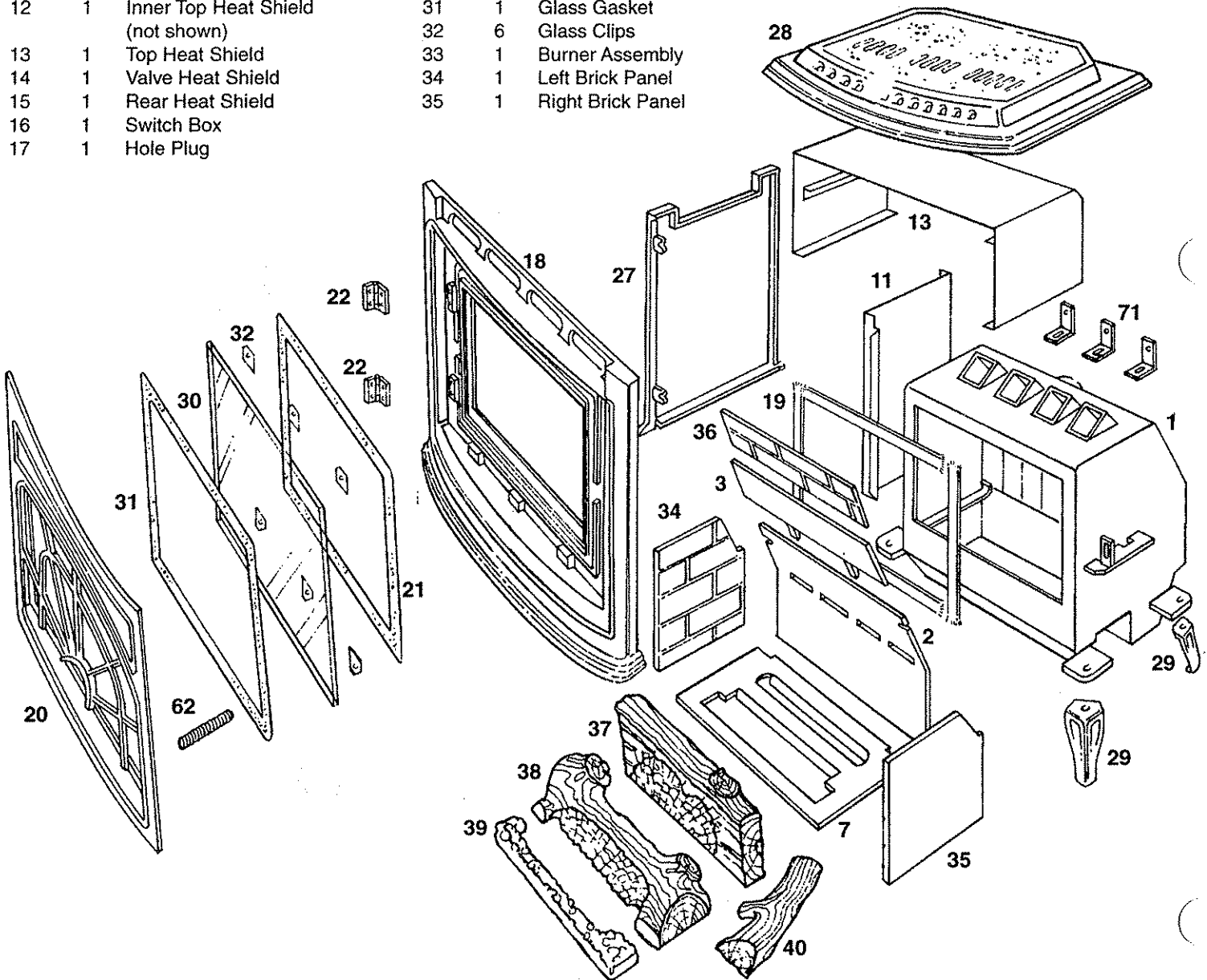

- 47 1 Regulator Extension Knob
- 48 1 3/8IPS X 5/ 16 Male Elbow (not shown)
- 49 1 Main Fuel Line
- 50 1 Pilot Fuel Line
- 51 1 LPG Pilot Injector (not shown)
- 52 1 NG Pilot Injector (not shown)
- 53 1 Piezo Igniter
- 54 1 PAL Nut (not shown)
- 55 1 On-Off-TStat Switch

- 56 1 Barrier Strip
- 57 1 Wiring Harness
- 58 3 Wiring Mounting Buttons
- 59 5 Wire Tie Wraps
- 60 1 3/8" IPS Nipple X 3" long
- 61 1 3/8" IPS to 1/2" Flare Elbow
- 62 1 Door Rod
- 63 1 Door Magnet
- 64 1 Vent Safety Switch Bracket
- 65 1 Wiring Harness Jumper

- 66 1 Elbow
- 67 1 Lock nut
- 68 1 Nipple
- 69 1 Vent Safety Switch
- 70 1 Thermocouple
- 71 3 Decorative sleeve brackets

**Optional Blower Kit (not shown)**

- 72 1 Speed Control w/On-Off
- 73 1 Temperature Switch
- 74 1 Connector
- 75 1 Cordset
- 76 1 Strain Relief
- 77 1 Grommet
- 78 1 Blower Housing Assembly
- 79 1 Blower

**Conversion Kits (not shown)**

- 80 1 NG Conversion Kit
- 81 1 LPG Conversion Kit

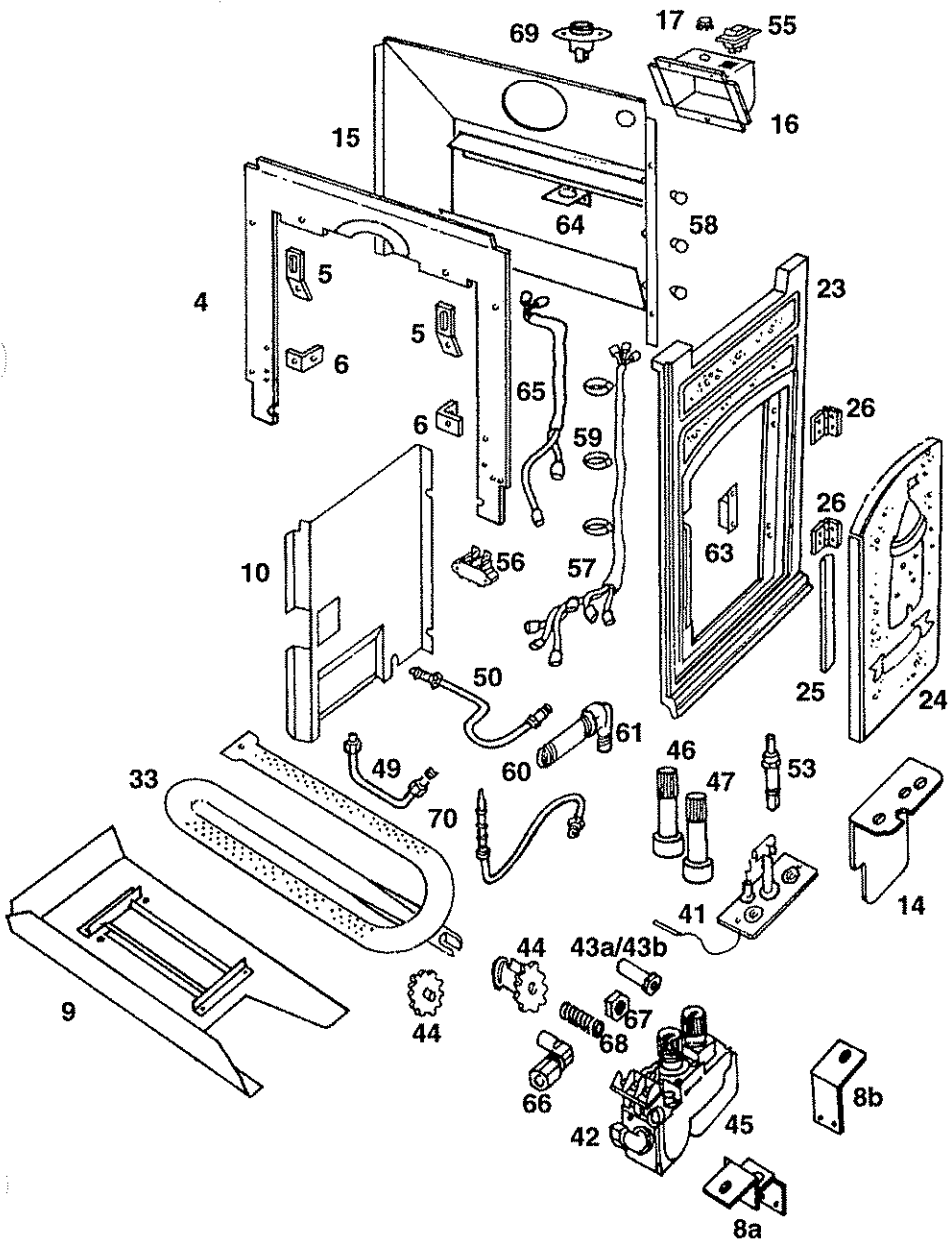



# Appendix A

## CONVERTING THE EMERALD FROM ONE GAS TO ANOTHER IN THE FIELD

**NOTE: THE CONVERSION SHALL BE CARRIED OUT IN ACCORDANCE WITH THE REQUIREMENTS OF THE PROVINCIAL OR LOCAL AUTHORITIES HAVING JURISDICTION AND IN ACCORDANCE WITH REQUIREMENTS OF THE NATIONAL FUEL GAS CODE, ANSI Z223.1 OR THE CAN/CGA-B149 INSTALLATION CODES.**

### Conversion Kit Components

1. Control Valve
2. Burner Injector
3. Pilot Injector
4. Conversion Label.

Conversion from one fuel to the alternate requires removing the control valve, heat shield, and bracket completely from the unit.

Remove the hob (top).

Removal of the right side facilitates the conversion. Open the front door by first opening the right side door and removing the wing nut from the stud.

With the front door open, remove the two Phillips head screws that secure the right side to the front and the Phillips head screw that secures the side to the firebox wall. Remove the side by pulling out the rear first, and then the front.

Disconnect the wire from the piezo ignitor by pulling down on it.

Lift the valve heat shield off by lifting straight up. The piezo ignitor will come along with the heat shield.

Remove the two 5/16" hex head bolts that hold the valve brackets to the leg pads (1/2" wrench).

Remove the four screws that hold the valve to the valve brackets.

Disconnect the thermocouple, main fuel line, pilot fuel line, thermopile leads, and wiring harness leads from the valve, carefully noting where each item is connected to the valve. Remove the valve.

### Replacing the Burner Injector

#### 1. Remove the Logs and Log Support Plate.

With the front door open, carefully remove the logs and the three brick panels and set them aside where they will be safe. Remove the log support plate by lifting up on one end and then "angling" it out through the front door opening.

#### 2. Remove the Burner.

First remove the sheet metal screw from the tab on the left rear end of the burner tube. Next, slide the burner off the fuel injector by pushing the burner

to the left. Remove the burner from the firebox. It will be necessary to angle the left end of the burner slightly upward and toward the front of the stove in order to clear the log support plate rib on the left side of the firebox.

#### 3. Remove the Burner Injector.

Follow the 5/16" diameter main fuel line to the 90° elbow adjacent to the recessed side wall of the firebox. As a precaution for preventing damage to the main fuel line while removing the burner injector, place a wrench on the 90° elbow in such a manner as to prevent it from rotating. Locate the burner injector on the inside of the firebox, on the right side near the burner air shutter adjuster gear. Using a 1/2" wrench or 1/2" deep socket, carefully loosen and remove the fuel injector.

#### 4. Install the New Injector.

Screw the injector on finger tight. Before tightening with a wrench, be sure you again prevent the 90° elbow from rotating by securing it with a wrench as in #3 above. Tighten the injector firmly but do not overtighten. It is okay if the injector is tight against the side wall of the firebox but not absolutely necessary.

#### 5. Replace the Burner.

Again it will be necessary to angle the burner into place to get it past the rib on the left firebox wall. It is also necessary to guide the right end of the burner onto the burner injector. Additionally, the burner air shutter adjuster gears must be aligned. The drive gear on the firebox wall can easily be rotated to align the teeth with the air shutter gear. Also, check to make sure that the two gears engage each other by at least two-thirds of their thickness. If not, it will be necessary to disengage the burner and screw the drive gear in or out as required. The burner must be seated in the two support cradles attached to the front of the firebox and the left rear end must sit on top of the support tab located on the left side of the firebox. Replace the sheet metal screw in the left rear end of the burner. This will prevent the burner from moving after installation.

#### 6. Replace the Log Support Plate, Brick Panels, and Logs.

Angle the log support plate through the front door opening and place it on the support ribs located on either side of the firebox. Once the plate is in place, push fully toward the rear and then pull fully forward. This will help ensure that the plate seats properly. Place the brick panels next by first installing the left side panel. Next insert the left end of the rear panel into the notch at the rear of the side panel. Lastly, carefully angle the right panel in place, watching the alignment of the rear notch and rear panel. The edges of the panels are somewhat fragile so care should be taken not to force the pieces together.



Next, replace the rear log, front log, ember strip, and top log. Instructions for placing the top log, as well as pictures showing how the firebox should look if the brick panels are properly installed, are shown on page 13.

### Replacing the Pilot Injector

Loosen the fitting on the 1/4" diameter pilot line (7/16" wrench) where it attaches to the pilot assembly.

Remove the pilot fuel line from the pilot assembly end line by pushing down.

At the end of the pilot fuel line you will find a thimble-shaped pilot injector. It will easily lift off the end of the pilot fuel line. Set this injector completely away from the fuel conversion kit as it may be difficult to differentiate the new pilot injector from the old. (NOTE: If the pilot fuel line does not have the injector at the end of it when removed, gently tap the pilot assembly with the end of your wrench. The pilot injector will drop out.)

Place the new pilot injector on the end of the pilot fuel line and insert into the fitting on the pilot assembly. Using a 7/16 wrench, tighten the fitting completely.

### Replacing the Valve

Install the valve brackets on the new valve and secure them using the four screws removed during disassembly. Holding the valve in position, reconnect the thermocouple, main fuel line, pilot line, thermopile, and wiring harness to the alternate fuel valve, making sure all fittings and wiring are in the same position as on the original valve. Exchange the valve extension handles from old valve to the new one: They simply pull off and push on.

Reinstall the two 5/16 bolts and washers that secure the valve brackets to the leg pads and tighten.

### Leak Testing

All fittings must be leak tested before use. It is most convenient to do this before the valve brackets and valve heat shield are reinstalled. Never exceed 1/2 psig during any leak testing while the unit is connected to the fuel supply system.

Tighten any fitting or fasteners as required and proceed with remaining component reinstallation.

### Completing the Conversion

Install the valve heat shield.

Reconnect the piezo ignitor wire.

Install the right side by reversing the removal procedure.

Close and lock the front door following the procedure outlined on page 6.

Install the appropriate conversion label on the rear of the stove.

**FUEL CONVERSION KIT #41021  
FOR WATERFORD EMERALD B VENT**  
Attach this label to the rear shield.

This appliance has been converted to NATURAL GAS fuel.  
Cet appareil a été converti au GAZ NATUREL.

Injector/Injecteur: 0MS 29

Input/Débit calorifique: 40,000

Manifold Pressure/  
Pression à la tubulure d'alimentation: 3.5

Inlet Pressure /  
Pression D'Arrivée: Min. 4.5 Max. 11.0

Date appliance was converted: \_\_\_\_\_

By \_\_\_\_\_

*The above label on the stove's rear heat shield indicates that the unit has been converted to burn natural gas.*

**FUEL CONVERSION KIT #41031  
FOR WATERFORD EMERALD B VENT**  
Attach this label to the rear shield.

This appliance has been converted to PROPANE fuel.  
Cet appareil a été converti au PROPANE.

Injector/Injecteur: 0MS 48

Input/Débit calorifique: 40,000

Manifold Pressure/  
Pression à la tubulure d'alimentation: 10.0

Inlet Pressure /  
Pression D'Arrivée: Min. 11.0 Max. 13.0

Date appliance was converted: \_\_\_\_\_

By \_\_\_\_\_

*This label on the stove's rear heat shield indicates that the unit has been converted to burn propane.*

**SEE WIRING DIAGRAM ON PAGE 8**

**CAUTION: LABEL ALL WIRES PRIOR TO DISCONNECTION WHEN SERVICING CONTROLS. WIRING ERRORS CAN CAUSE IMPROPER AND DANGEROUS OPERATION VERIFY PROPER OPERATION AFTER SERVICING.**

# Appendix B

## INSTALLATION OF OPTIONAL CONVECTION BLOWER PART NO. 40901

With the heater completely shut down and having cooled enough to be handled safely, follow these steps:

1. Remove the cast iron hob (top).
2. Remove the three screws that hold the switch box to the rear heat shield and put them aside for later re-use.
3. Tip the switch box to provide access.
4. Locate the snap-disc blower thermostat and mount it to the rear heat shield using two #4 X 1/2 Phillips head sheet metal screws. The pre-drilled holes for mounting are located near the large hole where the wiring harness enters the switch box. The snap disc may be mounted in either direction.
5. Remove the chrome-plated plug from the 3/8" diameter hole in the switch box.
6. Locate the speed control and insert the shaft through the 3/8" diameter hole in the switch box. Align the semi-circular pin on the speed control with the semi-circular hole in the switch box. Secure the speed control to the box with the special lock nut provided. Push down while turning the nut clockwise until tight.
7. Locate the black and white wires in the wiring harness. Connect the black wire to the nearest terminal on the snap disc. Connect the black wire from the speed control to the other snap disc terminal. Connect the white wire from the wiring harness to the white wire on the speed control.
8. Reinstall the switch box on the heat shield. Align the three slots on the switch box with the three holes in the heat shield. Make sure no wires are pinched, then re-install the three screws removed in step #1 and tighten them fully.
9. Install the blower control knob by aligning with the shaft on the speed control and push down firmly.
10. Locate and remove the four blower mounting fasteners.
11. Line up the four holes in the blower housing with the four mounting holes and re-insert the fasteners. Tighten all fasteners to ensure that the blower housing will not vibrate.  
Thread two 1/4" nuts on to the two studs that are located just inside the bottom heat shield, and tighten them.

Replace the bottom heat shield if you removed it.

12. Locate the black and white wires. They are connected to a two-pin connector and are in their own small sleeve, branching from the main wiring bundle. It may be necessary to remove a wire wrap to free the blower wiring from the shipping position. Look near the terminal strip located just behind the top of the right rear leg. For best access, it also may be necessary to remove the rear heat shield or to loosen one side of it by removing the two side screws.

13. Insert the two-pin connector plug into the two-pin connector receptacle located on the blower housing junction box near where the blower cord set exits. Make sure the plug "snaps" into the mating socket.

14. Plug the three-prong grounding plug into a properly grounded 120VAC receptacle.

**WARNING: This heater is equipped with a three-prong grounding plug that should be plugged directly into a properly grounded receptacle. Do not cut or remove the grounding prong from the plug.**

**The Emerald gas heater, when installed, must be electrically grounded in accordance with local codes or, in the absence of local codes, with the National Electrical Code, ANSI/NFPA 70 in the United States or the current Canadian Electrical Code CSA 22.1 in Canada.**

15. Turn the blower on by rotating the control knob clockwise. You will hear a click if the speed control was in the off position. The blower will not come on until the Emerald Direct Vent Heater reaches proper operating temperature. Once the blower has turned on, adjust the speed control to obtain the desired air flow.

The blower thermostat will automatically cycle the blower on and off as the unit heats up and cools down during use.

The blower may be shut off completely by rotating the control knob fully counterclockwise until it "clicks."

16. Always disconnect the blower cord from the grounded receptacle before any servicing.

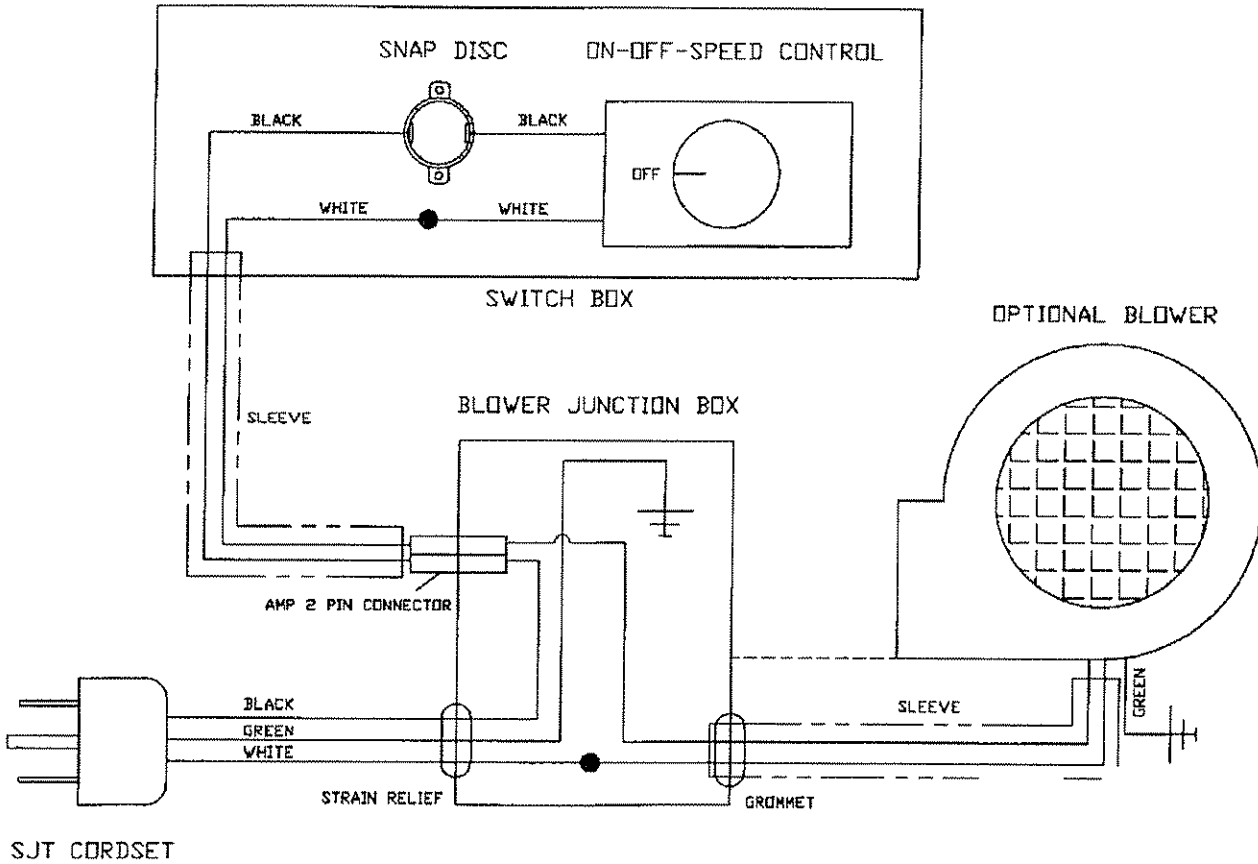

Electrical diagram for the Emerald Direct Vent Gas Heater's Optional Blower

CAUTION: LABEL ALL WIRES PRIOR TO DISCONNECTION WHEN SERVICING CONTROLS. WIRING ERRORS CAN CAUSE IMPROPER AND DANGEROUS OPERATION. VERIFY PROPER OPERATION AFTER SERVICING.

# Appendix C

## DE-RATING FOR HIGH ALTITUDE

For U.S. and Canadian installations, the Emerald Vented Gas Heater is approved for elevations up to 2000 feet (610 m) using the factory-installed burner injector. At elevations above 2000 feet (610 m), U.S. codes require a decrease in the input rating by changing the burner injector to a smaller size. The chart below lists by part numbers the appropriate injectors for both LP and natural gas at various altitudes.

Altitude	LPG Injector Size	Waterford Part No.	NG Injector Size	Waterford Part No.
0-2000'	48	41041	29	41101
2000-3000'	49	41051	30	41111
3000-4000'	49	41051	30	41111
4000-5000'	50	41061	1/8	41121
5000-6000'	50	41061	31	41131
6000-7000'	51	41071	31	41131
7000-8000'	51	41071	32	41141
8000-9000'	52	41081	33	41151

### Replacing the Burner Injector

#### 1. Remove the Logs and Log Support Plate.

Open the front door following the instructions on page 6 of this manual. Carefully remove the logs and the three brick panels and set them aside where they will be safe. Remove the log support plate by lifting up on one end and then "angling" it out through the front door opening.

#### 2. Remove the Burner.

First remove the sheet metal screw from the tab on the left rear end of the burner tube. Next, slide the burner off the fuel injector by pushing the burner to the left. Remove the burner from the firebox. It will be necessary to angle the left end of the burner slightly upward and toward the front of the stove in order to clear the log support plate rib on the left side of the firebox.

#### 3. Remove the Burner Injector.

Locate the control valve under the right end of the stove and follow the 5/16" diameter main fuel line from the front of the valve to the 90° elbow adjacent to the recessed side wall of the firebox. As a precaution for preventing damage to the main fuel line while

removing the burner injector, place a wrench on the 90° elbow in such a manner as to prevent it from rotating. Locate the burner injector on the inside of the firebox, on the right side near the burner air shutter adjuster gear. Using a 1/2" wrench or 1/2" deep socket, carefully loosen and remove the fuel injector.

NOTE: The difference in altitude derating requirements for the U.S. and Canada is simply a result of differences in testing standards between the two countries.

removing the burner injector, place a wrench on the 90° elbow in such a manner as to prevent it from rotating. Locate the burner injector on the inside of the firebox, on the right side near the burner air shutter adjuster gear. Using a 1/2" wrench or 1/2" deep socket, carefully loosen and remove the fuel injector.

#### 4. Install the New Injector.

Select the appropriate injector for your altitude from the chart above. Screw the injector on finger tight. Before tightening with a wrench, be sure you again prevent the 90° elbow from rotating by securing it with a wrench as in #3 above. Tighten the injector firmly but do not overtighten. It is okay if the injector is tight against the side wall of the firebox but not absolutely necessary.

#### 5. Replace the Burner.

Again it will be necessary to angle the burner into place to get it past the rib on the left firebox wall. It is also necessary to guide the right end of the burner onto the burner injector. Additionally, the burner air shutter adjuster gears must be aligned. The drive gear on the firebox wall can easily be rotated to align the teeth with the air shutter gear. Also, check

---

to make sure that the two gears engage each other by at least two-thirds of their thickness. If not, it will be necessary to disengage the burner and screw the drive gear in or out as required. The burner must be seated in the two support cradles attached to the front of the firebox and the left rear end must sit on top of the support tab located on the left side of the firebox. Replace the sheet metal screw in the left rear end of the burner. This will prevent the burner from moving after installation.

*6. Replace the Log Support Plate, Brick Panels, and Logs.*

Angle the log support plate through the front door opening and place it on the support ribs located on either side of the firebox. Once the plate is in place, push fully toward the rear and then pull fully forward. This will help ensure that the plate seats properly. Place the brick panels next by first installing the left side panel. Next insert the left end of the rear panel into the notch at the rear of the side panel. Lastly, carefully angle the right panel in place, watching the alignment of the rear notch and rear panel. The edges of the panels are somewhat fragile so care should be taken not to force the pieces together. Next, replace the rear log, front log, ember strip, and top log. Instructions for placing the top log as well as pictures showing how the firebox should look if the brick panels are properly installed are shown on page 13.

*7. Close Door and Tighten Wing Nut.*

See page 6 for details on closing the door and tightening the wing nut.

# Appendix D

## EMERALD VENTED GAS HEATER SPECIFICATIONS

Tested to ANSI Z21.11.1-1993, CAN 1-2.1-M89, CAN/CGA 2.17-M91.

	<b>NATURAL GAS</b>	<b>PROPANE</b>
Input Rating (Btu/hr) (0-2000 ft.) (0-610 m)	40,000	40,000
Min. Input Rating (Btu/hr) (0-2000 ft.) (0-610 m)	26,000	28,500
Injector Size (DMS) (0-2000 ft.) (0-610 m)	29	48
Manifold Pressure (in w.c./kPa)	3.5/0.87	10.0/2.49
Minimum Inlet Pressure (in w.c./kPa)	5.0/1.25	11.0/2.74
Maximum Output (Btu/hr) (0-2000 ft.) (0-610 m)	31,000	31,000
Input Rating (Btu/hr) (2000-4500 ft.) (610-1370 m)	38,000	38,000
Injector Size (DMS) (2000-4500 ft.) (610-1370 m)	30	49
AFUE (seasonal efficiency; minimum venting)	68.4%	72.2%
Steady State Efficiency (max. input, blower on High)	73%	75.1%

### MINIMUM CLEARANCES FROM COMBUSTIBLE CONSTRUCTION

Unit to left sidewall	6 in. (150 mm)
Unit to right sidewall	10 in. (255 mm)
Unit corner to walls	2 in. (50 mm)
Rear of unit to back wall	5 in. (125 mm)
Vertical vent pipe to back wall	2 in. (50 mm)
Unit to alcove ceiling	18 in. (460 mm)
Maximum alcove depth	24 in. (610 mm)

Electrical Rating: 120 Volts, 60 Hz., 1.2 Amps

Stove weight: 350 lbs.