

HI1150 Wood Cast Insert

Owner's & Installation Manual



www.hampton-fire.com
French Manual: <https://bit.ly/2OCYeIi>
Manuel en Français : <https://bit.ly/2OCYeIi>

Tested by:



Installer: Please complete the details on the back cover
and leave this manual with the homeowner.
Homeowner: Please keep these instructions for future reference.

Thank you for purchasing a
Hampton FIREPLACE PRODUCT.

The pride of workmanship that goes into each of our products will give you years of trouble-free enjoyment. Should you have any questions about your product that are not covered in this manual, please contact the **HAMPTON DEALER** in your area.

"This wood heater has a manufacturer set minimum low burn rate that must not be altered. It is against federal regulations to alter this setting or otherwise operate this wood heater in a manner inconsistent with operating instructions in this manual." Failure to follow the manual details can lead to smoke and CO emissions spilling into the home. It is recommended to have monitors in areas that are expected to generate CO such as heater fueling areas.

"U.S. ENVIRONMENTAL PROTECTION AGENCY Certified to comply with 2020 particulate emission standards using cord wood." Model Hampton HI1150 – 1.7g/hr.

"This manual describes the installation and operation of the Hampton HI1150 wood heater. This heater meets the 2020 U.S. Environmental Protection Agency's cord wood emission limits for wood heaters. Under specific test conditions this heater has been shown to deliver heat at rates ranging from 12,800 BTU/hr to 39,100 BTU/hr. Efficiency is determined using the B415 method resulting in lower and higher heat values. This heater generates the best efficiency when operated using well-seasoned wood and installed in the main living areas where the majority of the chimney is within the building envelope.

It is against federal regulation to operate this wood heater in a manner inconsistent with operating instructions in this manual."

"This heater is designed to burn natural wood only. Higher efficiencies and lower emissions generally result when burning air dried seasoned hardwoods, as compared to softwoods or to green or freshly cut hardwoods."

DO NOT BURN:

- Treated wood
- Coal
- Garbage
- Cardboard
- Solvents
- Colored Paper
- Bio Bricks
- Trash
- **Lawn clippings or yard waste**
- **Materials containing rubber including tires**
- **Materials containing plastic**
- **Waste petroleum products , paints or paint thinners or asphalt products**
- **Materials containing asbestos**
- **Construction or demolition debris**
- **Railroad ties**
- **Manure or animal remains**
- **Saltwater driftwood or other previously salt water saturated materials**
- **Unseasoned wood**
- **Paper products, cardboard, plywood or particle board. The prohibition against burning these materials does not prohibit the use of fire starters made from paper, cardboard, saw dust, wax and similar substances for the purpose of starting a fire in a wood heater.**

Burning these materials may result in release of toxic fumes or render the heater ineffective and cause smoke.

The authority having jurisdiction (such as Municipal Building Department, Fire Department, Fire Prevention Bureau, etc.) should be consulted before installation to determine the need to obtain a permit.

ULC628-2022 - Canada

This fireplace insert must be installed with a continuous chimney liner of 5.5 or 6 inch diameter extending from the fireplace insert to the top of the chimney. The chimney liner must conform to the class 3 requirements of CAN/ULS-S635 Standard for lining systems for existing Masonry or factory built chimneys and vents or to the requirements of CAN/ULC-S640, Standard for lining systems for new masonry chimneys.

UL1482-2022 - U.S.A

A chimney complying with the requirement for type HT chimneys in the standard for chimneys, factory built residential and building heating appliance UL103 or a code approved masonry chimney liner with a flue liner.

This fireplace insert must be installed with a continuous chimney liner of 5.5 or 6 inch diameter extending from the fireplace insert to the top of the chimney.

When this room heater is not properly installed, a house fire may result. To reduce the risk of fire follow the installation instructions. Contact local building or fire official as about restrictions and installation requirements in your area.

Hi1150 is certified to CAN/ULC 628-2022 and UL 1482-2022.

SAVE THESE INSTRUCTIONS

 **NATIONAL FIREPLACE INSTITUTE**
We recommend that our products be installed and serviced by professionals who are certified in the U.S. by the National Fireplace Institute® (NFI) or in Canada by Wood Energy Technical Training (WETT).
 **Wood Energy Technical Training**
www.nficertified.org

 **WARNING: Cancer and Reproductive Harm**
www.P65Warnings.ca.gov

919-874

table of contents

Safety

Copy of the Safety Decal (HI1150)	4
---	---

Dimensions

Unit Dimensions with Standard Flue Adaptor	5
Unit Dimensions with Offset Flue Adaptor	6

Installation

Masonry Fireplace Clearances.....	7
Fireplace Specifications.....	7
How to Determine if Alternate Floor Protection Materials are Acceptable.....	8
Installing Into a Masonry Fireplace	9
Before Installing Your Insert.....	9
Chimney Specifications	9
Installation Into a Factory-built Fireplace.....	10
Installing Your Insert	10
Fan & Cast Faceplate Installation.....	11
Brick Installation	13
Baffle Installation	14
Stainless Steel Smoke Deflector Installation.....	15

Operating Instructions

Seasoned Wood	16
Operating Instructions	17
Draft Control.....	17
First Fire.....	17
Fan Operation	18
Ash Disposal	19
Safety Precautions.....	19
Safety Guidelines and Warnings.....	19

Maintenance

Maintenance	20
Creosote.....	20
Ways to Prevent and Keep Unit Free of Creosote	20
Wood Storage	20
Fan Maintenance	20
Door Gasket.....	21
Glass Cleaning	21
Door Removal	21
Glass Replacement	21
Handle Replacement.....	21
Latch Adjustment	22
Secondary Air Tube Removal/Installation.....	23
Vertical Stainless Deflector Replacement	24
Annual Maintenance	25

Parts List

Main Assembly.....	26
Cast Faceplate	27
Brick Panels	27

Warranty

Warranty	28
Recycling	33

ALL PICTURES / DIAGRAMS SHOWN THROUGHOUT THIS MANUAL ARE FOR ILLUSTRATION PURPOSES ONLY. ACTUAL PRODUCT MAY VARY DUE TO PRODUCT ENHANCEMENTS.

CAUTION: To avoid burns or wood splinters, when opening/closing the fuel door or adding wood to the fire, You should always wear appropriate protective gloves to protect your hands from the heat being emitted from this fireplace.





safety decal

Copy of the HI1150 Safety Decal

This is a copy of the label that accompanies each **HI1150 Wood Insert**. We have printed a copy of the contents here for your review.

NOTE: Regency units are constantly being improved. Check the label on the unit and if there is a difference, the label on the unit is the correct one.

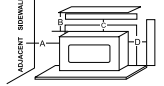
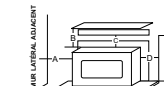
The serial # label will be affixed to a metal plate along with a black chain underneath the firebox. The fan assembly (if installed) would need to be removed which would expose the serial # decal.

(Duplicate Serial #) 546	
	LISTED MASONRY FIREPLACE INSERT CERTIFIED FOR USE IN CANADA AND U.S.A. MODEL: HI1150 CERTIFIED TO: CAN/ULC 628:2022 / UL-1482-2022
 546	
U.S. ENVIRONMENTAL PROTECTION AGENCY CERTIFIED TO COMPLY WITH 2020 PARTICULATE EMISSION STANDARDS USING CORD WOOD. TESTED TO ASTM E3053. MODEL REGENCY HI1150 - 1.76 / HR. THIS WOOD HEATER NEEDS PERIODIC INSPECTION AND REPAIR FOR PROPER OPERATION. CONSULT THE OWNER'S MANUAL FOR FURTHER INFORMATION. IT IS AGAINST FEDERAL REGULATIONS TO OPERATE THIS WOOD HEATER IN A MANNER INCONSISTENT WITH THE OPERATING INSTRUCTIONS IN THE OWNER'S MANUAL.	
INSTALL AND USE ONLY IN ACCORDANCE WITH THE MANUFACTURER'S INSTALLATION AND OPERATING INSTRUCTIONS. INSTALL AND USE ONLY IN MASONRY FIREPLACE ONLY. NOT TO BE INSTALLED IN ANY FACTORY-BUILT FIREPLACE. CONTACT LOCAL BUILDING OR FIRE OFFICIALS ABOUT RESTRICTIONS AND INSTALLATION INSPECTION IN YOUR AREA.	
MINIMUM CLEARANCES TO COMBUSTIBLE MATERIALS (MEASURED FROM SIDE/TOP OF DOOR)	
ADJACENT SIDEWALL MANTEL TOP FACING SIDE FACING	A) 15 in / 380 mm B) 20 in / 510 mm C) 14 in / 355 mm D) 7 7/8 in / 200 mm
	
COMBUSTIBLE FLOOR MUST BE PROTECTED BY NON-COMBUSTIBLE MATERIAL EXTENDING (E) 16 IN / 405MM TO FRONT AND (G) 8IN / 205MM TO SIDES FROM FUEL DOOR. IN CANADA MUST EXTEND 18" TO FRONT. THERMAL INSULATION WITH A R VALUE = 1.4 AT A DISTANCE OF 18" FROM FRONT OF DOOR OPENING FOR CANADA AND 16" FOR USA. IF UNIT RAISED 4.5" FROM FLOOR, NO THERMAL INSULATION IS REQUIRED.	
COMPONENTS REQUIRED FOR INSTALLATION: 5.5" (140mm) or 6" (152mm) STAINLESS STEEL LINER LISTED CHIMNEY LINER. OPTIONAL COMPONENT: FAN PART #210-911/210-915, ELECTRICAL RATING: VOLTS 115, 60 HZ, 0.6 AMPS DANGER: RISK OF ELECTRIC SHOCK. DISCONNECT POWER BEFORE SERVICING UNIT. DO NOT REMOVE BRICKS OR MORTAR IN MASONRY FIREPLACE. FOR USE WITH SOLID WOOD FUEL ONLY. DO NOT USE GRATE OR ELEVATE FIRE. DO NOT CONNECT THIS UNIT TO A CHIMNEY FLUE SERVING ANOTHER APPLIANCE. BUILD WOOD FIRE DIRECTLY ON HEARTH. OPERATE WITH FEED DOOR CLOSED, OPEN TO FEED FIRE ONLY. REPLACE GLASS ONLY WITH CERAMIC GLASS (5MM). INSPECT AND CLEAN CHIMNEY FREQUENTLY. UNDER CERTAIN CONDITIONS OF USE CREOSOTE BUILD-UP MAY OCCUR RAPIDLY. DO NOT OVERFIRE, IF INSERT GLOWS YOU ARE OVER-FIRING. CAUTION: MOVING PARTS MAY CAUSE INJURY. DO NOT OPERATE UNIT WITH A REMOVED PART OR PARTS.	
CERTIFIÉ CONFORME AUX NORMES 2020 DU U.S. ENVIRONMENTAL PROTECTION AGENCY EN MATIÈRE D'ÉMISSION DE PARTICULES DE BOIS EN UTILISANT LE BOIS DE CORDE. HOMOLOGUÉ AVEC LA ASTM E3053. MODÈLE REGENCY HI1150 - 1.7 G / H. CET APPAREIL DE CHAUFFAGE AU BOIS DOIT ÊTRE INSPECTÉ PÉRIODIQUEMENT ET RÉPARÉ POUR FONCTIONNER CORRECTEMENT. CONSULTER LE MANUEL D'INSTALLATION POUR PLUS D'INFORMATION. LA RÉGLEMENTATION FÉDÉRALE INTERDIT DE FAIRE FONCTIONNER UN TEL APPAREIL SI LES CONSIGNES D'UTILISATION CONTENUES DANS LE PRÉSENT MANUEL NE SONT PAS RESPECTÉES.	
D'INSTALLATION ET D'UTILISATION DU FABRICANT. À INSTALLER ET À UTILISER UNIQUEMENT DANS UN FOYER EN MAÇONNERIE OU UN FOYER PRÉFABRIQUÉ. CONTACTEZ LES AUTORITÉS LOCALES EN BÂTIMENT OU INCENDIE POUR CONNAÎTRE LES RESTRICTIONS D'INSTALLATION ET LES RÈGLES D'INSPECTION DANS VOTRE RÉGION.	
DÉGAGEMENTS MINIMAUX AUX MATÉRIAUX COMBUSTIBLES (MESURES PRISES DEPUIS LE CÔTÉ / HAUT DE LA PORTE)	
MUR LATÉRAL ADJACENT MANTEAU PAREMENT SUPÉRIEUR PAREMENT LATÉRAL	A) 15 po / 380 mm B) 20 po / 510 mm C) 14 po / 355 mm D) 7 7/8 po / 200 mm
	
LE PLANCHER COMBUSTIBLE DOIT ÊTRE PROTÉGÉ PAR UN MATÉRIAU NON COMBUSTIBLE S'ÉTENDANT SUR (E) 16 PO / 405MM À L'AVANT ET SUR (G) 8 PO / 205MM ENTRE LES CÔTÉS ET LA PORTE DE CHARGEMENT DU COMBUSTIBLE. PROLONGEMENT SUR 18 PO À L'AVANT AU CANADA. ISOLATION THERMIQUE AVEC UNE VALEUR R = 1.4 À UNE DISTANCE DE 18 PO DEPUIS L'AVANT DE L'OUVRETTURE DE LA PORTE AU CANADA ET 16 PO AUX ÉTATS-UNIS. SI L'APPAREIL EST SURÉLEVÉ À 4,5 PO DU SOL, AUCUNE ISOLATION THERMIQUE N'EST REQUISE.	
PIÈCES OBLIGATOIRES POUR L'INSTALLATION : GAINÉ DE CHEMINÉE HOMOLOGUÉE EN ACIER INOXYDABLE DE 5,5 PO (140mm) ou 6 PO (152mm). PIÈCE EN OPTION : VENTILATEUR PIÈCES N° 210-911 / 210-915. CARACTÉRISTIQUES ÉLECTRIQUES : 115 VOLTS, 60 HZ, 0,6 AMPS. DANGER : RISQUE D'ÉLECTROCUTION. DÉBRANCHER LE COURANT AVANT DE PROCÉDER À L'ENTRETIEN DE L'APPAREIL. NE PAS RETIRER LES BRIQUES OU LE MORTIER DU FOYER EN MAÇONNERIE. À UTILISER AVEC UN COMBUSTIBLE SOLIDE EN BOIS SEULEMENT. NE PAS UTILISER DE GRILLE NI SURÉLEVER LE FEU. NE PAS CONNECTER CET APPAREIL À UN CONDUIT DE CHEMINÉE DESSERVANT UN AUTRE APPAREIL. FAIRE UN FEU DE BOIS DIRECTEMENT SUR L'ÂTRE. FAIRE FONCTIONNER L'APPAREIL AVEC LA PORTE DE CHARGEMENT FERMÉE. L'OUVRIR SEULEMENT POUR ALIMENTER LE FEU. REMPLACER LA VITRE SEULEMENT AVEC UNE VITRE EN CÉRAMIQUE (5MM). FAIRE INSPECTER ET RAMONER LA CHEMINÉE À INTERVALLES RÉGULIERS. ACCUMULATION RAPIDE DE CRÉOSOTE DANS CERTAINES CONDITIONS. NE PAS SURCHAUFFER : SI L'ENCASTRABLE EST ROUGEoyANT, L'APPAREIL SURCHAUFFE. ATTENTION : LES PIÈCES AMOVIBLES PEUVENT ENTRAÎNER DES BLESSURES. NE PAS FAIRE FONCTIONNER L'APPAREIL SI UNE OU PLUSIEURS PIÈCES ONT ÉTÉ ENLEVÉES.	
ATTENTION / DANGER	
	
HOT WHILE IN OPERATION DO NOT TOUCH. KEEP CHILDREN, CLOTHING AND FURNITURE AWAY. CONTACT MAY CAUSE SKIN BURNS. READ ABOVE INSTRUCTIONS.	
APPAREIL CHAUD LORSQU'IL FONCTIONNE. NE PAS TOUCHER. GARDER À DISTANCE DES ENFANTS, DES VÊTEMENTS ET DU MOBILIER. TOUT CONTACT PEUT CAUSER DES BRÛLURES. LIRE LES INSTRUCTIONS CI-DESSUS.	
MANUFACTURED BY / FABRIQUÉ PAR : FPI FIREPLACE PRODUCTS INTERNATIONAL LTD. 6988 VENTURE ST. DELTA, BC V4G 1H4	
920-189b	

DATE OF MANUFACTURE / DATE DE FABRICATION
 MADE IN CANADA / FAIT AU CANADA

Unit Dimensions with Standard Flue Adaptor

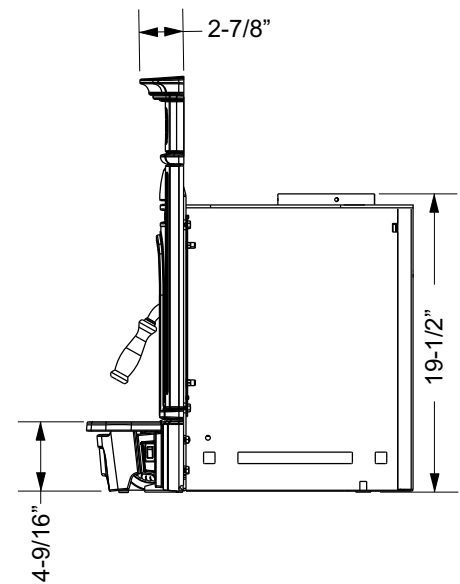
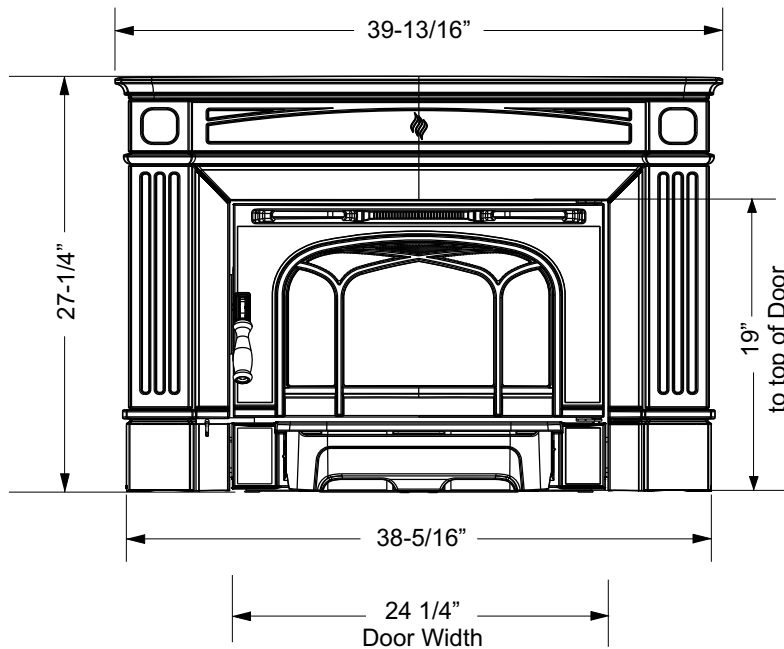
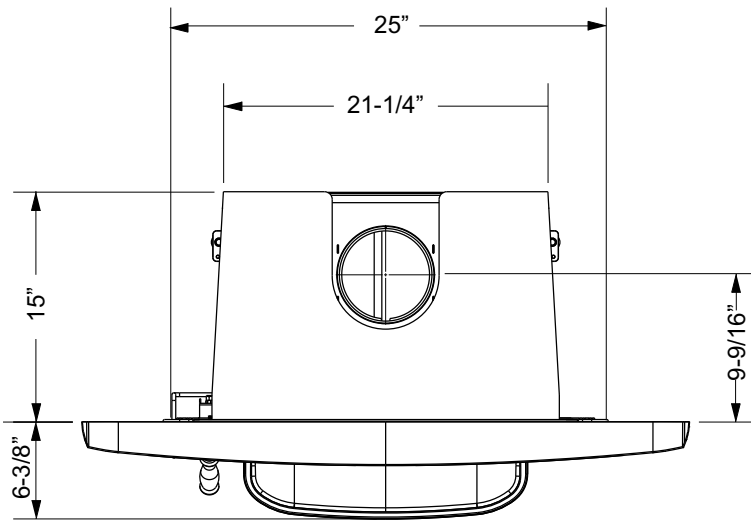

6" (152mm) Diameter
STANDARD FLUE ADAPTOR (172-942)

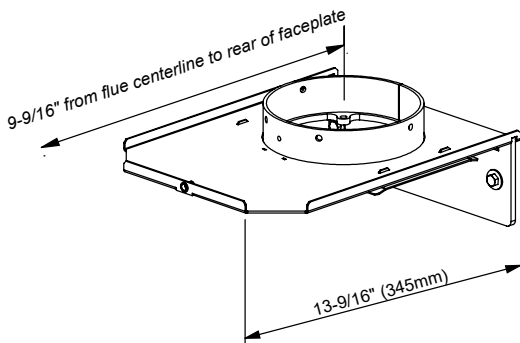

NOTE:
Before assembling your Insert, use these dimensions to ensure appropriate clearances will be met (refer to Masonry and Factory Built Fireplace Clearances section).

dimensions

Unit Dimensions with Offset Flue Adaptor

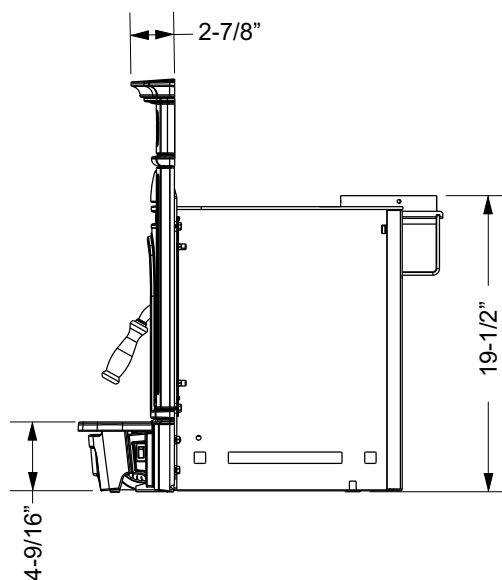
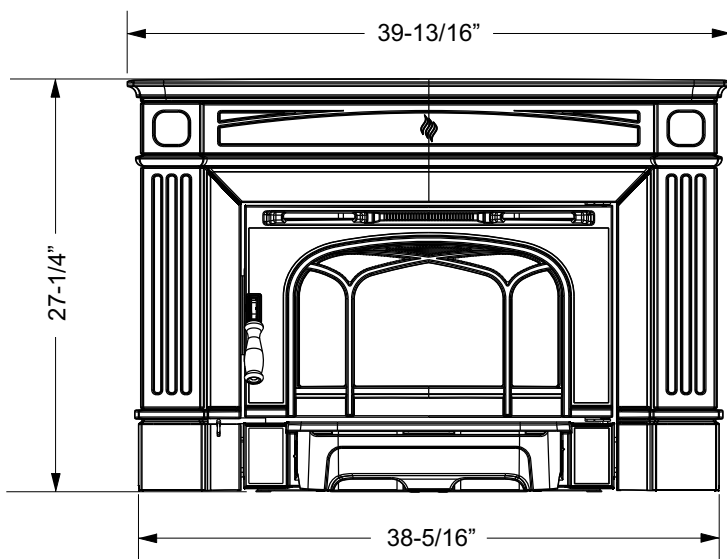
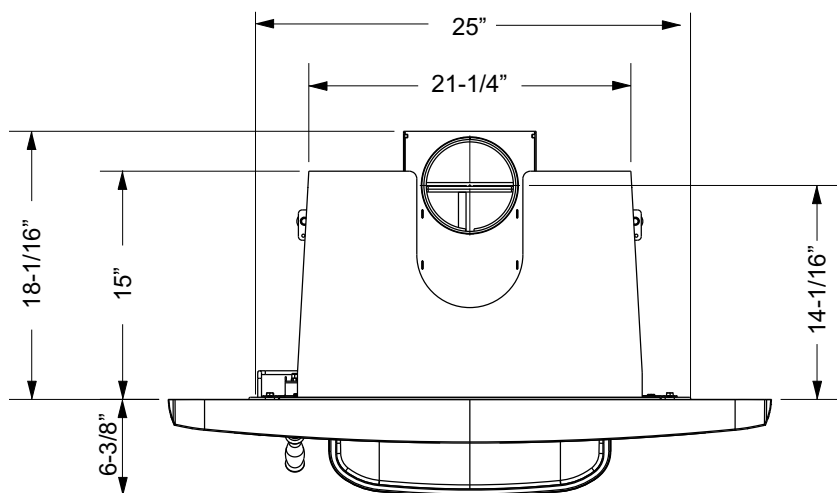

6" (152mm) Diameter
STANDARD FLUE ADAPTOR (172-946)

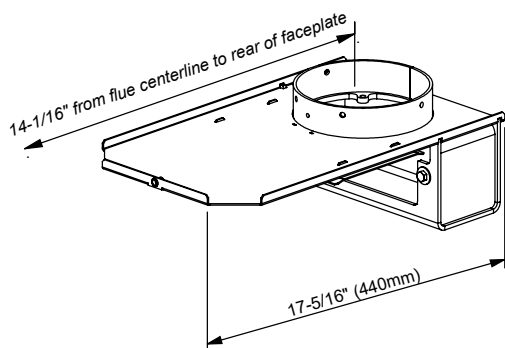

NOTE:
Before assembling your Insert, use these dimensions to ensure appropriate clearances will be met (refer to Masonry and Factory Built Fireplace Clearances section).

Masonry Fireplace Clearances

The minimum required clearances to combustible materials when installed into a masonry fireplace are listed below.

Unit HI1150	Adjacent Side Wall (to side) A**	Mantel*** (to top) B**	Top Facing (to top) C**	Side Facing (to side) D**	Minimum Hearth Extension* E	Minimum Hearth Side Extension* F	From Top of Door (Reference Dimension Only) G	From Side of Door (Reference Dimension Only) H
	15" (381 mm)	15" (381 mm) for 3-1/2" (89 mm) mantel	14" (355 mm)	7 7/8"(200 mm)	16" (406 mm) USA 18"(457 mm) Canada	8" (203 mm)	19" (483 mm)	14 - 1/4" (362mm)
		20" (508 mm) for 12"(305 mm) mantel						

Note: Side and Top facing is a maximum of 1.5" thick.
**Measured from side/top of door.

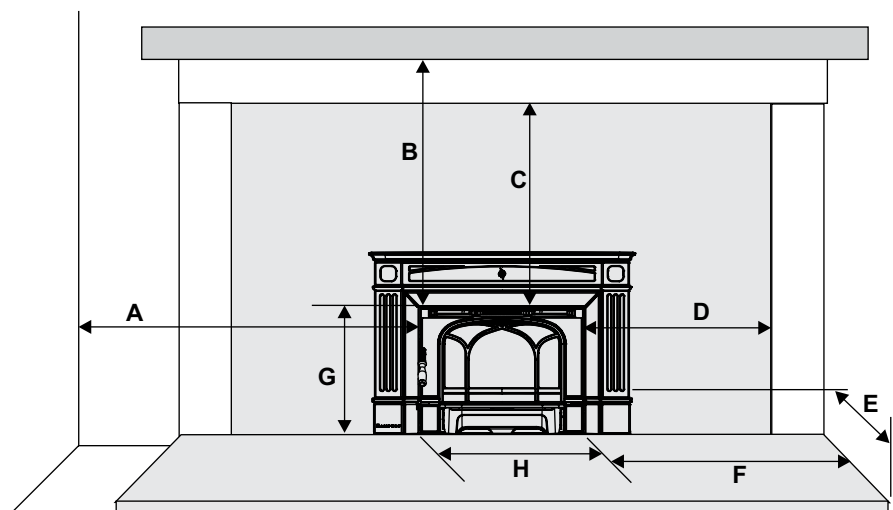
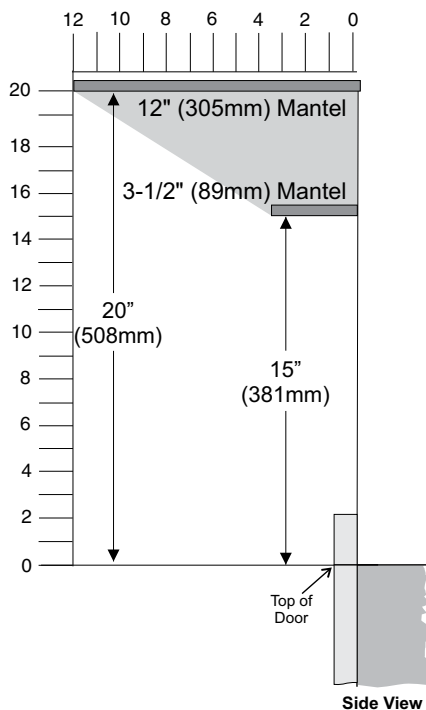

Clearance Diagram for installations

*Floor Protection

Thermal insulation/protection with a R value of 1.4 at a distance of 18" from door opening is required for Canada and 16" for USA.

If unit raised minimum 4.5" from hearth, no thermal protection is required.

Please check to ensure that your floor protection and hearth will meet the standards for clearance to combustibles. Your hearth extension must be made from a non-combustible material. Extending 16" for US and 18" for Canada—measured from the fuel loading door opening.

F measurement (minimum hearth extension) is taken from the side of the door for both U.S.A/Canada.

Fireplace Specifications

Your fireplace opening requires the following minimum sizes:

Height:	19-5/8" (499 mm)
Width:	25" (635 mm)
Depth:	
(w/ standard flue adaptor)	15" (381 mm)
(w/ offset flue adaptor)	18-1/16" (459 mm)

Faceplate Dimensions:

Height	27-1/4" (692 mm)
Width	38-5/16" (973 mm)

Clearances are critical.

***Mantel can be installed anywhere in shaded area or higher using the above scale.

installation

How to Determine if Alternate Floor Protection Materials are Acceptable

All floor protection must be noncombustible (i.e. metals, brick, stone, mineral fiber boards, concrete board etc.). The noncombustible floor protection specified includes some form of thermal designation such as R-value (thermal resistance) or k-factor (thermal conductivity).

Thermal Resistance: R Value

The R value is a measure of a material's resistance to heat transfer. R value is convenient when more than one material is used since you can add the R values together, whereas you cannot do this for k value. The HIGHER the R factor means less heat is being conducted through the non-combustible material to the combustible material beneath it. The R value of a material must be equal or larger than the required R value to be acceptable.

Example : The specified floor protector should be 3/8" (18mm) thick material with a K - factor of 0.84. The proposed alternative is 4" (100mm) brick with a C-factor of 1.25 over 1/8" (3mm) mineral board with a K-factor of 0.29.

Step (a):

Use formula above to convert specification to R-value.

$$R = 1/k \times T = 1/0.84 \times .75 = 0.893.$$

Step (b):

Calculate R of proposed system.

4" brick of C = 1.25, therefore

$$R_{\text{brick}} = 1/C = 1/1.25 = 0.80$$

1/8" mineral board of k = 0.29, therefore

$$R_{\text{min.bd.}} = 1/0.29 \times 0.125 = 0.431$$

$$\text{Total R} = R_{\text{brick}} + R_{\text{mineral board}} = 0.8 + 0.431 = 1.231.$$

Step (c):

Compare proposed system R of 1.231 to specified R of 0.893. Since proposed system R is greater than required, the system is acceptable.

DEFINITIONS

Thermal Conductance:

$$C = \text{Btu} = \text{W}$$

$$(\text{hr})(\text{ft}^2)(\text{oF})(\text{m}^2)(\text{K})$$

Thermal Conductivity:

$$k = (\text{Btu})(\text{inch}) = \text{W} = \text{Btu}$$

$$(\text{hr})(\text{ft}^3)(\text{oF})(\text{m})(\text{K})(\text{hr})(\text{ft})(\text{oF})$$

Thermal Resistance:

$$R = (\text{ft}^2)(\text{hr})(\text{oF}) = (\text{m}^2)(\text{K})\text{Btu}$$

Installation into a Masonry Fireplace

Regency Inserts are constructed with the highest quality materials and assembled under strict quality control procedures that insure years of trouble free and reliable performance.

It is important that you read this manual thoroughly and fully understand the safe installation and operating procedures. The more you understand the way your Regency Insert operates, the more enjoyment you will experience from knowing that your unit is operating at peak performance.

WARNING: The room heater shall not be installed in a factory-built fireplace.

Before Installing Your Insert

1. Please read this entire manual before you install and use your new wood insert. Failure to follow instructions may result in property damage, bodily injury or even death. Install and use only in accordance with manufacturer's installation and operating instructions.
2. Check your local building codes - Building Inspection Department. You may require a permit before installing your insert. **Be aware that local codes and regulations may override some items in the manual.**

WARNING: Careless installation is the major cause of safety hazard. Check all local building and safety codes before installation of unit.
3. Notify your home insurance company that you plan to install a fireplace insert or hearth heater.
4. Your fireplace insert is heavy and requires two or more people to move it safely. The insert can be badly damaged by mishandling.
5. If your existing fireplace damper control will become inaccessible once you have installed your Regency Insert, you should either remove or secure it in the open position.
6. Inspect your fireplace and chimney prior to installing your insert to determine that it is free from cracks, loose mortar or other signs of damage. If repairs are required, they should be completed before installing your insert. Do not remove bricks or mortar from your masonry fireplace.
7. **Do not connect the insert to a chimney system servicing another appliance or an air distribution duct.**

Chimney Specifications

Before installing, check and clean your chimney system thoroughly. If in doubt about its condition, seek professional advice. Your Regency Insert is designed for installation into a masonry fireplace that is constructed in accordance with the requirements of "The Standard for Chimneys, Fireplaces, Vents, and Solid Fuel Burning Appliance", N.F.P.A. 211, the National Building Code of Canada, or the applicable local code requirements.

The appliance, when installed, must be electrically grounded in accordance with local codes or, in the absence of local codes, with the National Electrical Code, ANSI/NFPA 70, or the Canadian Electrical code, CSA C22.1.

Regency Inserts are designed to use either a 5.5" (140mm) or 6" (152mm) flue.

ULC628-2022 - Canada

This fireplace insert must be installed with a continuous chimney liner liner of 5.5 or 6 inch diameter extending from the fireplace insert to the top of the chimney. The chimney liner must conform to the class 3 requirements of CAN/ULS-S635 Standard for lining systems for existing Masonry or factory built chimneys and vents or to the requirements of CAN/ULC-S640, Standard for lining systems for new masonry chimneys.

UL1482-2022 - U.S.A

A chimney complying with the requirement for type HT chimneys in the standard for chimneys, factory built residential and building heating appliance UL103 or a code approved masonry chimney liner with a flue liner.

This fireplace insert must be installed with a continuous chimney liner liner of 5.5 or 6 inch diameter extending from the fireplace insert to the top of the chimney. When this room heater is not properly installed, a house fire may result. To reduce the risk of fire follow the installation instructions. Contact local building or fire official as about restrictions and installation requirements in your area.

Draft

Draft is the force which moves air from the appliance up through the chimney. The amount of draft in your chimney depends on the length of the chimney, local geography, nearby obstructions and other factors. Too much draft may cause excessive temperatures in the appliance and may cause damage. An uncontrollable burn or excessive temperature indicates excessive draft. Inadequate draft may cause back puffing into the room and plugging of the chimney. Inadequate draft will cause the appliance to leak smoke into the room through appliance and chimney connector joints. Ensure the heater is installed in areas that are not too close to neighbors or in valleys that would cause unhealthy air quality or nuisance conditions.

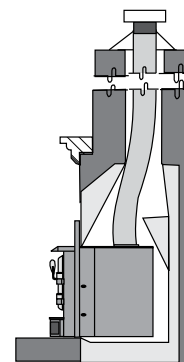

Recommended chimney height from top of flue collar:
Minimum 15 feet (4.6 meters)

NOTE

If the fireplace has been modified to accommodate a fireplace liner, the installer is to attach the metal tag to the fireplace using screws or nails, in a location readily visible should the fireplace insert be removed. A metal tag is supplied with this wood insert.

When referencing installation or connection to masonry fireplaces or chimneys, the masonry construction must or shall be code complying.

IMPORTANT: Smoke and CO Detectors:

Make sure your home has a working smoke and CO detector, especially near any bedrooms. We recommend having a smoke and CO detector in the same room as the wood appliance for additional safety. Location of both detectors should be chosen wisely to avoid false alarms when reloading the appliance.

Fire Extinguisher:

A fire extinguisher should be installed in the home. The location of the fire extinguisher should be known by all family members.

Installation

Installing Your Insert

SAFETY NOTE: The insert is very heavy and will require two or three people to move it into position. The insert can be made a little lighter by removing the cast iron door by opening it and lifting it off its hinges. Be sure to protect your hearth extension with a heavy blanket or carpet scrap during the installation.

NOTE: You will be required to purchase either the standard or offset 6" diameter (152mm) flue adaptor that is best suited for the specific installation.

List of Tools needed;

- Pull Rod (included with insert)
- 1/2" socket / ratchet
- 3/8 open face wrench

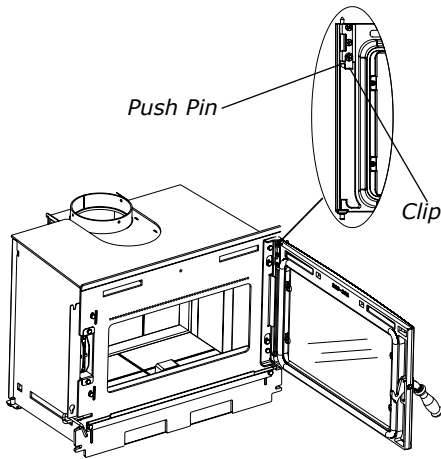

1. Remove the Door to make the insert easier to handle. To remove the door, open fully, remove clip by removing 1 Philips head screw, release the push pin at the top of the door, and lift out from the bottom. See above diagram.

2. Install the required flue adaptor onto the end of the flex liner as shown in diagram 1. Secure the adaptor using 3 screws - 1 on the front, left and right side as shown in Diagram 2.

Alignment of the flue adaptor can be critical during the install, it is recommended that the flex liner be left as compressed as possible. Before inserting the unit the adaptor should hang, when level, slightly above the required height.



Diagram 1 Flex Liner

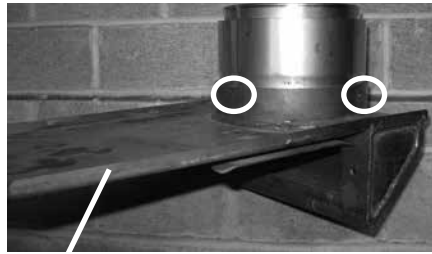

Flue Adaptor Diagram 2

Secure adaptor using 3 screws - 1 in the front and 1 each on the left and right side.

3. Install the unit by first setting the rear of the unit into the fireplace. See Diagram 3. Ensure that the unit is centered in the existing fireplace and lined up with the flue adaptor.
4. Slide the unit back until the flue adaptor is slightly engaged.



Diagram 3

5. At this point it is recommended to level the unit and ensure that the leveling bolts rest on the surface of the fireplace. This will keep the adaptor from binding as the unit is slid into position.
6. Insert the provided pull rod through the hole in the top center of the unit. Secure the threaded end into the flue adaptor as shown in Diagram 4. While sliding the unit into place pull on the rod to ensure that the flue adaptor is properly engaged. See Diagram 5.
7. Ensure that the unit is still level.

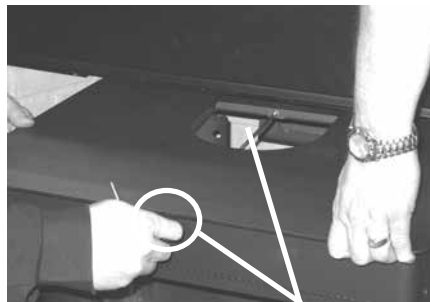

Diagram 4 Pull Rod

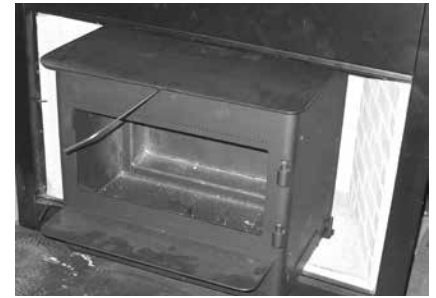

Diagram 5 Pull Rod In Place

8. To complete the installation and to ensure a secure fit and connection of the flue adaptor to the insert, it is essential that the two bolts, flat washers and lock washers (supplied with packaged manual) be installed and tightened using a 1/2" socket as shown in Diagram 6. This prevents the possibility of creosote drip and exhaust gas leakage.

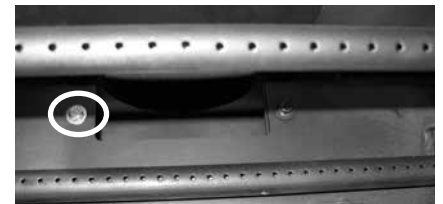

Diagram 6

9. Remove the pull rod from the top center of the fireplace. See Diagram 7.



Diagram 7 Pull Rod

NOTE: The pull rod should not be thrown away. It should be kept if the stove is ever needed to be removed from the fireplace.

10. Re-install the door removed in step 1.

Fan & Cast Faceplate Installation

Stop! Read Carefully.
Enamel & Cast components are very fragile. Use extreme care when handling.

Note: The liner and flue adaptor should be installed prior to reading these instructions.

- 1) With door already removed - place fan in front of unit as shown below, Loosen 2 flange bolts - adjust flange to rest on fan assembly, once height has been determined . Leave 2" between fan and unit, tighten 2 flange bolts using 7/16" open end wrench. Fan assembly can now be secured to the unit using 2 bolts on both left and right side - see Diagrams 1 & 2.

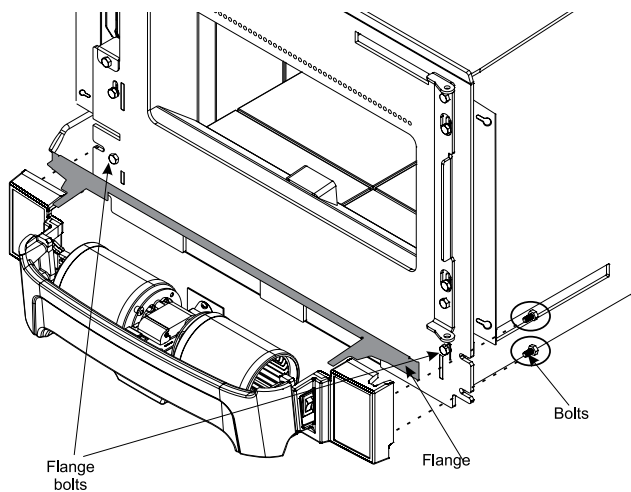
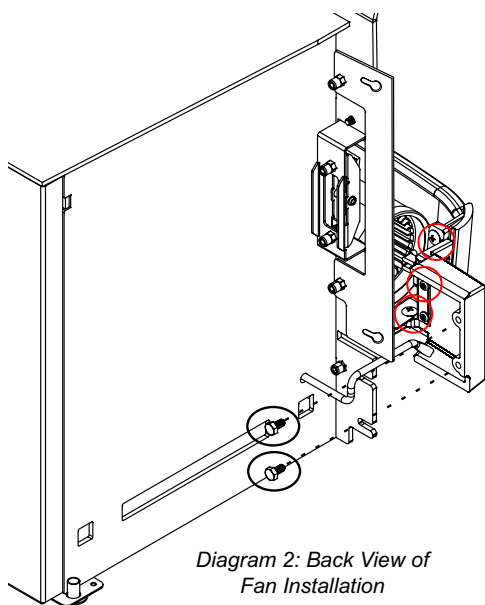

Diagram 1



Note: If screws do not lineup, loosen the 2 screws per side as shown in Diagram 2 and adjust left side and right side facia. Tighten the 2 screws per side and install the fan on the unit.

- 2) Slide the unit into position leaving partially out to allow for installation of the left and right side surrounds.
- 3) Install the left and right side surround to the mounting brackets on the unit using 2 bolts per side. See Diagram 3.

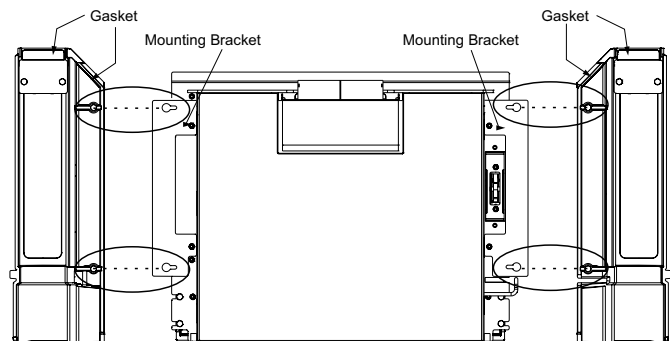

Diagram 3

- 4) Place a strip of gasket on top of the left and right side surround on the front lip of the side castings. See Diagram 3.
- 5) Carefully slide the top surround in place by aligning the mounting plates with the two retainers in the left and right side surrounds. See Diagram 4.

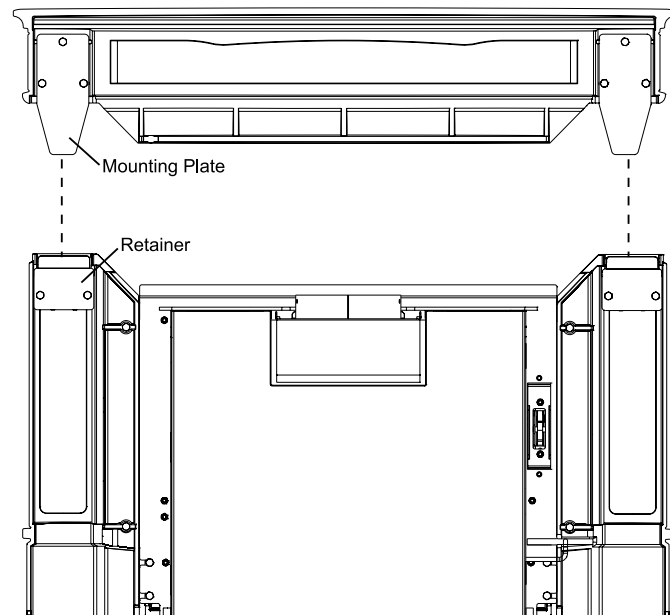

Diagram 4

installation

6) Place ashlip over fan by fitting it onto the flange on the firebox. See Diagram 5 and 6.

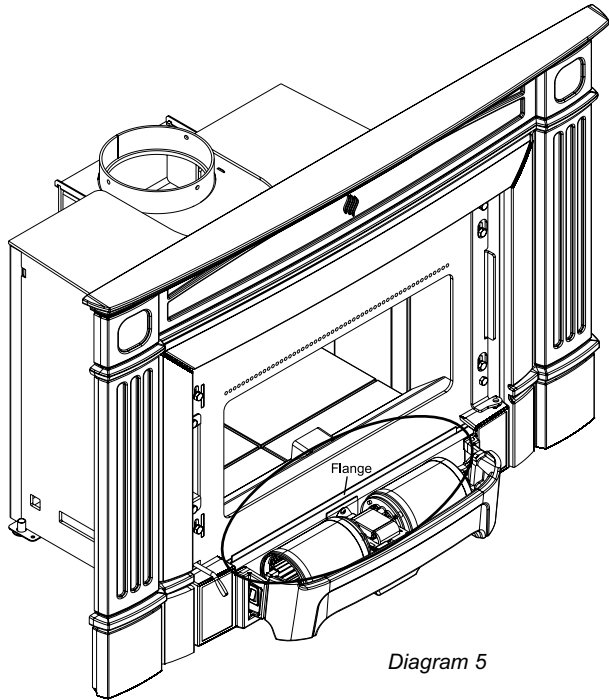

Diagram 5

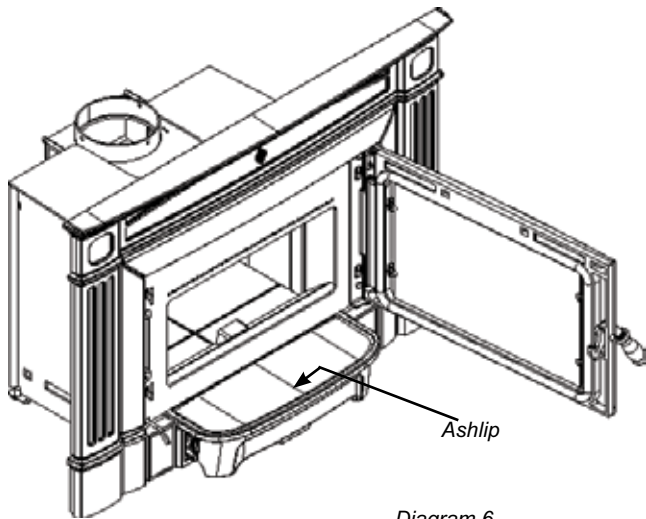

Diagram 6

7) Install door and close with caution - adjustments may be necessary.

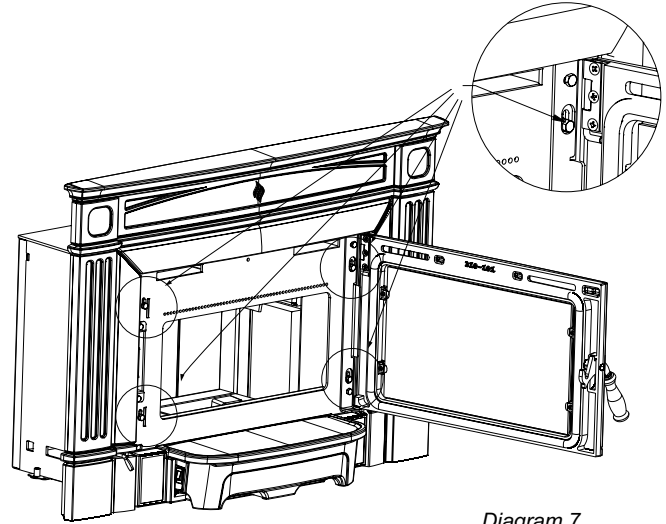

Diagram 7

- 8) Surround adjustments can be made up or down, loosen 4 bolts shown on face of unit (Diagram 7) and adjust. Surround can also be adjusted left or right, loosen 4 bolts shown in Diagram 3 - adjust surround left or right and retighten bolts. Check that gaps around door are even and door closes properly.
- 9) Completely slide unit into place - after all adjustments have been made.

DO NOT ROUTE THE FAN POWER CORD UNDER OR IN FRONT OF THE UNIT.

Do not turn the fan ON until your insert has reached operating temperature or at least 30 minutes after starting fire.

Installer: Please record unit serial number here before installing blower.

Serial No. _____

Brick Installation

Firebrick is included to extend the life of your stove and radiate heat more evenly. Check to see that all firebricks are in their correct positions and have not become misaligned during shipping. Install all firebricks (if bricks were removed at install) per the Diagram below and place in their correct positions. Do not use a grate.



LyTherm Sheet

Order of firebrick install:

- a) Rear Firebrick
- b) Firebox floor - install brick over LyTherm Sheet
- c) Right and left side Firebricks

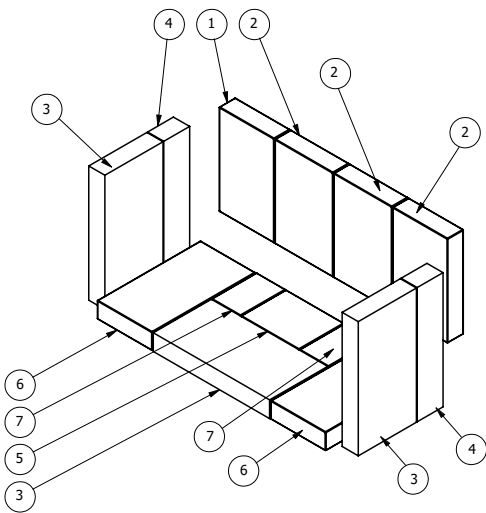

Fire bricks	
#	Size
1	4-1/4" x 7"
2	4-1/2" x 7"
3	9" x 4-1/2"
4	9" x 2"
5	3-1/2" x 4-1/2"
6	4-1/4" x 8"
7	3-1/2" x 2-1/4"

Installation

Baffle Installation

Note: unit in images may not be identical to the HI1150—they depict the process.

1. Open the door.
2. Remove the front secondary air tube with pliers as shown below.

Note: It will be easier to remove the air tubes by removing both the bottom right base brick and right side wall brick.

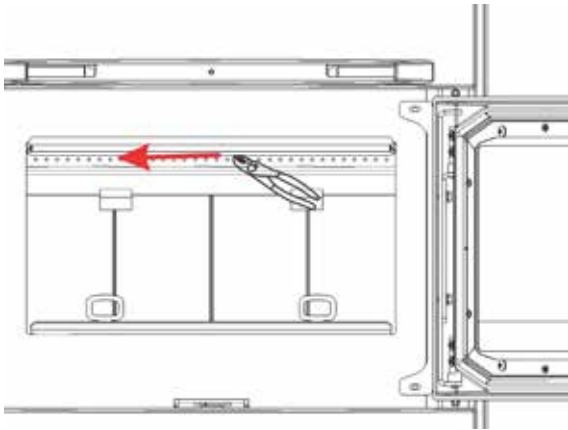

3. Install the center baffle.



Centre Baffle

4. Install the right and left side baffles (right side baffle shown below).

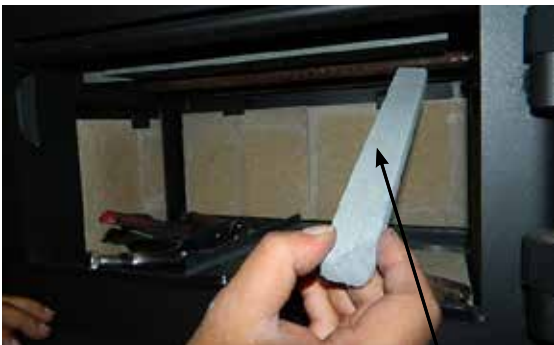

Baffle Bracket

5. Install left and right baffle brackets (installation of left baffle bracket shown below).



Baffle Bracket

6. Reinstall the front air tube.
7. Secure the baffles into position by lifting up on the brick slightly so that the locking bracket slides over the airtube as shown. Repeat step on other side.



Stainless Steel Smoke Deflector Installation

The stainless smoke deflector is located in the upper front area of the firebox. The deflector is held in place with 2 bolts. Prior to the first fire, ensure deflector is seated properly and secured with 2 hand tightened bolts which are accessible from behind the smoke deflector.

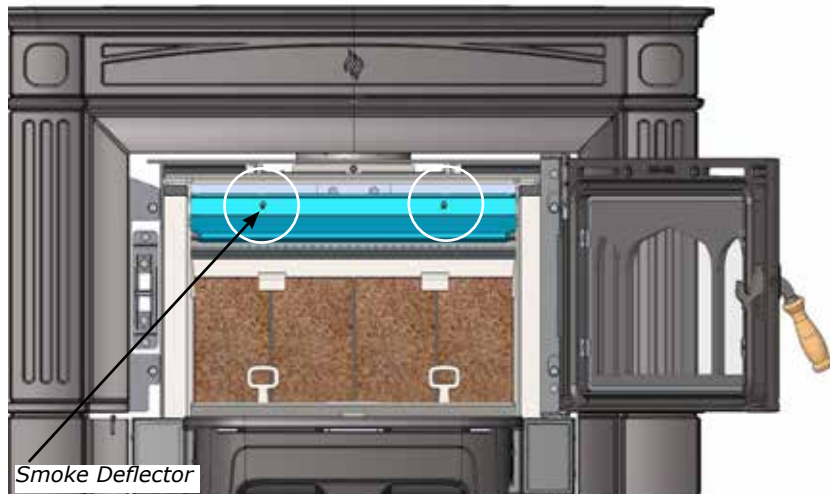

Smoke deflector is installed through the door opening in location shown in Diagram

To replace the deflector, loosen both bolts and slide deflector downward; push deflector to the back wall of the unit and maneuver out. Install new deflector and hand tighten bolts.

Ensure positive location of the deflector prior to hand tightening.

WARNING: Operation of the unit without proper installation of smoke deflector will void warranty.

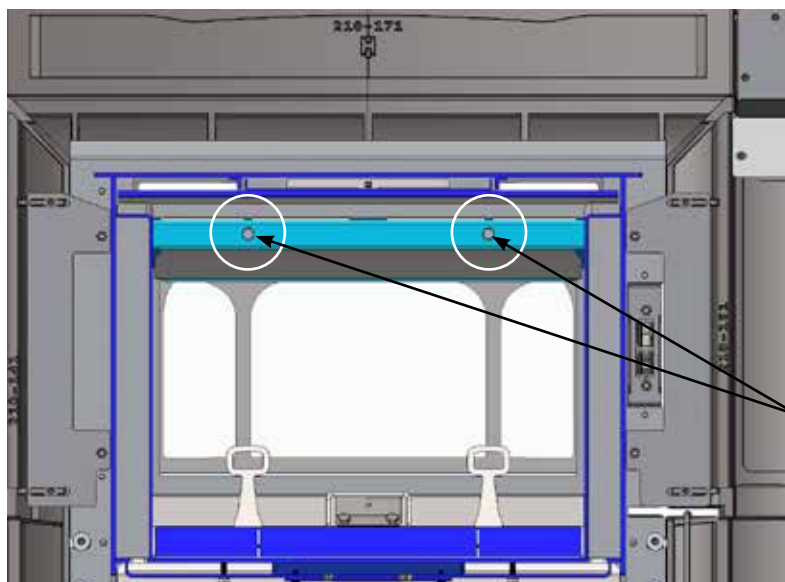

Ensure deflector is seated so bolts are seated at the bottom of the slot before tightening.

Smoke deflector installed with 2 bolts.

Note: *This is a cutaway view from the back of the unit*

operating instructions

Seasoned Wood

Whether you burn wood in a fireplace, stove or insert, good quality firewood is the key to convenience, efficiency and safety. Wet wood and pieces that are not the right size and shape for your wood burner can be frustrating, burn inefficiently and deposit creosote that can fuel a dangerous chimney fire. Good planning, seasoning and storage of the firewood supply are essential to successful wood burning.

- Stack the wood in separate rows in an open location where the summer sun can warm it and breezes can carry away the moisture. Do not stack unseasoned wood tightly in an unvented storage area.
- Do not allow firewood to lie on the ground for more than a couple of days before stacking. Mould and rot can set in quickly.
- Stack the wood up off the ground on poles, lumber rails or pallets.
- The top of the pile can be covered to keep off rain, but do not cover the sides.

Softer woods like pine, spruce and poplar/aspen that is cut, split and stacked properly in the early spring maybe be ready for burning in the fall. Extremely hard woods like oak and maple, and large pieces of firewood, may take a minimum of a full year to dry enough. Drying may also take longer in damp climates

There are a few ways to tell if wood is dry enough to burn efficiently. Use as many indicators as possible to judge the dryness of the firewood your are considering. Here are ways to judge firewood moisture.

- Using a moisture meter, select the species of fuel and then penetrate the pins into a split piece. Ideal moisture and seasoned firewood should be less than 20% moisture content.
- Checks or cracks in the end grain can be an indication of dryness, but may not be a reliable indicator. Some wet wood has checks and some dry wood has no checks.
- The wood tends to darken from white or cream colour to grey or yellow as it dries.
- Two dry pieces banged together sound hollow; wet pieces sound solid and dull.
- Dry wood weighs much less than wet wood.
- Split a piece of wood. If the exposed surface feels damp, the wood is too wet to burn.

Operating Instructions

With your unit now correctly installed and safety inspected by your local authority, you are now ready to start a fire. Before establishing your first fire, it is important that you fully understand the operation of your draft control.

WARNING

Fireplace Stoves equipped with doors should be operated only with doors fully closed. If doors are left partly open, gas and flame may be drawn out of the fireplace stove opening, creating risks from both fire and smoke.

Draft Control

Before establishing your first fire, it is important that you fully understand the operation of draft control. The draft control rod is on the left side of the Insert and it controls the intensity of the fire by increasing or decreasing the amount of air allowed into the firebox. To increase the draft, slide the rod to the left and to decrease the draft, slide the rod to the right.

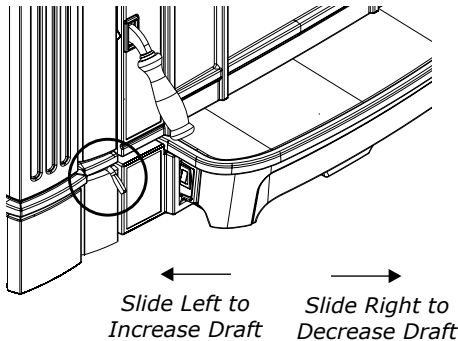

As well as a primary and glass wash air system, the unit has a full secondary draft system that allows air to the induction ports at the top of the firebox, just below the flue baffle.

WARNING: To build a fire in ignorance or to disregard the information contained in this section can cause serious permanent damage to the unit and void your warranty.

First Fire

When your installation is completed and inspected you are ready for your first fire.

THIS UNIT IS DESIGNED TO BURN SEASONED CORDWOOD ONLY. COAL, BRIQUETTES AND ALL OTHERS LISTED ON PAGE 2 ARE NOT APPROVED. SEASONED CORDWOOD SHOULD BE LESS THAN 20% MOISTURE CONTENT.

START UP AND OPERATING PROCEDURES:

1. For the first few days, the wood insert will give off an odour from the paint. This is to be expected as the high temperature paint becomes seasoned. Windows and/or doors should be left open to provide adequate ventilation while this temporary condition exists. Burning the wood insert at a very high temperature the first few times may damage the paint. During the first few fires, keep the combustion rate at a moderate level and avoid a large fire. Only after 5 or 6 such fires can you operate the wood insert at its maximum setting, and only after the metal has been warmed.
2. Do not place anything on the wood insert top during the curing process. This may result in damage to your paint finish.
3. When starting the fire, ensure air control is in the fully open position (far left). Crumble 2-5 pieces of newspaper and add approx. 1lb of kindling stacked in a manner that allows air flow on the firebrick hearth (Tee-pee style or other). **DO NOT USE A GRATE TO ELEVATE THE FIRE.** Light the newspaper and adjust the door if it is slightly ajar for less smoke roll out. Keep the door in that position for 2-3 minutes to establish a good fire.

4. When the fire is well established add another 0.5 - 1 lb kindling along with few pieces of start up cord wood (startup cord wood is slightly larger than kindling but not full pieces of cord wood). keep the door open for 1.5 - 2 min until the fire started well enough then close the door.

CAUTION: Never leave unit unattended if door is left open. This procedure is for fire start-up only, as unit may overheat if door is left open for too long.

5. Once flame has been established, open the door and add another 6 or 7 pieces (2 lbs) of start up cord wood more to the back. Hold door slightly ajar for 30-60 sec to establish flame, and then close the door.

NOTE: These steps are crucial to ensure proper charcoaling and coal bed prior to loading High, Med and Low fire loads.

6. Once this has burned down, open the door, and rake the coals to create a uniform charcoal bed. Load 5 pieces of 17" long cord wood, East-West orientation, with the heaviest pieces at the back of the firebox, and ensure all pieces are behind the log retainers. Do not block the pilot with wood. Once loaded, close the door right away. Burn on high setting (air control to the far left when facing the unit) for 6-10 minutes. Now you can adjust the air control to your desired position. After 15 minutes, the fan can be turned on.

High Fire: Air control to far left.

Low Fire: Air control to far right.

WARNING: Never build a roaring fire in a cold wood insert. Always warm your wood stove up slowly!

7. When re-fueling, always open the primary air damper, load fuel, then wait for at least 10 minutes before adjusting the air to the desired position. This will also minimize any smoking (spilling) back into the room.
8. During the first few days it may be more difficult to start the fire. As you dry out your firebrick and your masonry flue, your draft will increase.
9. For those units installed at higher elevations onto sub-standard masonry fireplaces, drafting problems may occur. Consult an experienced dealer or mason on methods of increasing your draft.
10. Some cracking and popping noises may be experienced during the heating up process. These noises will be minimal when your unit reaches temperature.
11. All fuel burning appliances consume oxygen during operation. It is important that you supply a source of fresh air to your unit while burning. A slightly opened window is sufficient for the purpose. If you also have another fireplace in your home, a downdraft may be created by your Regency wood insert causing a draft down your chimney. If this occurs, slightly open a window near your unit.

WARNING: If the body of your unit, or any part of the chimney connector starts to glow, you are over firing. Stop loading fuel immediately and close the draft control until the glow has completely subsided.

12. Green or wet wood is not recommended for your unit. If you must add wet or green fuel, open the draft control fully until all moisture has been dispersed by the intense fire. Once all moisture has been removed, the draft control may be adjusted to maintain the fire.
13. The controls of your unit or the air supply passages should not be altered to increase firing for any reason.
14. If you burn the unit too slowly or at too low a setting your unit will not be operating as efficiently as it can. An easy rule of thumb says that if your glass is clean, then your flue is clean and your exhaust is clean. Burn the insert hot enough to keep the glass clean, and you won't need to clean your flue as often.

How to Light & Maintain a Wood Stove Fire



operating instructions

Fan Operation

The fan is to be operated only with the draft control rod **pulled out at least 1/2" from the fully closed position**. The fan is not to be operated when the draft control rod is in the closed position (pushed in). The fully closed position is the low burn setting.

The fan must not be turned on until a fire has been burning for at least 30 minutes. Also note it is recommended that the fan be turned off before each fuel loading and again wait for 30 minutes before the fan is turned on again. This is to allow the stove to reach it's optimum temperature.

To operate fan automatically, push switch on the right side of fan housing to "Auto" and second switch, on the left to either "High" or "Low" for fan speed. The automatic temperature sensor will engage the blower when the unit is at temperature and will shut off the blower once the fire has gone out and the unit has cooled to below a useful heat output range.

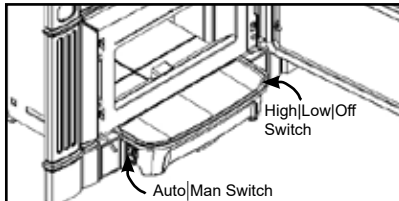

Fan Control Location



To manually operate the fan system, push the switch on the left to "Man" and switch on the right to either "high" or "Low". This will bypass the sensing device and allow full control of the fan. Switching from "Auto" to "Manual" or "High" to "Low" may be done at any time.

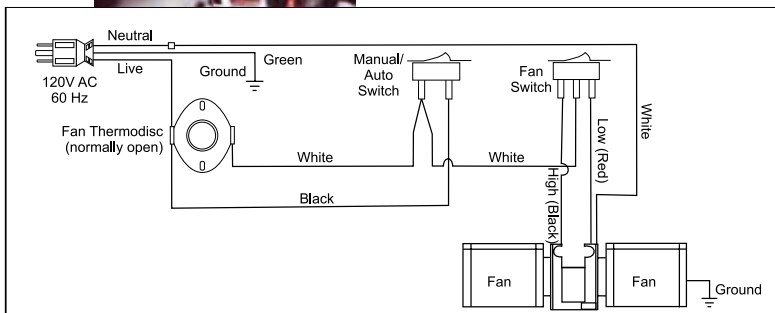

Fan Wiring Diagram

Ash Disposal

During constant use, ashes should be removed every few days.

Ashes should be placed in a metal container with a tight-fitting lid. The closed container of ashes should be placed on a noncombustible floor or on the ground, well away from all combustible materials, pending final disposal. If the ashes are disposed of by burial in soil or otherwise locally dispersed, they should be retained in the closed container until all cinders have thoroughly cooled.

Safety Precautions

1. Do not allow ashes to build up to the loading doors! Only remove ashes when the fire has died down. Even then, expect to find a few hot embers.
2. Please take care to prevent the build-up of ash around the start-up air housing located inside the stove box, under the loading door lip.
3. Never start a fire if the ash plug and ash drawer are not in place. This will cause over firing which can cause excessive warping of the stove. Evidence of over firing can void the warranty on your stove.
4. The firebricks are brittle and can be damaged if the plug is replaced carelessly or pieces that are too large are forced through the hole.

Safety Guidelines and Warnings

CAUTION: do not use chemicals as fluids to start fire.

1. **CAUTION:** Never use gasoline, gasoline type lantern fuels, kerosene, charcoal lighter fuel, or similar liquids to start or 'freshen up' a fire in your heater. Keep all such liquids well away from the heater while it is in use.
2. Keep the door closed during operation and maintain all seals in good condition.
3. Do not burn any quantities of paper, garbage, and never burn flammable fluids such as gasoline, naphtha or engine oil in your stove.
4. If you have smoke detectors, prevent smoke spillage as this may set off a false alarm.
5. Do not overfire heater. If the chimney connector, flue baffle or the stove top begin to glow, you are over firing. Stop adding fuel and close the draft control. Over firing can cause extensive damage to your stove including warping and premature steel corrosion. Over firing will void your warranty.

6. Do not permit creosote or soot build-up in the chimney system. Check and clean chimney at regular intervals. Failure to do so can result in a serious chimney fire.
7. Your Regency stove can be very hot. You may be seriously burned if you touch the stove while it is operating, keep children, clothing and furniture away. Warn children of the burn hazard.
8. The stove consumes air while operating, provide adequate ventilation with an air duct or open a window while the stove is in use.
9. Do not connect this unit to a chimney flue serving another appliance.
10. Do not use grates or andirons or other methods for supporting fuel. Burn directly on the bricks.
11. Open the draft control fully for 10 to 15 seconds prior to slowly opening the door when refuelling the fire.
12. Do not connect your unit to any air distribution duct.
13. This heater is designed to burn natural wood only. Higher efficiencies and lower emissions generally result when burning air dried seasoned hardwoods, as compared to softwoods or to green or freshly cut hardwoods.
14. In the event of component failure, replace parts with only Regency listed parts.
15. Warning: do not abuse glass door such as striking or slamming shut.

CAUTION: DO NOT BURN GARBAGE OR FLAMMABLE LIQUIDS SUCH AS GASOLINE, NAPHTHA OR ENGINE OIL. SOME FUELS COULD GENERATE CARBON MONOXIDE AND ARE VERY DANGEROUS.

CAUTION: DO NOT CONNECT TO, OR USE IN CONJUNCTION WITH ANY AIR DISTRIBUTION DUCT WORK UNLESS SPECIFICALLY APPROVED FOR SUCH INSTALLATION.

CAUTION: HOT WHILE IN OPERATION. KEEP CHILDREN, CLOTHING AND FURNITURE AWAY. CONTACT MAY CAUSE SKIN BURNS.

DO NOT BURN:

- Treated wood
- Coal
- Garbage
- Cardboard
- Solvents
- Colored Paper
- Trash
- Salt drift wood
- Cut lumber, plywood, mill ends.

Burning treated wood, garbage, solvents, colored paper or trash may result in release of toxic fumes. Burning coal, cardboard, or loose paper can produce soot, or large flakes of char or fly ash, causing smoke spillage into the room.



maintenance

Maintenance

It is very important to carefully maintain your fireplace stove, including burning seasoned wood and maintaining a clean stove and chimney system. Have the chimney cleaned before the burning season and as necessary during the season, as creosote deposits may build up rapidly. Moving parts of your stove require no lubrication.

Creosote

When wood is burned slowly, it produces tar and other organic vapours combine with moisture to form creosote. The creosote vapours condense in the relatively cool chimney flue of a slow burning fire. As a result, creosote residue accumulates on the flue lining. When ignited, this creosote can result in an extremely hot fire.

The chimney connector and chimney should be inspected at least once every two months during the heating season to determine if creosote build up has occurred. If creosote has accumulated it should be removed to reduce the risk of chimney fire.

CAUTION: Things to remember in case of a chimney fire:

1. Close all draft controls.
2. CALL THE FIRE DEPARTMENT.

Ways to Prevent and Keep Unit Free of Creosote

1. Burn stove with the draft control wide open for about 10-15 minutes every morning during burning season.
2. Burn stove with draft control wide open for about 10 - 15 minutes every time you apply fresh wood. This allows the wood to achieve the charcoal stage faster and burns up any unburned gas vapours which might otherwise be deposited within the system.
3. Only burn seasoned wood! Avoid burning kiln dried, wet or green wood. Seasoned wood has been dried at least one year.
4. A small hot fire is preferable to a large smouldering one that can deposit creosote within the system.
5. The chimney and chimney connector should be inspected at least once every two months during the heating season to determine if a creosote buildup has occurred.
6. Have chimney system and unit cleaned by competent chimney sweeps twice a year during the first year of use and at least once a year thereafter or when a significant layer of creosote has accumulated (3 mm / 1/8" or more) it should be removed to reduce the risk of a chimney fire.

Wood Storage

Store wood under cover, such as in a shed, or covered with a tarp, plastic, tar paper, sheets of scrap plywood, etc., as uncovered wood can absorb water from rain or snow, delaying the seasoning process.

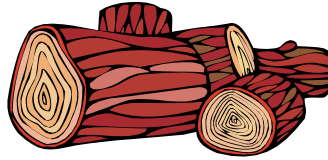

Fan Maintenance

Note: Ensure the 3-prong plug is disconnected prior to servicing the fan.

As the sealed bearings are lubricated, there is no need to lubricate them further. Extra lubricant will cause more lint and dust buildup, causing the bearings to fail prematurely.

Regular cleaning and vacuuming of the fan area will prolong the life of the motor.

TO REMOVE THE FAN, FOLLOW THE STEPS BELOW.

1. Remove the door. To remove the door, open fully, remove clip by removing 1 Philips head screw, release the push pin at the top of the door and lift out from the bottom. See diagram below.

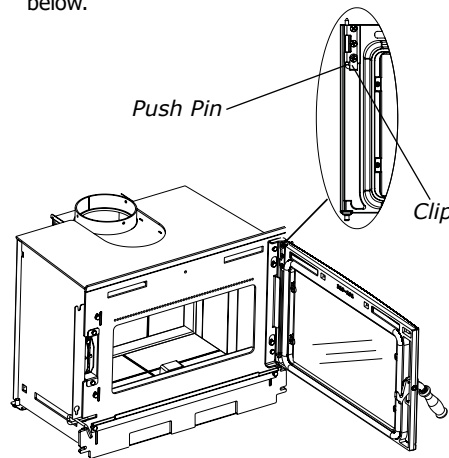

2. Remove the ashlip by lifting it up and out, and put it aside.

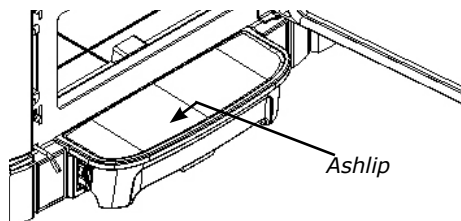

3. Remove bolts as indicated in diagram #3.

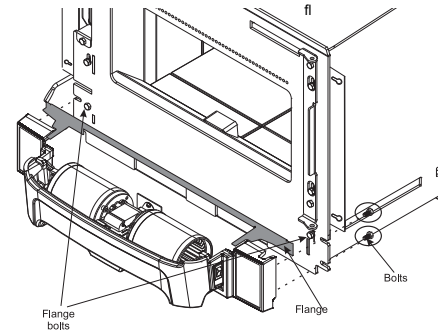

4. Remove fan and clean as required.
5. If the fan motor needs to be replaced ensure to **Label all wires prior to disconnection when servicing controls. Wiring errors can cause improper and dangerous operation.**

Door Gasket

If the door gasket requires replacement, 7/8" diameter material must be used. A proper high temperature gasket adhesive is required. A gasket repair kit, Part # 846-570 is available from your local Hampton dealer.

Glass Cleaning

Only clean your glass window when it is cool. Your local retailer can supply you with special glass cleaner if plain water and a soft cloth does not remove all deposits.

Door Removal

When handling enamel parts, please handle with care as they can be damaged.

- 1) Open door fully.
- 2) Remove clip by removing one Philips head screw.
- 3) Release the push pin at the top of the door and slide out while lifting up and out from the bottom.

Please be careful when removing the Door and do not drop onto the Ashlip, it may chip.

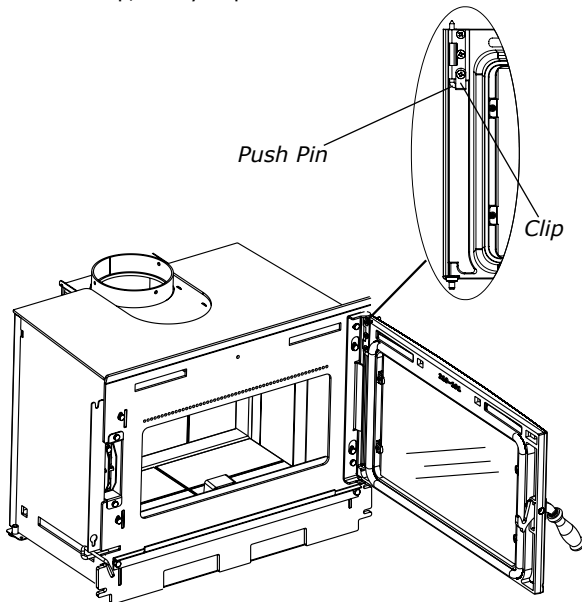

DOOR INSTALLATION NOTE
 After re-installing the door, carefully swing open and check the clearance to the Right Hand Cast Side. If tight or rubbing, loosen the 7/16 nuts and adjust the clearance and then re-tighten.

Glass Replacement

- 1) Remove door from unit.
- 2) To replace the glass remove the 4 screws highlighted in the diagram below.
- 3) Lift off the glass retainer and carefully remove the glass.
- 4) Place new glass in the door, make sure that the glass gasketing will properly seal your unit.
- 5) Re-install the glass retainer. Ensure that it rests on the gasket and not the glass.
- 6) Secure glass retainer using the 4 screws. Do not wrench down on the glass as this may cause the glass to break.
- 7) Place door back on unit.

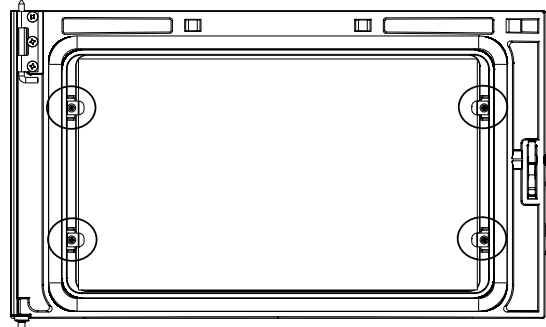

Remove 4 screws

Avoid impact on glass doors such as striking or slamming shut.

Handle Replacement

- 1) Remove handle by turning it counter clockwise.
- 2) Fit new door handle over door latch and secure.
 - To assemble handle:
 - a) Place spacer over handle threads.
 - b) Screw handle into door latch.

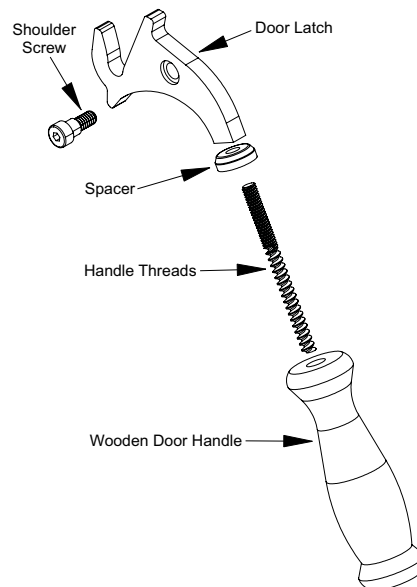

maintenance

Latch Adjustment

The door latch or door alignment may require adjustment as the door gasket material compresses after a few fires. Removal of spacers will allow the latch to be moved closer to the door frame, causing a tighter seal and the ability to raise or lower the latch assembly.

- 1) Raise or lower the latch by undoing the inner 2 bolts. Adjust to desired location and retighten the 2 bolts, make sure the door catch closes freely and makes a good seal. Do a paper test to confirm seal.

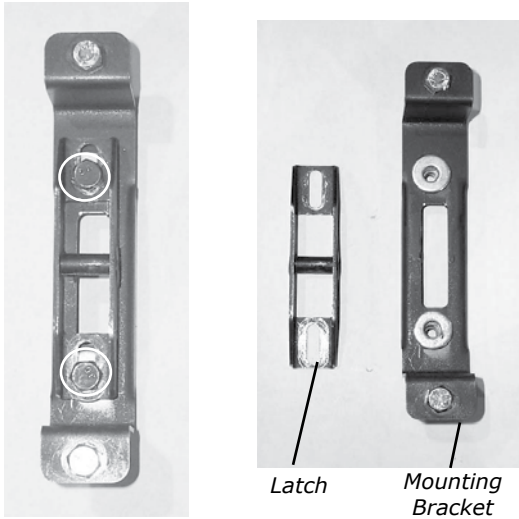

- 2) For door gasket seal, remove the latch assembly from the unit by undoing the outer 2 bolts.

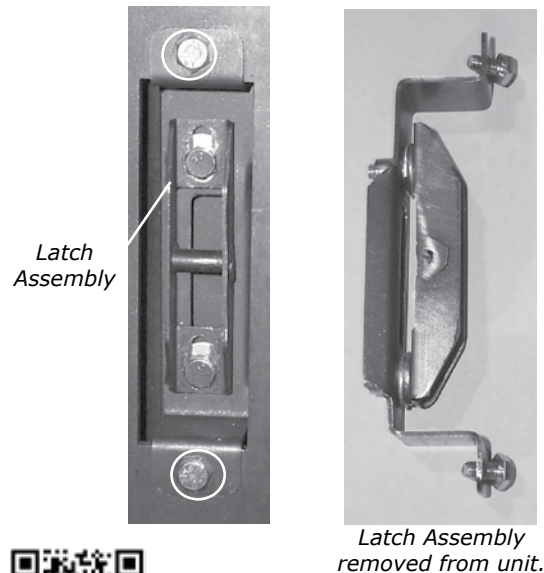

- 3) Remove necessary amount of spacers sitting on the mounting bracket. Ensure an equal amount of spacers are removed from both top and bottom.

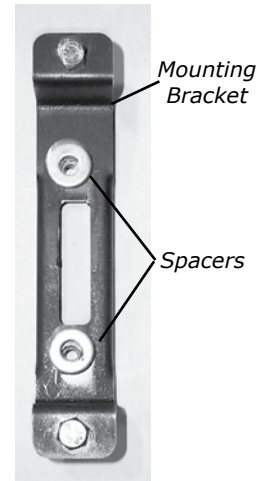

- 4) Re-secure latch to mounting bracket using 2 bolts.



Latch Assembly re-assembled with Spacers removed.

- 5) Re-secure the latch assembly to the unit using 2 bolts. Confirm proper location of the door catch so that it closes tight, freely.



Secondary Air Tube Removal / Installation

1. Allow the stove to burn out and cool down, until cool to touch.
2. Open stove door to access secondary air tubes.

Note: to make it easier to remove the air tubes, first remove both the bottom right base brick and right side wall brick.

5. To reinstall or replace, first slide left side of tube into hole on left side air channel. Align tab on right side air channel with notch on right hand end of air tube. Firmly grip center of air tube with vise grips, use hammer to tap vise grips from left to right until the tube bottoms out into the air channel on right.

Note : If air tube is locked into place correctly there should be slight movement when moving the air tube back and forth.

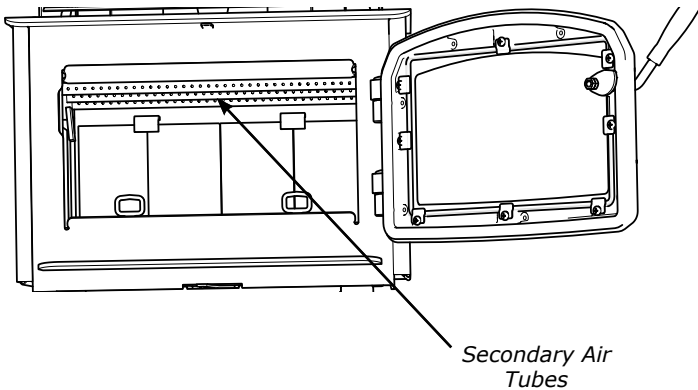

3. Grasp front secondary air tube firmly with vise grips, using a hammer tap vise grips from right to left until air tube is released from grip. Remove. See Diagram 1.
4. Remove top left and right metal retainers, followed by the fragile three piece C-Cast Baffles, then remove the remaining 2 tubes.

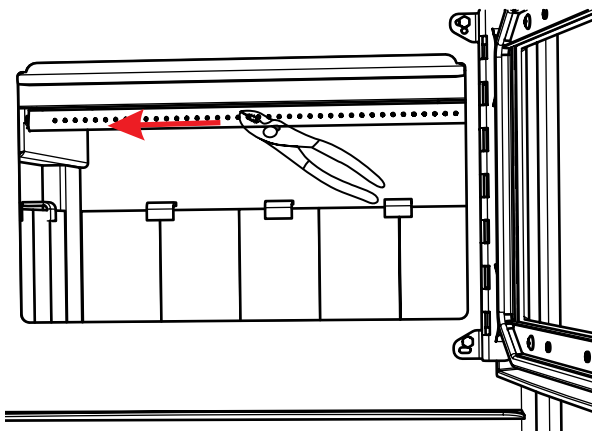
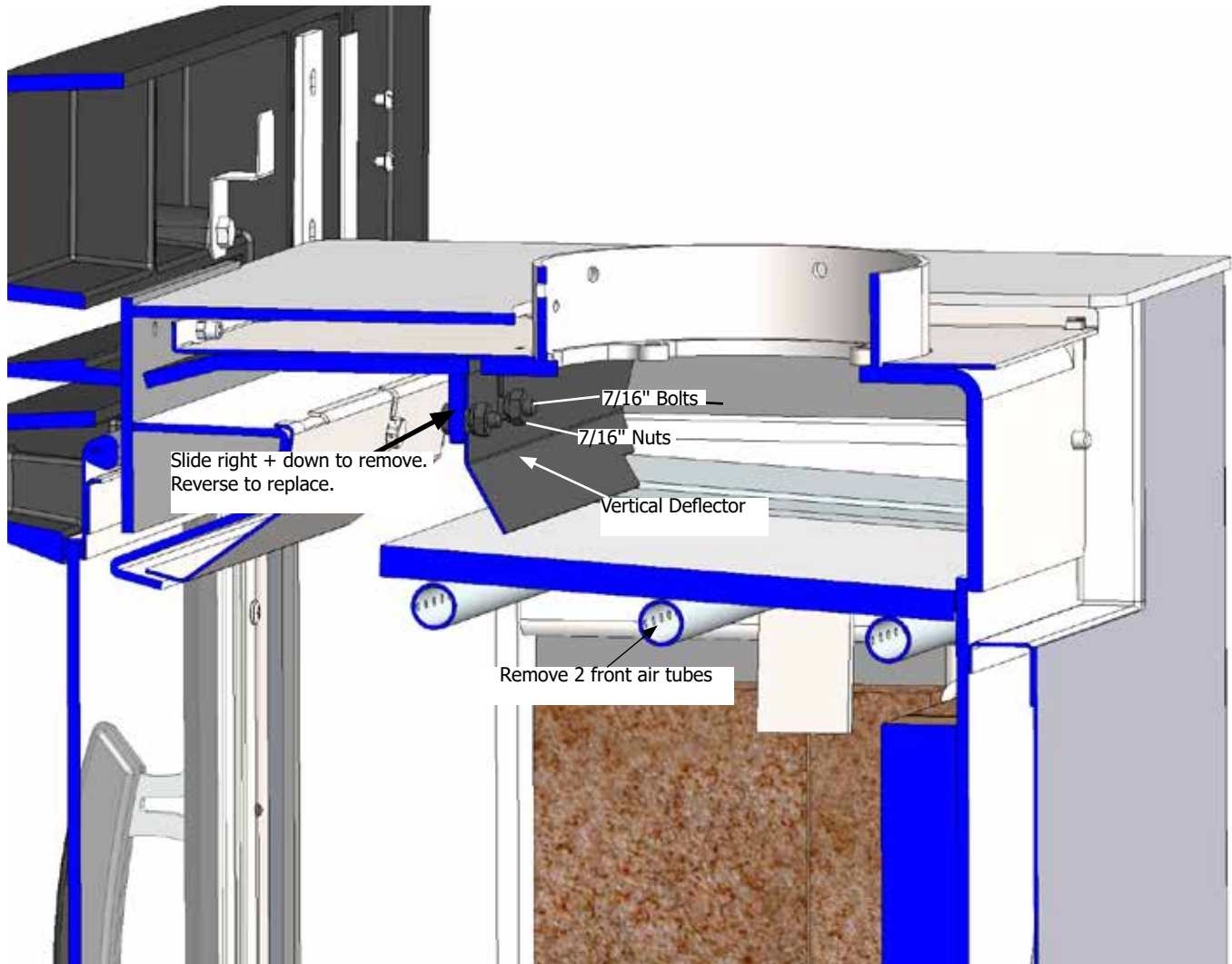

Diagram 1

maintenance

Vertical Stainless Deflector Replacement



1. Remove 2 front secondary air tubes / vermiculite baffles (see manual for details).
2. Loosen the two 7/16" bolts + nuts to remove / replace vertical baffle.
3. Repeat steps to install new vertical deflector.

NOTE: ENSURE BAFFLE IS PUSHED UP AS FAR AS POSSIBLE. TIGHT TO TOP OF FIREBOX.

Annual Maintenance	
Completely clean out entire unit	Annually
Inspect air tube and bricks	Replace any damaged parts.
Adjust door catch assembly	If unable to obtain a tight seal on the door - replace door gasket seal. Readjust door catch after new gasket installed.
Inspect condition and seal of: Glass Gasket Door Gasket	Perform paper test - replace gasket if required
Paper Test	Test the seal on the loading door with a paper bill. Place a paper bill in the gasket area of the door on a cold stove. Close the door. Try to remove the paper by pulling. The paper should not pull out easily, if it does, try adjusting the door latch, if that doesn't solve the problem replace the door gasket.
Check and lubricate door hinge + latch	Use only high temperature anti seize lube. (ie. never seize)
Check glass for cracks	Replace if required.
Clean blower motor	Disconnect power supply. Remove and clean blower. *DO NOT LUBRICATE*
Inspect and clean chimney	Annual professional chimney cleaning recommended.

NOTE:

Chimney Cleaning

When cleaning the chimney system the air tubes, baffles should be removed for ease of cleaning. See manual for details on removal. We highly recommend that the chimney cleaning be done by a professional as they will have the necessary tools such as a proper sized brush and special vacuum cleaner designed to deal with fine particles.

IMPORTANT:

Before attempting to loosen or remove any screw, bolt from the interior of a wood stove, insert or factory built fireplace that has had a fire burned in it, we highly recommend to liberally spray the screw/bolt with a good-quality penetrating oil, one that does not have flammable properties contained within the penetrating oil being used. Allow it to set, then tap or vibrate the screw or bolt to help loosen it before attempting to remove it. For best results, follow the instructions that are provided with the penetrating oil.



parts list

	Part	Description
1	075-037	SS Smoke Deflector
2	075-041	Baffle Holder (Each)
3	033-953	Air Tubes (Each)
4	075-955	Baffle Set Complete
5	075-040	Side Baffle Cover (Each)
6	172-032/P	Vertical Deflector
7	172-942	Flue Adapter Standard
7	172-946	Flue Adapter Offset
8	075-063F	Andiron (Each)
9	075-062	Primary Air Cover Plate
10	075-064	Andiron Bracket (Each)
11	948-163	Cane Bolt Latch
12	*	Screws - 10-24 x 3/8"
13	210-554	Glass Retainer Clips / Screws (set of 4)
14	940-356/P	Glass - Replacement (Includes Glass Gasket)
15	846-686	8 mm Soft Fibre Black Gasket Tape (8') (936-238)
16	948-467	Hinge Pin Lower
17	210-561	Door Assembly Metallic Black (no glass)

	Part	Description
	210-565	Door Assembly Timberline Brown (no glass)
	846-570	Med. Density Door Gasket Kit
18	948-179/P	Black Varnish Wooden Handle
19	210-550	Door Handle Assembly
20	*	Left Side Fan Fascia
21	*	Right Side Fan Fascia
22	*	Front Fan Fascia
23	210-911	Fan / Blower Assembly (Metallic Black)
	210-915	Fan / Blower Assembly (Timberline Brown)
	910-157/P	Blower/Fan Motor
	910-684	Power Cord (120 Volts)
	910-142	Fan Thermodisc
	910-140	Fan Speed Switch - HI/OFF/LOW (3-way)
	910-138	Switch - Auto/Manual (2-way)
24	210-111	Ashlip Metallic Black
	210-115	Ashlip Timberline Brown

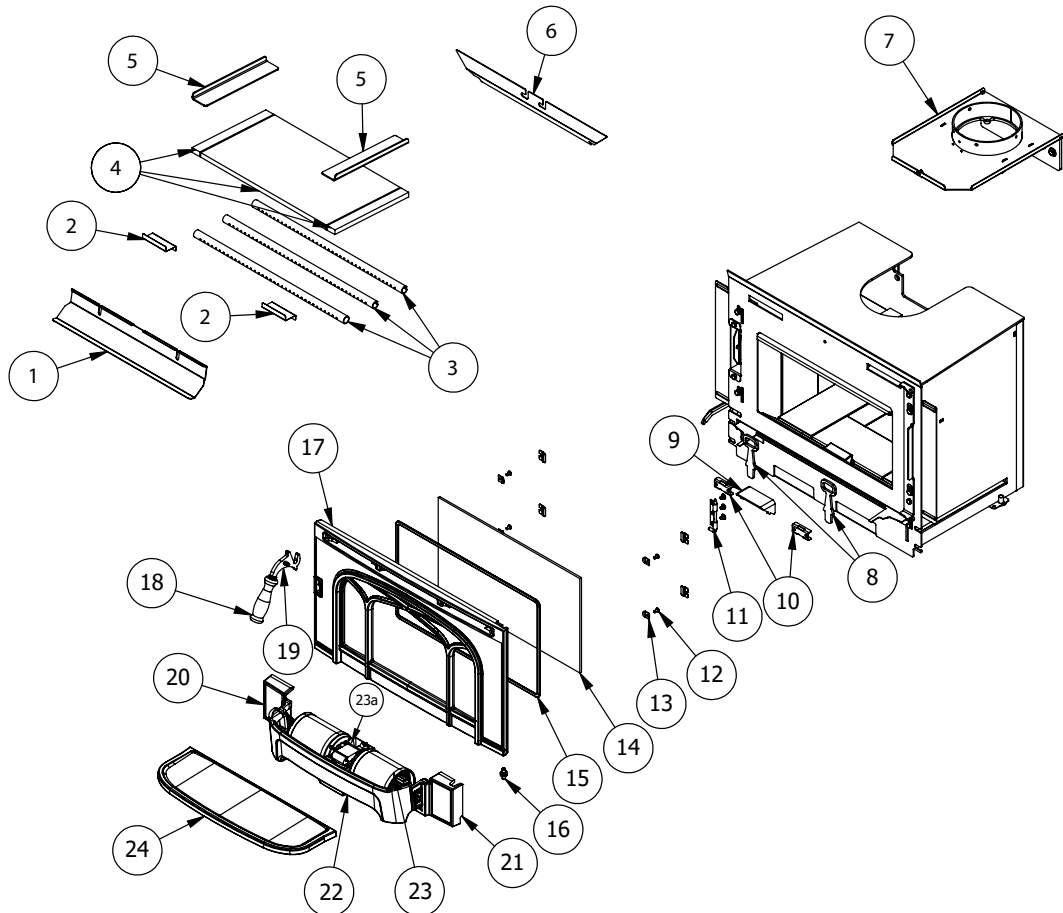

Cast Faceplate

Part #	Description
210-921	Metallic Black Faceplate
210-925	Timberline Brown Faceplate

- 1) * Top Surround
- 2) * Left Side Surround
- 3) * Right Side Faceplate

* Not available as a replacement part.

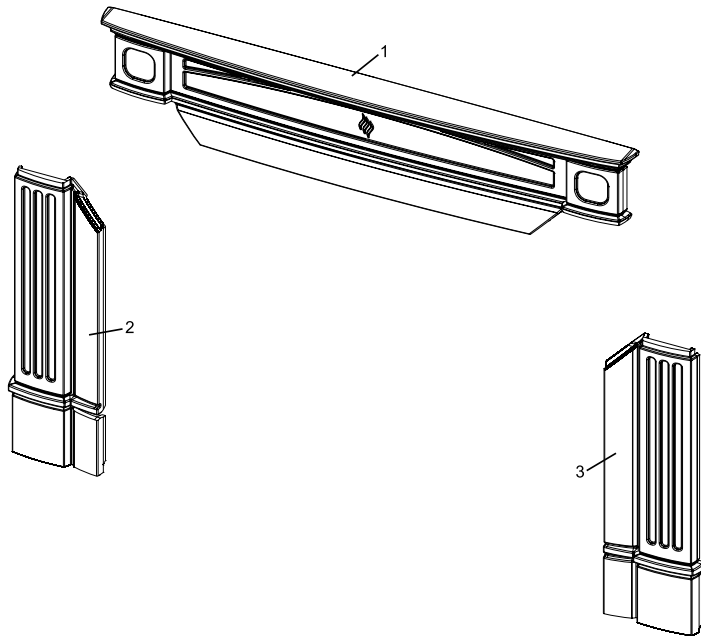

Brick Panels

075-960 HI1150 Brick Kit Complete

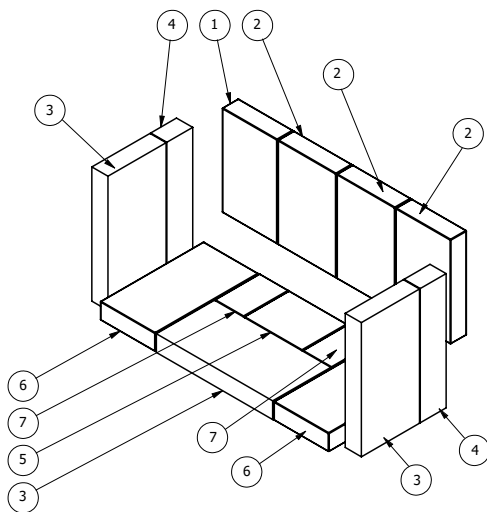

Fire bricks	
#	Size
1	4-1/4" x 7"
2	4-1/2" x 7"
3	9" x 4-1/2"
4	9" x 2"
5	3-1/2" x 4-1/2"
6	4-1/4" x 8"
7	3-1/2" x 2-1/4"

warranty

Indoor Wood Product Warranty

Limited Lifetime Warranty

FPI Fireplace Products International Ltd. (for Canadian customers) and Fireplace Products U S, Inc. (for US customers) (collectively referred to herein as “FPI”) extends this Limited Lifetime Warranty to the original purchaser of this Appliance provided the product remains in the original place of installation. The items covered by this Limited Lifetime Warranty and the period of such coverage are set forth in the table below.

An Appliance in this policy is defined as an Indoor wood insert or Indoor wood freestanding stove.

This Appliance has only been certified and listed for use indoors.

Note: This Wood Product Warranty does not apply to the Ri50 & CF780 models. See Ri50/CF780 policy for specific warranty details.

This Limited Lifetime Warranty starts on the day the Appliance was purchased.

The Limited Lifetime Warranty is not transferable, amendable or negotiable under any circumstances.

Indoor Wood Products	Component Coverage					Subsidized Labor Coverage*** (Years)
	Limited Lifetime	5 years	2 years	1 year	Warranty	
Welded Firebox Steel	✓					5
All Stainless Steel Components, Smoke Deflectors, Heat Shields etc.	✓					3
Air Tubes	✓					3
Airmate	✓					3
Door handle and latch assembly, all hardware	✓					3
Glass Thermal Breakage Only	✓					3
Steel Faceplates, Accessory Housings	✓					3
All Plating	✓					3
Ash Drawer, Heatshields, Pedestal	✓					0
All Baffles, Steel, Ceramic, Vermiculite C-Baffles	✓					0
All castings, firebox, surrounds, doors, panels etc.		✓				3
All Electrical, Blower, wiring, switches, Catalytic Monitors, Probes, etc.			✓			2
Glass - Crazing				✓		1
Catalyst Combustor					**10 Years Prorated	0
Venting/Chimney				✓		1
Screens				✓		1

**See specific warranty details regarding the catalyst combustor in this manual.

Note: Warranty coverage noted above may not be applicable as components/options vary based on appliance purchased.

Conditions:

Warranty protects against defect in manufacture or FPI factory-assembled components only, unless herein specified otherwise.

*****This warranty does not cover dealer travel costs, mileage, fuel, tolls for diagnostic or service work. All labor rates paid to authorized dealers are subsidized, pre-determined rates. Dealers may charge you for travel and additional time beyond their subsidy.**

Any part(s) found to be defective during the warranty period as outlined above will be repaired or replaced at FPI’s option through an accredited distributor, dealer or pre-approved and assigned agent provided that the defective part is returned to the distributor, dealer or agent for inspection if requested by FPI. Alternatively, FPI may, at its own discretion, fully discharge all of its obligations under warranty by refunding the verified purchase price of the product to the original purchaser. The purchase price must be confirmed by the original Bill of Sale.

The authorized selling dealer, or an alternative authorized FPI dealer if pre-approved by FPI, is responsible for all in-field diagnosis and service work related to all warranty claims. FPI is not responsible for results or costs of workmanship of unauthorized FPI dealers or agents in the negligence of their service work.

At all times, FPI reserves the right to inspect reported in the field/on location complaints of products claimed to be defective before processing or authorizing any claim. Failure to allow this upon request will void the warranty.

All warranty claims must be submitted by the dealer servicing the claim, including a copy of the Bill of Sale (proof of purchase by you). All claims must be complete and provide full details as requested by FPI to receive consideration for evaluation. **Incomplete claims may be rejected.**

Replacement Appliances to the original purchaser are limited to one per warranty term. Air tube and baffle replacements are limited to one replacement per warranty term.

The Appliance must be installed according to all manufacturers' instructions as per the manual. All Local and National required codes must be met.

The installer is responsible for ensuring the Appliance is operating as designed at the time of installation.

The original purchaser is responsible for the annual maintenance of the Appliance, as outlined in the owner's manual. As outlined below, the warranty may be voided due to problems caused by a lack of maintenance.

Purchased parts: Repair/replacement parts purchased by the consumer from FPI after the original coverage has expired on the Appliance will carry a **90-day** warranty from the purchase date, valid with a receipt only. Any item shown to be defective will be repaired or replaced at our discretion. No labor coverage is included with these parts.

If freight damage has been found either externally or internally, the dealer must be informed within 3 days. All claims as a result of damage must be submitted by the dealer servicing the claim, including a copy of the Bill of Sale (proof of purchase). All claims must be complete and provide full details as requested by FPI to receive consideration for evaluation. **Incomplete claims may be rejected.**

As this is a Limited Lifetime Warranty, if the Appliance needs to be replaced, the Appliance that was purchased at the time of sale might not be replaced with exactly the same model Appliance. In that case, FPI will replace your Appliance with one that is similar at the time of replacement under the terms of this Limited Lifetime Warranty, but **ONLY** in the event that an item covered by the Limited Lifetime Warranty is found to be defective. Please refer to the table on first page of this warranty for items covered by the Limited Lifetime Warranty. Product changes might be the result of the original Appliance being discontinued, changes in regulatory requirements, product advancements, etc., which are beyond the control of FPI. **This Limited Lifetime Warranty does not cover any installation costs, or costs associated with changes of required clearances for the replacement Appliance, hearth pads, mantles, facing and/or facing materials such as framing, completed walls made of drywall, wood, non-combustible board, tile, brick, stone, marble etc., venting/chimney systems, or components of the chimney system.**

If a suitable replacement is not available, FPI will refund **50%** of the purchase price of the Appliance and any applicable FPI accessories (faceplates, brick panels, media, etc.) purchased at the time of sale. **In no event will FPI refund any portion of the purchase price of, or reimburse costs associated with, any other items, including without limitation, installation of a new unit, changes of required clearances for a new unit, hearth pads, mantles, facing and/or facing materials such as framing, completed walls made of drywall, wood, non-combustible board, tile, brick, stone, marble etc., venting/chimney systems, or components of the chimney system. A copy of the receipt or bill of sale will be necessary to validate the purchase price.**

Exclusions:

This Limited Lifetime Warranty does not extend to paint, rust or corrosion of any kind due to a lack of maintenance or improper venting, combustion air provision, corrosive chemicals (i.e. chlorine, salt, air, etc.), firebrick (rear, sides or bottom), door or glass gasketing, vermiculite floor bricks, andiron assemblies/flue damper rod or any other additional factory fitted gasketing, batteries.

Malfunction, damage or performance-based issues as a result of environmental conditions, location, chemical damages, downdrafts, installation error, an installation by an unqualified installer, incorrect chimney components (including but not limited to cap size or type), operator error, abuse, misuse, use of improper fuels (such as unseasoned cordwood, mill-ends, construction lumber or debris, off-cuts, treated or painted lumber, metal or foil, plastics, garbage, solvents, cardboard, coal or coal products, oil-based products, waxed cartons, compressed pre-manufactured logs, kiln dried wood), lack of regular maintenance and upkeep, acts of God, weather-related problems from hurricanes, tornados, earthquakes, floods, lightning strikes/bolts or acts of terrorism or war, which result in a malfunction of the Appliance are not covered under the terms of this Limited Lifetime Warranty.

warranty

FPI has no obligation to enhance or modify any Appliance once manufactured (i.e. as products evolve, field modifications or upgrades will not be performed on existing Appliances).

Any Appliance showing signs of neglect or misuse will not be covered under the terms of this warranty policy and may void this warranty, including Appliances with rusted or corroded fireboxes that have not been reported as rusted or corroded within **three (3)** months of installation/purchase.

Appliances which show evidence of being operated while damaged, or with problems known to the purchaser and causing further damages will void this warranty.

Appliances where the serial no. has been altered, deleted, removed or made illegible will void this warranty.

Minor movement, expansion and contraction of the steel is normal and is not covered under the terms of this warranty.

Freight damages for products or parts are not covered under the terms of the warranty.

Products made or provided by other manufacturers and used in conjunction with the FPI Appliance without prior authorization from FPI may void this warranty.

Limitations of Liability:

The original purchaser's exclusive remedy under this warranty, and FPI's sole obligation under this Limited Lifetime Warranty, express or implied, in contract or in tort, shall be limited to replacement, repair, or refund, as outlined above. IN NO EVENT WILL FPI BE LIABLE UNDER THIS WARRANTY FOR ANY INCIDENTAL OR CONSEQUENTIAL COMMERCIAL DAMAGES OR DAMAGES TO PROPERTY. TO THE EXTENT PERMITTED BY APPLICABLE LAW, FPI MAKES NO EXPRESS WARRANTIES OTHER THAN THE WARRANTY SPECIFIED HEREIN. THE DURATION OF ANY IMPLIED WARRANTY IS LIMITED TO DURATION OF THE EXPRESSED WARRANTY SPECIFIED ABOVE. IF IMPLIED WARRANTIES CANNOT BE DISCLAIMED, THEN SUCH WARRANTIES ARE LIMITED IN DURATION TO THE DURATION OF THIS WARRANTY.

Some US states do not allow limitations on how long an implied warranty lasts, or allow exclusion or limitation of incidental or consequential damages, so the above limitations or exclusions may not apply to you.

Customers located outside the US should consult their local, provincial or national legal codes for additional terms, which may be applicable to this warranty.

How to Obtain Warranty Service:

Customers should contact the authorized selling dealer to obtain warranty service. In the event the authorized selling dealer is unable to provide warranty service, please contact FPI by mail at the address listed below. Please include a brief description of the problem and your address, email and telephone contact information. A representative will contact you to make arrangements for an inspection and/or warranty service.

Canadian Warrantor:

FPI Fireplace Products International Ltd.
6988 Venture St.
Delta, British
Columbia Canada,
V4G 1H4

US Warrantor:

Fireplace Products U.S., Inc.
PO Box 2189 PMB 125
Blaine, WA
United States, 98231

Or contact the Regency Customer Care Centre at 1-800-442-7432 (phone) /604-946-4349 (fax) /customerservice@regency-fire.com (e-mail)

Product Registration and Customer Support:

Thank you for choosing a Regency Fireplace. Regency strives to be a world leader in the design, manufacture, and marketing of hearth products. To provide the best support for your product, we request that you complete a product registration form at <http://www.regency-fire.com/Customer-Care/Warranty-Registration.aspx> within **ninety (90)** days of purchase.

Warranty Registration Card



Product Registration and Customer Support:

Thank you for choosing a Regency Fireplace. Regency strives to be a world leader in the design, manufacture, and marketing of hearth products. To provide the best support for your product, we request that you complete a product registration form found on our Web Site under Customer Care within ninety (90) days of purchase.

For purchases made in **CANADA or the UNITED STATES:**

<http://www.regency-fire.com/Customer-Care/Warranty-Registration.aspx>

For purchases made in AUSTRALIA:

<http://www.regency-fire.com.au/Customer-Care/Warranty-Registration.aspx>

You may also complete the warranty registration form below to register your Regency Fireplace Product and mail and/or fax it back to us, and we will register the warranty for you. It is important you provide us with all the information below in order for us to serve you better.

Warranty Registration Form (or Register online immediately at the above Web Site):

Warranty Details	
Serial Number (required):	
Purchase Date (required) (mm/dd/yyyy):	
Product Details	
Product Model (required):	
Dealer Details	
Dealer Name (required):	
Dealer Address:	
Dealer Phone #:	
Installer:	
Date Installed (mm/dd/yyyy):	
Your Contact Details (required)	
Name:	
Address:	
Phone:	
Email:	

For purchases made in CANADA:

FPI Fireplace Products International Ltd.

6988 Venture St.
Delta, British Columbia
Canada, V4G 1H4

Phone: 604-946-5155
Fax: 1-866-393-2806

For purchases made in the UNITED STATES:

Fireplace Products US, Inc.

PO Box 2189 PMB 125
Blaine, WA
United States, 98231

Phone: 604-946-5155
Fax: 1-866-393-2806

For purchases made in AUSTRALIA:

Fireplace Products Australia Pty Ltd

99 Colemans Road
Dandenong South, Vic.
Australia, 3175

Phone: +61 3 9799 7277
Fax: +61 3 9799 7822

For fireplace care and tips and answers to most common questions please visit our Customer Care section on our Web Site. Please feel free to contact your selling dealer if you have any questions about your Regency product.

warranty

PRODUCT LIFE CYCLE:

By recycling your used appliances, you divert waste from your local landfills and help the environment. You also reduce the need for raw materials to manufacture new products. Contact your local municipality for appliance recycling services, local recycling programs, or appliance removal services to ensure your Regency appliance components, and packaging are properly recycled.

Installer: Please complete the following information

Dealer Name & Address: _____

Installer: _____

Phone #: _____

Date Installed: _____

Serial #: _____