

INSTRUCTION MANUAL

Fireplace Inserts & Hearth Heater



SAVE THESE INSTRUCTIONS

Regency Industries Ltd.
780 Vantage Way
Delta, BC
Canada V4G 1A7

Tested by Warnock Hersey
UL907
ULCS628

Thank-you for purchasing a
REGENCY FIREPLACE PRODUCT.

The pride of workmanship that goes into each of our products will give you years of trouble-free enjoyment. Should you have any questions about your product that are not covered in this manual, please contact the **REGENCY DEALER** in your area.

Keep those **REGENCY FIRES** burning.

SAFETY NOTE: If this Insert is not properly installed, a house fire may result. For your safety, follow the installation instructions, contact local building or fire officials about restrictions and installation inspection requirements in your area.

**Medium Flush Insert
(R14)**

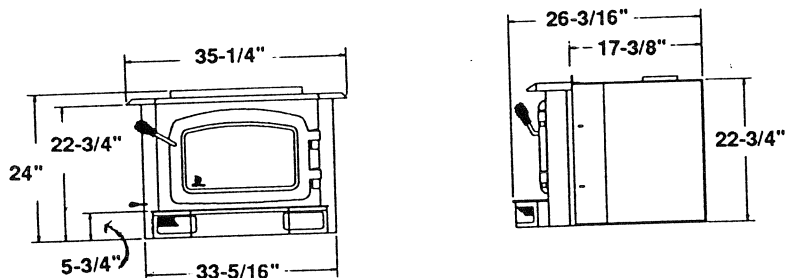

**Large Flush Insert
(R16)**

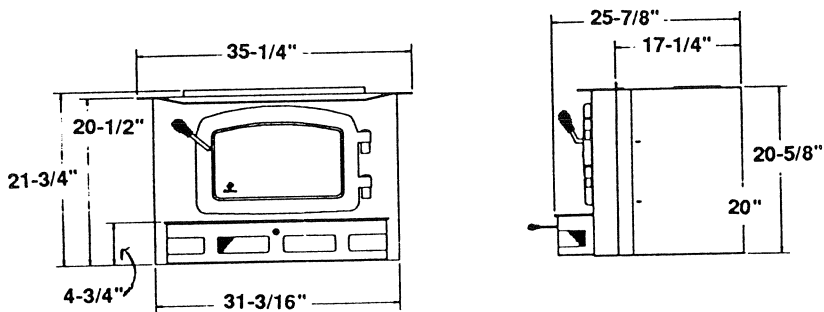

**Hearth Heater
(R12)**

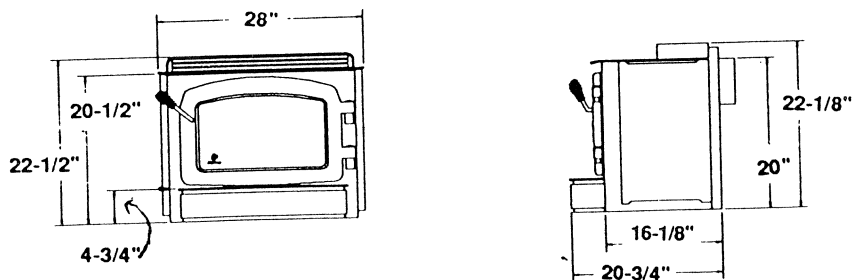

THE REGENCY FIREPLACE INSERT & HEARTH HEATER



	Page
INSTALLATION	
Insert Product Label	4
Hearth Heater Product Label	5
Before Installing Your Unit	6
Chimney Specifications	6
Medium Insert Installed in "0"	
Clearance Factory Built Fireplace	6
Fireplace Specifications	7
Masonry Clearances	7
Factory Build Clearances	7
Installing your Insert	8
A) Into a Masonry Fireplace	8
B) Into a Factory Built Fireplace	9
C) All Units	10
Fan / Blower	11
Floor Protection	11
Glass Installation	11
Firebrick Assembly	11
Door Handle	11
Flue Baffle	12
 OPERATING INSTRUCTIONS	
Draft Control	13
First Fire	13
Fan / Blower	14
Operation (all units)	14
Ash Disposal	14
Safety Guidelines	15
 MAINTENANCE	
Creosote	16
Removal for Cleaning	16
Ways to Prevent and Keep Unit Free of Creosote	16
Door Latch Adjustment	16
Maintenance of Gold Plated Door	17
Door Gasket	17
Glass Cleaning	17
Glass Replacement	17
Glass Removal	17
 WARRANTY	
Warranty	19

INSTALLATION



This is a copy of the label that accompanies each **Regency Insert**. We have printed a copy of the contents here for your review.

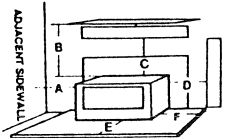

NOTE: Regency units are constantly being improved. Check the label on the unit and if there is a difference, the label on the unit is the correct one.

	<p>LISTED FIREPLACE ACCESSORY INSERT REPORT NOS. 5343 (JULY 87) / 5606 (OCT 88) MODEL: REGENCY INSERT: MEDIUM (R14) LARGE (R16)</p>	<div style="border: 1px solid black; padding: 5px; display: inline-block;">WH-</div>										
<p>LISTED FOR CANADA AND U.S.A. TESTED TO ULC S628. RELEVANT PORTIONS OF UL 1482. UL 907 PROPOSED. INSTALL AND USE ONLY IN ACCORDANCE WITH THE MANUFACTURER'S INSTALLATION AND OPERATING INSTRUCTIONS. INSTALL AND USE ONLY IN A MASONRY FIREPLACE. DO NOT REMOVE BRICKS OR MORTAR FROM A MASONRY FIREPLACE.</p>												
<p>MINIMUM CLEARANCES TO COMBUSTIBLES:</p> <table border="1" style="width: 100%; border-collapse: collapse;"> <thead> <tr> <th style="width: 30%;"></th> <th style="text-align: center;">MEASURED TO UNIT BODY</th> </tr> </thead> <tbody> <tr> <td>A. ADJACENT SIDEWALL</td> <td style="text-align: center;">535MM (21IN)</td> </tr> <tr> <td>B. MANTLE</td> <td style="text-align: center;">405MM (16IN)</td> </tr> <tr> <td>C. TOP FACING</td> <td style="text-align: center;">405MM (16IN)</td> </tr> <tr> <td>D. SIDE FACING</td> <td style="text-align: center;">R14 150MM (6IN) R16 200MM (8IN)</td> </tr> </tbody> </table>				MEASURED TO UNIT BODY	A. ADJACENT SIDEWALL	535MM (21IN)	B. MANTLE	405MM (16IN)	C. TOP FACING	405MM (16IN)	D. SIDE FACING	R14 150MM (6IN) R16 200MM (8IN)
	MEASURED TO UNIT BODY											
A. ADJACENT SIDEWALL	535MM (21IN)											
B. MANTLE	405MM (16IN)											
C. TOP FACING	405MM (16IN)											
D. SIDE FACING	R14 150MM (6IN) R16 200MM (8IN)											
												
<p>COMBUSTIBLE FLOOR BEYOND HEARTH EXTENSION MUST BE AT LEAST 50 MM / 2 IN. BELOW HEARTH EXTENSION LEVEL, AND BE PROTECTED BY A NON-COMBUSTIBLE MATERIAL EXTENDING (E): 405 MM / 16 IN TO THE FRONT AND (F) 150 MM / 6 IN. TO THE SIDES OF THE UNIT. IF THE HEARTH EXTENSION EXTENDS AT LEAST (E) 495 MM / 19-1/2 IN. TO THE FRONT OF THE INSERT, THEN HEARTH EXTENSION AND SURROUNDING FLOOR MAY BE FLUSH.</p>												
<p>FOR USE WITH SOLID FUEL ONLY. OPTIONAL COMPONENTS - FAN SYSTEM - ELECTRICAL RATING: 115 VOLTS, 60 HZ, 1.0 AMP. INSPECT AND CLEAN CHIMNEY FREQUENTLY. UNDER CERTAIN CONDITIONS OF USE CREOSOTE BUILD-UP MAY OCCUR RAPIDLY. OPERATE ONLY WITH DOOR CLOSED. OPEN FEED DOOR TO FEED FIRE ONLY. DO NOT USE GRATE OR ELEVATE FIRE - BUILD WOODFIRE DIRECTLY ON HEARTH. REPLACE GLASS ONLY WITH CERAMIC GLASS.</p>												
<p>MANUFACTURED BY:</p>		<p>REGENCY INDUSTRIES LTD. 7830 VANTAGE WAY DELTA, BC V4G 1A7 MADE IN CANADA</p>										

The Regency Insert Product Label

This is a copy of the label that accompanies each **Regency Hearth Heater**. We have printed a copy of the contents here for your review.

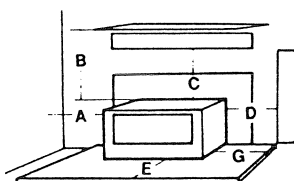
NOTE: Regency units are constantly being improved. Check the label on the unit and if there is a difference, the label on the unit is the correct one.

	<p>LISTED FACTORY BUILT FIREPLACE ACCESSORY HEARTH STOVE CERTIFIED FOR USE IN CANADA AND U.S.A. MODEL: R12 TESTED TO: ULC S628 REPORT NO. 6255 (JULY 1991)</p>	<div style="border: 1px solid black; padding: 5px; display: inline-block;"> WH- </div>																														
<p>INSTALL AND USE ONLY IN ACCORDANCE WITH THE MANUFACTURER'S INSTALLATION AND OPERATING INSTRUCTIONS. INSTALL AND USE ONLY IN MASONRY FIREPLACE OR FACTORY BUILT FIREPLACE. CONTACT LOCAL BUILDING OR FIRE OFFICIALS ABOUT RESTRICTIONS AND INSTALLATION INSPECTION IN YOUR AREA.</p>																																
<p>MINIMUM CLEARANCES TO COMBUSTIBLE MATERIALS (MEASURED FROM INSERT BODY)</p>																																
<p>ADJACENT SIDEWALL MANTLE TOP FACING SIDE FACING HEARTH EXTENSION (DEPTH) HEARTH EXTENSION (ELEVATION) HEARTH EXTENSION (WIDTH)</p>	<p>A) 10in/255mm B) 25in/635mm C) 14in/355mm D) 8.5in/190mm E) 18in/455mm F) 1.5in/38mm G) 6in/150mm</p>																															
<p>INSTALL ONLY ON A NON-COMBUSTIBLE HEARTH RAISED 1.5IN/38MM ABOVE AN ADJACENT COMBUSTIBLE FLOOR. COMBUSTIBLE FLOOR MUST BE PROTECTED BY NON-COMBUSTIBLE MATERIAL.</p> <p>COMPONENTS REQUIRED FOR INSTALLATION MUST HAVE A 6IN/150MM STAINLESS STEEL LINER.</p> <p>DO NOT REMOVE BRICKS OR MORTAR IN MASONRY FIREPLACE. FOR USE WITH SOLID WOOD FUEL ONLY. DO NOT USE GRATE OR ELEVATE FIRE. BUILD WOOD FIRE DIRECTLY ON HEARTH. OPERATE WITH FEED DOOR CLOSED, OPEN TO FEED FIRE ONLY.</p> <p>REPLACE GLASS ONLY WITH CERAMIC GLASS.</p> <p>INSPECT AND CLEAN CHIMNEY FREQUENTLY. UNDER CERTAIN CONDITIONS OF USE CREOSOTE BUILDUP MAY OCCUR RAPIDLY. DO NOT OVERFIRE, IF INSERT GLOWS YOU ARE OVER-FIRING.</p>																																
<div style="border: 1px solid black; border-radius: 15px; width: 100px; height: 80px; margin: 0 auto;"></div>	<h2 style="margin: 0;"><u>CAUTION</u></h2> <p>HOT WHILE IN OPERATION DO NOT TOUCH. KEEP CHILDREN, CLOTHING AND FURNITURE AWAY. CONTACT MAY CAUSE SKIN BURNS. READ ABOVE INSTRUCTIONS.</p>	 <p>MANUFACTURED BY: REGENCY INDUSTRIES LTD. 7830 VANTAGE WAY DELTA, BC V4TG 1A7</p>																														
<p>UNITED STATE ENVIRONMENTAL PROTECTION AGENCY CERTIFIED TO COMPLY WITH JULY 1990 PARTICULATE EMISSION STANDARDS</p>		<div style="border: 1px solid black; padding: 2px; display: inline-block;"> MADE IN CANADA </div>																														
<p>DATE OF MANUFACTURE:</p> <table style="width: 100%; text-align: center; border-collapse: collapse;"> <tr> <td>1991</td> <td>1992</td> <td>1993</td> <td>JAN</td> <td>FEB</td> <td>MAR</td> <td>APR</td> <td>MAY</td> <td>JUN</td> <td>JUL</td> <td>AUG</td> <td>SEP</td> <td>OCT</td> <td>NOV</td> <td>DEC</td> </tr> <tr> <td style="background-color: black; width: 20px; height: 15px;"></td> <td style="background-color: black; width: 20px; height: 15px;"></td> <td style="background-color: black; width: 20px; height: 15px;"></td> <td style="background-color: black; width: 20px; height: 15px;"></td> <td style="background-color: black; width: 20px; height: 15px;"></td> <td style="background-color: black; width: 20px; height: 15px;"></td> <td style="background-color: black; width: 20px; height: 15px;"></td> <td style="background-color: black; width: 20px; height: 15px;"></td> <td style="background-color: black; width: 20px; height: 15px;"></td> <td style="background-color: black; width: 20px; height: 15px;"></td> <td style="background-color: black; width: 20px; height: 15px;"></td> <td style="background-color: black; width: 20px; height: 15px;"></td> <td style="background-color: black; width: 20px; height: 15px;"></td> <td style="background-color: black; width: 20px; height: 15px;"></td> <td style="background-color: black; width: 20px; height: 15px;"></td> </tr> </table>			1991	1992	1993	JAN	FEB	MAR	APR	MAY	JUN	JUL	AUG	SEP	OCT	NOV	DEC															
1991	1992	1993	JAN	FEB	MAR	APR	MAY	JUN	JUL	AUG	SEP	OCT	NOV	DEC																		

The Regency Hearth Heater Product Label

Regency Inserts are constructed with the highest quality materials and assembled under strict quality control procedures that insure years of trouble free and reliable performance.

It is important that you read this manual throughout and fully understand the safe installation and operating procedures. The more you understand the way your Regency Insert operates, the more enjoyment you will experience from knowing that your unit is operating at peak performance.

Before Installing Your Insert

- 1) Read all instructions before installing and using your fireplace insert. Install and use only in accordance with manufacturer's installation and operating instructions.
- 2) Check your local building codes - Building Inspection Department. You may require a permit before installing your insert. Be aware that local codes and regulations may override some items in the manual.

WARNING: Careless installation is the major cause of safety hazard. Check all local building and safety codes before installation of unit.

- 3) Notify your home insurance company that you plan to install a fireplace insert or hearth heater.
- 4) Your fireplace insert is heavy and requires two or more people to move it safely. The insert can be badly damaged by mishandling.
- 5) If your existing fireplace damper control will become inaccessible once you have installed your Regency Insert, you should either remove or secure it in the open position.
- 6) Inspect your fireplace and chimney prior to installing your insert to determine that it is free from cracks, loose mortar or other signs of damage. If repairs are required, they should be completed before installing your insert. Do not remove bricks or mortar from your masonry fireplace.
- 7) Do not connect the insert to a chimney system servicing another appliance or an air distribution duct.

Chimney Specifications

Before installing, check and clean your chimney system thoroughly. If in doubt about its condition, seek professional advice. Your Regency Insert is designed for installation into a masonry fireplace that is constructed in accordance with the requirements of "The Standard for Chimneys, Fireplaces, Vents, and Solid Fuel Burning Appliance", N.F.P.A. 211, or the applicable local code requirements.

Medium Insert and Hearth Heater Installed in "0" Clearance Factory Built Fireplace

The Regency Hearth Heater, as a hearth mounted unit, has been tested and approved to be vented into any "0" clearance Factory Built Fireplace.

The Regency Medium Insert (R14) may be installed into one of the pre-fabricated "0" clearance Factory Built Fireplaces listed below:

Majestic - M-36, L-36, L-42, MD 36, MD 42, MD 36-AO & MD 42-AO, MBUC 36

Heatilator - FP 36, 3036, 3042, 3048, & 3138, 3138EP, Mark 123 Series

Preway - DW36, DW42, B136, B142, B136B, B142B, B136EM, B142EM, B136CEM, B142CEM, B136SEM & B142SEM

IMPORTANT: If the Medium unit is being installed into one of the factory built fireplaces listed above, check that factory variations of the "0" clearance fireplace will allow the insert to physically fit its firebox.

NOTE: The Hearth Heater can be installed into any Factory Built Fireplace.

Fireplace Specifications

Your fireplace opening requires the following minimum sizes:

	Height	Width	Depth
Medium (R14)	21.5"	25"	17"
Large (R16)	23.25"	28.5"	17"
Heath Heater(R12)	20.0"	-	--

Two faceplates are available to seal the fireplace opening:

	Standard	Oversize
Medium (R14)	40"W x 30"H	48"W x 33"H
Large (R16)	44"W x 32"H	50"W x 34"H
Heath Heater(R12)	40 1/4"W x 28"H	48"W x 33"H

Masonry Clearances

The minimum required clearances to combustible materials when installed into a masonry fireplace are:

	Adjacent Sidewall (to Side) A	Mantle (to Top) B	Top Facing (to Top) C	Side Facing (to Side) D	Minimum Hearth Extension* E	Minimum Hearth Elevation* F	Minimum Hearth Side Extension G
Medium Flush	21"/530mm	16"/406mm	16"/406mm	6"/152mm	16"/406mm	2"/50mm	N/A
Large Flush	21"/530mm	16"/406mm	16"/406mm	8"/203mm	16"/406mm	2"/50mm	N/A
Hearth Heater	10"/255mm	25"/635 mm	14"/355mm	8.6"/190mm	18"/455mm	1.5"/38mm	6"/152mm

*Note: If the hearth extension is flush with the floor (item F) it must extend 19.5" in front of the body face (item E).

Factory Built Clearances

(Note: applicable to Medium Insert Only) The minimum required clearances to combustible materials when installed into a factory built "0" clearance fireplace are:

	Adjacent Sidewall (to Side) A	Mantle (to Top) B	Top Facing (to Top) C	Side Facing (to Side) D	Hearth Extension Depth* E	Hearth Extension Elevation* F	Hearth Extension Width G
Medium Flush	21"/530mm	19"/483mm	16"/406mm	6"/152mm	16"/406mm	N/A	N/A
Hearth Heater	10"/255mm	25"/635 mm	14"/355mm	8.6"/190mm	18"/455mm	1.5"/38mm	6"/152mm

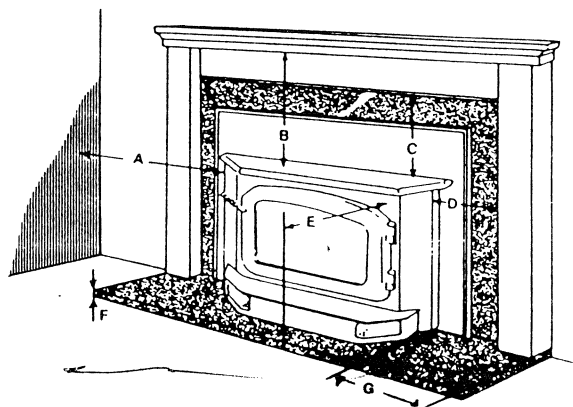

Clearance diagram for Installations

INSTALLATION

Installing Your Insert

Your insert is very heavy and will require two or three people to move it into position. The insert can be made a little lighter by removing the cast iron door by opening it and lifting it off its hinges. Be sure to protect your hearth extension with a heavy blanket or carpet scrap during the installation.

A) Into a Masonry Fireplace

The insert must be installed as per the requirements of your local inspection authority. Three methods of flue connection are acceptable in most areas, these include:

- 1) Positive flue connection, where a large blocking plate and a short connector pipe is used.
- 2) Direct flue connection, where a smaller blocking plate and a connector pipe to the first flue liner tile is used.
- 3) Full flue liner, where a stainless steel rigid or flexible liner pipe is routed from the insert outlet collar to the top of the chimney.

Regency highly recommends the use of a full liner as the safest installation and provides the most optimum performance. Your retailer should be able to help you decide which system would be the best for your application.

Note: A clean-out door is sometimes required, by your inspector, to be installed when either the Positive flue connection or Direct flue connection method is used.

The use of one of the connection methods listed on this page not only increases the safety of your insert by directing the hot gases up the flue, but will also help increase the units efficiency and decrease creosote deposits in the chimney.

When a connected flue or liner is in use, the insert is able to "breathe" better by allowing a greater draft to be created. The greater draft can decrease problems such as, difficult startups, smoking out the door, and dirty glass.

* flue adapter
846-504 will
work

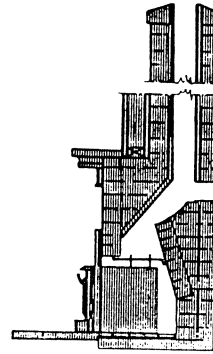

1) Positive Flue Connection with Cleanout

2) Direct Flue Connection with Cleanout

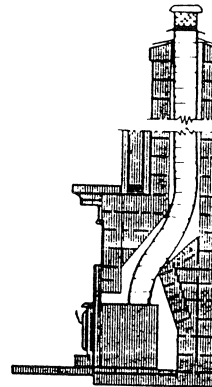
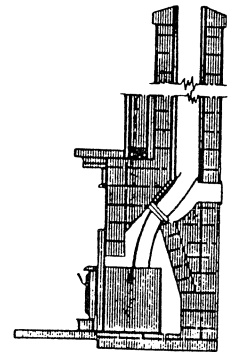

3a) Full Flue Liner (No Cleanout Required)

3b) Hearth Heater with Full Flue Liner (No Cleanout Required)

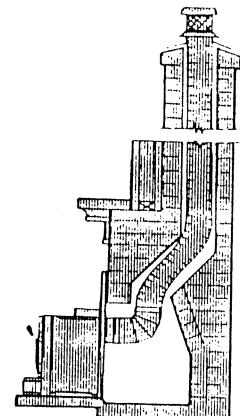

B) Into a Factory Built Fireplace (Medium Insert and Hearth Heater)

- 1) When installed in a factory built fireplace, a full stainless steel rigid or flexible flue liner is mandatory, for both safety and performance purposes. When a flue or liner is in use, the insert is able to breathe better by allowing a greater draft to be created. The greater draft can decrease problems such as, difficult startups, smoking out the door, and dirty glass.

In order to position the flue liner, the existing rain cap must be removed from your chimney system. In most cases the flue damper should also be removed to allow passage of the liner.

- 2) In most cases opening the existing spark screens fully should give enough room for the insert installation. If it does not, remove and store.
- 3) If the floor of your fireplace is below the level of the fireplace opening, adjust the insert's levelling bolts to accommodate difference. When additional shimming is required, use non-combustible masonry or steel shims.
- 4) Measure approximately the alignment of the flue liner with the position of the smoke outlet hole on the insert to check for possible offset. If an offset is required, use a proper stainless steel unit available with the chimney liner.
- 5) Once the above items have been checked, slide your insert into position after first positioning the flue liner and offset if required. (Re-install raincap at completion of installation).

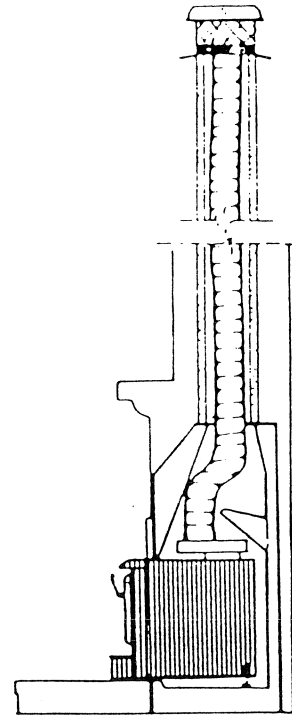

Medium Insert

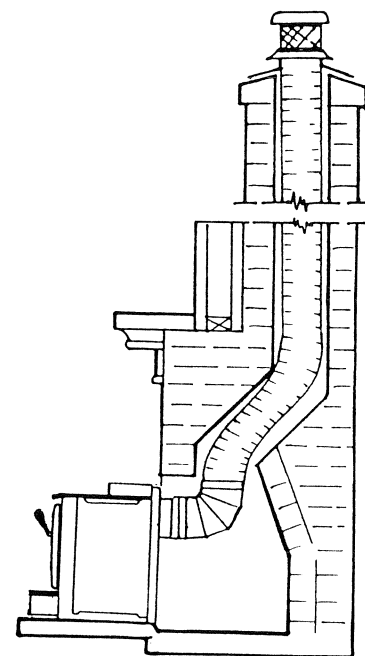

Hearth Heater

INSTALLATION

C) All Units

Prior to sliding your insert into its final position and attaching the connector or liner pipe, the faceplate side panel plates must be installed as follows:

- 1) Slide the spring nuts (supplied) over the slots in the insert's side convection panels (the spring nuts may need to be squeezed with a pair of pliers first, to help them stay in position).
- 2) Screw the side faceplate panels, (item A in the diagram) one to each side.
- 3) Using the top panel (item B in the diagram) as a gauge, check that the side panels are within approximately 1/4" of the overall width. If the difference is greater than this, use the supplied washers to attain the required width.

The unit may now be slid into final position and attached to the connection system.

Once connection is made, the insulation strips should be installed between the insert faceplates and the fireplace face. The faceplate top may now be installed (with insulation strip behind) by aligning its brackets with the top flange on the side shields and the angle iron bar on the insert top. The faceplate trim may be installed to the edge of the faceplate at this time.

Note: It may be easier to install the insulation, faceplate top and faceplate trim with the unit pulled slightly away from the fireplace face. If this is done, be very careful not to disturb the connector when shifting the unit to its final position.

Now that your insert is installed, check once more that all the clearances from the unit to any combustible materials are correct as listed earlier.

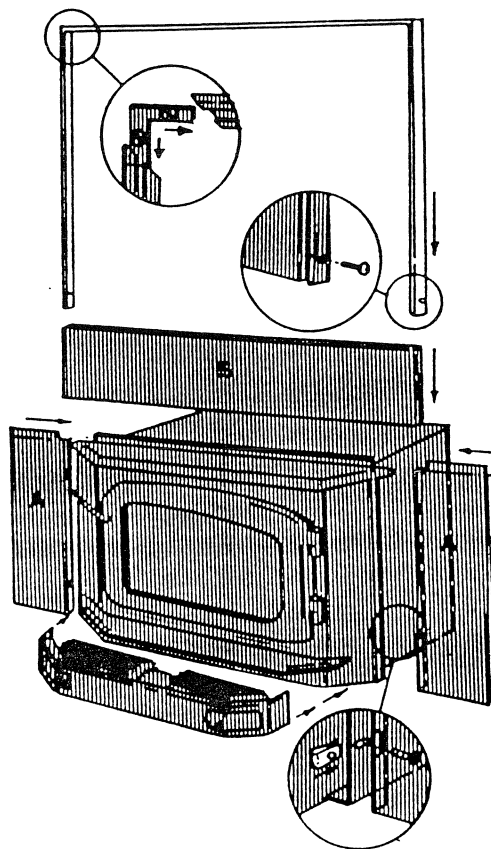

Medium and Large Insert

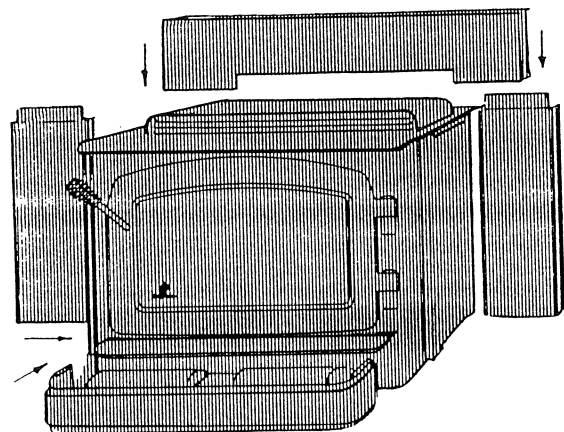

Hearth Heater

Fan/Blower

Medium (R14) and Hearth Heater (R12)

To attach your fan, align the fan supports with the offset clips attached to the under side of your ash lip and slide into place. The tension holding your fan in place may be adjusted by either increasing or decreasing the offset spacing on the ash lip clips.

Do not turn fan ON until your insert has reached operating temperature or at least 30 minutes after starting fire.

Large (R16)

Your fan should only be installed once the unit is in place in order to prevent any damage to the fan. To attach, follow the instructions provided with the fan. Make sure to install the rubber grommet to the fan housing before it is installed on the insert.

Do not turn fan ON until your insert has reached operating temperature or at least 30 minutes after starting fire.

Floor Protection

Please check to ensure that your floor protection and hearth will meet the standards for clearance to combustibles. Your hearth extension must be made non-combustible material.

Glass Installation

Install glass by using screws in retainer at rear of door. Do not overtighten screws. See diagram under maintenance.

Firebrick Assembly

Firebrick is included to extend the life of your insert and radiate heat more evenly. Check to see that all firebricks are in their correct positions and have not become misaligned during shipping.

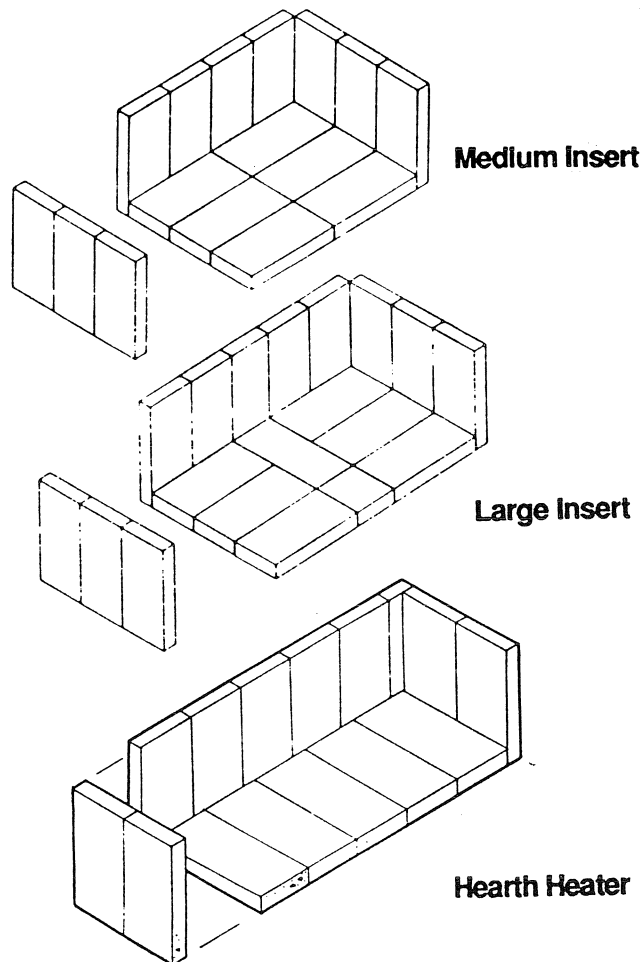

Door Handle

Attach spring handle by rotating counter clockwise onto rod. Ensure that the rod fits into the entire length of the spring handle. See Diagram below.

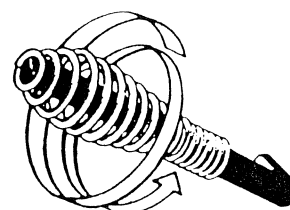

Flue Baffle

The flue baffle system located in the upper area of the firebox is removable to make it easier to clean your chimney system, or to replace it if extensive warpage takes place. Minor baffle warpage is acceptable and should be ignored. Overfiring your insert may cause the baffle to warp excessively, which may then require it to be replaced. Excessive warpage means the baffle will not stay in place or obstruct the smoke from leaving the firebox.

Please note that the baffle may become dislodged if too much fuel is forced into the firebox. The baffle can also shift during transit so ensure that it is correctly installed prior to lighting your first fire. The Me-

dium Insert has a single flue baffle, while the Large Insert has a dual baffle system.

The insert uses an insulating batt above the baffle. Make sure that this batt is laying flat and does not obstruct the smoke from getting up the flue opening. This insulating batt may be wrapped in paper for handling purposes and does not require removal. Batt hold down weights are supplied with the unit and are to be placed on the insulation to either side of the flame spreader as shown in the diagram. In the Hearth Heater also place a hold down weight at the rear, directly in front of the flue opening.

Medium Insert and Hearth Heater

1) Lift the front end of the baffle up and over the rear of the air tube. On Hearth Heater (R12) remove center tube by sliding it sideways first and then down

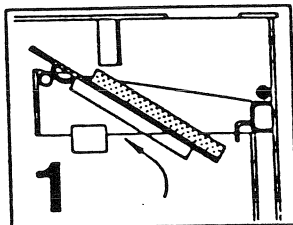

2) Lift the rear of the baffle, pivoting it on the air tube, until it clears the rear air channel.

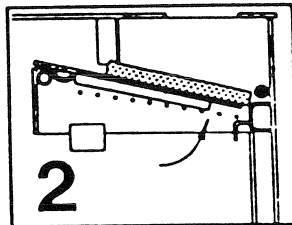

3) Slide the rear of the baffle onto the top of the rear air channel in front of the locating tabs. Make sure that the insulation is lying flat and does not obstruct the smoke from getting up the flue opening. Place hold down weights on top of the insulation - one on each side.

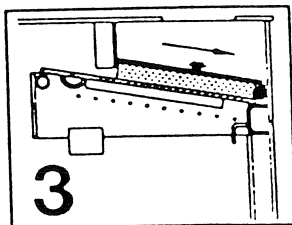

Large Insert

1) Place insulation above tubes and rear channel.

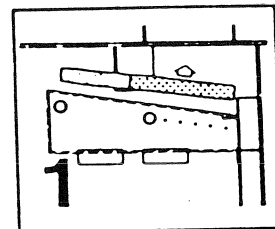

2) Install rear baffle as shown.

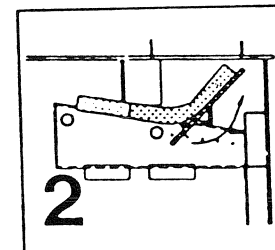

3) Install front baffle as shown.

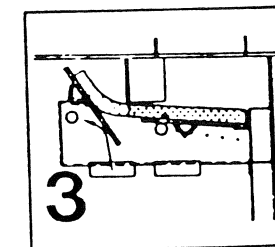

4) Ensure proper baffle and insulation position. Make sure the insulation is laying flat and does not obstruct the smoke from getting up the flue opening. Place hold-down weights on top of the insulation - one on each side.

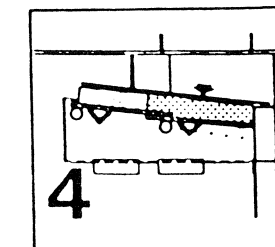

With your unit now correctly installed and safety inspected by your local authority, you are now ready to start a fire. Before establishing your first fire, it is important that you fully understand the operation of your draft control.

Draft Control

The draft rod at the side of the Medium Insert (R14) and the Hearth Heater, and at the front of the Large Insert (R16) controls the intensity of the fire by increasing or decreasing the amount of air allowed into the firebox. To increase your draft - pull open, and to decrease - push closed.

As well as a primary and glass wash air system, the unit has a full secondary draft system that allows air to the induction ports at the top of the firebox, just below the flue baffle.

WARNING: To build a fire in ignorance or to disregard the information contained in this section can cause serious permanent damage to the unit and void your warranty.

First Fire

When your installation is completed and inspected, you are ready for your first fire.

- 1) Open control fully.
- 2) Open firebox door and build a small fire using paper and dry kindling. Secure door on the firebox and wait a few minutes for a good updraft in the flue to establish the fire. (Leaving the door slightly open will help your fire start more rapidly.)

CAUTION: Never leave unit unattended if door is left open. This procedure is for fire start-up only, as unit may over-heat if door is left open for too long.

- 3) With the draft still in the fully open position, add two or three seasoned logs to your fire. Form a trench in the ash bed to allow air to reach the rear of the firebox prior to closing the door.
- 4) After about 15 to 20 minutes, when your wood has begun to burn strongly, adjust your draft control down to keep the fire at a moderate level.

WARNING: Never build a roaring fire in a cold stove. Always warm your stove up slowly!

- 5) Once a bed of coals has been established, you may adjust the draft control to a low setting to operate the unit in its most efficient mode.
- 6) During the first few fires, keep the combustion rate at a moderate level and avoid a large fire. Only after 5 or 6 such fires can you operate the insert at its maximum setting, and only after the metal has been warmed.
- 7) For the first few days, the insert will give off an odor from the paint. This is to be expected as the high temperature paint becomes seasoned. Windows and/or doors should be left open to provide adequate ventilation while this temporary condition exists. Burning the insert at a very high temperature the first few times may damage the paint. Burn fires at a moderate level the first few days.

- 8) Do not place anything on the insert top during the curing process. This may result in damage to your paint finish.
- 9) During the first few days it may be more difficult to start the fire. As you dry out your fire brick and your masonry flue (if applicable), your draft will increase.
- 10) For those units installed at higher elevations or into sub-standard masonry fireplaces, drafting problems may occur. Consult an experienced dealer or mason on methods of increasing your draft.
- 11) Some cracking and popping noises may be experienced during the heating up process. These noises will be minimal when your unit reaches temperature.
- 12) Before opening your door to reload, open draft fully for approximately 10 to 15 seconds until fire has been re-established. This will minimize any smoking.
- 13) All fuel burning appliances consume oxygen during operation. It is important that you supply a source of fresh air to your unit while burning. A slightly opened window is sufficient for this purpose.

CAUTION: If the body of your unit or flue baffle starts to glow, you are overfiring. Stop loading fuel immediately and close the draft control until the glow has completely subsided.
- 14) Green or wet wood is not recommended for your unit. If you must add wet or green fuel, open the draft control fully until all moisture has been dispersed by the intense fire. Once all moisture has been removed, the draft control may be adjusted to maintain the fire.
- 15) If you have been burning your insert on a low draft, use caution when opening the door. After opening the damper, open the door a crack, and allow the fire to adjust before fully opening the door.
- 16) The controls of your unit should not be altered to increase firing for any reason.

Fan Operation (all units)

The fan is to be operated only with the draft control rod **pulled out at least 1/2" from the fully closed position**. The fan is not to be operated when the draft control rod is in the closed position (pushed in). The fully closed position is the low burn setting.

The fan unit must not be turned on until a fire has been burning for at least 30 minutes. As well, after each fuel loading the fan must be shut off until 30 minutes has elapsed.

To operate fan automatically, push switch on side of fan housing to "Auto" and second switch to either "High" or "Low" for fan speed. This will allow the fan to shut off once the fire has gone out and the unit has cooled to below a useful heat output range.

To manually operate the fan system, push the first switch to "Man" and second switch to either "high" or "Low". This will bypass the sensing device and allow full control of the fan. Switching from "Auto" to "Manual" or "High" to "Low" may be done at anytime.

Ash Disposal

During constant use, ashes should be removed every few days. Please take care to prevent the build-up of ash around the start-up air housing located inside the firebox, under the loading doorlip.

DO NOT ALLOW ASHES TO BUILD UP TO THE LOADING DOORS.

Only remove ashes when the fire has died down. Even then, expect to find a few hot embers. Always leave 1 to 2 inches of ash in the bottom of the firebox. This helps in easier starting and a more uniform burn of your fire.

Ashes should be placed in a metal container with a tight fitting lid. The closed container of ashes should be placed on a noncombustible floor or on the ground, well away from all combustible materials, pending final disposal. If the ashes are disposed of by burial in soil or otherwise locally dispersed, they should be retained in the closed container until all cinders have thoroughly cooled. Other waste should not be placed in the ash container.

Some Safety Guidelines

- 1) Never use gasoline, gasoline type lantern fuels, kerosene, charcoal lighter fuel, or similar liquids to start or 'freshen up' a fire in your heater. Keep all such liquids well away from the heater while it is in use.
- 2) Keep the door closed during operation and maintain all seals in good condition.
- 3) Do not burn large quantities of paper in your insert.
- 4) If you have smoke detectors, prevent smoke spillage as this may set off a false alarm.
- 5) Do not overfire your insert. If the insert or its flue baffle begin to glow, you are overfiring. Stop adding fuel and close the draft control. Overfiring can cause extensive damage to your stove including warpage and premature steel corrosion. Overfiring will void your warranty.
- 6) Do not permit creosote or soot buildup in the chimney system. Check and clean chimney at regular intervals.
- 7) Your Regency Insert can be very hot. You may be seriously burned if you touch the insert while it is operating. Warn children of the burn hazard.
- 8) The insert consumes air while operating, provide adequate ventilation with an air duct or open a window while the insert is in use.
- 9) Do not use grates, irons or other methods for supporting fuel. Burn directly on the bricks.
- 10) Open the draft control fully for 10 to 15 seconds prior to slowly opening the door when refueling the fire.
- 11) Do not connect your unit to any air distribution duct.
- 12) Your insert should burn dry, standard firewood only. The use of "mill ends" is discouraged as this fuel can easily overheat your insert. Evidence of excessive overheating will void your warranty. As well, a large portion of sawmill waste is chemically treated lumber, which is illegal to burn in many areas. Chemically treated fire logs also must not be burned in your insert.
- 13) Do not store any fuel closer than 2 feet from your unit.
- 14) Do not burn salt drift wood as it will corrode your unit and void the warranty.

It is very important to carefully maintain your insert, including burning seasoned wood and maintaining a clean stove and chimney system. Have the chimney cleaned before the burning season and as necessary during the season, as creosote deposits may build up rapidly. Moving parts of your insert require no lubrication.

Creosote

When wood is burned slowly, it produces tar and other organic vapors, which, when combined with moisture, form creosote. The creosote vapors condense in the relatively cool chimney flue of a slow-burning fire. As a result, creosote residue accumulates on the flue lining. When ignited, this creosote can make an extremely hot fire.

Removal for Cleaning etc

Removal of your insert for cleaning purposes is usually not required if a proper installation has been done. In the event that removal is required, be sure not to damage any parts needed for re-installation. In most cases removal and replacement of the flue baffle system should allow full access for cleaning.

WARNING:

Things to remember in case of chimney fire:

- 1) Close draft control
- 2) Call the Fire Department

Ways to Prevent and Keep Unit Free of Creosote

- 1) Burn insert with draft control wide open for about 45 minutes every morning during burning season. This helps to prevent creosote deposits within the heating system.
- 2) Burn insert with draft control wide open for about 10 - 15 minutes every time you apply fresh wood. This allows the wood to achieve the charcoal stage faster and burns up any wood vapors which might otherwise be deposited within the system.
- 3) **Only burn seasoned wood!** Avoid burning wet or green wood. Seasoned wood has been dried at least one year.

- 4) A small hot fire is preferable to a large smoldering one that can deposit creosote within the system.
- 5) Check the chimney at least twice a month during the burning season for creosote build-up.
- 6) Have chimney system and unit cleaned by competent chimney sweeps twice a year during the first year of use and at least once a year thereafter or when needed.

Door Latch Adjustment

The door latch may require adjustment as the door gasket material compresses after a few fires. Removal of the spacer washer, shown in the diagram below, will allow the latch to be moved closer to the door frame, causing a tighter seal. Remove and replace the nuts, washer as shown.

