

F2450CSA Wood Medium Stove

Model	F2450CSA
Cordwood BTU's	75,000 BTU's
Emissions (grams/hr) EPA Certified	2.3 grams/hr 0.10 grams/MJ (output)
Efficiency (HHV)*	73.3%
Flue Size	6" (152mm)
Maximum Log Size	18" (457 mm)
Firebox Size	2.3 cu.ft.

*The stated efficiency is based on the higher heating value of the fuel. This Model cannot be sold in the U.S.A.



UNIT DIMENSIONS

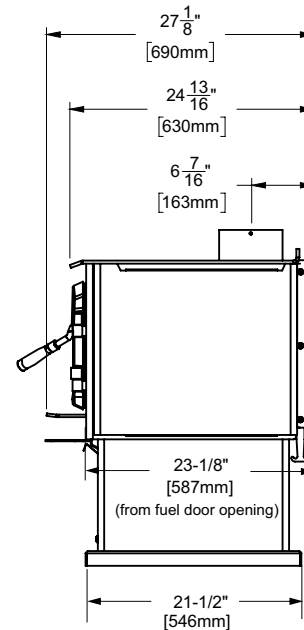
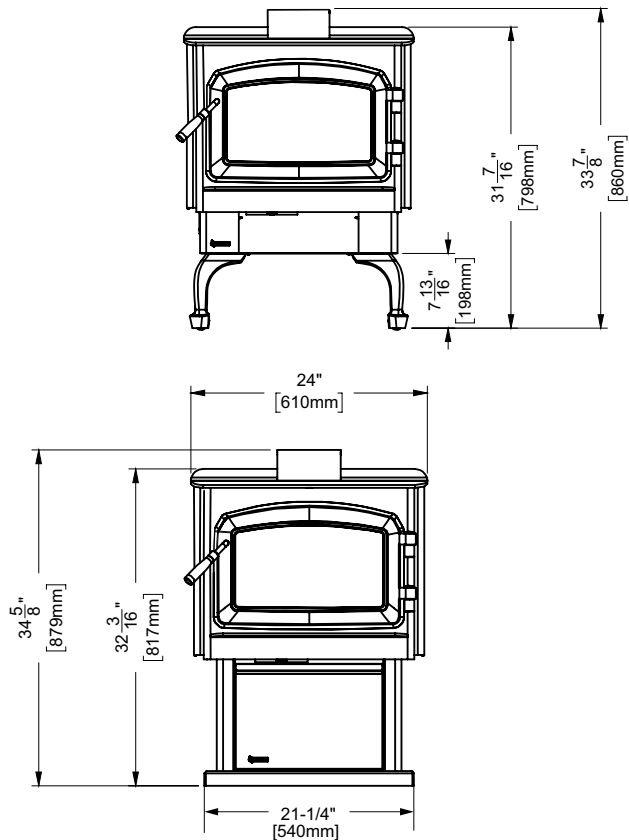

OUTSIDE AIR DIMENSIONS

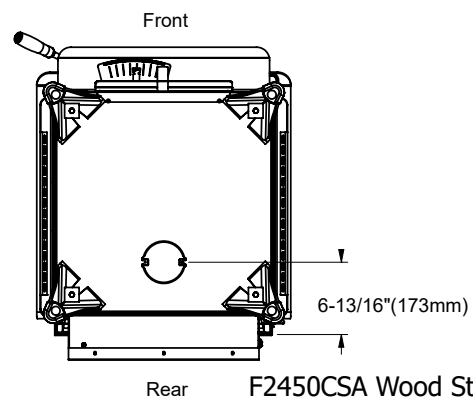
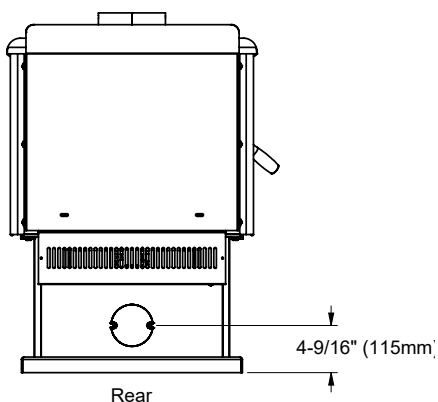

MINIMUM CLEARANCE TO COMBUSTIBLE MATERIALS

Please read the section below carefully as clearances depend on whether the airmate or the rear heat deflector is installed on the stove.

Measurements "From Unit" are from the top plate of the stove to a side wall or to a corner, and from the rear heat shield to a back wall.

Clearances may only be reduced by means approved by the regulatory authority.
Minimum ceiling height - 83" (2108mm) (measured from base of appliance)

NOTE: This clearance is also required for air space between the appliance and wall/ceiling.
Clearances to combustibles are for the safety of the property. To avoid overheating and damaging the appliance these clearances should be maintained for non-combustibles also.

NOTE: Be aware that local Codes and Regulations may override some clearances listed in this manual.
Check with your local inspector.

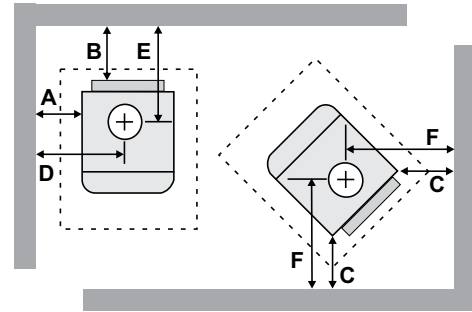

Residential Installation "C" Vent (Single Wall)

Unit	From Unit		From Corner		From Flue Center-Line	
	A	B	C	D	E	F
Medium F2450 with Airmate	16" (406mm)	9-1/2" (241mm)	8" (203mm)	28" (711mm)	16" (406mm)	20" (508mm)
with Rear Deflector	16" (406mm)	11-1/2" (292mm)	8" (203mm)	28" (711mm)	18" (457mm)	20" (508mm)

Residential Close Clearance (To be installed with required pipe components)

When the stove is installed as a close clearance residential unit, a listed double wall connector is required from the stove collar to the ceiling level.

Unit	From Unit		From Corner		From Flue Center-Line	
	A	B	C	D	E	F
Medium F2450 with Airmate	15" (381mm)	8" (203mm)	6" (152mm)	27" (686mm)	14-1/2" (368mm)	18" (457mm)
with Rear Deflector	15" (381mm)	10" (254mm)	6" (152mm)	27" (686mm)	16-1/2" (419mm)	18" (457mm)

Transportable Building Close Clearance (To be installed with required pipe components)

"C" Vent single wall pipe is not approved for Transportable Building installations. (Refer to Transportable Building Instructions.)

Unit	From Unit		From Corner		From Flue Center-Line	
	A	B	C	D	E	F
Medium F2450 with Airmate	15" (381mm)	8" (203mm)	6" (152mm)	27" (686mm)	14-1/2" (368mm)	18" (457mm)
with Rear Deflector	15" (381mm)	10" (254mm)	6" (152mm)	27" (686mm)	16-1/2" (419mm)	18" (457mm)

MINIMUM ALCOVE CLEARANCE AND CLEARANCE TO COMBUSTIBLE MATERIALS

The Regency Freestanding models have been alcove approved and must be installed with a listed double wall connector to the ceiling level.

Note: Minimum alcove ceiling height - 83" (Measured from base of appliance)

Maximum depth of alcove - 48"

NOTE: This clearance is also required for air space between the appliance and wall/ceiling. Where the appliance is installed less than 8" from a rear wall, the ember pad only needs to extend to the base of the wall based on the clearances noted in this manual.

NOTE: The measurements for floor protection for front are taken from the fuel door opening and from the side of the stove for side clearances.

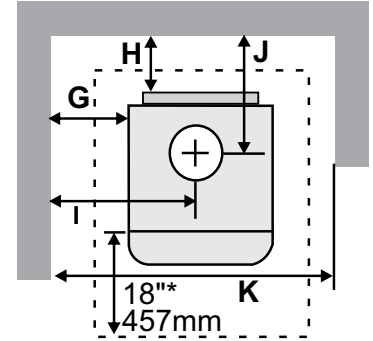

Unit	From Unit		From Flue Centerline		From Wall
	G	H	I	J	K
Medium F2450 with Airmate	15" (381mm)	8" (203mm)	27" (686mm)	14-1/2" (368mm)	54" (1372mm)
with Rear Deflector	15" (381mm)	10" (254mm)	27" (686mm)	16-1/2" (419mm)	54" (1372mm)

FLOOR PROTECTION (EMBER PROTECTION ONLY REQUIRED)

A combustible floor must be protected by a non-combustible material (like tile, concrete board, or certified to UL-1618 Type 1, or as defined by local codes).

*Canada: Beneath the heater and extending to at least 18" on the fuel loading side and at least 8" on the sides and back.

Note: The measurements for floor protection for front are taken from fuel door opening & sides are taken from the unit heat shield. Where the appliance is installed less than 8" (203 mm) from a rear wall, the ember pad only needs to extend to the base of the wall based on the clearances noted in this manual.

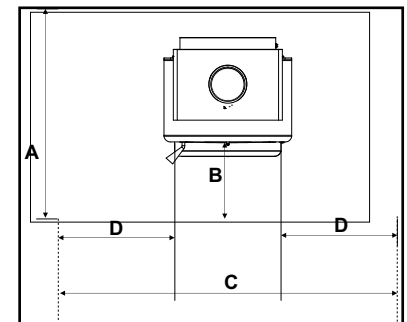

Minimum Overall Depth (Y) of Floor Protector					
Unit		Edge of Fuel Door Opening to Edge of Hearth		Side of the Stove (Both Sides)	
		A	B	C	D
F2450	Canada	49" (1245mm)	18" (457mm)	40-3/8" (1026 mm)	8" (203mm)

Minimum Overall Depth (Y) of Floor Protector					
Reference only when hearth pad is installed to rear wall at minimum pipe clearances.		Hearth Depth	Edge of Fuel door opening to edge of hearth	Hearth Width	Side of the Stove (Both Sides)
Residential Installation "C" Vent (Single Wall)					
Unit		A	B	C	D
F2450 with Airmate	Canada	50-1/2" (1283mm)	18" (457mm)	40-3/8" (1026 mm)	8" (203mm)
F2450 with Rear Deflector	Canada	52-1/2" (1334mm)	18" (457mm)	40-3/8" (1026 mm)	8" (203mm)
Residential Close Clearance (To be installed with required pipe components)					
Unit		A	B	C	D
F2450 with Airmate	Canada	48" (1219mm)	18" (457mm)	40-3/8" (1026 mm)	8" (203mm)
F2450 with Rear Deflector	Canada	50" (1270mm)	18" (457mm)	40-3/8" (1026 mm)	8" (203mm)

FLOOR PROTECTION (CORNER INSTALLATION)

A combustible floor must be protected by non-combustible material (like tile, concrete board, or certified to UL-1618 or as defined by local codes) extending beneath the heater and a minimum of 8" (203mm) from each side and minimum 18" (457 mm) from the front face of the stove and minimum 8" (203 mm) (or the rear clearance to combustibles whichever is smaller) from the rear of the stove.

When installed with horizontal venting, non-combustible floor protection must beneath the flue pipe and extend 2" (51mm) beyond each side.

Minimum Overall Width (X) of Floor Protector for all installations:

Stove F2450 40-3/8" (1026 mm)

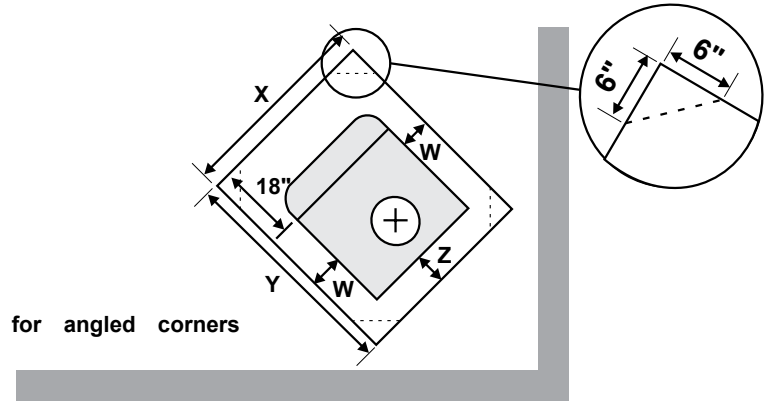

Floor protection must extend 18" (457 mm) to the front and 8" (203 mm) to back & sides of the stove.

Minimum Overall Depth (Y) of Floor Protector			
Unit	Residential "C" Vent		Side of the Stove (Both Sides)
	Y	Z	W
Medium F2450	Canada - 49" (1245 mm)	8" (203 mm)	8" (203 mm)

Minimum Overall Depth (Y) of Floor Protector - Corner Hearth				
Reference only when hearth pad is installed to rear wall at minimum pipe clearances.				
	Hearth Depth			
F2450	L	M	N	O
Residential Installation "C" Vent (Single Wall)				
Canada	40-3/8" (1026 mm)	63-7/16" (1611 mm)	54-7/8" (1394 mm)	26-5/16" (669 mm)
Residential Close Clearance (To be installed with required pipe components)				
Canada	40-3/8" (1026 mm)	60-9/16" (1539 mm)	52-7/8" (1343 mm)	24-5/16" (618 mm)

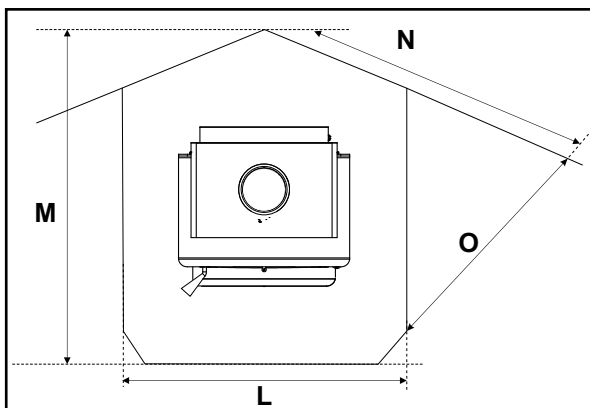

TRANSPORTABLE BUILDINGS CANADA

For installations, see Outside Air Kit - Part # 846-502.

There are further requirements when installing this unit into a transportable building in Canada only.

Once you have properly marked the position of your unit and the floor protection as outlined in the Residential Installation items #1 through #8, a supply of fresh air has to be supplied to your unit.

See Optional Outside Air Kit instructions in this manual.

Place your unit in position and secure it to the floor using two lag bolts 3/8" (10mm) x 3-1/2" (89mm) through the two holes inside the pedestal base. It is important to maintain the structural integrity of the transportable building floor, walls and roof when installing your unit.

For transportable building, the unit must be grounded using a #8 ground wire with approved termination and star washer.

CAUTION: At no time use unlabelled parts, or substitute parts made for another chimney system.

Install as per chimney manufacturer's installation instructions.

1. Identify the position of the outside air damper by the orientation of the metal handle that rests outside the galvanized pipe. The metal handle and the damper disc are in line with each other. This means that if the metal handle is in a horizontal position, the damper is flat and fully open.
2. Open the damper fully whenever you start a fire. This will allow the outside air to be drawn in the pedestal base eliminating any potential smoke escaping the stove and entering the room. (Negative air pressure).

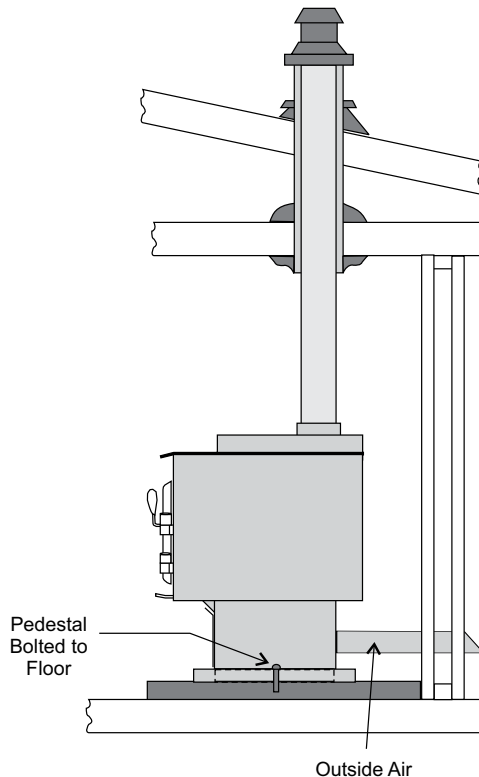

WARNING: Operate only with door fully closed - open feed door to feed fire only.

In addition to standard installation instructions the following requirements are mandatory for installation in a transportable building.

1. **The stove must be permanently bolted to the floor of the transportable building using the floor screws provided.**
2. The stove must have a permanent outside air source for combustion.
3. The stove must be electrically grounded to the steel chassis of the transportable building.
4. A listed double-wall connector chimney system, roof thimble, spark arrestor and roof flashing kit suitable for use in transportable buildings must be used.
5. If the chimney exits the transportable building at a location other than through the roof, and exits at a point 7ft. (2130mm) or less above the ground level on which the transportable building is positioned a guard or method of enclosing the chimney shall be fitted at the point of exit for a height up to 7ft. (2130mm).
6. The chimney shall be attached directly to the room heater and shall extend at least 3 ft. (914mm) above the part of the roof through which it passes. The top of the chimney should project at least 2ft. (610mm) above the highest elevation of any part of the transportable building within 10 ft. (3048mm) of the chimney.
7. The chimney system shall comply with Local Requirements.
8. Any openings in a chimney guard where required must not permit the entrance of 3/4" (19mm) diameter rod.
9. **CAUTION: THE STRUCTURAL INTEGRITY OF THE TRANSPORTABLE BUILDING ROOF, FLOOR, WALLS AND CEILING MUST BE MAINTAINED.**
10. Check any other local building code as other local codes may apply.
11. **WARNING: DO NOT INSTALL IN A SLEEPING ROOM OF A TRANSPORTABLE BUILDING.**
12. Use silicone to create an effective vapour barrier at the location where the chimney or other component penetrates to the exterior of the structure.

This stove may be connected to a lined masonry chimney or a listed factory built chimney suitable for use with solid fuels and conforming to ULC629 in Canada. Do not connect it to a chimney serving another appliance. To do so will affect the safe operation of both appliances, and will void the stove warranty. You must comply with the local authority having jurisdiction and/or in Canada, CSA installation standard B365-M87.

The chimney connector must be 6" diameter, 24 MSG Black/Blue steel. Do not use aluminum or galvanized steel, they cannot properly withstand the extreme temperatures of a wood fire. The chimney connector between the stove and the chimney should be as short and direct as possible.

The chimney connector must be attached to either an approved masonry chimney or one of the listed factory built chimneys suitable for use with solid wood fuel. All joints must be tight and fastened with sheet metal screws.

STEP-BY-STEP CHIMNEY AND CONNECTOR INSTALLATION

Note: These are a generic set of chimney installation instructions. Always follow the manufacturers own instructions explicitly. Check the Minimum Recommended Flue Heights section (Table 1).

1. With your location already established, cut and frame the roof hole. It is recommended that no ceiling support member be cut for chimney and support box installation. If it is necessary to cut them, the members must be made structurally sound.
2. Install radiant shield and support from above.
3. Stack the insulated pipe onto your finish support to a minimum height of 3 feet above the roof penetration, or 2 feet above any point within 10 feet measured horizontally. There must be at least 3 feet of chimney above the roof level.

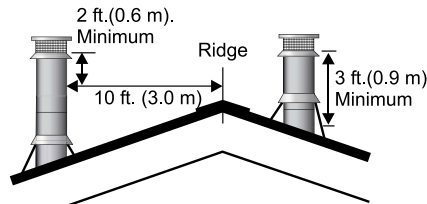

Note: Increasing the chimney height above this minimum level will sometimes help your unit to "breathe" better by allowing a greater draft to be created. This greater draft can decrease problems such as, difficult start-ups, back-smoking when door is open, and dirty glass. It might be sufficient to initially try with the minimum required height, and then if problems do arise add additional height at a later date.

4. Slide the roof flashing over your chimney and seal the flashing to the roof with roofing compound. Secure the flashing to your roof with nails or screws.
5. Place the storm collar over the flashing, sealing the joints with a silicone caulking.
6. Fasten the raincap with spark screens (if required) to the top of your chimney.
7. To complete your chimney installation, install the double wall connector pipe from the stove's flue collar to the chimney support device.

8. If you are using a horizontal connector, the chimney connector should be as high as possible while still maintaining the 18" (457mm) minimum distance from the horizontal connector to the ceiling.

NOTE: Residential Close Clearance and Alcove installations require a listed double wall connector from the stove collar to the ceiling level.

The diagrams below illustrate one way to install your unit into a standard ceiling or with a horizontal connector. Check with your dealer or installer for information on other options available to you.

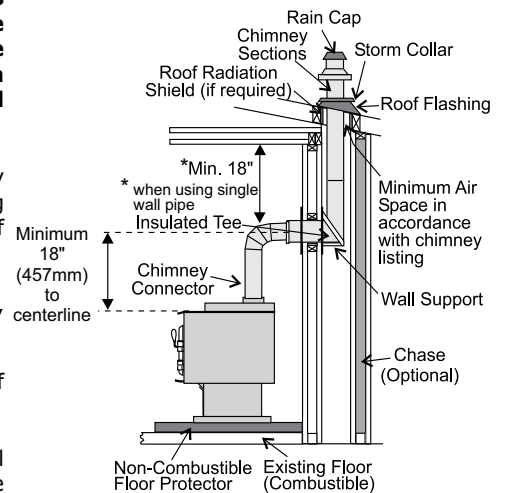
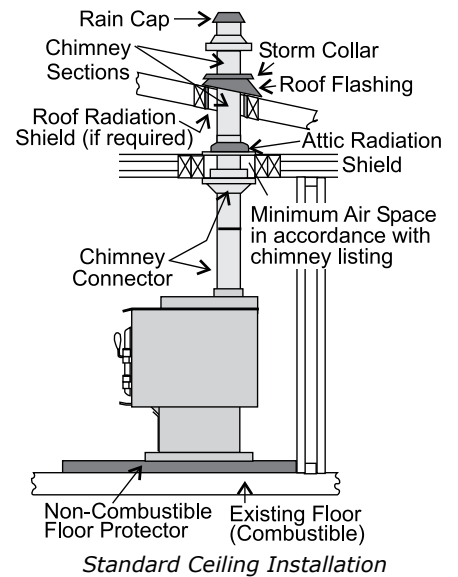

⚠ WARNING

THE CHIMNEY CONNECTOR IS TO BE USED ONLY WITHIN THE ROOM, BETWEEN THE STOVE AND CEILING/ WALL. NEVER USE A CHIMNEY CONNECTOR TO PASS THROUGH AN ATTIC OR ROOF SPACE, CLOSET OR SIMILAR CONCEALED SPACE, OR A FLOOR, OR CEILING. AN EFFECTIVE VAPOR BARRIER MUST BE MAINTAINED AT THE LOCATION WHERE THE CHIMNEY OR COMPONENT PENETRATES TO THE EXTERIOR OF THE STRUCTURE. ALWAYS MAINTAIN THE MINIMUM CLEARANCES TO COMBUSTIBLES AS REQUIRED BY THE APPLICABLE BUILDING CODES.

MASONRY CHIMNEY

Ensure that a masonry chimney meets the minimum standards of the National Fire Protection Association (NFPA) by having it inspected by a professional. Make sure there are no cracks, loose mortar or other signs of deterioration and blockage. Have the chimney cleaned before the stove is installed and operated. When connecting the stove through a combustible wall to a masonry chimney, special methods are needed.

Ensure that an effective vapour barrier at the location where the chimney or other component penetrates to the exterior of the structure.

When referencing installation or connection to masonry fireplaces or chimneys, the masonry construction must or shall be code complying.

This unit is designed to use either a 5.5" (140mm) or 6" (152mm) flue liner only in the confines of the masonry chimney.

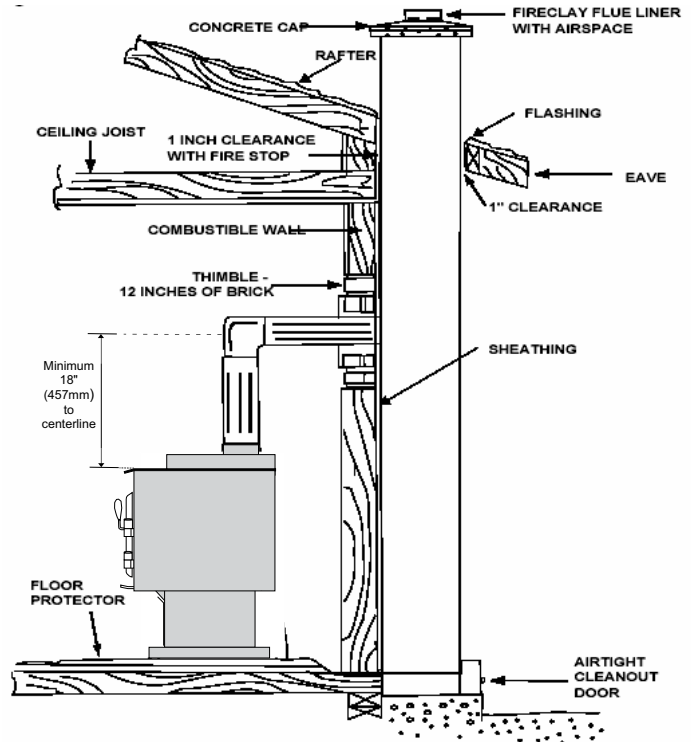

MASONRY FIREPLACE

There are listed kits available to connect a stove to a masonry fireplace. The kit is an adapter that is installed at the location of the fireplace damper. The existing damper may have to be removed to allow installation.

Ensure that an effective vapour barrier at the location where the chimney or other component penetrates to the exterior of the structure.

This unit is designed to use either a 5.5" (140mm) or 6" (152mm) flue liner only in the confines of the masonry chimney as shown.

When referencing installation or connection to masonry fireplaces or chimneys, the masonry construction must or shall be code complying.

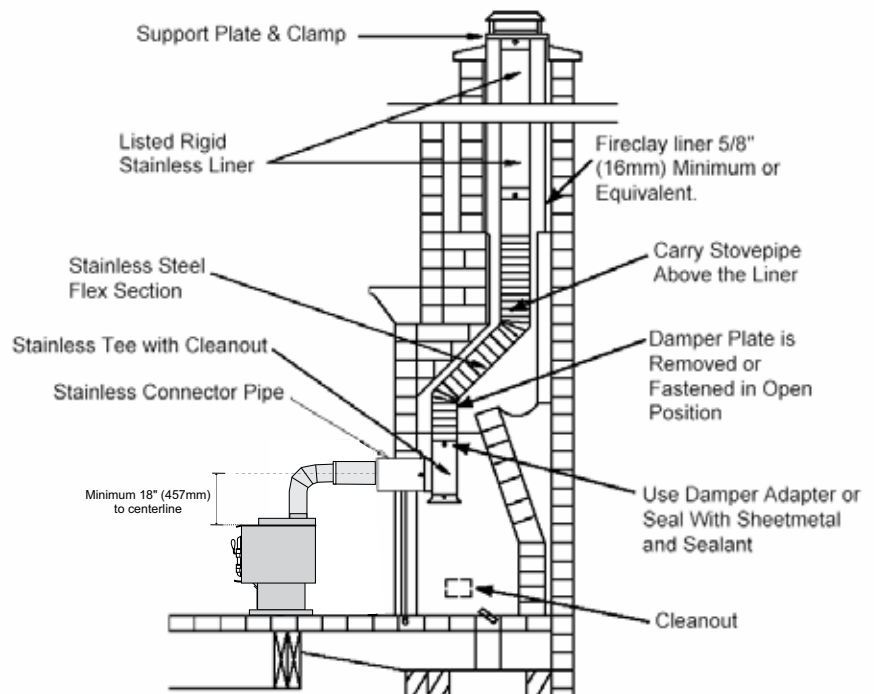

FACTORY BUILT CHIMNEY

When a metal prefabricated chimney is used, the manufacturer's installation instructions must be followed. You must also purchase and install the ceiling support package or wall pass-through and "T" section package, firestops (where needed), insulation shield, roof flashing, chimney cap, etc. Maintain proper clearance to the structure as recommended by the manufacturer. The chimney must be the required height above the roof or other obstructions for safety and proper draft operation. The space heater is to be connected to a factory-built chimney conforming to CAN/ULC-S629, Standard for 650°C Factory-Built Chimneys.

COMBUSTIBLE WALL CHIMNEY CONNECTOR PASS-THROUGHS

Method A: 12" (304.8 mm) Clearance to Combustible Wall Member:

Using a minimum thickness 3.5" (89 mm) brick and a 5/8" (15.9 mm) minimum wall thickness clay liner, construct a wall pass-through. The clay liner must conform to ASTM C315 (Standard Specification for Clay Fire Linings) or its equivalent. Keep a minimum of 12" (304.8 mm) of brick masonry between the clay liner and wall combustibles. The clay liner shall run from the brick masonry outer surface to the inner surface of the chimney flue liner but not past the inner surface. Firmly grout or cement the clay liner in place to the chimney flue liner.

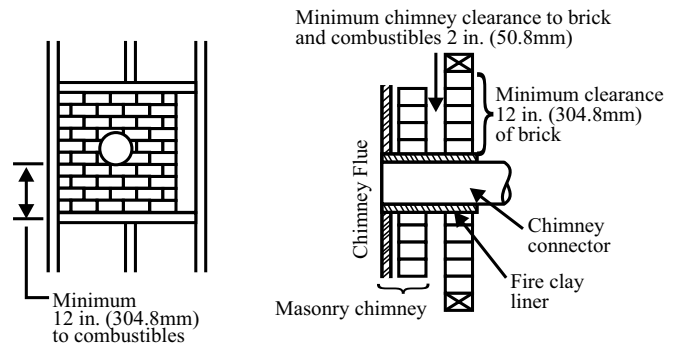

Method B: 9" (228.6 mm) Clearance to Combustible Wall Member:

Using a 6" (152.4 mm) inside diameter, listed, factory-built Solid-Pak chimney section with insulation of 1" (25.4 mm) or more, build a wall pass-through with a minimum 9" (228.6 mm) air space between the outer wall of the chimney length and wall combustibles. Use sheet metal supports fastened securely to wall surfaces on all sides, to maintain the 9" (228.6 mm) air space. When fastening supports to chimney length, do not penetrate the chimney liner (the inside wall of the Solid-Pak chimney). The inner end of the Solid-Pak chimney section shall be flush with the inside of the masonry chimney flue, and sealed with a non-water soluble refractory cement. Use this cement to also seal to the brick masonry penetration.

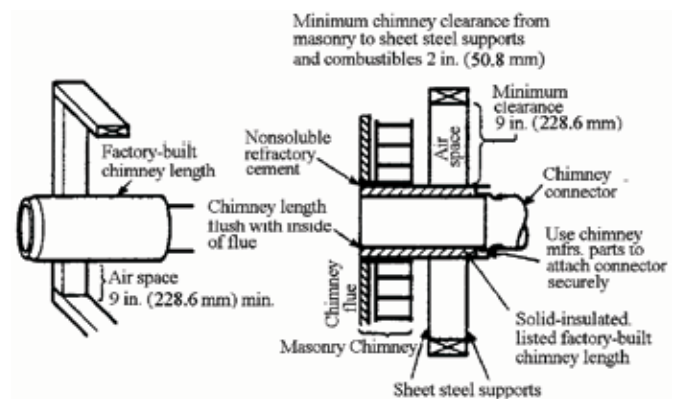

Method C: 6" (152.4 mm) Clearance to Combustible Wall Member:

Starting with a minimum 24 gage (.024" [.61 mm]) 6" (152.4 mm) metal chimney connector, and a minimum 24 gage ventilated wall thimble which has two air channels of 1" (25.4 mm) each, construct a wall pass-through. There shall be a minimum 6" (152.4 mm) separation area containing fiberglass insulation, from the outer surface of the wall thimble to wall combustibles. Support the wall thimble, and cover its opening with a 24-gage minimum sheet metal support. Maintain the 6" (152.4 mm) space. There should also be a support sized to fit and hold the metal chimney connector. See that the supports are fastened securely to wall surfaces on all sides. Make sure fasteners used to secure the metal chimney connector do not penetrate chimney flue liner.

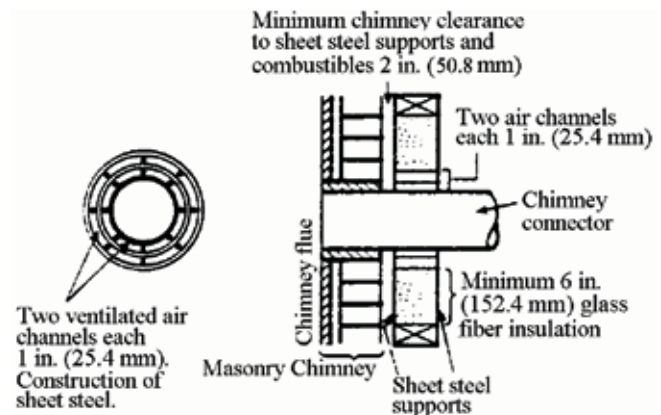

Method D: 2" (50.8 mm) Clearance to Combustible Wall Member:

Start with a solid-pak listed factory built chimney section at least 12" (304 mm) long, with insulation of 1" (25.4 mm) or more, and an inside diameter of 6" (2 inches [51 mm] larger than the 6" [152.4 mm] chimney connector). Use this as a pass-through for a minimum 24-gage single wall steel chimney connector. Keep solid-pak section concentric with and spaced 1" (25.4 mm) off the chimney connector by way of sheet metal support plates at both ends of chimney section. Cover opening with and support chimney section on both sides with 24 gage minimum sheet metal supports. See that the supports are fastened securely to wall surfaces on all sides. Make sure fasteners used to secure the metal chimney connector do not penetrate chimney flue liner.

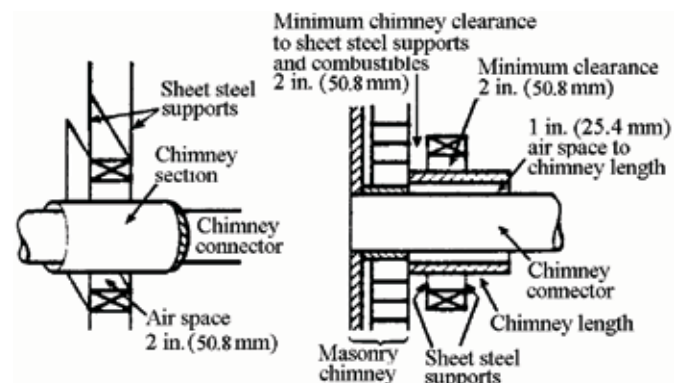

TABLE 1
MINIMUM RECOMMENDED FLUE HEIGHTS IN FEET
 (Measured from the top of the unit)

ELEVATION (FT) ABOVE SEA LEVEL	# OF ELBOWS						
	0	2 x 15°	4 x 15°	2 x 30°	4 x 30°	2 x 45°	4 x 45°
0-1000	12.0	13.0	14.0	15.0	18.0	16.0	20.0
1000-2000	12.5	13.5	14.5	15.5	19.0	16.5	21.0
2000-3000	13.0	14.0	15.0	16.0	19.5	17.0	21.5
3000-4000	13.5	14.5	15.5	17.0	20.0	18.0	22.5
4000-5000	14.0	15.0	16.0	17.5	21.0	18.5	23.0
5000-6000	14.5	15.5	17.0	18.0	21.5	19.0	24.0
6000-7000	15.0	16.0	17.5	18.5	22.5	20.0	25.0
7000-8000	15.5	16.5	18.0	19.0	23.0	20.5	25.5
8000-9000	16.0	17.0	18.5	20.0	24.0	21.0	26.5
9000-10000	16.5	17.5	19.0	20.5	24.5	22.0	27.0

NOTE: No more than two offsets (four elbows) allowed. Two 45° elbows equal one 90° elbow.

RECOMMENDED HEIGHTS FOR WOODSTOVE FLUE

Simple rules on draft. See Table 1.

- 1) At sea level minimum height is 12' straight.
- 2) Add the following vertical height to compensate for:
 45 deg. elbow = 1 ft.
 90 deg. elbow = 2 ft.
 "T" = 3 ft.
 Each foot of horizontal run = 2 ft.
- 3) Add 4% overall for each 1000' above sea level.

Example: a)
 1-1/2 ft. of horizontal run = 3 ft.
 one "T" = 3 ft.
 Total Addition (at sea level) = 6 ft.

Example: b)
 One 90 deg. elbow = 2 ft.
 2 ft. of horizontal run = 4 ft.
 one "T" = 3 ft.
 Total Addition (at sea level) = 9 ft.

Recommended Flue Height		
Elevation	Example a)	Example b)
0'	18'	21'
1000'	18.72'	21.84'
2000'	19.44'	22.68'
5000'	21.60'	25.20'
8000'	23.76'	27.72'

Draft is the force which moves air from the appliance up through the chimney. The amount of draft in your chimney depends on the length of the chimney, local geography, nearby obstructions and other factors. Too much draft may cause excessive temperatures in the appliance and may cause damage. An uncontrollable burn or excessive temperature indicates excessive draft. Inadequate draft may cause back puffing into the room and plugging of the chimney. Inadequate draft will cause the appliance to leak smoke into the room through appliance and chimney connector joints. Ensure the heater is installed in areas that are not too close to neighbors or in valleys that would cause unhealthy air quality or nuisance conditions.

WARNING:
DO NOT INSTALL IN SLEEPING ROOM

CAUTION: The structural integrity of the mobile home floor, wall and ceiling/roof must be maintained.