

City Series CV50E Direct Vent Gas Fireplace

MODEL	CV50E-NG	CV50E-LP
Fuel Type	Natural Gas	Propane
Minimum Supply Pressure	5" W.C. (1.25 kPa)	11" W.C. (2.73 kPa)
Manifold Pressure - High	3.8" W.C. (0.94 kPa)	10.5" W.C. (2.62 kPa)
Manifold Pressure - Low	1.1" W.C. (0.27 kPa)	2.9" W.C. (0.72 kPa)
Orifice Size -Altitude 0-4500 ft	# 36 DMS	# 52 DMS
Minimum Input Altitude 0-4500 ft. (0-1372m)	19,000 Btu/h (5.56 kW)	17,000 Btu/h (4.98 kW)
Maximum Input Altitude 0-4500 ft. (0-1372m)	35,000 Btu/h (10.25 kW)	33,000 Btu/h (9.66 kW)
Vent Sizing	5" Inner / 8" Outer	5" Inner / 8" Outer
CSA P.4.1.	57.49%	60.55%



NOTE: This model comes with a 5" inner and 8" outer collar (127 mm x 203 mm) which must be reduced to 4" inner x 6-5/8" outer (102 mm x 168 mm) in all applications when used as a power vent system. See power vent manual for details.

Dimensions

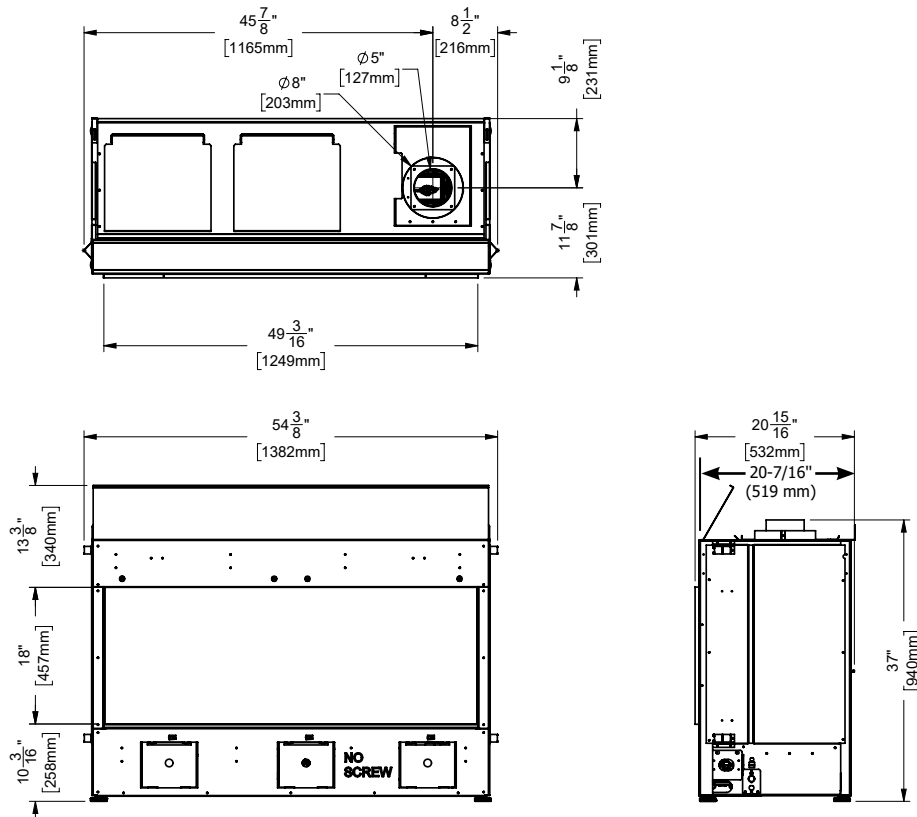

Note: Height Dimension is taken with leveling legs fully inserted and may vary depending on the height of the leveling legs, when unscrewed or extended.

Dimensions will appear as (inches)" / (metric) mm throughout this manual. The inches are rounded to the nearest 1/16" when converted, when greater accuracy is required, use the metric dimensions.

Note: These units are non-load bearing.

ALL PICTURES / DIAGRAMS SHOWN THROUGHOUT THIS MANUAL ARE FOR ILLUSTRATION PURPOSES ONLY. ACTUAL PRODUCT MAY VARY DUE TO PRODUCT ENHANCEMENTS.

Gas Connection - Bottom of Unit

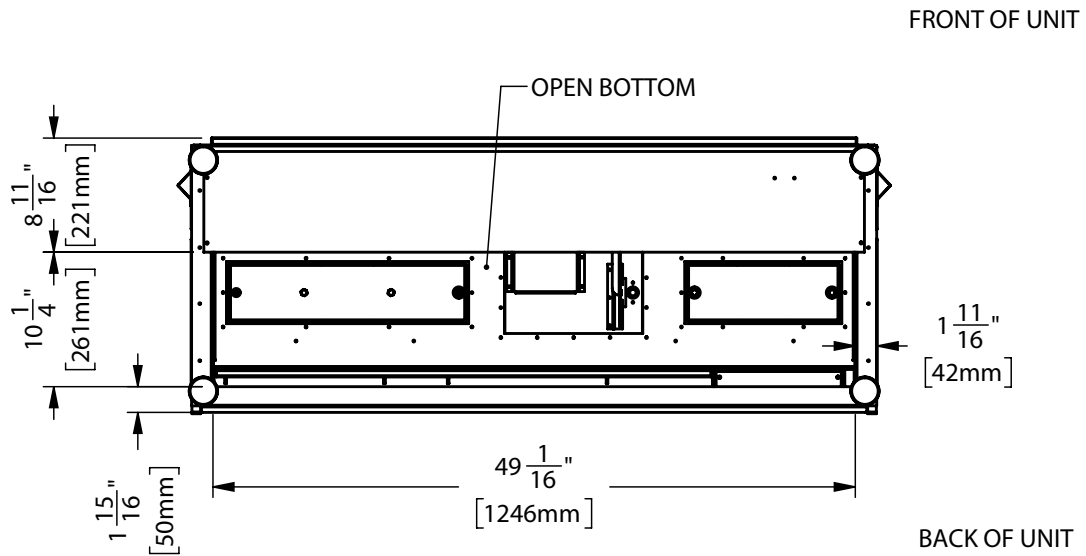

Gas Connection - Side of Unit

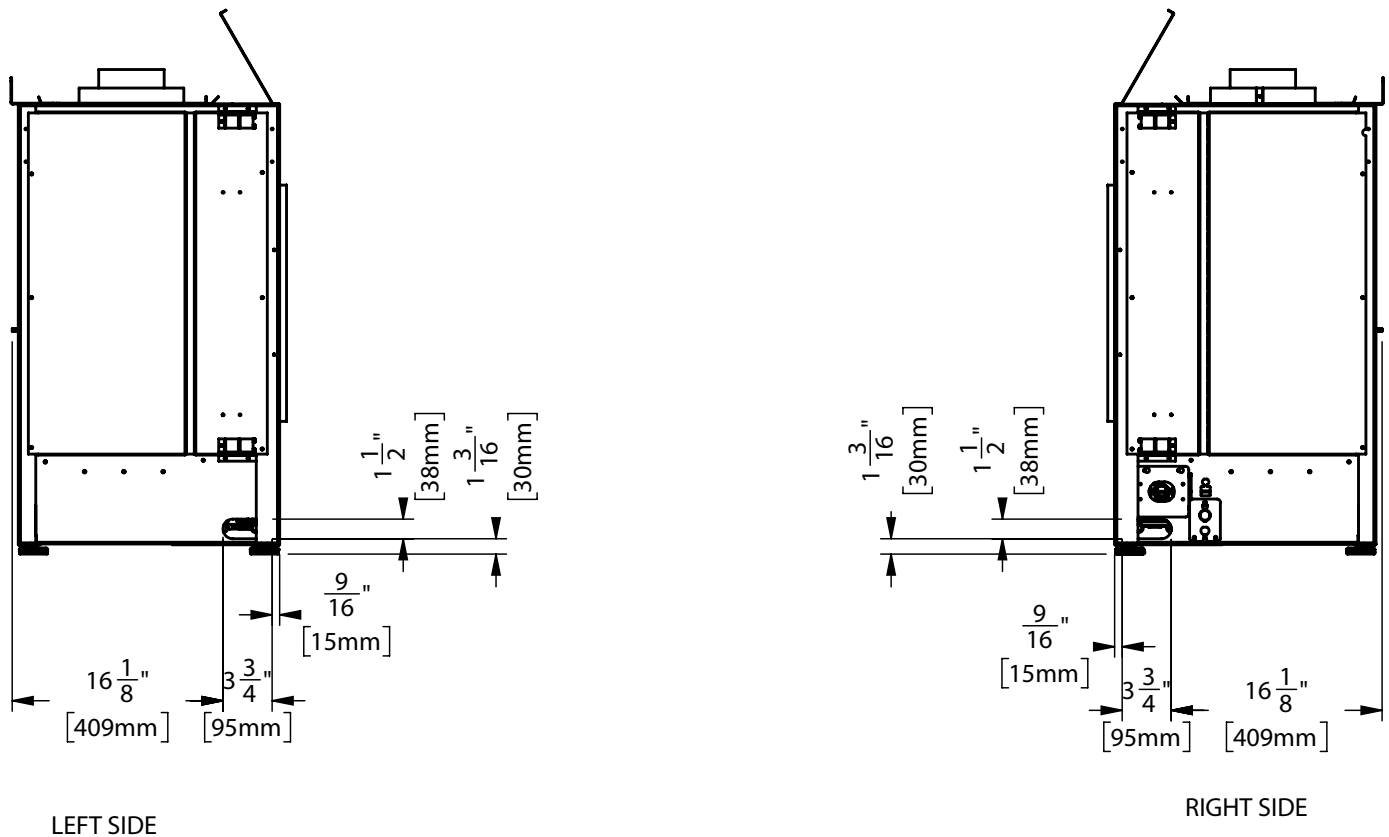

Electrical Connection - Bottom of Unit

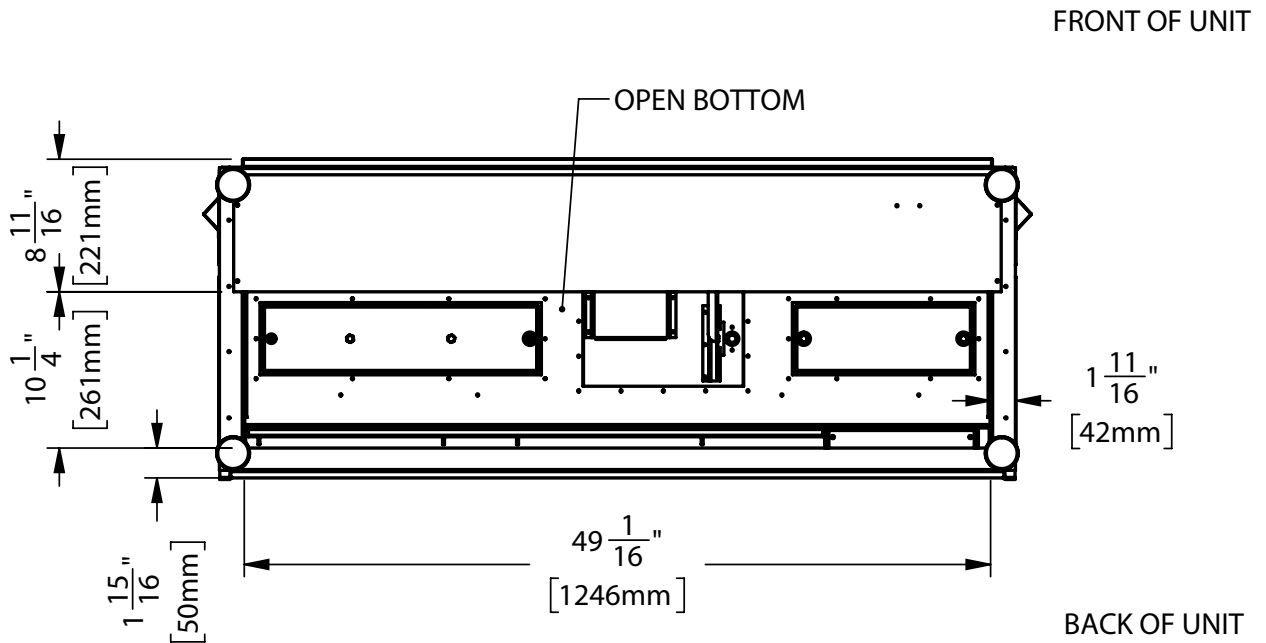

Electrical Connection - Side of Unit

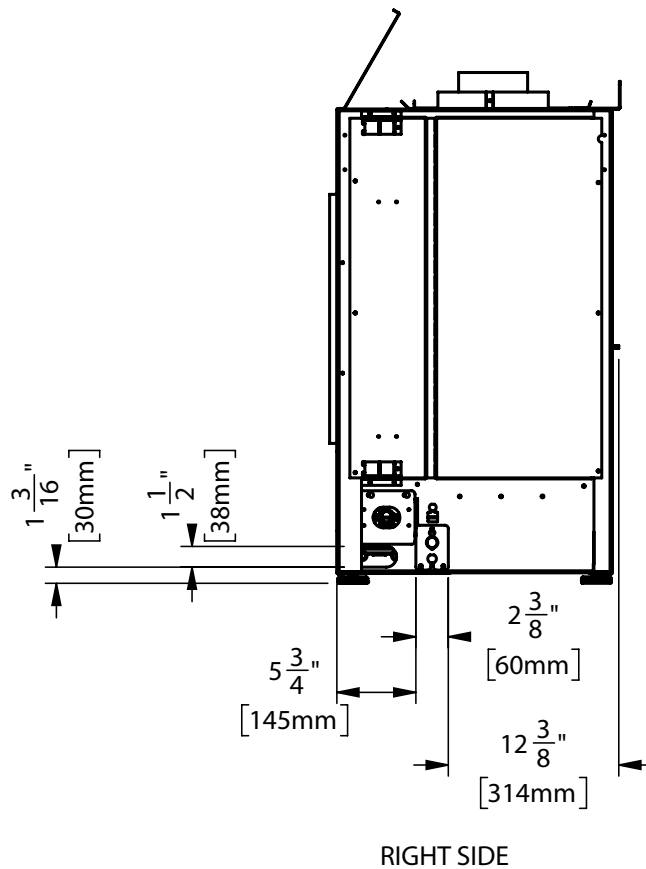

Clearances

Note: The clearances listed below are minimum distances unless otherwise stated.

A major cause of chimney-related fires is failure to maintain required clearances (air space) to combustible materials. It is of the greatest importance that this fireplace and vent system be installed only in accordance with these instructions.

Clearance	Dimension	Measured From:
A1: Mantel Height (min.)	**	Top of Fireplace Opening
A: From Floor (min.)	10-3/16" (462 mm)	Bottom of fireplace opening
B: Sidewall (on one side) min.	5" (127 mm)	Side of fireplace opening
B1: Sidewall (on one side) min.	24" (610 mm)	Side air outlet to side wall (min.)
C: Enclosure Width (min.)	54-3/8" (1381 mm)	Side of fireplace opening
D: Mantel Depth (max.)	**	
E: Alcove Width	92" (2337 mm)	Sidewall to sidewall (minimum)
F: Alcove Depth	35" (889 mm)	Front to unit (maximum)
G: Convection Air Outlet Opening Offset (min.)	*0-2" (0-51 mm)	Max. offset from top of chase enclosure
H: Convection Air Outlet	*152 in ² (981 cm ²)	
I: Framing Depth (min.)	20-7/16" (519 mm)	From back wall to chase front
J: Opening Height	18" (457 mm)	Bottom/top of fireplace opening
K: minimum clearance to ceiling	1-3/4" (44 mm)	Top of chase to ceiling
L: Chase Enclosure (min.)	62-7/8" (1597 mm)	From base of unit/floor to top of enclosure
M: Clearance to Sprinkler Head (min.)	36" (914mm)	Perpendicular from chase grill
Ceiling Height	81-1/4" (2064 mm)	From base of unit/floor to top of alcove
Hearth	0"	No hearth required

** See mantel clearances chart in the manual.

Flue Clearances to Combustibles	
Horizontal - Top	3" (76 mm)
Horizontal - Side	2" (51 mm)
Horizontal - Bottom	2" (51 mm)
Vertical	2" (51 mm)
Passing through wall/floor/ceiling - when firestop is used.	1-1/2" (38 mm)

Note: This appliance uses 5" x 8" (127 mm x 203 mm) venting for the Non Power Vent.

When installed as a power vent, the venting must be reduced to 4" inner x 6-5/8" outer (102 mm x 168 mm) in all applications. See required reducers required in this manual if using rigid/flex pipe.

***A minimum of 152 square inches of open area, not lower than 0-2" from top of enclosure, required for all installations.**

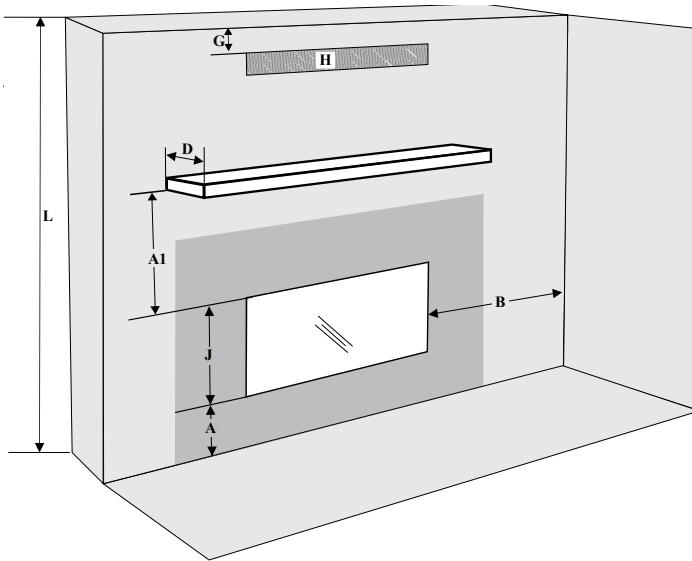

Caution Requirements

The top, back and sides of the fireplace are defined by standoffs. The metal ends of the standoff may **NOT** be recessed into combustible construction.

WARNING

Fire hazard is an extreme risk if these clearances (air space) to combustible materials are not adhered to. It is of greatest importance that this fireplace and vent system be installed only in accordance with these instructions.

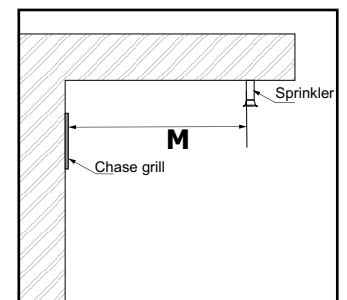

Side view

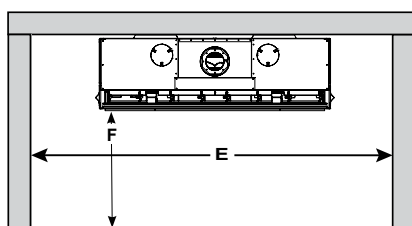

Alcove

Clearances

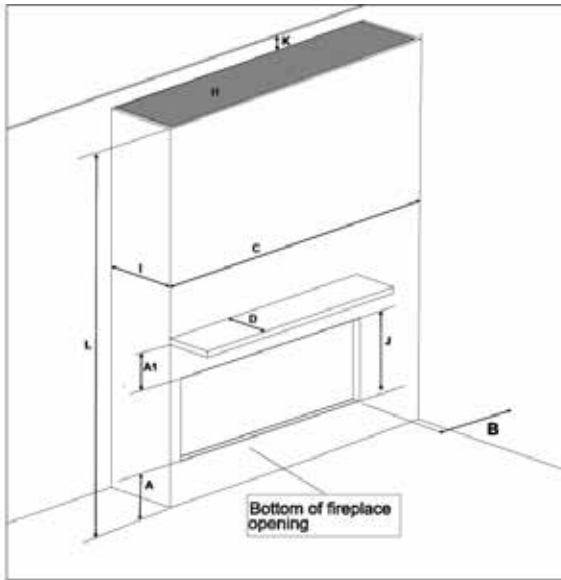

Floor to ceiling with top opening.

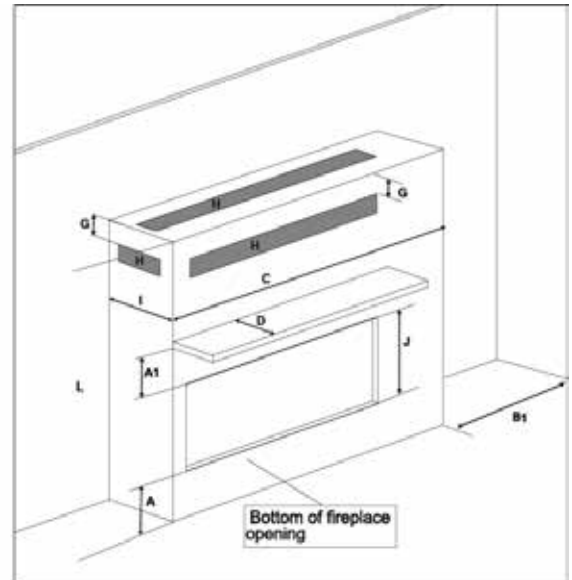

Full framing with vents in front, 2 sides, or top.

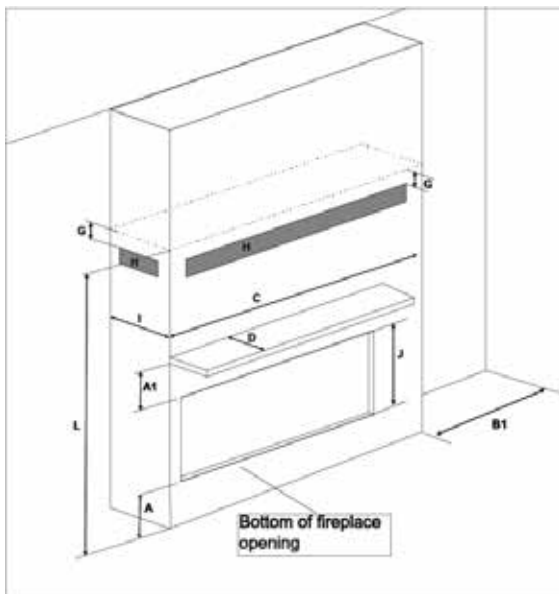

Full framing with low vents in front or 2 sides.

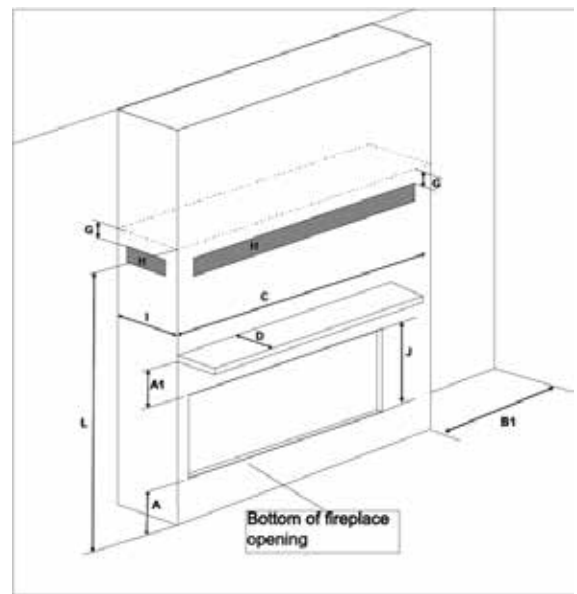

Full framing with vents in front or 2 sides.

The ventilation opening may only be placed above, on both sides and in front as shown above. Ventilation grills can never be placed behind the appliance.

Framing Dimensions

NOTE: Framing may be constructed of combustible material (i.e. 2 x 4/2 x 6) and does not require steel studs.

Framing Dimensions	Description	CV50E
A	Framing Height	2 x 4 : 44-3/4" (1137 mm) 2 x 6 : 51-7/8" (1318 mm)
B*	Framing Width	54-3/8" (1381 mm)
C*	Framing Depth	20-7/16" (519 mm)
D	Minimum Height to Combustibles	62-7/8" (1597 mm)
E	Corner Wall Depth	66" (1676 mm)
F	Corner Facing Wall Depth	93-3/8" (2372 mm)
G	Vent Centerline Height	45-3/4" (1162 mm)

** See manual for alternate Gas/ Electrical connection options

The lift handles add approximately 4 inches to the width of the appliance. If the appliance will be lifted off the ground and slid into the framed opening, we suggest changing the framing width from 54-3/8" (1381 mm) to 58-3/8" (1483 mm) to allow the appliance to slide into position with the handles on, or creating a platform in front of the framed opening where the lift handles can be removed prior to installation. If the framing is raised off the ground you can install it after the appliance is in place with handles removed to maintain the framing width of 54-3/8" (1381 mm). Ensure that the wood base for the appliance is strong enough to support its shipping weight of 480 pounds.

Note: A combined minimum of 152 square inches of open area is required for the convection air outlet to cool the enclosure. Ensure clearances for convection air outlets are met. See clearances in this manual for different ways to achieve this.

Note: This appliance must be installed on a solid surface such as a plywood floor which must be the full width and depth of the appliance.

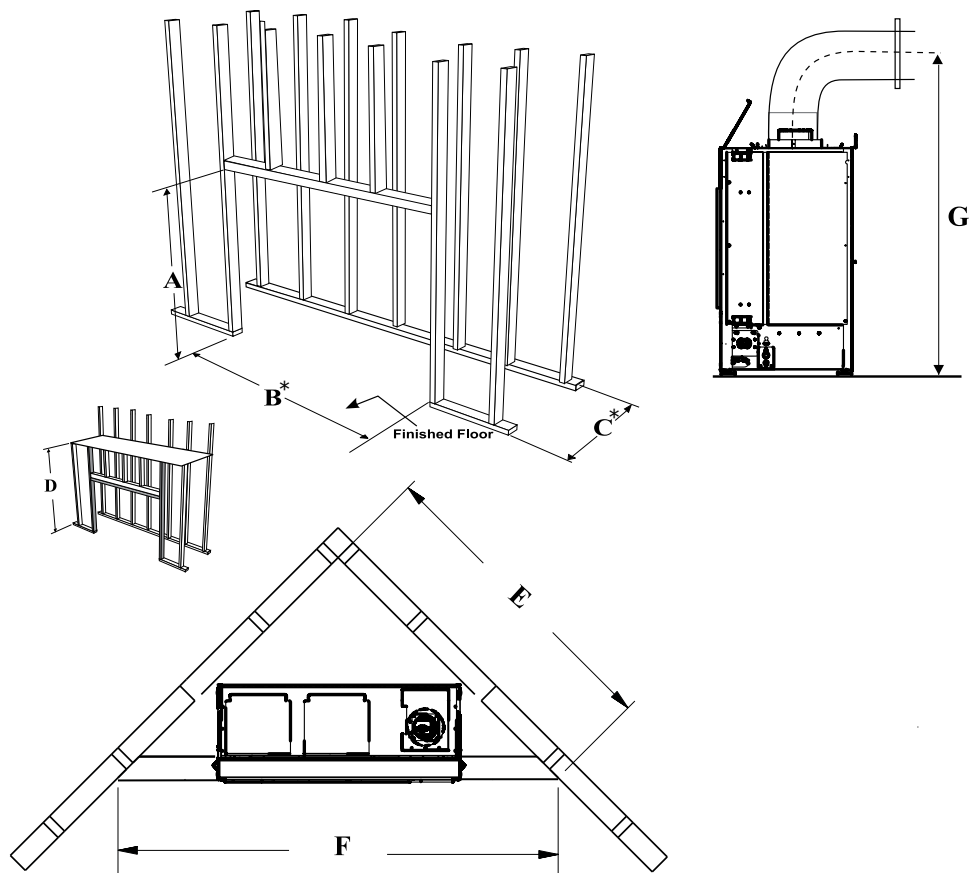

* The framing depth/width does not take into account drywall/wood or similar materials against the back /side wall. The framing depth will need to change based on the thickness of the material.
Example: B - 54-3/8" framing width + 1/2" drywall per side = 55-3/8")
Example: C - 20-7/16" framing depth + 1/2" drywall = 20-15/16")

Chase Vent Installation Part #482-991 (White)

In this application, both the flange and screws to secure the chase vent are exposed as this chase vent is designed to be installed after the finished facing has been placed on the wall.

Framing Opening must be between 3" (76 mm) and 3-1/2" (89 mm) tall, and at least 51-1/2" (1308 mm) wide to accommodate the Chase vent. The top of the chase vent opening must be 2" (51 mm) or less from the top of the chase enclosure.

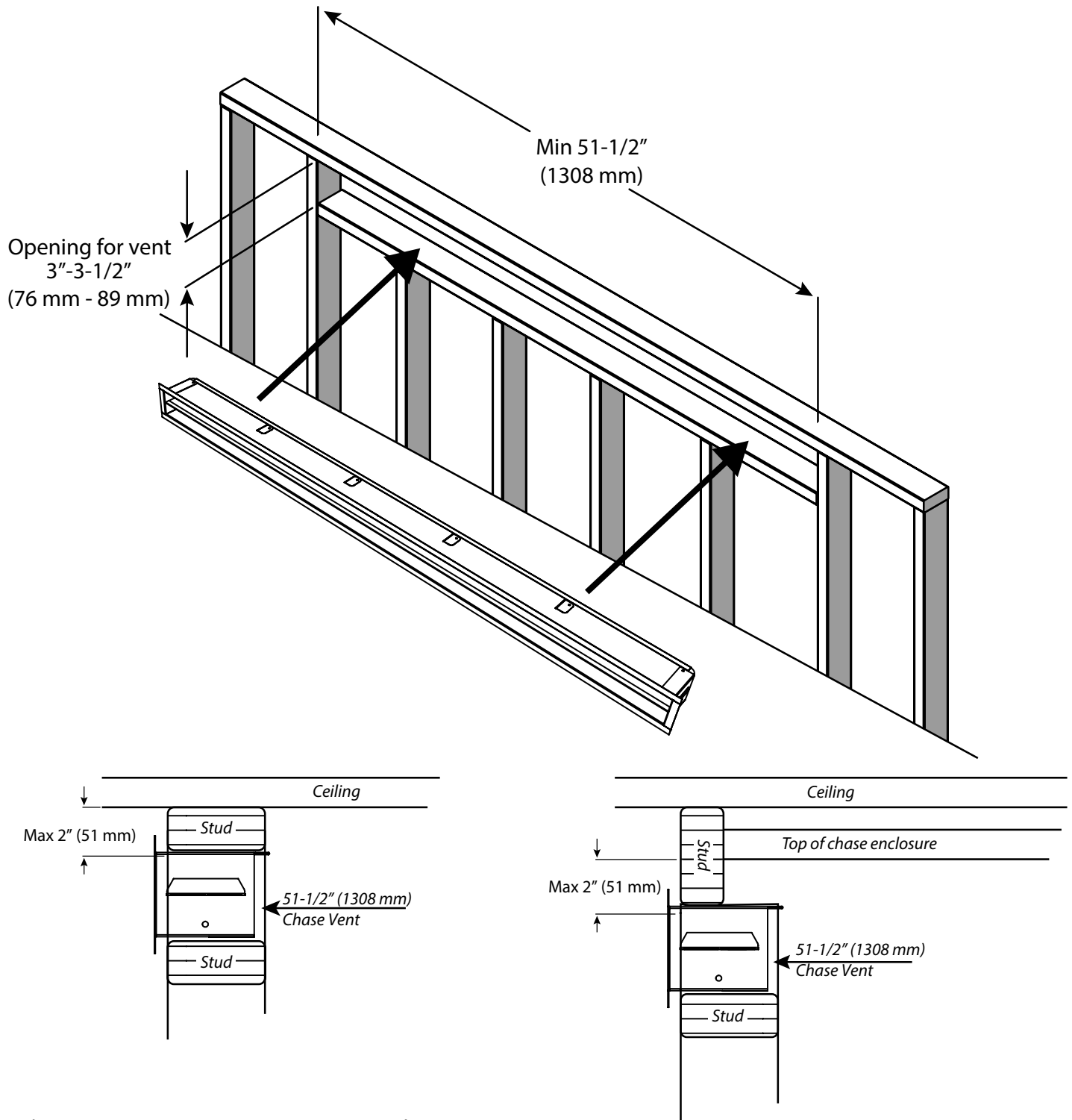

Typical Installations

Flush Install

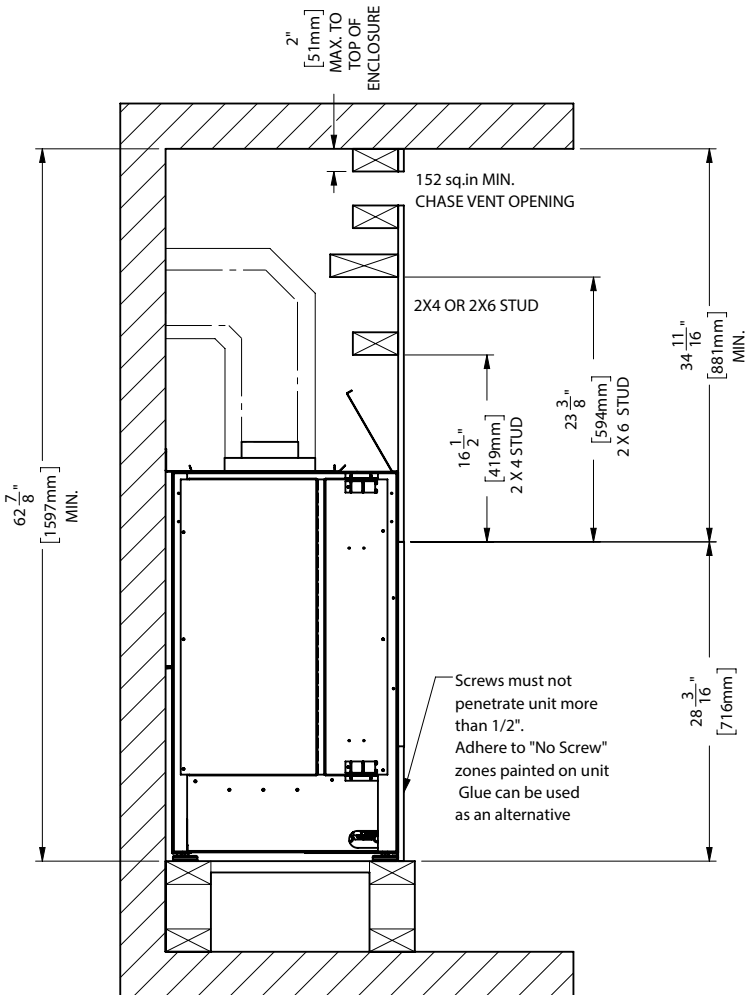

Recessed Install

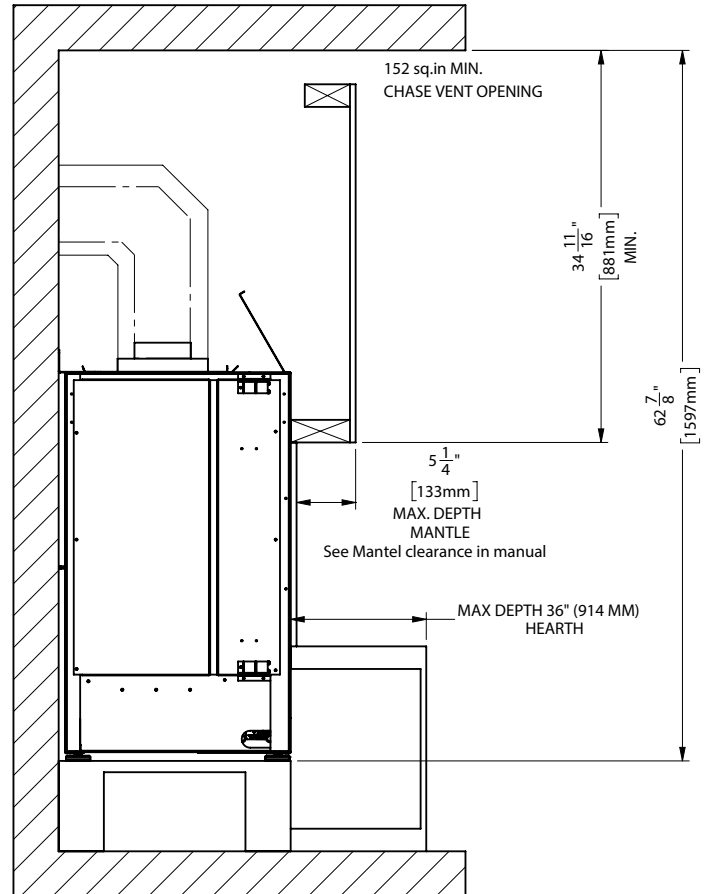

Typical Installations

Maximum TV Recess

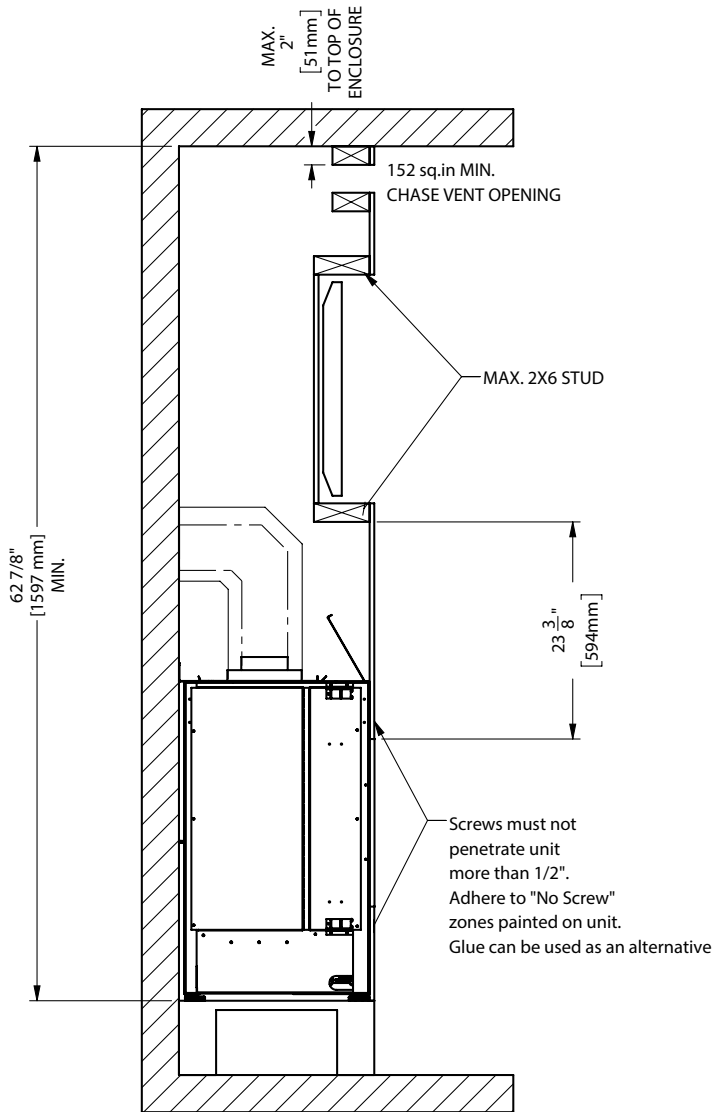

Flush TV with Hearth

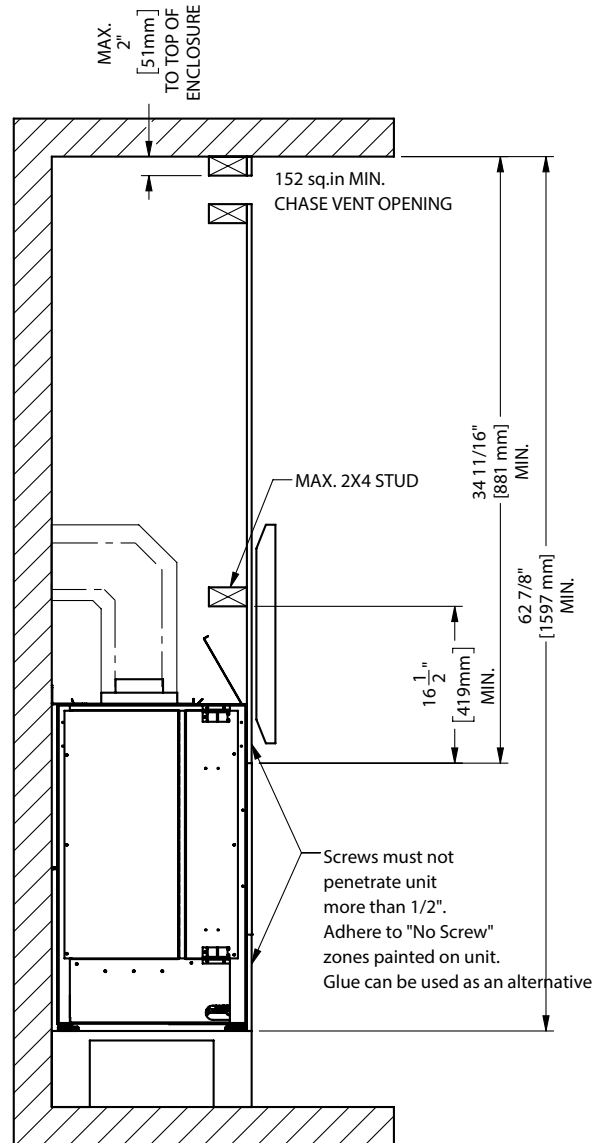

Note: The TV mounting bracket cannot be secured directly to the appliance. It must be secured to framing. The TV depicted in the picture may need to be higher depending on the style of TV mounting bracket used.

Horizontal Terminations - Flex Vent 5" x 8" (Non Power Vent)

These venting systems, in combination with the CB50E Direct Vent Gas Fireplace, has been tested and listed as a direct vent heater system by Intertek. The location of the termination cap must conform to the requirements in the Vent Terminal Locations diagram in "Exterior Vent Termination Locations" section.

Regency® Direct Vent (Flex) System Termination Kits include all the parts needed to install the CB50E using a flexible vent.

FPI Kit #	Length	Contains:
#946-615	4 Feet	1) 8" flexible liner (Kit length) 2) 5" flexible liner (Kit length) 3) spring spacers
#946-618	6 Feet	4) thimble 5) AstroCap XL termination cap 6) screws
#946-616	10 Feet	7) tube of Mill Pac 8) plated screws 9) S.S. screws #8 x 1-1/2" drill point 10) vinyl siding standoff

Notes:

- Liner sections should be continuous without any joints or seams.
- Only Flex pipe purchased from Regency® may be used for Flex installations
- Horizontal vent must be supported every 3 feet.
- Regency® Direct Vent System (Flex) is only approved for horizontal terminations.
- Flex system can only be used up to a maximum continuous vent length of up to 10 feet. If longer runs are required, rigid pipe must be used.

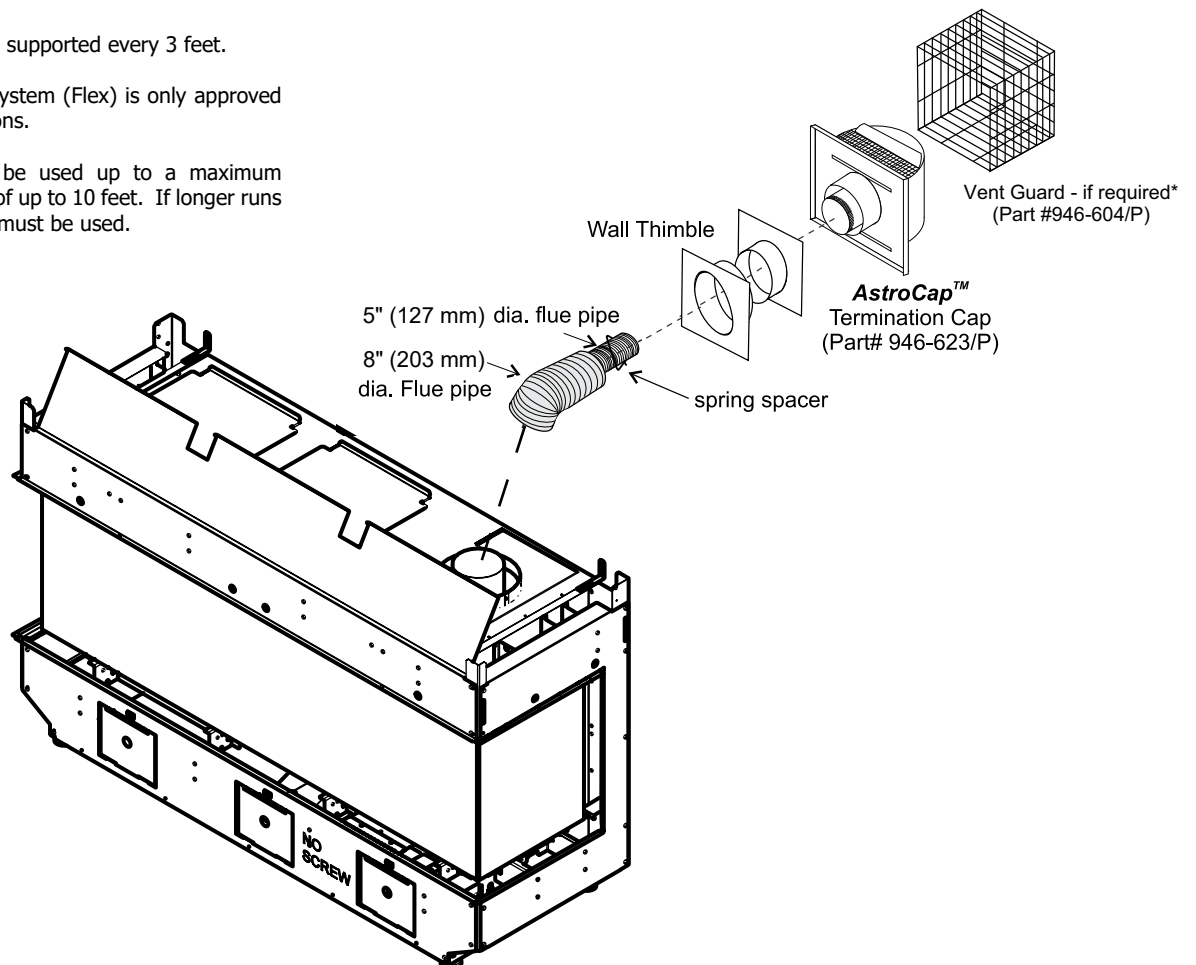

Horizontal Terminations - Flex Vent 5" x 8" (Non Power Vent)

Unit Installation with Horizontal Termination - 5" x 8" Venting (Flex Vent Systems)

Minimum Vent Clearances to Combustibles

* Clearances noted below must be maintained; except when passing through a wall, ceiling or at the termination where the use of a firestop or wall thimble reduces clearance to 1-1/2" (38mm).

Horizontal Top	3" (76mm)
Horizontal Side	2" (51mm)
Horizontal Bottom	2" (51mm)
Vertical Vent	2" (51mm)

Below are the recommended framing dimensions (inside measurements) for the 5" x 8" rigid vent terminations - for use with a firestop or wall thimble.

Recommended Framed Opening Size	
Vent Size	Framing Size
5" x 8"	11" x 11"

1. Locate the unit in the framing, rough in the gas (preferably on the right side of the unit). Locate the centerline of the termination and mark wall accordingly. Cut an square hole in the wall - see chart (inside dimension).

Note: If installing termination on a siding covered wall, a vinyl siding standoff or vinyl furring strips must be used to ensure that the termination is not recessed into the siding.

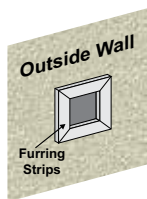

2. Level the fireplace and fasten it to the framing using nails or screws through the nailing strips.
3. Assemble the vent assembly by applying Mill-Pac to the inner flue collar of the termination and slipping the inner flex liner over it at least 1-3/8" (35mm). Fasten with the 3 screws (drilling pilot holes will make this easier). Apply Mill-Pac to the outer flex pipe and slip it over the outer flue collar of the vent terminal at least 1-3/8" (35mm) and fasten with the 3 screws.

NOTE: Horizontal sections must be supported at intervals not exceeding 3 feet (0.9 meter). (Flame picture and performance will be affected by sags in the liner).

4. Separate the 2 halves of the wall thimble and securely fasten the one with the tabs to the outside wall making sure that the tabs are on top and bottom. Fasten the other thimble half to the inside wall. The thimble halves slip inside each other and can be adjusted for 2 x 4 or 2 x 6 walls.
5. Slip the assembled liner and termination assembly through the thimble making sure the termination cap faces up (there are markings on the cap that show which way is up). This will position the termination cap with proper down slope for draining water. Fasten the cap to the outer wall with the 4 supplied screws.
6. Pull the centre inner and outer flex liner out enough to slip over the flue collars of the fireplace. (You may wish to cut the liner shorter to make it more workable.) Do not bend liner more than 90°. The liners must slip over the collars a minimum of 1-3/8".
7. Apply Mill-Pac over the fireplace inner flue collar and slip the inner flex liner down over it and attach with 3 supplied screws.
8. Do the same with the outer flue collar and outer flex liner.
9. Apply a bead of silicone between the thimble and termination and around the outer edge of the terminal at the wall in order to keep the water out.

IMPORTANT: Do not locate termination hood where excessive snow or ice buildup may occur. Be sure to check vent termination area after snow falls, and clear to prevent accidental blockage of venting system. When using snow blowers, make sure snow is not directed towards vent termination area.

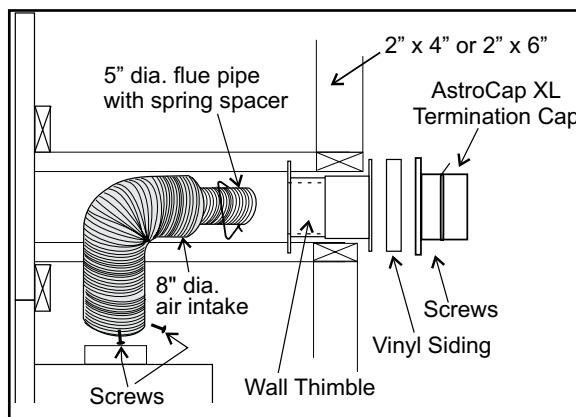

Diagram 2

ASTROCAP XL DIMENSIONS (946-623/P)

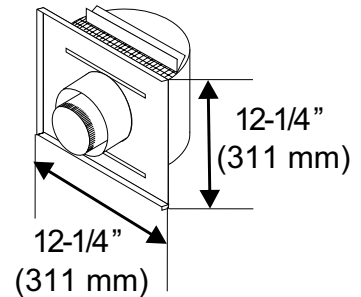

Diagram 1

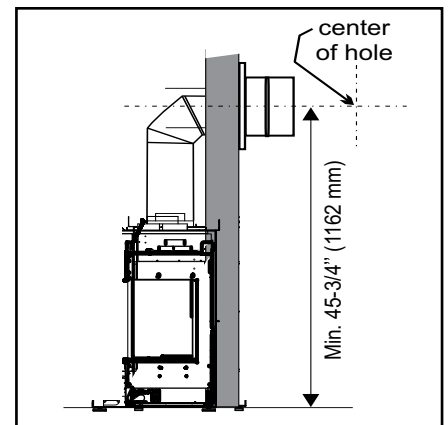

Diagram 3

Venting Introduction (Non Power Vent)

The CV50E uses the "balanced flue" technology co-axial system. The inner liner vents products of combustion to the outside while the outer liner draws outside combustion air into the combustion chamber, thereby eliminating the need to use heated room air for combustion and losing warm room air up the chimney.

The gas appliance and vent system must be vented directly to the outside of the building, and never be attached to a chimney serving a separate solid fuel or gas burning appliance. Each direct vent gas appliance must use its own separate vent system. Common vent systems are prohibited.

NOTE These flue pipes must not be connected to any other appliance.

Venting Arrangement for Horizontal Terminations (Rigid and Flex)

The diagram shows all allowable combinations of vertical runs with horizontal terminations, using one 90° elbow (two 45° elbows equal one 90° elbow).

NOTES

- Must use optional rigid pipe adapter (part# 770-994) when using rigid pipe venting systems.
- For horizontal terminations, the Regency direct vent flex system may be used for installations with a maximum continuous vent length of up to 10 feet. If longer runs are required, rigid pipe must be used.

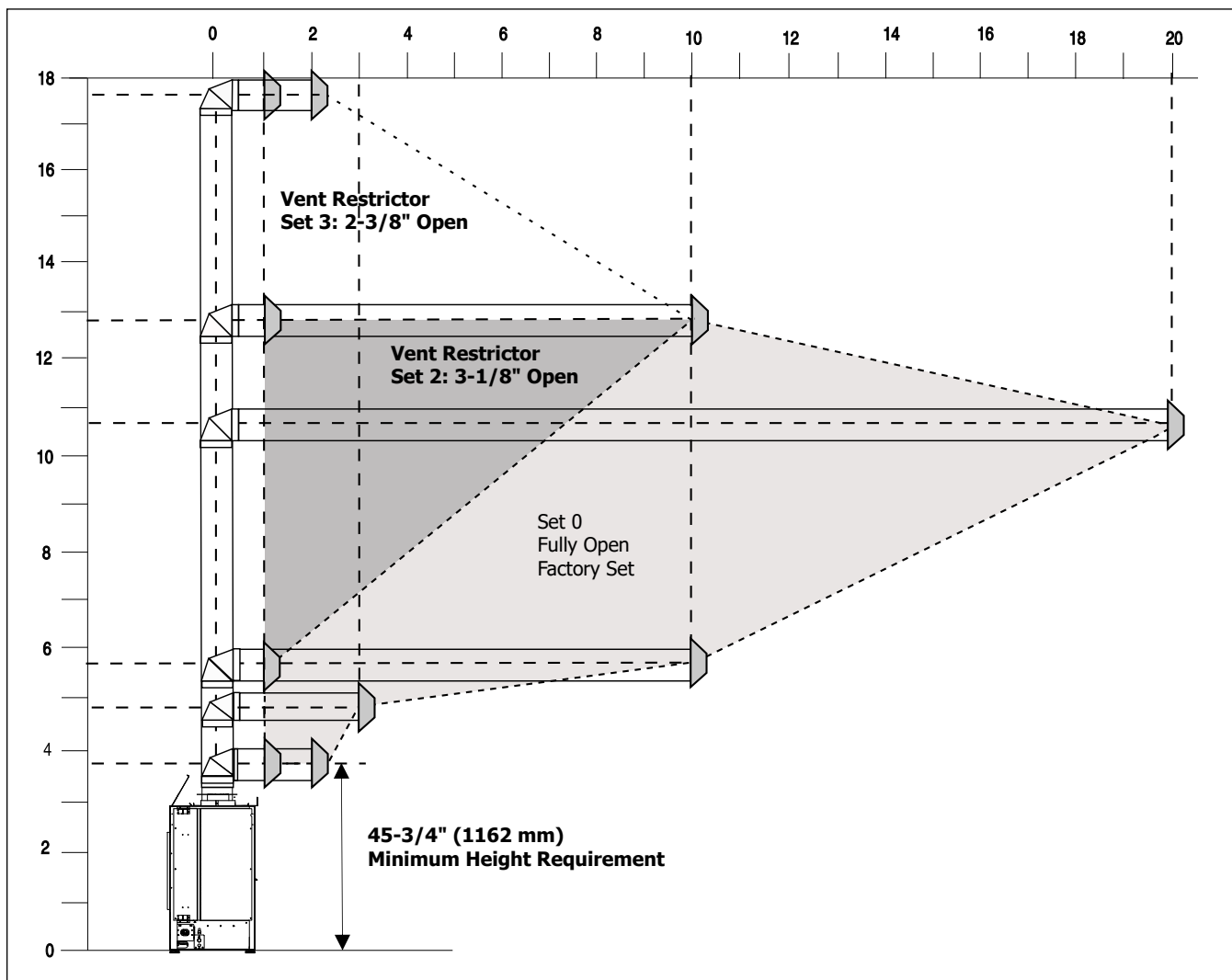

VENT RESTRICTOR SETTING:

Vent restrictor factory set at Set 0.

Refer to the "Vent Restrictor Position" section for details on how to change the vent restrictor from the factory setting of Set 0 to Set 3 if required.

- Maintain clearances to combustibles as listed in "Clearances" section
- Horizontal vent must be supported every 3 feet.
- Firestops are required at each floor level and whenever passing through a wall.
- A vent guard should be used whenever the termination is lower than the specified minimum or as per local codes.

Horizontal Terminations - Rigid Pipe 5" x 8" (Non Power Vent)

The minimum components required for a basic horizontal termination are:

- 1 Horizontal Termination Cap
- 1 Rigid Pipe Adaptor (770-994)
- 1 Wall Thimble
- 1 Length of pipe to suit wall thickness (see chart)

Wall thickness is measured from the back standoffs to the inside mounting surface of termination cap. For siding other than vinyl furring strips may be used, instead of the vinyl siding standoff, to create a level surface to mount the vent terminal. The Terminal must not be recessed into siding. Measure the wall thickness including furring strips.

If a Vinyl Siding Standoff is required (it must be used with vinyl siding), measure to outside surface of wall without siding and add 2 inches.

Flat Wall Installation	
Wall Thickness (inches)	Vent Length Required (inches)
4" - 5-1/2"	6"
7" - 8-1/2"	9"
10" - 11-1/2"	12"
9" - 14-1/2"	11" - 14-5/8" Adj. Pipe
15" - 23-1/2"	17" - 24" Adj. Pipe

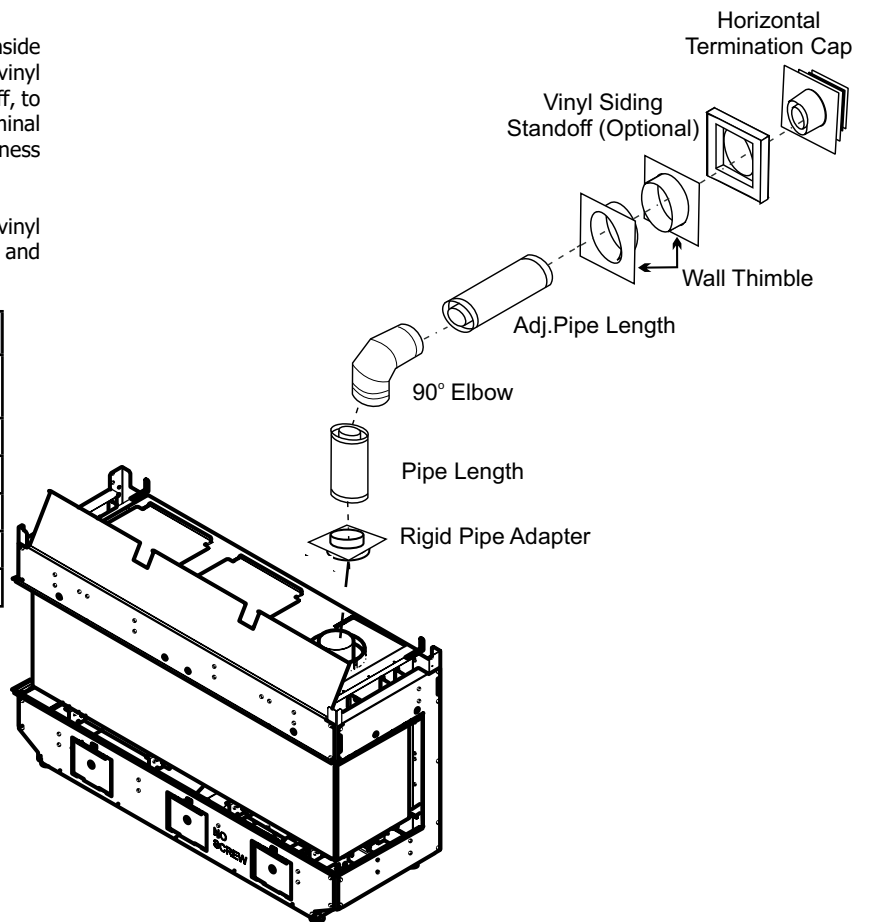

WARNING:

Do not combine venting components from different venting systems.

However use of the the AstroCap™ and FPI Riser is acceptable with all systems.

This product has been evaluated by Intertek for using a Rigid Pipe Adaptor in conjunction with DuraVent Direct-Vent, Selkirk Direct-Temp, Ameri Vent Direct Venting, ICC Excel Direct, Olympia Ventis DV, and Security Secure Vent systems. Use of these systems with the Rigid Pipe adaptor is deemed acceptable and does not affect the Intertek WHI listing of components.

***Unit is not exactly as shown.**

When using Rigid Vent other than Simpson Dura-Vent, 3 screws must be used to secure rigid pipe to adaptor.

The FPI AstroCap™ and FPI Riser Vent terminal are certified for installations using FPI venting systems as well as Simpson Dura-Vent® Direct Vent, American Metal Products Ameri Vent Direct Vent, Security Secure Vent®, ICC Excel, Olympia Ventis DV, Selkirk Direct-Temp. AstroCap™ is a proprietary trademark of FPI Fireplace Products International Ltd. Dura-Vent® and Direct Vent are registered and/or proprietary trademarks of Simpson Dura-Vent Co. Inc.

Unit Installation with Horizontal Termination (Non Power Vent)

5" x 8" Venting (Rigid Vent Systems) Minimum Vent Clearances to Combustibles

* Clearances noted below must be maintained; except when passing through a wall, ceiling or at the termination where the use of a firestop or wall thimble reduces clearance to 1-1/2" (38mm).

Horizontal Top*	3" (76mm)*
Horizontal Side	2" (51mm)
Horizontal Bottom	2" (51mm)
Vertical Vent	2" (51mm)

Below are the recommended framing dimensions (inside measurements) for the 5" x 8" rigid vent terminations - for use with a firestop or wall thimble.

Install the vent system according to the manufacturer's instructions included with the components.

1. Set the unit in its desired location. Check to determine if wall studs or roof rafters are in the way when the venting system is attached. If this is the case, you may want to adjust the location of the unit. Rough in the gas preferably on the right side of the unit and the electrical (junction block is on the left side) on the left.
2. Direct Vent pipe and fittings are designed with special twist-lock connections to connect the venting system to the appliance flue outlet. A twist-lock appliance adaptor is required.
3. In conjunction with the Approved Vent system, install the adaptor after the unit is set in its desired location. Slip the adaptor over the existing inner and outer flue collar. Fasten to the outer collar only with the 3 supplied screws (drilling pilot holes will make this easier).
4. Level the fireplace and fasten it to the framing using nails or screws through the top and side nailing strips.

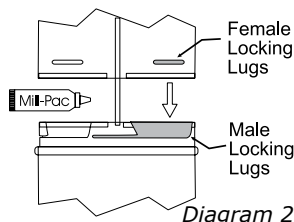

Diagram 2

5. Assemble the desired combination of pipe and elbows to the appliance adaptor and twist-lock for a solid connection.

Note: For best results and optimum performance with each approved venting system, it is highly recommended to apply "Mill-Pac" sealant (supplied) to every inner pipe connection. Failure to do so may result in drafting or performance issues not covered under warranty.

Horizontal runs of vent must be supported every

3 feet (0.9meter). Wall straps are available for this purpose.

6. Mark the wall for a square hole--see chart to left for size. The center of the square hole should line up with the center-line of the horizontal pipe. Cut and frame the square hole in the exterior wall where the vent will be terminated. See diagram 54 for center line requirements.

If the wall being penetrated is constructed of non-combustible material, i.e. masonry block or concrete, an 8" (203mm) diameter hole is acceptable.

Notes:

- a) The horizontal run of vent must be level, or have a 1/4 inch rise for every 1 foot of run towards the termination. Never allow the vent to run downward. This could cause high temperatures and may present the possibility of a fire.
- b) The location of the horizontal vent termination on an exterior wall must meet all local and national building codes, and must not be blocked or obstructed. See "Exterior Vent Termination Locations" section for more details.

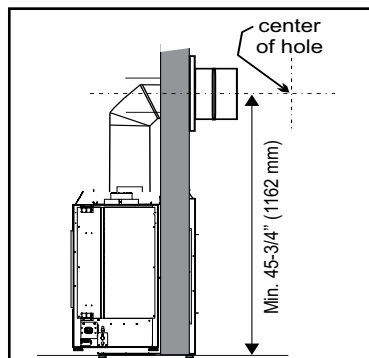

Diagram 3

c) Snorkel Terminations:

For installations requiring a vertical rise on the exterior of the building, 14-inch and 36-inch tall Snorkel Terminations are available, as well as the standard Riser Vent. Follow the same installation procedures as used for standard Horizontal Termination. NEVER install the snorkel upside down.

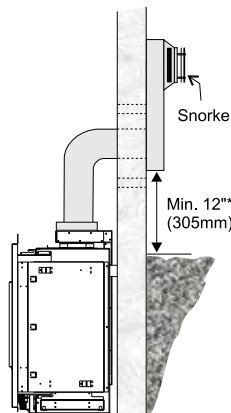

Diagram 4

*As specified in CSA B149.1 Installation Code. Local codes or regulations may require different clearances.

Below Grade Snorkel Installation

If the snorkel termination must be installed below grade, i.e. basement application, proper drainage must be provided to prevent water from entering the snorkel termination. See diagram 56. Do not attempt to enclose the snorkel within the wall or any other type of enclosure.

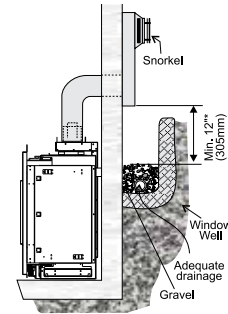
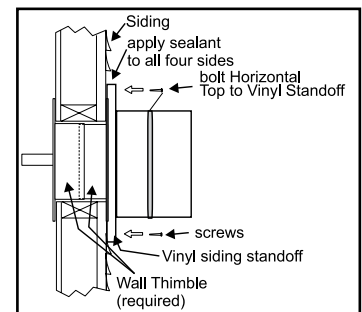

Diagram 5

7. Ensure that the pipe clearances to combustible materials are maintained (Diagram 55). Install the termination cap.

Note: If installing termination on a vinyl siding covered wall, a vinyl siding standoff or furring strips must be used to ensure that the termination is not recessed into the siding.

The four wood screws provided should be



replaced with appropriate fasteners for stucco, brick, concrete, or other types of sidings.

8. Before connecting the horizontal run of vent pipe to the vent termination, slide the Wall Thimble over the vent pipe. The wall thimble is required for all horizontal terminations.
9. Slide the appliance and vent assembly towards the wall carefully inserting the vent pipe into the vent cap assembly. It is important that the vent pipe extends into the vent cap sufficient distance so as to result in a minimum pipe overlap of 1-1/4 inches (32mm). Secure the connection between the vent pipe and the vent cap.
10. Install wall thimble in the center of the framed hole and attach with wood screws.

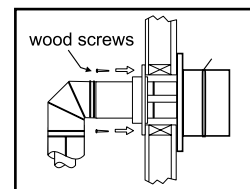

Horizontal Terminations - Rigid/Flex Pipe 5" x 8" (Non Power Vent)

The diagrams below show examples of horizontal termination arrangements using one, two, or three 90° elbows (two 45° elbows equal one 90° elbow).

1. A maximum of three 90° elbows are permitted.
 2. Minimum distance between elbows is 1 ft. (305mm).
- Maintain clearances to combustibles as listed in the "Clearances" section.
 - Horizontal vent must be supported every 3 feet.
 - Firestops are required at each floor level and whenever passing through a wall.
 - Must use optional rigid pipe adaptor (Part# 770-994) when using rigid pipe vent systems.
 - A vent guard should be used whenever the termination is lower than the specified minimum or as per local codes.
 - Flex system can only be used up to 10 feet - otherwise rigid venting must be used.

Horizontal Venting with Two 90° Elbows

One 90° elbow = Two 45° elbows.

Option	V	H + H1	With these options, maximum total pipe length is 30 feet with minimum of 6 feet total vertical and maximum 8 feet total horizontal. Please note minimum 1 foot between 90° elbows is required.
A)	1' Min.	2' Max.	
B)	2' Min.	4' Max.	
C)	3' Min.	5' Max.	
D)	4' Min.	6' Max.	
E)	5' Min.	7' Max.	
F)	6' Min.	8' Max.	
Restrictor Set 0 - Factory Setting			

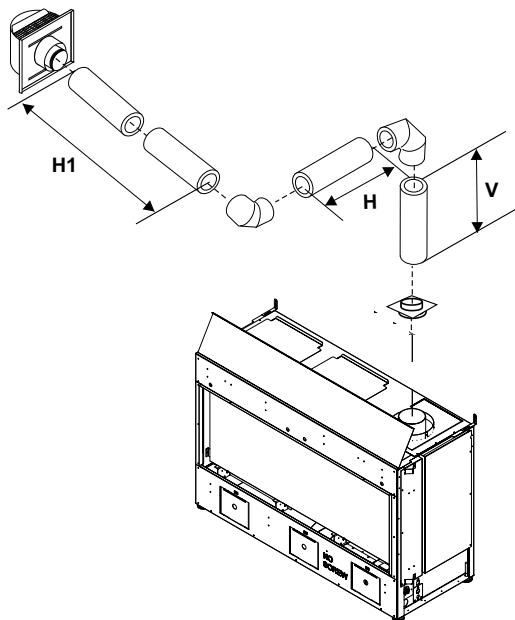

Horizontal Venting with Three 90° Elbows

One 90° elbow = Two 45° elbows.

Option	V	H	V + V1	H + H1	With these options, max. total pipe length is 30 feet with min. of 12 feet total vertical and max. 9 feet total horizontal. Please note min. 1 foot between 90° elbows is required.
A)	1' Min.	1' Max.	2' Min.	2' Max.	
B)	1' Min.	2' Max.	3' Min.	3' Max.	
C)	2' Min.	2' Max.	5' Min.	4' Max.	
D)	3' Min.	2' Max.	7' Min.	5' Max.	
E)	4' Min.	3' Max.	9' Min.	6' Max.	
F)	5' Min.	4' Max.	10' Min.	7' Max.	
G)	6' Min.	5' Max.	11' Min.	8' Max.	
H)	7' Min.	6' Max.	12' Min.	9' Max.	
Restrictor Set 0 - Factory Setting					

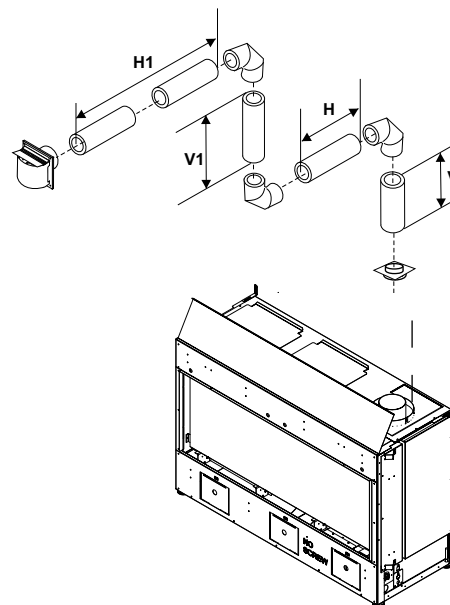

Vertical Terminations - Rigid Pipe 5" x 8" (Non Power Vent)

The minimum components required for a basic vertical termination are:

- 1 Vertical Termination Cap
- 1 Rigid Pipe Adaptor (770-994)
- 1 Ceiling Firestop
- 1 Flashing
- 1 Storm Collar
- 1 Length of pipes to suit wall thickness & vent run (see chart)

Galvanized pipe is desirable above the roofline due to its higher corrosion resistance. Continue to add pipe sections through the flashing until the height of the vent cap meets the minimum height requirements specified in table below or local codes. Note that for steep roof pitches, the vertical height must be increased. A poor draft, or down drafting can result from high wind conditions near big trees or adjoining roof lines, in these cases, increasing the vent height may solve the problem.

Roof Pitch	Minimum Vent Height	
	Feet	Meters
flat to 7/12	2	0.61
over 7/12 to 8/12	2	0.61
over 8/12 to 9/12	2	0.61
over 9/12 to 10/12	2.5	0.76
over 10/12 to 11/12	3.25	0.99
over 11/12 to 12/12	4	1.22
over 12/12 to 14/12	5	1.52
over 14/12 to 16/12	6	1.83
over 16/12 to 18/12	7	2.13
over 18/12 to 20/12	7.5	2.29
over 20/12 to 21/12	8	2.44

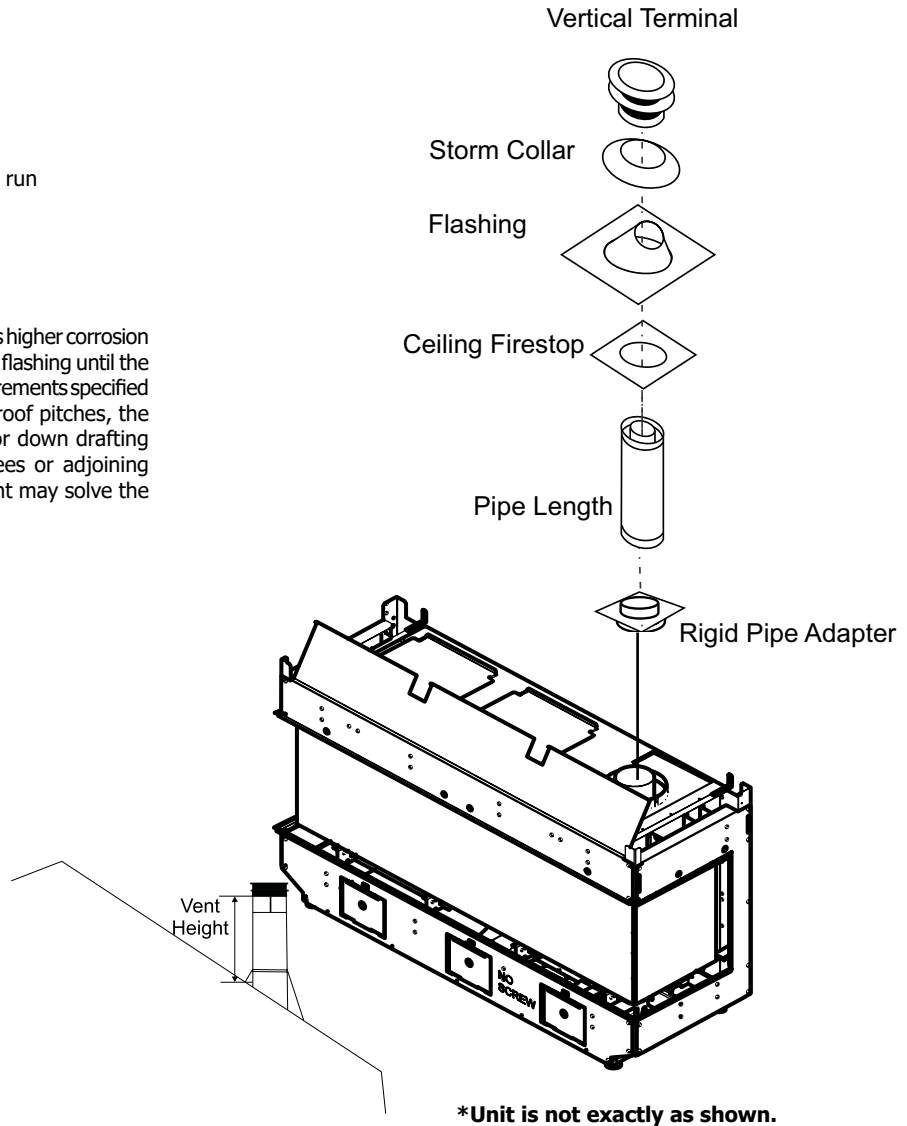

WARNING:

Do not combine venting components from different venting systems.

However use of the the AstroCap™ and FPI Riser is acceptable with all systems.

This product has been evaluated by Intertek for using a Rigid Pipe Adaptor in conjunction with Duravent Direct-Vent, Selkirk Direct-Temp, Ameri Vent Direct Venting, ICC Excel Direct, Olympia Ventis DV, and Security Secure Vent systems. Use of these systems with the Rigid Pipe adaptor is deemed acceptable and does not affect the Intertek WHI listing of components.

When using Rigid Vent other than Simpson Dura-Vent, 3 screws must be used to secure rigid pipe to adaptor.

The FPI AstroCap™ and FPI Riser Vent terminal are certified for installations using FPI venting systems as well as Simpson Dura-Vent® Direct Vent, American Metal Products Ameri Vent Direct Vent, Security Secure Vent®, ICC Excel, Olympia Ventis DV, Selkirk Direct-Temp. AstroCap™ is a proprietary trademark of FPI Fireplace Products International Ltd. Dura-Vent® and Direct Vent are registered and/or proprietary trademarks of Simpson Dura-Vent Co. Inc.

Venting Arrangement for Vertical Terminations - 5" x 8" (127 mm x 203 mm) Rigid and Flex Pipe (Non Power Vent)

The shaded area in the diagram shows all allowable combinations of straight vertical and offset-to-vertical terminations, using two 90° elbows with rigid/flex pipe venting systems.

- Two 45° elbows equal to one 90° elbow.
- Vent must be supported at offsets.
- Minimum distance between elbows is 1 ft. (305 mm).
- Maintain clearances to combustibles as listed in the "Clearances" section.
- Horizontal vent must be supported every 3 feet (0.9 m).
- Firestops are required at each floor level and whenever passing through a wall.
- Must use optional rigid pipe adaptor (Part# 770-994) when using rigid pipe vent systems.
- Refer to the "Vent Restrictor Position" section for details on how to change the vent restrictor from the factory setting of Set 0 through to Set 5, if required.

For vertical terminations, the Regency Direct Vent Flex System may be used for installations with a maximum vent length of up to 40 feet including offsets. If longer runs are required, rigid pipe must be used. If no offsets are used, the maximum run is per the chart on this page.

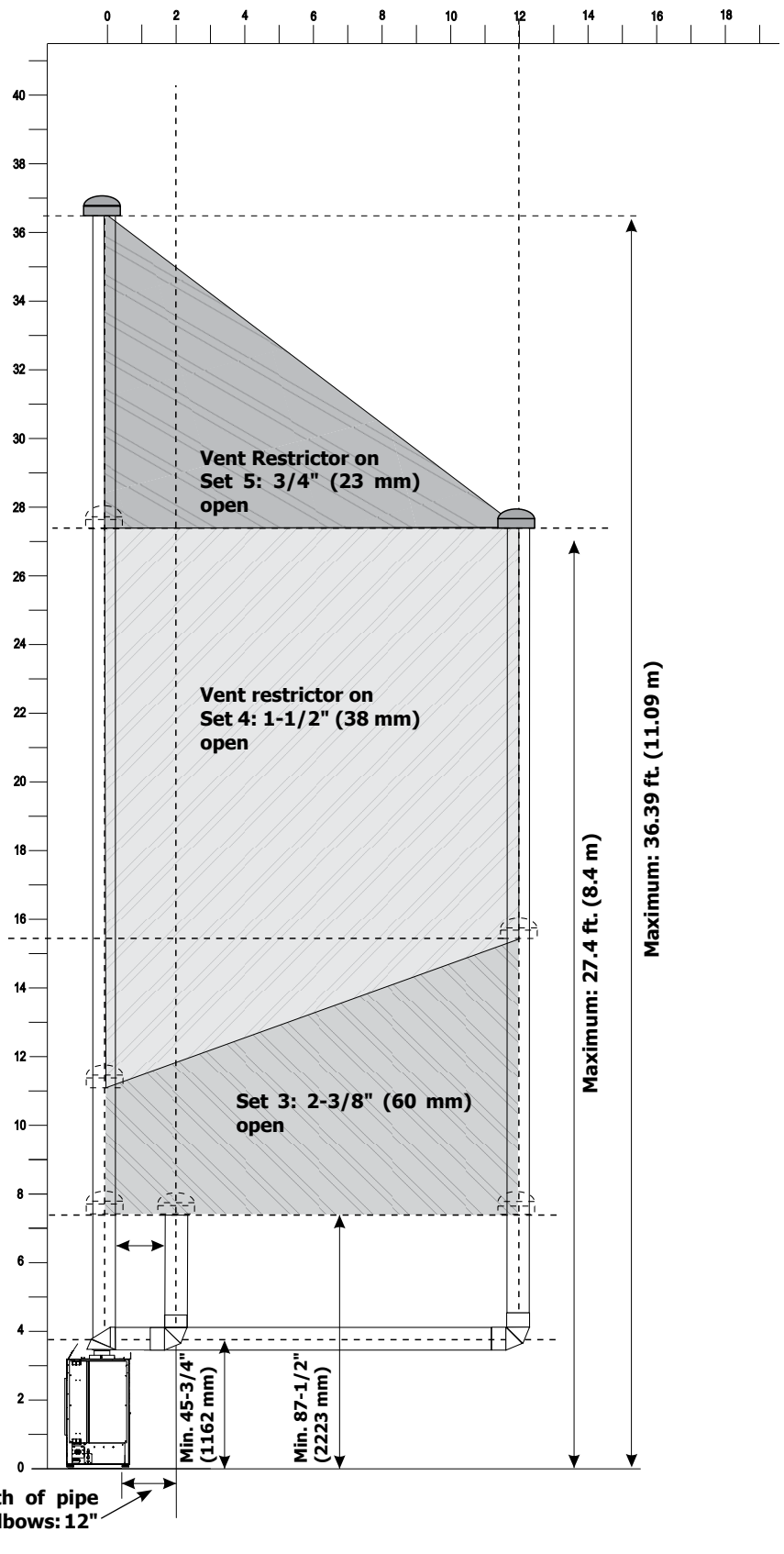

Vertical Terminations - Rigid/Flex Pipe 5" x 8" (Non Power Vent)

- Two 45° elbows equal to one 90° elbow. Maximum of six 45° elbows allowed.
- Vent must be supported at offsets.
- Minimum distance between elbows is 1 ft. (305mm).
- Maintain clearances to combustibles as listed in the "Clearances" section.
- Horizontal vent must be supported every 3 feet.
- Firestops are required at each floor level and whenever passing through a wall.
- Must use optional rigid pipe adaptor (Part# 770-994 when using rigid pipe vent systems)

Vertical Venting with Three (3) 90° Elbows

One 90° elbow = Two 45° elbows.

Option	V	H + H1	V + V1	
A)	1' Min.	2' Max	3' Min.	With these options, max. total pipe length is 30 feet with min. of 10 feet total vertical and max. 8 feet total horizontal. Please note min. 1 foot between 90° elbows is required.
B)	2' Min.	3' Max	4' Min.	
C)	3' Min.	4' Max	6' Min.	
D)	4' Min.	5' Max	7' Min.	
E)	5' Min.	6' Max	8' Min.	
F)	6' Min.	7' Max	9' Min.	
G)	7' Min.	8' Max	10' Min.	
Lengths do not include elbow indicated Restrictor Set 0 - Factory Setting				

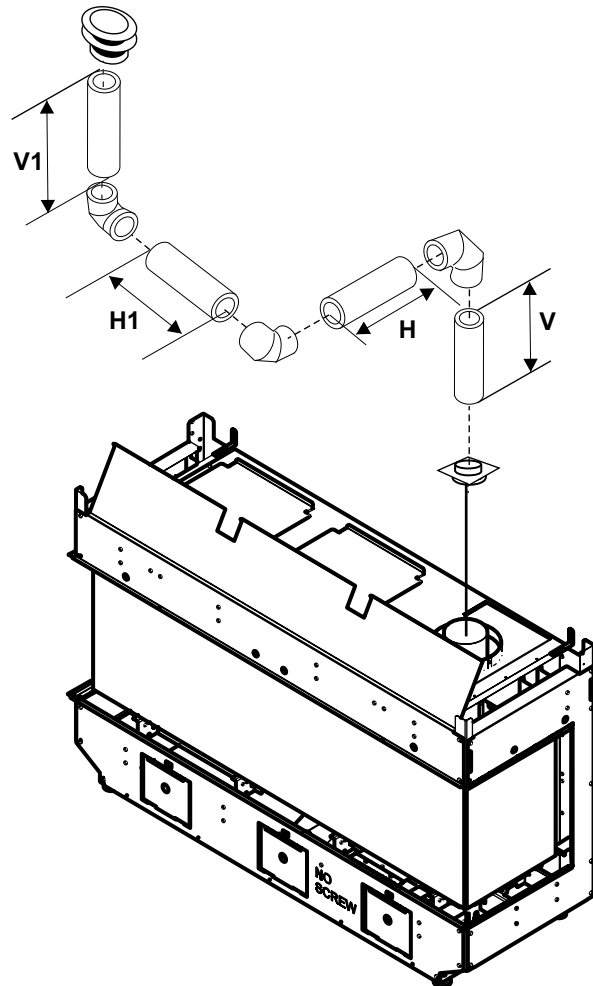

Vertical Terminations - Vertical Flex Vent Kit (Part #946-772) (Non Power Vent)

Vertical Flex Vent Kit includes:

- 20 ft. flex pipe (inner & outer) with 10 spacers
- 3 wall straps
- Ceiling firestop
- Firestop spacer
- Brackets
- Flex to rigid adaptor
- Roof support
- 36" rigid DuraVent pipe
- Storm collar
- High wind termination cap
- Hardware

NOTE The roof flashing is not included with this kit and must be purchased separately.

NOTE Vertical flex installations must conform to the limitations set in the vertical venting charts.

You must choose 1 of the following:

Part #	Description
58DVA-F6-0/12-6/12	Roof Flashing
58DVA-F12-7/12-12/12	Roof Flashing

- Maintain the 1-1/2" (38 mm) clearance (air space) to combustibles when passing through ceilings, walls, floors, enclosures, attic rafters or other nearby combustibles. Do not pack air spaces with insulation. Check venting sections for the maximum vertical rise of the venting system and the maximum horizontal offset limitations.

Ensure that you maintain clearances around enclosures, walls, below or above floors, floor joists, etc. Each appliance has different clearance requirements (top,sides,bottom). See specific appliance manual for details.

- Set the appliance in its desired position. Drop a plumb bob down from the ceiling/floor joist to the position of the appliance flue exit and mark the location where the vent will penetrate the ceiling. Drill a small hole at this point. Next drop a plumb bob from the roof to the hole previously drilled at the ceiling level and mark the spot where the vent will penetrate the roof.
- Cut a hole in the roof centered on the small hole placed in the roof in the previous steps. The hole should be a minimum of 11" (279 mm). The hole may be round and or square.
- Slip the flashing under the shingles and line up flashing so it is centered to the hole (shingles should overlap half of the flashing) as per Diagram 1.

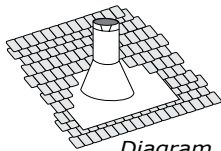

Diagram 1 - The upper half of the flashing is installed under the roofing material and not nailed down until the chimney is installed. This allows for small adjustments.

- A ceiling firestop/firestop spacer must be installed when passing through each floor or ceiling level. To install the ceiling firestop/firestop spacer in a flat ceiling or floor joist cut a 11" (279 mm) square hole. Frame the hole as show in Diagram 2 and install the ceiling firestop. Slide the top attic insulation spacer onto the top of the attic insulation shield/firestop - See Diagram 2a. Secure with 4 screws/nails. If more than one is required, these can be purchased separately.

NOTE The ceiling firestop/firestop spacer may be cut down to size if this shield is too high for the application.

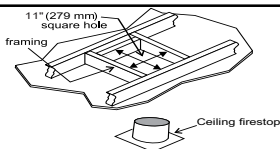

Diagram 2

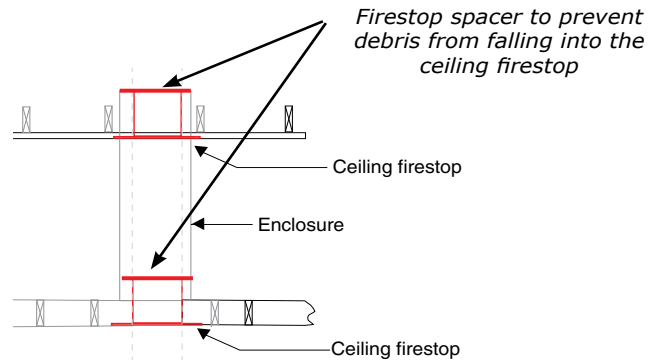

Diagram 2a

- Determine the overall height of the chimney from the top of the appliance to the underside of the vent. If required cut the flexible inner and outer pipe to the desired length up to a maximum of 20 ft. (6.1 m).
 - Put a bead of Mill-Pac around the 5" (127 mm) collar on the appliance and slide the inner flex pipe over the inner collar of the appliance and secure with a minimum of 3 screws.
 - Install 5" (127 mm) spacers around 5" (127 mm) flex.
 - Repeat Step 7 to install the outer pipe to the outer collar of the appliance.
- NOTE** If an offset is necessary in the attic or floor joists it is important to support the vent pipe every 3 feet (914 mm) to avoid excessive stress and sagging of the vent pipe. Wall straps are provided (3 in total) for this purpose. All round/plumbers strapping may also be used if further supports are required.
- Attach the rigid pipe section to the adaptor by using MillPac on the inner/ outer pipe. Use 3 screws to secure outer pipe.
 - Secure inner flex pipe to pipe adaptor using Mill-Pac over the adaptor. Slide the inner pipe over the flex to rigid adaptor and secure with 3 screws.
 - Repeat Step 11 to secure outer flex.

13. Slide the finished length up towards the flashing ensuring the length of pipe is a minimum of 2 feet (0.61 m) measured from the top of the roof. Level the chimney and secure using the roof support provided with kit to bottom side of the roof as shown using a minimum of 2 screws per side- see Diagram 3b. See Diagram 4 for roof pitch and height requirements. See Diagram 3a for securing method if 2 feet (0.61 m) is insufficient and additional lengths are required, this may be purchased separately. See Simpson Duravent components list in the instruction manual for part numbers.

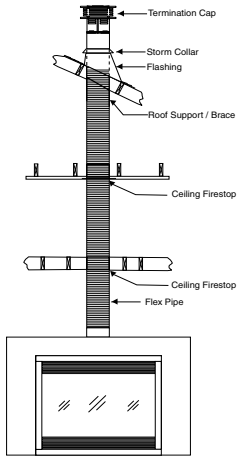
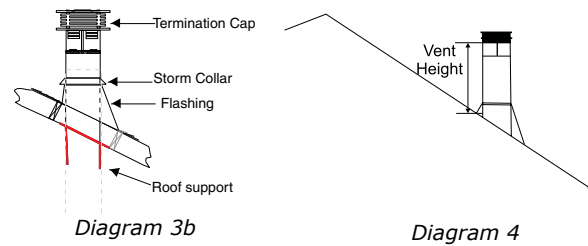

Diagram 3

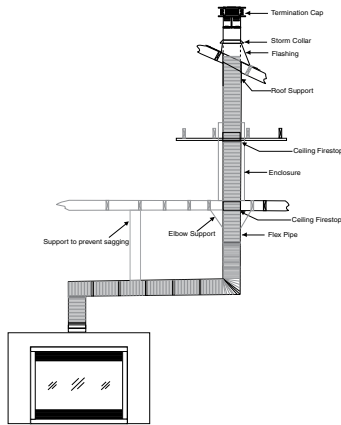

Diagram 3a

Roof Pitch	Minimum Vent Height	Minimum Vent Height
	Feet	Meters
flat to 7/12	2	0.61
over 7/12 to 8/12	2	0.61
over 8/12 to 9/12	2	0.61
over 9/12 to 10/12	2.5	0.76
over 10/12 to 11/12	3.25	0.99
over 11/12 to 12/12	4	1.22
over 12/12 to 14/12	5	1.52
over 14/12 to 16/12	6	1.83
over 16/12 to 18/12	7	2.13
over 18/12 to 20/12	7.5	2.29
over 20/12 to 21/12	8	2.44

14. Put a bead of caulking on the exterior between the outer pipe and flashing to prevent water from penetrating the chimney system.
15. Slide storm collar over pipe length until it reaches the flashing.
16. Install termination cap by twist locking it.
17. Secure the flashing to the roof using screws

Note: Any closets or storage spaces which the vent passes through must be enclosed.

Vertical Flex Extension Kit (Part # 946-769) (Non Power Vent)

20 foot (6.1 m) flex pipe extension

Vertical Flex Extension Kit includes:

- 20 ft. flex pipe (inner & outer) with 10 spacers
- 3 wall straps
- Flex adaptor
- Hardware

Used in conjunction with the 946-772 Vertical Flex Vent Kit for vertical installations.

1. Stretch out both inner 5" (127 mm) and outer 8" (203 mm) pipe up to a maximum of 20 ft. (6.1 m).

NOTE The inner and outer pipes may be cut if only a short length is required.

2. Install spring spacers around 5" (127 mm) inner pipe as shown. Slide outer flex pipe over and all the way down the 5" (127 mm) pipe.
3. Apply a bead of Mill Pac around the perimeter of the 5" (127 mm) inner collar of the flex adapter and slip the 5" (127 mm) inner flex pipe from the Vertical termination kit over the flex adapter ensuring that the inner flex pipe overlaps the collar by at least 1.4" (35 mm). Fasten with 3 screws.
4. Apply a bead of Mill Pac around the perimeter of the 8" (203 mm) outer collar of the flue adapter and slip it over the 8" (203 mm) outer flex pipe from the vertical termination kit ensuring that the outer flex pipe overlaps the collar by at least 1.4" (35 mm). Fasten with the 3 screws.
5. Repeat steps to secure the other end of the flex adapter using the flex kit.
6. See Vertical Vent installation instructions for installation of the complete vent system.

NOTE If an offset is necessary in the attic or floor joists it is important to support the vent pipe every 3 ft. (0.91 m) to avoid excessive stress and sagging of the vent pipe. Wall straps are provided (3 in total) for this purpose.

All round/plumbers strapping may also be used if further supports are required.



Ceiling Firestop / Firestop Spacer (Part # 946-770) (Non Power Vent)

Used in conjunction with the 946-772 Vertical Flex Kit and 946-769 Vertical Flex Extension Kit.

A ceiling firestop/firestop spacer must be installed when passing through each floor or ceiling level.

Steps to install the ceiling firestop/firestop spacer in a flat ceiling or floor joist:

1. Cut a 11" (279 mm) square hole.
2. Frame the hole as show in Diagram 1.
3. Install the ceiling firestop.
4. Slide the top attic insulation spacer onto the top of the attic insulation shield/firestop - See Diagram 1a.
5. Secure with 4 screws/nails.

Firestops can be purchased separately if more than one is required.

NOTE The ceiling firestop/firestop spacer may be cut down to size if it is too high for the application.

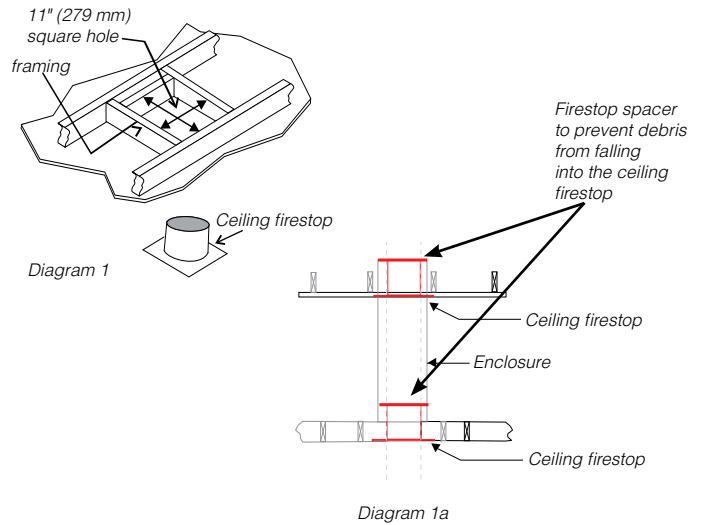

Exterior Vent Termination Locations (Power Vent)

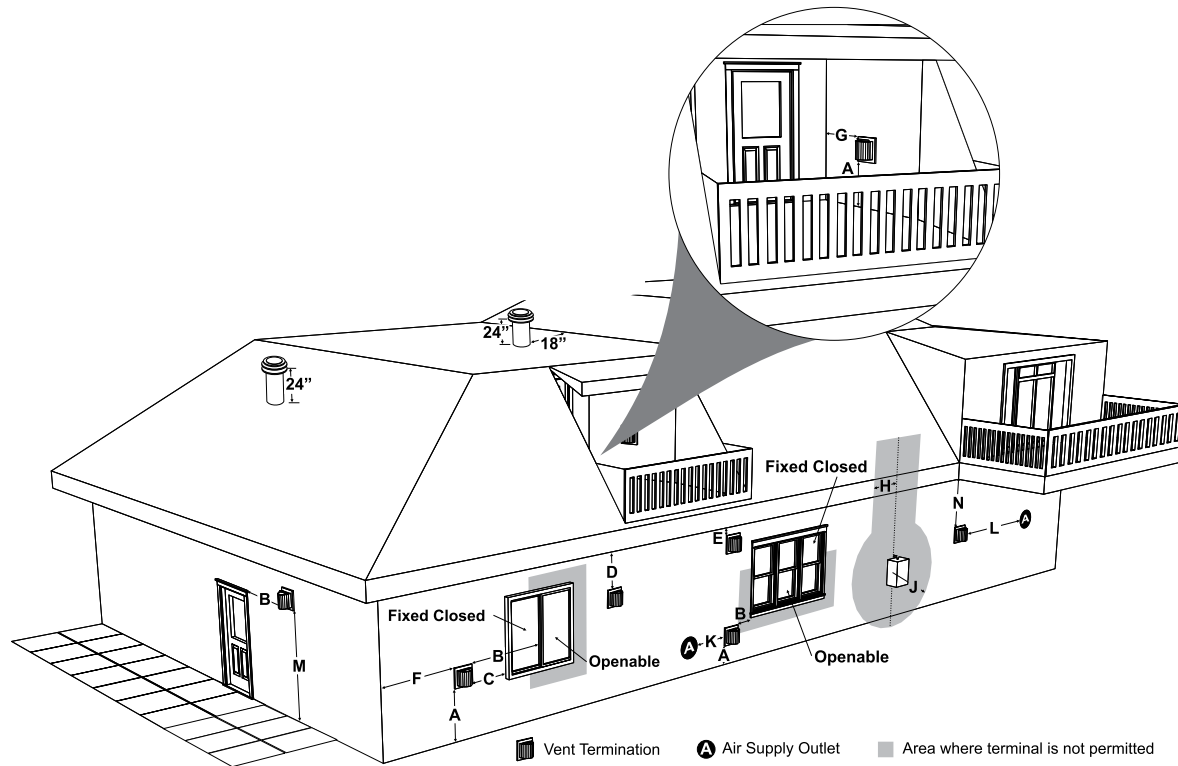

	Minimum Clearance Requirements	Canada ¹	USA ²
A	Clearance above grade, veranda, porch, deck, or balcony	12"(30cm)	12"(30cm)
B	Clearance to window or door that may be opened	12"(30cm)	9" (23cm)
C	Clearance to permanently closed window	*	*
D	Vertical clearance to ventilated soffit located above the terminal within a horizontal distance of 2 feet (61cm) from the center line of the terminal (check with the local code)	29"(74cm)	29"(74cm)
E	Clearance to unventilated soffit	29"(74cm)	29"(74cm)
F	Clearance to outside corner: with PowerVent Termination Cap (End of line) Clearance to outside corner: with AstroCap Termination Cap (Inline)	7"(18cm)	7"(18cm)
G	Clearance to inside corner: with PowerVent Termination Cap (End of line) Clearance to inside corner: with Astro Cap Termination Cap (Inline)	7"(18cm)	7"(18cm)
H	Clearance to each side of center line extended above meter/regulator assembly	36"(90cm) ^a	*
J	Clearance to service regulator vent outlet	36"(90cm)	*
K	Clearance to non-mechanical air supply inlet to building or the combustion air inlet to any other appliance	12"(30cm)	9" (23cm)
L	Clearance to a mechanical air supply inlet #3' (91cm) above if within 10' (3m) horizontally.	72"(1.8m)	36"(90cm) ^b
M	Clearance above paved sidewalk or a paved driveway located on public property	84"(2.1m) [†]	*
N	Clearance under veranda, porch, deck, or balcony	12"(30cm) [‡]	*

¹ In accordance with current CSA B149.1, *Natural Gas and Propane Installation Code*

² In accordance with the current ANSI Z223.1/NFPA 54, *National Fuel Gas Code*

[†] A vent shall not terminate directly above a sidewalk or paved driveway which is located between two single family dwellings and serves both dwellings

[‡] Permitted only if veranda, porch, deck, or balcony is fully open on a minimum of two sides beneath the floor

* Clearance in accordance with local installation codes and the requirements of the gas supplier

^a 3 feet (91cm) within a height of 15 feet (4.5m) above the meter / regulator assembly

^b 3 feet (91cm) above - if within 10 feet (3m) horizontally

4"x 6-5/8" Rigid Pipe Cross Reference Chart (Power Vent)

Components from different Manufacturers may not be mixed. Not All Rigid Pipe components are available directly from FPI.

IMPORTANT : When using the inline Power Vent system & rigid pipe:

Vertical Terminations (Inline): Only Simpson Duravent rigid pipe is approved for use. Must use the 46DVA-VCH vertical high wind cap as this is the only approved cap.

Horizontal Terminations (Inline): Only the 946-523/P Astro horizontal cap may be used in conjunction with any of the vent systems noted below.

Description	Simpson Direct Vent Pro®	Selkirk Direct Temp™	American Metal Products® Amerivent Direct	Metal-Fab™ Sure Seal	Security Secure-Vent®	ICC Excel Direct	Olympia Ventis DV*
High Wind Vertical Cap	46DVA-VCH	N/A	N/A	N/A	N/A	N/A	N/A
Flashing Flat Roof	46DVA-FF	N/A	N/A	N/A	N/A	N/A	N/A
Flashing 0/12-6/12	46DVA-F6	N/A	N/A	N/A	N/A	N/A	N/A
Flashing 7/12-12/12	46DVA-F12	N/A	N/A	N/A	N/A	N/A	N/A
Storm Collar	46DVA-SC	N/A	N/A	N/A	N/A	N/A	N/A
6" Pipe Length-Galvanized	46DVA-06	4DT-6	N/A	4D6	SV4L6	TC-4DL6	VDV-0406
6" Pipe Length-Black	46DVA-06B	4DT-6B	N/A	4D6B	SV4LB6	TC-4DL6B	VDVB-0406
7" Pipe Length-Galvanized	N/A	N/A	4D7	N/A	N/A	N/A	N/A
7" Pipe Length-Black	N/A	N/A	4D7B	N/A	N/A	N/A	N/A
9" Pipe Length-Galvanized	46DVA-09	4DT-9	N/A	N/A	N/A	TC-4DL9	VDV-0409
9" Pipe Length-Black	46DVA-09B	4DT-9B	N/A	N/A	N/A	TC-4DL9B	VDVB-0409
12" Pipe Length-Galvanized	46DVA-12	4DT-12	4D12	4D12	SV4L12	TC-4DL1	VDV-0412
12" Pipe Length-Black	46DVA-12B	4DT-12B	4D12B	4D12B	SV4LB12	TC-4DL1B	VDVB-0412
18" Pipe Length-Galvanized	46DVA-18	4DT-18	4D18	4D18	SV4LA	TC-4DL18	VDV-0418
18" Pipe Length-Black	46DVA-18B	4DT-18B	4D18B	4D18B	SV4LA	TC-4DL18B	VDVB-0418
24" Pipe Length-Galvanized	46DVA-24	4DT-24	4D24	4D24	SV4L24	TC-4DL2	VDV-0424
24" Pipe Length-Black	46DVA-24B	4DT-24B	4D24B	4D24B	SV4LB24	TC-4DL2B	VDVB-0424
36" Pipe Length-Galvanized	46DVA-36	4DT-36	4D36	4D36	SV4L36	TC-4DL3	VDV-0436
36" Pipe Length-Black	46DVA-36B	4DT-36B	4D36B	4D36B	SV4LB36	TC-4DL3B	VDVCB-0436
48" Pipe Length-Galvanized	46DVA-48	4DT-48	4D48	4D48	SV4L48	TC-4DL4	VDV-0448
48" Pipe Length-Black	46DVA-48B	4DT-48B	4D48B	4D48B	SV4LB48	TC-4DL4B	VDVB-0448
60" Pipe Length-Galvanized	46DVA-60	4DT-60	N/A	N/A	N/A	N/A	N/A
60" Pipe Length-Black	46DVA-60B	4DT-60B	N/A	N/A	N/A	N/A	N/A
Adjustable Length 3"-10"-Galvanized	N/A	N/A	N/A	4DAL	N/A	TC-4DLT	N/A
Adjustable Length 3"-10"-Black	N/A	N/A	N/A	4DALB	N/A	TC-4DLTB	N/A
Adjustable Length 7"-Galvanized	N/A	N/A	4D7A	N/A	N/A	N/A	N/A
Adjustable Length 7"-Black	N/A	N/A	4D7AB	N/A	N/A	N/A	N/A
Extension Pipe 8-1/2"-Galvanized	46DVA-08A	N/A	N/A	N/A	N/A	N/A	N/A
Extension Pipe 8-1/2"-Black	46DVA-08AB	N/A	N/A	N/A	N/A	N/A	N/A
Adjustable Length 12"-Galvanized	N/A	N/A	4D12A	N/A	SV4LA12	TC-4dLSI	N/A
Adjustable Length 12"-Black	N/A	N/A	4D12A	N/A	SV4LBA12	TC-4dLSIB	N/A
Extension Pipe 16"-Galvanized	46DVA-16A	N/A	N/A	N/A	N/A	N/A	N/A
Extension Pipe 16"-Black	46DVA-16AB	N/A	N/A	N/A	N/A	N/A	N/A
45° Elbow-Galvanized	46DVA-E45	4DT-EL45	4D45L	N/A	N/A	TE-4DE45	VDV-EL0445
45° Elbow-Black	46DVA-E45B	4DT-EL45B	4DT-EL45B	N/A	N/A	TE-4DE45B	VDVB-EL0445
45° Elbow Swivel-Galvanized	See 46DVA-E45	N/A	N/A	4D45L	SV4E45	N/A	N/A
45° Elbow Swivel-Black	See 46DVA-E45B	N/A	N/A	4D45LB	SV4EB45	N/A	N/A
90° Elbow-Galvanized	46DVA-E90	4DT-EL90S	4DT-EL90S	N/A	N/A	TE-4DE90	VDV-EL0445
90° Elbow-Black	46DVA-E90B	4DT-EL90SB	4DT-EL90SB	N/A	SV4EBR90-1	TE-4DE90B	VDVB-EL0445
90° Elbow, Swivel-Galvanized	See 46DVA-E90	N/A	N/A	4D90L	SV4E90-1	N/A	N/A
90° Elbow, Swivel-Black	See 46DVA-E90B	N/A	N/A	4D90LB	SV4EB90-1	N/A	N/A
90° Starter Elbow, Swivel-Galvanized	N/A	N/A	N/A	4D90A	N/A	N/A	N/A
Adaptor*	N/A	N/A	N/A	4D90L	N/A	N/A	VDV-UAA04
Ceiling Support	N/A	4DT-CS	4DSP	4DFSP	SV4SD	TM4-RDS	VDV-SCR04
Cathedral Support Box	46DVA-CS	4DT-CSS	4DRSB	4DRS	SV4CSB	TM4-SDS	VDV-CSS04
Wall Support/Band	46DVA-WS	4DT-WS/B	4DWS	4DWS	SV4BM	TM-SWS	VDV-WS04

4"x 6-5/8" Rigid Pipe Cross Reference Chart (Power Vent)

Description	Simpson Direct Vent Pro®	Selkirk Direct Temp™	American Metal Products® Amerivent Direct	Metal-Fab™ Sure Seal	Security Secure-Vent®	ICC Excel Direct	Olympia Ventis DV*
Offset Support	46DVA-ES	4DT-OS	N/A	N/A	SV4SU	TM-SOS	N/A
Wall Thimble-Black	46DVA-WT	4DT-WT	4DWT	4DWT	SV4RSM	N/A	VDV-WPT04
Wall Thimble Support/Ceiling Support	46DVA-DC	N/A	N/A	N/A	SV4PF	N/A	N/A
Firestop Spacer	46DVA-FS	4DT-FS	4DFSP	4DFS	SV4BF	TM-4CS	VDV-FS04
Trim Plate-Black	N/A	4DT-TP	4DFPB	4DcP	SV4LA	TM-4TP	VDV-WTC04
Attic Insulation Shield 12"	46DVA-IS N/A@ FPI	N/A	4DAIS12	DDIS	SV4RSA	N/A	VDV-AIS04
Attic Insulation Shield - Cold Climates 36"	N/A	N/A	4DAIS12	N/A	N/A	TM-4AS	N/A
Wall Firestop	46DVA-WFS	N/A	N/A	N/A	N/A	TM-4TR	VDV-FS04

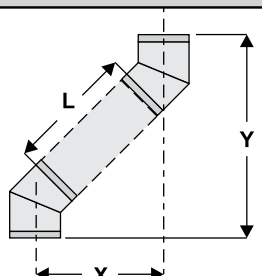
Offset Pipe Selection: Use this table to determine offset pipe lengths.				For specific instructions on venting components - visit the manufacturers website listed below. Simpson Direct Vent Pro: www.duraavent.com Selkirk Direct-Temp: www.selkirkcorp.com American Metal Products: www.americanmetalproducts.com Metal-Fab Sure Seal: www.mtfab.com Security Secure Vent: www.securitychimneys.com Industrial Chimney Company: www.icc-rsf.com Olympia Ventic DV: www.olympiachimney.com
Pipe Length (L)	4" x 6-5/8" Venting			
	Run (X)	Rise (Y)		
0" (0mm)	4-7/8" (124mm)	13-7/8" (340mm)		
6" (152mm)	8" (203mm)	16-1/2" (419mm)		
9" (229mm)	10-1/8" (257mm)	18-5/8" (473mm)		
12" (305mm)	12-1/4" (311mm)	20-3/4" (527mm)		
24" (610mm)	20-5/8" (524mm)	29-1/8" (740mm)		
36" (914mm)	29" (737mm)	37-1/2" (953mm)		
48" (1219mm)	37-7/16" (951mm)	45-15/16" (1167mm)		

Introduction

IMPORTANT

- The instructions contained in this manual must be read carefully prior to installation of this appliance.
- 120 Volt AC power is required for this appliance to operate. A receptacle box, receptacle, and cover are provided. See the "Wiring the Unit" section in this manual. Electrical power must be brought to the appliance by a licensed electrician.

The City 50 Series power vent system is designed to allow the installation of this gas appliance when typical vent configurations (Non-Power Vent Direct Vent Systems With no Fan Assist) are not possible due to excessive offsets, long or negative vent runs, etc.

When installed as a power vent appliance, this unit is designed to use flex or rigid venting.

NOTES

The City 50 models come with a 5" inner and 8" outer collar which must be reduced to 4" inner x 6-5/8" outer (102 mm x 168 mm) in all applications. See required reducers required as per below depending if using rigid/flex pipe.

The Vent Pipe Adaptor must always be used for Power Vent System: See below " Pipe Adaptor & Reducer CHART".

Vent Pipe Adaptor & Reducer Chart

	Ridge Pipe Adaptor	Flex Pipe Reducer
City 50, 60 & 72 Series	5" x 8" Adaptor (770 - 994)	4" x 6 5/8" Reducer (946 - 758)
	4" x 6 5/8" Collar Reducer (946 - 606)	

NOTES



- Rigid pipe is approved for up to 72 feet (21.95 m).
- Flex pipe is approved for up to 40 feet (12.19 m) using 2 X 946-756-- 20 foot (6.10 m) flex kits.

There are two options available when installing this unit as a power vent appliance:

- End of line flush horizontal power vent system (Part #946-535): flush power vent fan acts as the termination cap and sits flush to the outside wall. Allowed for horizontal termination only.
- Inline power vent system (Part #666-945): power vent fan terminal is incorporated into the vent run - allows for both horizontal and vertical termination.

This unit may be terminated vertically or horizontally using the Power Vent Systems available. See the following pages for various vent configurations using rigid or flex & vertical or horizontal terminations. The instructions contained in this manual must be read carefully prior to installation.

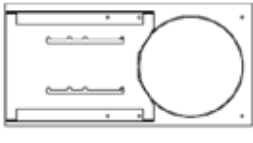
Vent Restrictor Position

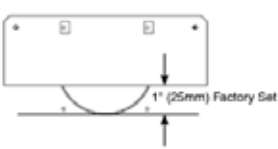
	City 50 Series, City 60 Series City 72 Series	City 40 Series	
In_Line	Full open	Full open	
End_Line	Full open	1" Open	
Restrictor Position			

Note: For specific installation instructions for both In line and End of line, see power vent system instruction manual which may be found in the QR code located below. The following pages in this manual will only detail allowable vent configurations for both inline and end of line vent power vent systems. Part # of the Power Vent System manual is 920-544.



Power Vent System
Manual

Minimum Vent Clearances to Combustibles

Horizontal Top	3" (76mm)
Horizontal Side	2" (51mm)
Horizontal Bottom	2" (51mm)
Vertical Vent	2" (51mm)

Vent Chart for Power Vent Only

Horizontal Terminations - Inline Horizontal Vent Chart Rigid/Flex

This section is for the Power Vent System installation. For a detailed installation information, refer Power Vent System installation instructions that comes with the Power Vent Kit. When you install the Power vented fireplace, you need one of the following Power Vent System Kit depending your venting layout. For the complete Power Vent installation, refer the Power Vent System installation instruction in Power vent system Kit.

In line Power Vent Kit # 666-945

RIGID PIPE: MUST USE RIGID PIPE ADAPTOR 770-994 AND 946-606 PIPE REDUCER TO 4" X 6 5/8" (102 mm x 168 mm).
 FLEX VENT: MUST USE REDUCER 946-758 TO 4" X 6 5/8" (102 mm x 168 mm).

- NOTES**
- Rigid pipe is approved for up to 72 feet (22 m).
 - Flex pipe is approved for up to 40 feet (12.2 m) using two 20 foot (6.1 m) flex kits (part # 946-756).
 - This model comes with a 5" (127 mm) inner and an 8" (203 mm) outer collar which must be reduced to 4" x 6-5/8" (102 mm x 168 mm) in all applications.
 - Must be terminated horizontally. Vertical terminations are not permitted.

The gas power vent system is designed to allow the installation of a gas appliance when typical vent configurations (shown in this manual) are not possible.

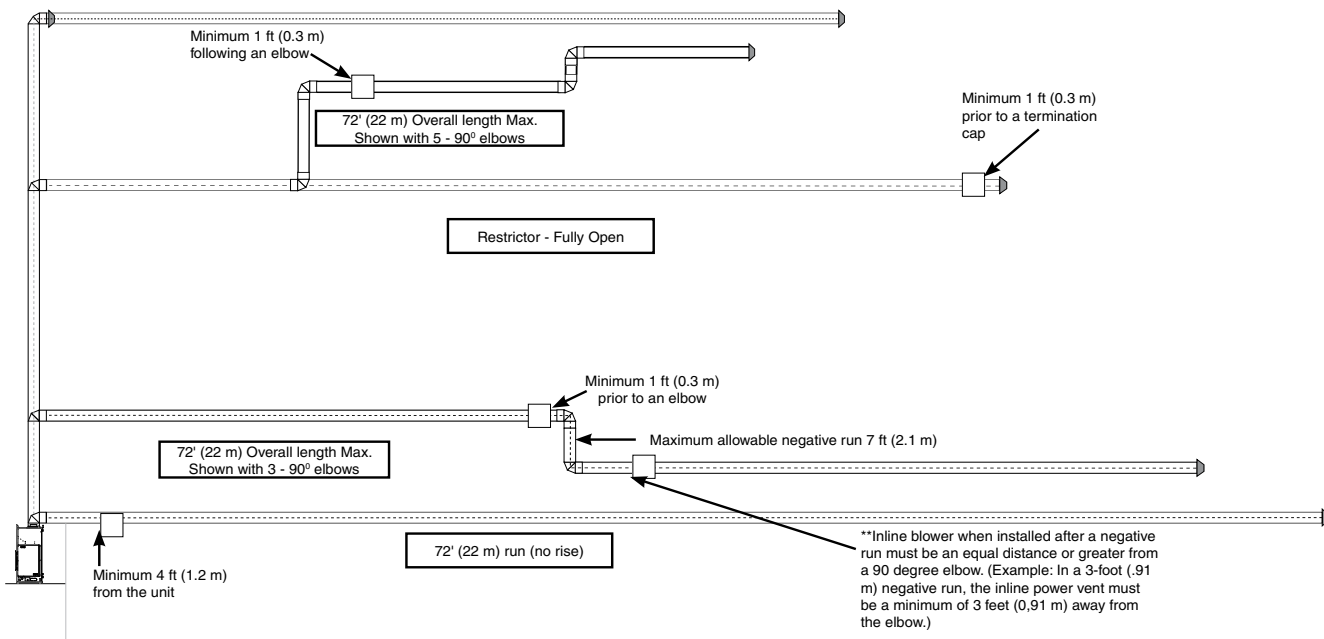

- IMPORTANT**
- **Maximum total vent length (based on overall length of combined chimney components) = 72' (22 m)**
 - **Maximum total negative vent length = 7' (2.1 m).**
 - **Do not run positive venting after a negative run.**
 - **Maximum of six - 90° elbows permitted.**
 - **One 90° elbow = two 45° elbows.**
 - **Minimum 4' (1.2 m) from the unit prior to terminating.**

Inline power vent location restrictions:
 Minimum 4 ft (1.2 m) from the unit
 Minimum 1 ft (0.3 m) prior to an elbow.
 Minimum 1 ft (0.3 m) following an elbow.
 Minimum 1 ft (0.3 m) prior to a termination cap.
 When the inline blower is installed after a negative run, for every foot of negative run the inline blower must be an equal distance or greater from the 90-degree elbow. See example above.

Vent Restrictor Position

No vent restrictor required.

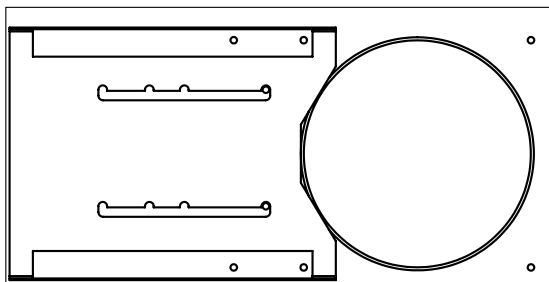

Set 0
 Fully open
 Factory Set

Vent Chart for Power Vent Only

Horizontal Terminations - End of Line Horizontal Vent Chart Rigid/Flex

For the complete Power Vent installation, refer the Power Vent System installation instruction in Power vent system Kit **End Line Power Vent Kit # 946-535**

RIGID PIPE: MUST USE RIGID PIPE ADAPTOR 770-994 AND 946-606 PIPE REDUCER TO 4" X 6 5/8" (102 mm x 168 mm).

FLEX VENT: MUST USE REDUCER 946-758 TO 4" X 6 5/8" (102 mm x 168 mm).

NOTES

- Rigid pipe is approved for up to 72 feet (22 m).
- Flex pipe is approved for up to 40 feet (12.2 m) using two 20 foot (6.1 m) flex kits (part # 946-756).
- This model comes with a 5" (127 mm) inner and an 8" (203 mm) outer collar which must be reduced to 4" x 6-5/8" (102 mm x 168 mm) in all applications.
- Must be terminated horizontally. Vertical terminations are not permitted.

The gas power vent system is designed to allow the installation of a gas appliance when typical vent configurations (shown in this manual) are not possible.

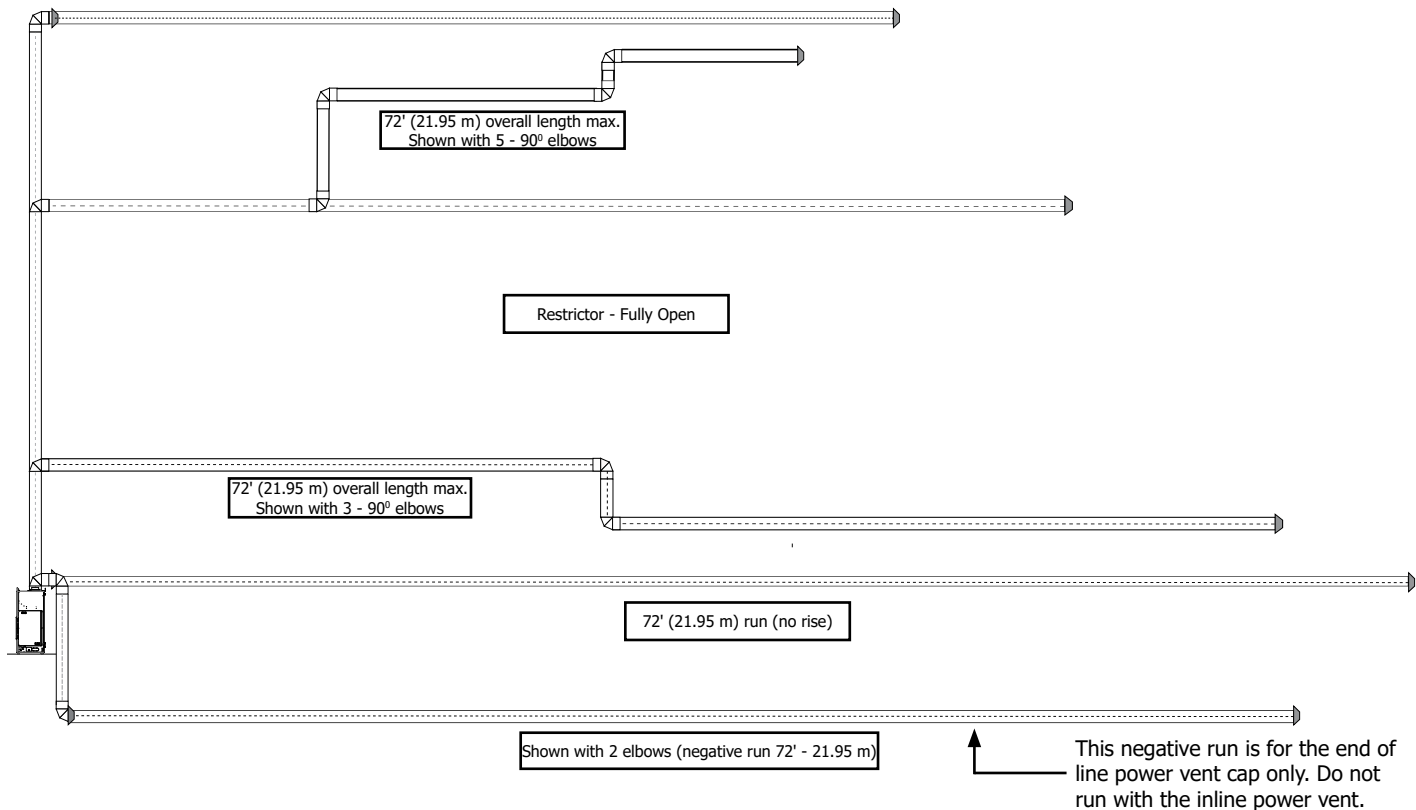

- #### IMPORTANT
- **Maximum total vent length (based on overall length of combined chimney components) = 72' (21.95 m)**
 - **Maximum total negative vent length = 7' (2.1 m).**
 - **Do not run positive venting after a negative run.**
 - **Maximum of six - 90° elbows permitted.**
 - **One 90° elbow = two 45° elbows.**
 - **Minimum 4' (1.2 m) from the unit prior to terminating.**

Vent Restrictor Position

No vent restrictor required.

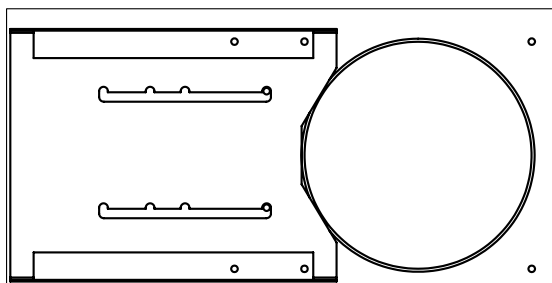

Set 0
Fully open
Factory Set

Venting Arrangement for Vertical Terminations

Inline Power Vent Rigid/Flex

In line Power Vent Kit # 666-945

Vertical venting with straight vertical venting and/or with a max. of six (6) 90° Elbows (1 - 90° = 2 - 45°)

- NOTES**
- Rigid pipe is approved for up to 72 feet (22 m).
 - Flex pipe is approved for up to 40 feet (12.2 m) using two 20 foot (6.1 m) flex kits (part # 946-756).

- Two 45° elbows equal to one 90° elbow.
- Vent must be supported at offsets.
- Minimum distance between elbows is 1 ft. (0.3 m).
- Maintain clearances to combustibles as listed in the "Clearances" section.
- Horizontal vent must be supported every 3 feet (0.91 m).
- Firestops are required at each floor level and whenever passing through a wall.

Restrictor set on 0 (fully open) regardless of vent run.

- Inline power vent location restrictions:**
- Minimum 4 ft (1.2 m) from the unit.
 - Minimum 1 ft (0.3 m) prior to an elbow.
 - Minimum 1 ft (0.3 m) following an elbow.
 - Minimum 2 ft (0.6 m) prior to a termination cap.
 - Minimum 2 ft. from inline PV to termination cap.
 - Minimum 4' from top of unit to inline PV.
 - Max. of 72' (22 m), using up to six 90° elbows
 - (Example shows two 90° elbows).
 - No negative runs.

- NOTE**
- The inline power vent must be installed within the confines of the home/structure.

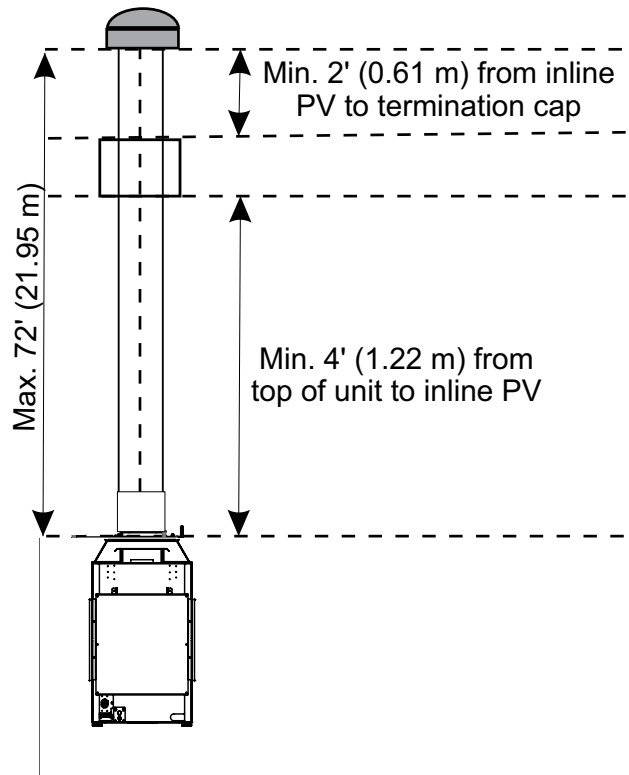

Max. of 72' (21.95 m), using up to six 90° elbows
(Note: two 90° elbows shown.)

