

HZ40E Gas Fireplace

Model	HZ40E-NG11	HZ40E-LP11
Fuel Type	Natural Gas	Propane
Minimum Supply Pressure	5" W.C. (1.25 kPa)	11" W.C. (2.73 kPa)
Manifold Pressure - High	3.5" W.C. (0.87 kPa)	10" W.C. (2.48 kPa)
Manifold Pressure - Low	1.6" W.C. (0.41 kPa)	6.4" W.C. (1.59 kPa)
Orifice Size -Altitude 0-4500 ft.	#40 DMS	#53 DMS
Minimum Input Altitude 0-4500 ft. (0-1372m)	18,000 BTU/h (5.28 kW)	21,000 BTU/h (6.15 kW)
Maximum Input Altitude 0-4500 ft. (0-1372m)	26,000 BTU/h (7.61 kW)	25,500 BTU/h (7.47 kW)
Vent Sizing - Flex / Rigid	4" Inner / 6-7/8" Outer	4" Inner / 6-7/8" Outer
CSA P.4.1	64.44%	66.75%

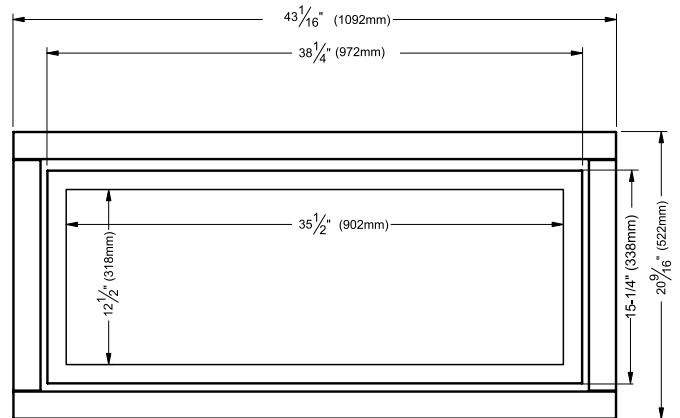

Approved Venting Systems	
Flex Vent Systems:	FPI AstroCap™ Flex Vent
Rigid Pipe Vent Systems:	Simpson Direct Vent Pro® Selkirk Direct-Temp™ Metal-Fab® Sure Seal ICC Excel

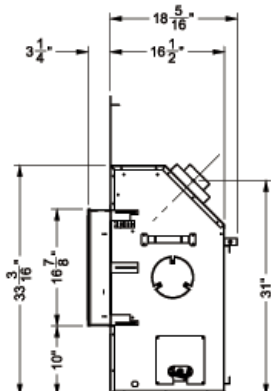
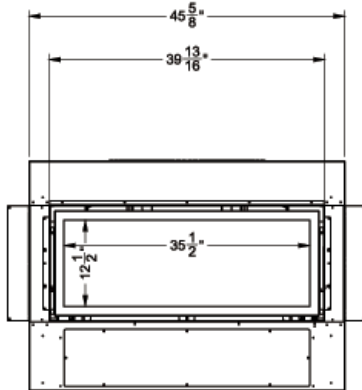
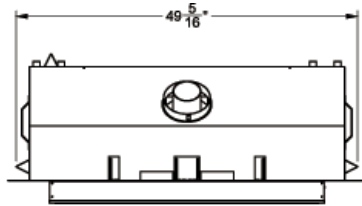

Inner and outer faceplate dimensions

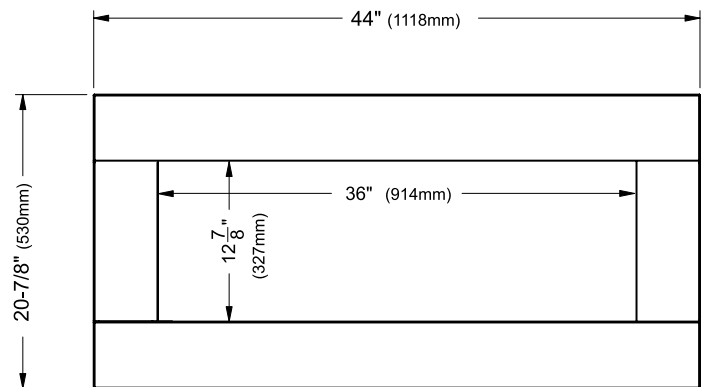

4 piece faceplate/Verona Surround dimensions

FRAMING DIMENSIONS

NOTE: If not purchasing the optional steel stud kit - adhere to the same framing if purchasing steel studs elsewhere. The use of the optional kit is highly recommended as it was designed specifically for the product to facilitate ease of installation.

Framing Dimensions	Description	HZ40E
A	Framing Height	42" (1067mm)
B	Framing Width	49-7/8" (1266mm)
C*	Framing Depth*	C1 Horizontal Vent 21-3/16" (538mm) C2 Vertical Vent 25-3/16" (640mm) Vertical rise -terminating horizontal
D	Minimum Height to Combustibles	43-7/8" (1114mm)
E	Corner Wall Depth	61" (1549mm)
F	Corner Facing Wall Width	86-1/4" (2191mm)
G	Vent Centerline Height	36 - 1/4" (921mm)
H	Non-combustible facing height	17" (432mm)
I	Gas Connection Opening Height	2" (51mm)
J	Gas Connection Height	4 - 3/16" (106mm)
K	Gas Connection Inset	8 - 5/16" (211mm)
L	Gas Connection Opening Width	3 - 1/2" (89mm)

* Framing depth measurement is noted with the nailing strips set as far forward on the firebox as possible. The nailing strips can be adjusted back up to 3-1/4" to allow for varying thicknesses in non-combustible material & wall finishes.

Note: All other framing around the perimeter may be of wood construction.

Note: Three horizontal steel studs must be installed after the unit is in position and the venting, gas, and electrical is installed. The horizontal studs allow the non-combustible wall board to be attached and supported.

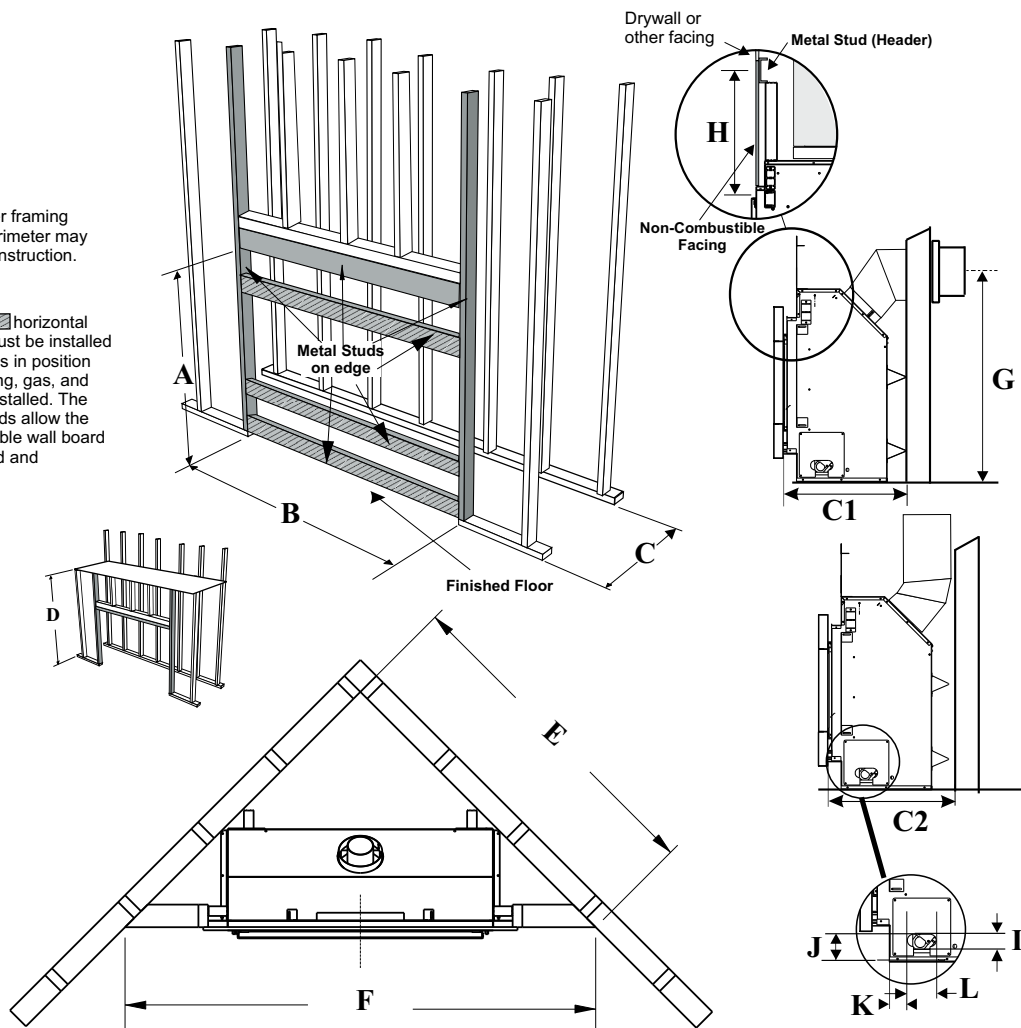

MANTEL CLEARANCES

Due to the extreme heat this fireplace emits, the mantel clearances are critical.
 Combustible mantel clearances from top of front facing are shown in the diagram on the right.

Note: Ensure the paint that is used on the mantel and the facing is "high quality" or the paint may discolour.

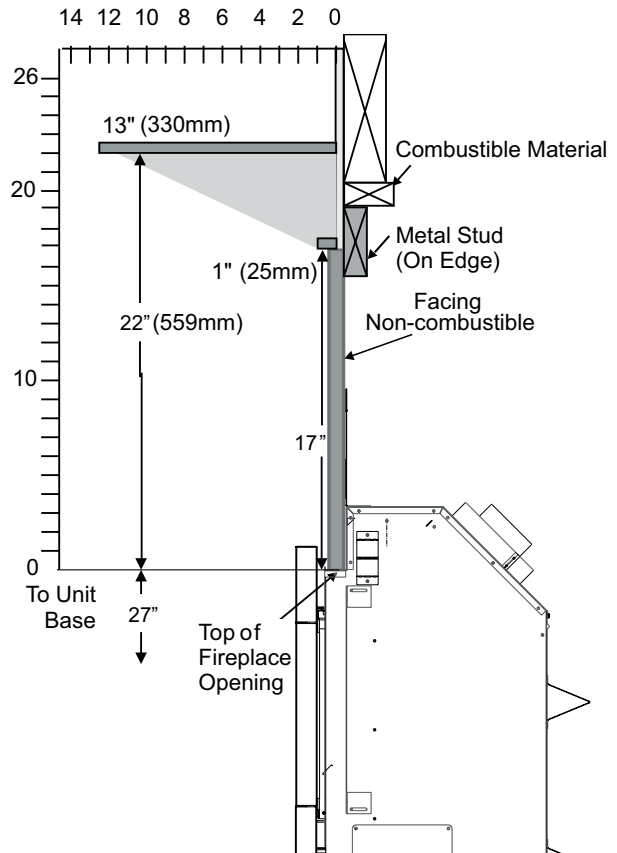

MANTEL LEG CLEARANCES

Combustible mantel leg clearances as per diagram:

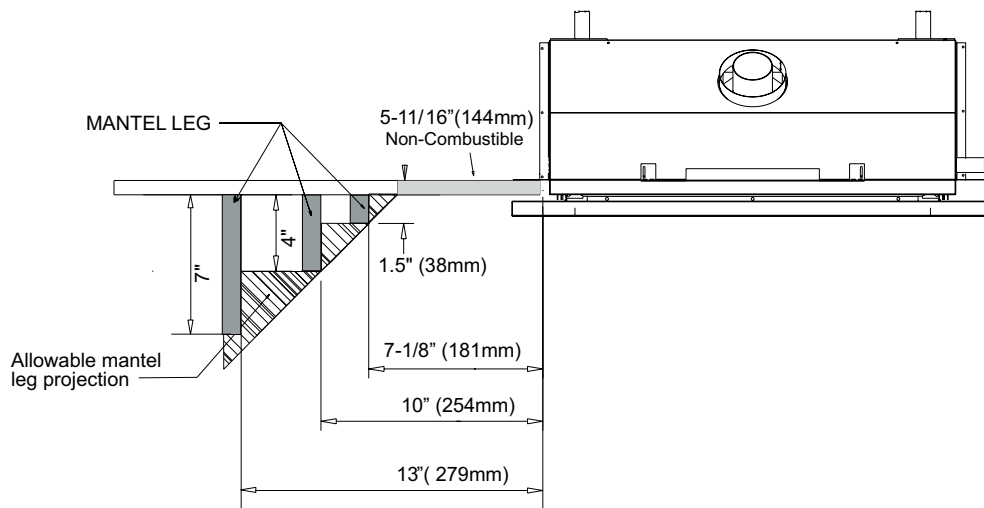

CLEARANCES

The clearances listed below are Minimum distances unless otherwise stated:

A major cause of chimney related fires is failure to maintain required clearances (air space) to combustible materials. It is of the greatest importance that this fireplace and vent system be installed only in accordance with these instructions.

Caution Requirements

The top, back and sides of the fireplace are defined by standoffs. The metal ends of the standoff may **NOT** be recessed into combustible construction.

WARNING

Fire hazard is an extreme risk if these clearances (air space) to combustible materials are not adhered to. It is of greatest importance that this fireplace and vent system be installed only in accordance with these instructions.

Clearance:	Dimension	Measured From:
A: Mantel Height (min.)	17" (330mm)	Top of Fireplace Opening
B: Sidewall (on one side)	8" (203mm)	Side of Fireplace Opening
C: Ceiling (room and/or alcove)	22" (559mm)	Top of Fireplace Opening
D: Mantel Depth (max.)	13" (330mm)	22" Above Fireplace Opening
E: Alcove Width	84" (2134mm)	Sidewall to Sidewall (Minimum)
F: Alcove Depth	36" (914mm)	Front to Back Wall (Maximum)
G: From Floor	27" (686mm)	Top of Fireplace Opening
Note:	0"	No hearth required



The **HeatWave** Duct Kit and the Heat Release Kit have different clearance and framing requirements, check the **HeatWave** and Heat Release manual for details.

Heat Release Kit

Flue Clearances to Combustibles	
Horizontal - Top	3"
Horizontal - Side	2"
Horizontal - Bottom	2"
Vertical	2"
Passing through wall/floor/ceiling - when firestop is used.	1-1/2"

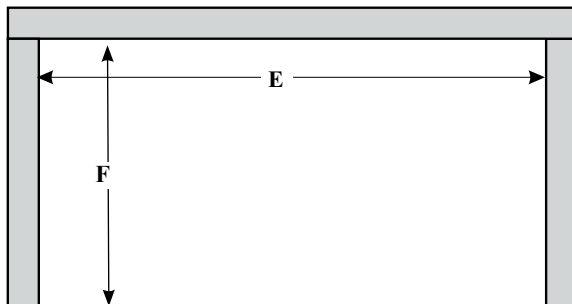
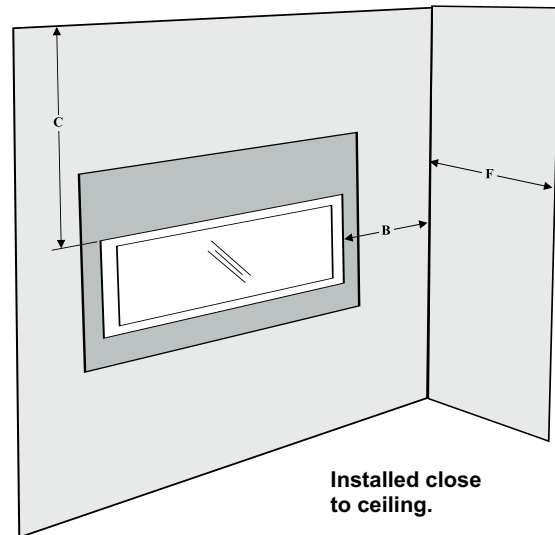
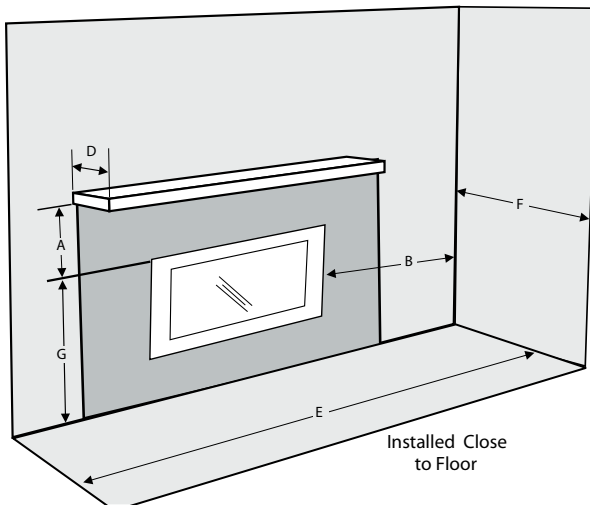

Alcove

NON-COMBUSTIBLE REQUIREMENTS

* Installation of the Receiver must be completed before installing non-combustible facing.

All three pieces (top, 2 sides) are supplied to meet the non combustibile requirements.

Calcium silicate board is a high - grade material with cement, quartz, natural and selected minerals as the main raw materials. It is widely used for partitions and ceilings in buildings. It is fire proof and earthquake proof.

If finishing the wall above the unit with materials such as tile, brick, marble, etc. non-combustible board available from the building supply store can be used.

Note: Calcium Silicate is 1/2" thick

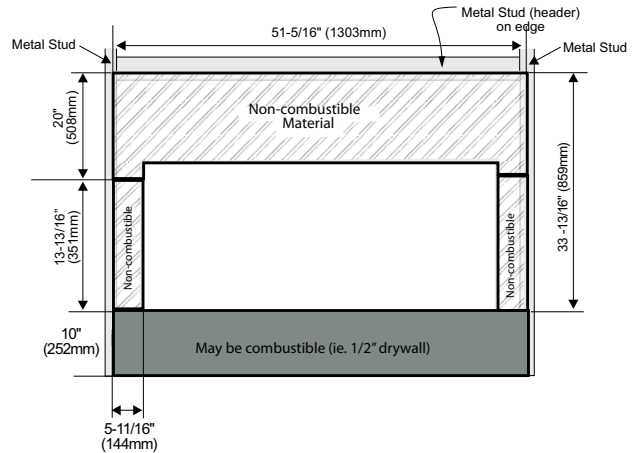

NON-COMBUSTIBLE FACING INSTALLATION

Caution: The non-combustible board supplied with this unit can be damaged if dropped or struck. **Handle with care.**

1. Using drywall screws - secure non combustibile material around unit, framing and top nailing strip every 6 inches.

Important Note: To avoid cracking the board - pre-drill holes prior to securing to unit/ framing.

2. Wipe any debris/dust from the non combustibile material and drywall.
3. Prior to securing it is mandatory to prime the facing and edges using a quality primer. This will ensure proper adhesion of both the tape and mud. The supplied board is very porous. Failure to follow this procedure will result in cracked seams.
4. Tape the seams using a mesh type tape.
5. Mud seams as normal. We recommend using a product called Durabond high strength compound - for the first coat. This product can be found at most hardware stores. Mud must be cured as per manufacturer's recommendations.
6. Prime wall for a second time for proper adhesion of paint
7. Paint walls using a high quality paint which will withstand the high temperatures being emitted from this appliance.

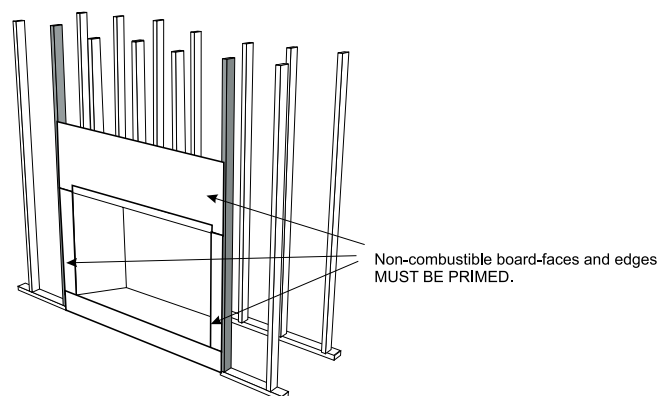
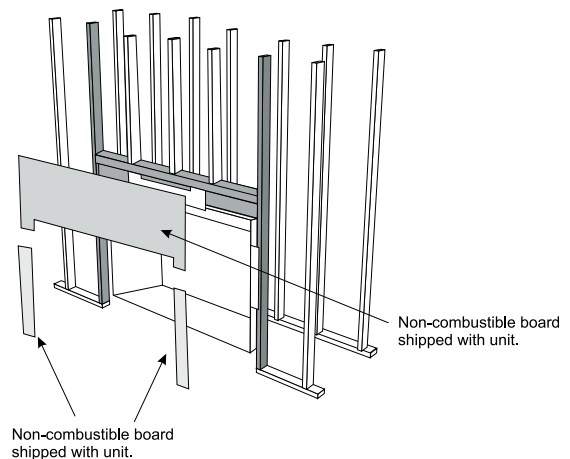

FRAMING & FINISHING

1. Frame in the enclosure for the unit with framing material.

IMPORTANT: The framed opening must be of non-combustible material.

Note: When constructing the framed opening, please ensure there is access to install the gas lines when the unit is installed.

2. For exterior walls, insulate the enclosure to the same degree as the rest of the house, apply vapour barrier and drywall, as per local installation codes. **(Do not insulate the fireplace itself.)**

WARNING: Failure to insulate and add vapor barriers to the inside of the exterior wall will result in operational and performance problems including, but not limited to: excessive condensation on glass doors, poor flame package, carbon, blue flames etc. These are not product related issues.

3. The unit does not have to be completely enclosed in a chase. You must maintain clearances from the vent to combustible materials: See "Clearances" section. Combustible materials can be laid against the side and back standoffs and the stove base.
4. Non-combustible material (ie. tile, slate, etc) may be brought up to and overlap the unit (top and bottom) ensuring that the maximum thickness does not go beyond the 3-1/4" as shown in the diagram below. The faceplate will not be able to be mounted if finished material is beyond 3-1/4" .

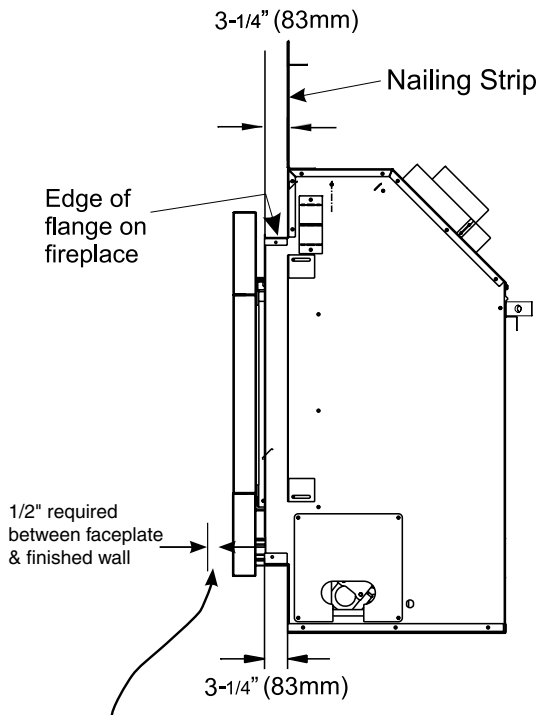

IMPORTANT: 1/2" gap is required between the faceplate and the finished wall when using 4 piece Faceplate (Part # 258-954, 258-957) or Verona Glass Surround (Part # 256-951, 256-957)

5. If material such as brick, stone, etc extends past the faceplate depth (3-1/4"), when finishing around the faceplate, the minimum opening dimensions noted below must be adhered to ensuring for the removal of the faceplate and for the safe operation of this appliance.

NOTE: Spacing of 1" around the completed surround must be adhered to.

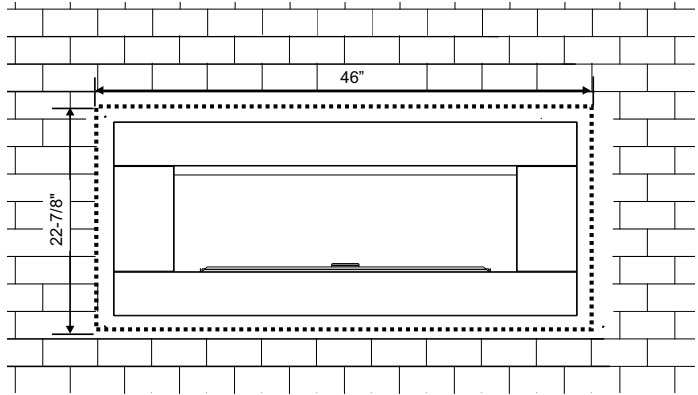

Unit shown with 4 piece faceplate/Verona Glass Surround

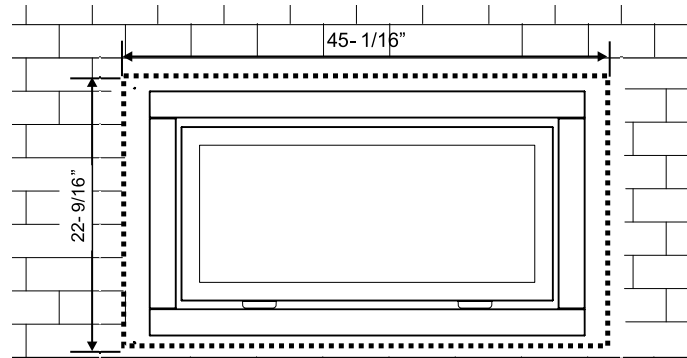

Unit shown with inner and outer door frame

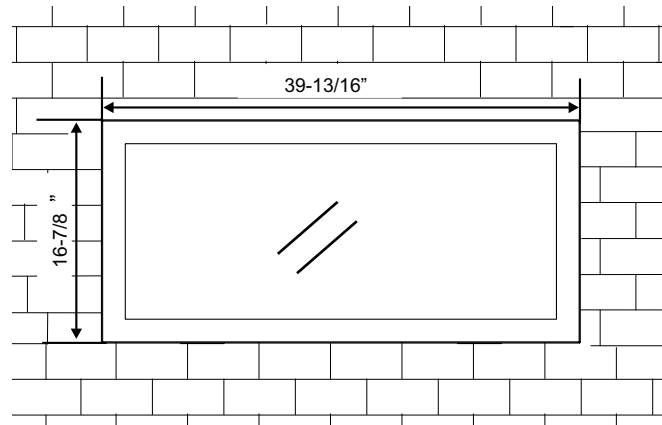

Unit shown with inner door frame only

OPTIONAL FRAMING KIT

- Construct the wood framing, ensure inside dimensions are 53"W x 45-1/2"H as shown below.

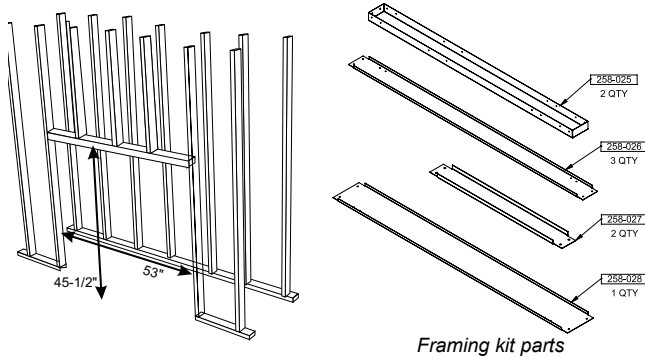

- Bend both side nailing strips from the side of the appliance until positioned as shown below. Determine the overall combined thickness of the non-combustible board + finished material being used. The nailing strips can be adjusted up to 3-1/4".

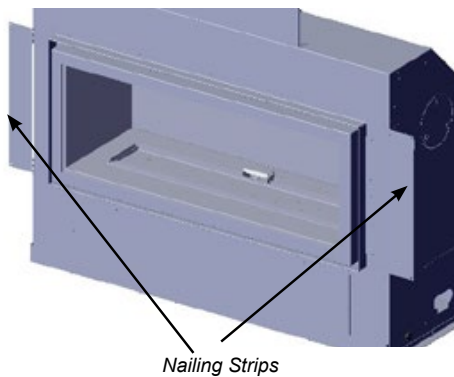

- Adjust the nailing strips by loosening 2 screws on each nailing strip - adjust and retighten screws.
- Attach both vertical studs and secure using 6 screws (2 at bottom, 2 at top and 2 on sides) as shown.

NOTE: Ensure the flat side of the steel stud is facing the wood framing.

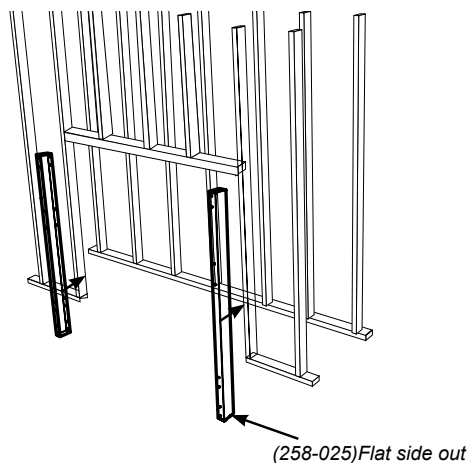

- Secure horizontal steel header stud with 2 screws per side as per diagram.

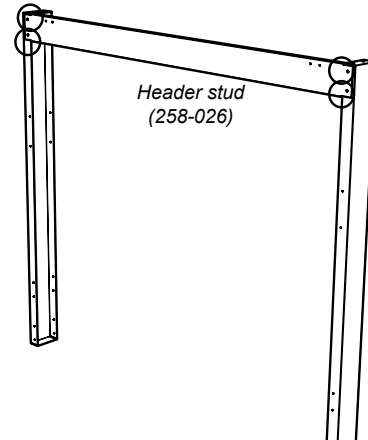

- Slide the unit into position. Hook up gas, venting, electrical and fan (if purchased) prior to installing the remaining steel studs.
- Secure the large horizontal steel stud as shown with 2 screws per side.
- Secure 2 horizontal studs on the lower side of the appliance with 2 screws per side for each stud as shown.

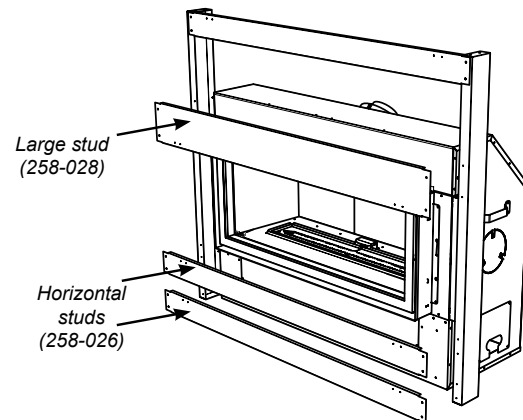

- Secure 2 vertical studs on either side of the appliance with 4 screws per side stud as shown.

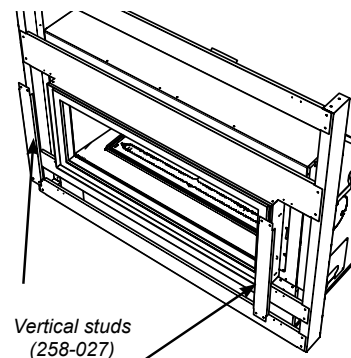

VENTING ARRANGEMENT FOR HORIZONTAL TERMINATIONS

The diagram shows all allowable combinations of vertical runs with horizontal terminations, using one 90° (two 45° elbows equal one 90° elbow). (Not including the starting 45° elbow at the flue collar when using rigid venting.)

Note: Must use optional rigid pipe adaptor (Part# 510-994) when using Rigid Pipe Venting Systems.

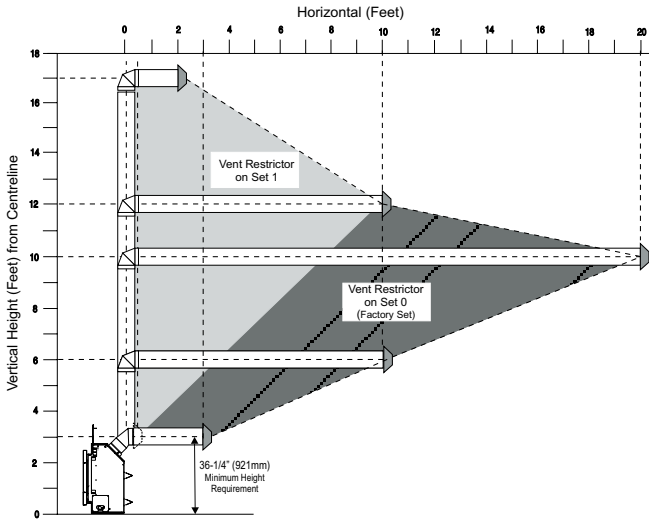

VENTING ARRANGEMENT FOR VERTICAL TERMINATIONS

Vertical Venting with One (1) 90° Elbow (1 - 90° = 2 - 45°)

The shaded area in the diagram shows all allowable combinations of straight vertical and offset to vertical terminations, using one 90° elbow, with **Rigid Pipe Venting Systems**.

Two 45° elbows equal to one 90° elbow, not including the starting 45° elbow at the flue collar.

- Vent must be supported at offsets.
- Minimum distance between elbows is 1 ft. (305mm).
- Maintain clearances to combustibles as listed in the "Clearances" section.
- Horizontal vent must be supported every 3 feet.
- Firestops are required at each floor level and whenever passing through a wall.
- Must use optional rigid pipe adaptor (Part# 510-994) when using rigid pipe vent systems.
- Refer to the "Vent Restrictor Position" section for details on how to change the vent restrictor from the factory setting of Set 0 to Set 1 or Set 2 if required.

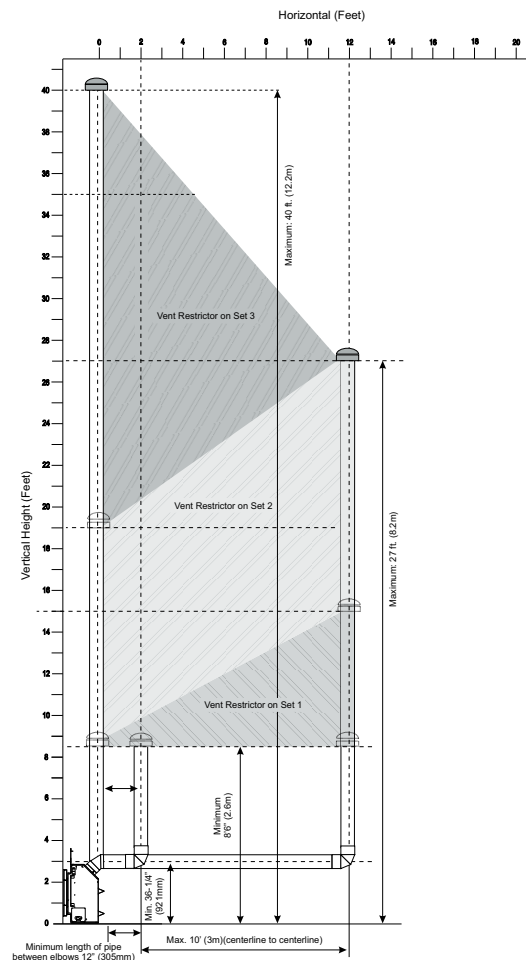

HORIZONTAL TERMINATIONS FLEX VENT 4" X 6-7/8"

These venting systems, in combination with the HZ40E Direct Vent Gas Fireplace, has been tested and listed as a direct vent heater system by Intertek. The location of the termination cap must conform to the requirements in the Vent Terminal Locations diagram in "Exterior Vent Termination Locations" section.

Regency® Direct Vent (Flex) System Termination Kits includes all the parts needed to install the HZ40E using a flexible vent.

FPI Kit #	Length	Contains:
#946-513	2 Feet	<ol style="list-style-type: none"> 1. 6-7/8" flexible outer liner (Kit length) 2. 4" flexible inner liner (Kit length) 3. spring spacers
#946-515	4 Feet	<ol style="list-style-type: none"> 4. thimble 5. AstroCap™ termination cap 6. screws
#946-516	10 Feet	<ol style="list-style-type: none"> 7. tube of Mill Pac 8. plated screws 9. S.S. screws #8 x 1-1/2" drill point

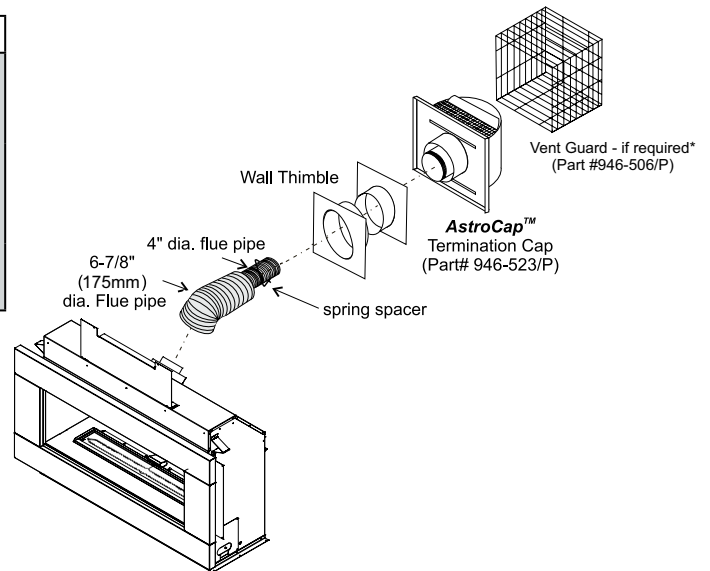

HORIZONTAL TERMINATIONS RIGID PIPE 4" X 6-5/8"

Flat Wall Installation	
Wall Thickness (inches)	Vent Length Required (inches)
4" - 5-1/2"	6"
7" - 8-1/2"	9"
10" - 11-1/2"	12"
9" - 14-1/2"	11" - 14-5/8" Adj. Pipe
15" - 23-1/2"	17" - 24" Adj. Pipe

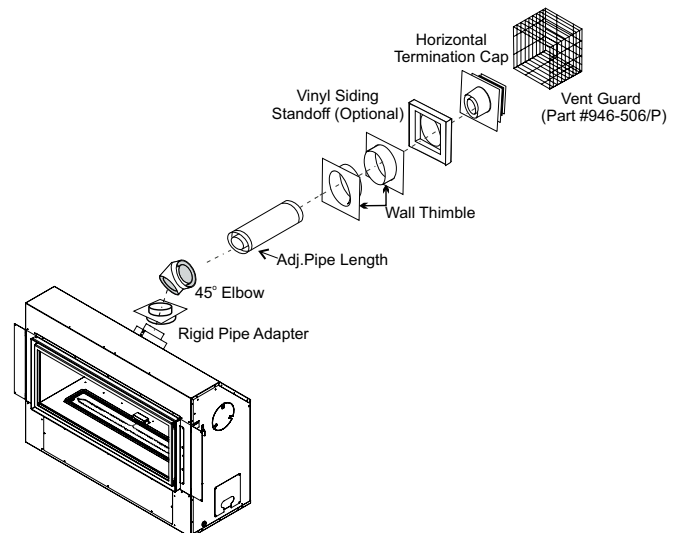

VERTICAL TERMINATIONS RIGID PIPE 4" X 6-5/8"

The minimum components required for a basic vertical termination are:

- 1 Vertical Termination Cap
- 1 45° Elbow
- 1 Rigid Pipe Adaptor (510-994)
- 1 Ceiling Firestop
- 1 Flashing
- 1 Storm Collar
- 1 Length of pipe to suit wall thickness (see chart)

Galvanized pipe is desirable above the roof line due to its higher corrosion resistance. Continue to add pipe sections through the flashing until the height of the vent cap meets the minimum height requirements specified in chart below or local codes. Note that for steep roof pitches, the vertical height must be increased. A poor draft, or down drafting can result from high wind conditions near big trees or adjoining roof lines, in these cases, increasing the vent height may solve the problem.

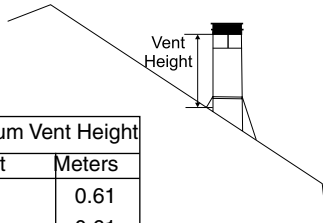

Roof Pitch	Minimum Vent Height	
	Feet	Meters
flat to 7/12	2	0.61
over 7/12 to 8/12	2	0.61
over 8/12 to 9/12	2	0.61
over 9/12 to 10/12	2.5	0.76
over 10/12 to 11/12	3.25	0.99
over 11/12 to 12/12	4	1.22
over 12/12 to 14/12	5	1.52
over 14/12 to 16/12	6	1.83
over 16/12 to 18/12	7	2.13
over 18/12 to 20/12	7.5	2.29
over 20/12 to 21/12	8	2.44

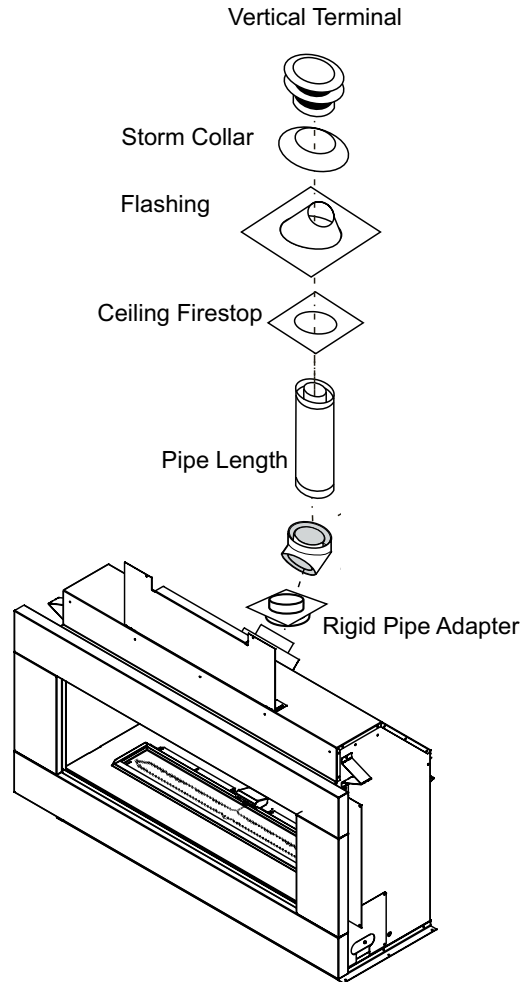

WARNING:

Do not combine venting components from different venting systems.

However use of the the AstroCap™ and FPI Riser is acceptable with all systems.

This product has been evaluated by Intertek for using a Rigid Pipe Adaptor in conjunction with Duravent Direct-Vent, Selkirk Direct-Temp, Ameri Vent Direct Venting, ICC Excel Direct and Security Secure Vent systems. Use of these systems with the Rigid Pipe adaptor is deemed acceptable and does not affect the Intertek WHI listing of components.

When using Rigid Vent other than Simpson Dura-Vent, 3 screws must be used to secure rigid pipe to adaptor.

The FPI AstroCap™ and FPI Riser Vent terminal are certified for installations using FPI venting systems as well as Simpson Dura-Vent® Direct Vent, American Metal Products Ameri Vent Direct Vent, Security Secure Vent®, ICC Excel, Selkirk Direct-Temp. AstroCap™ is a proprietary trademark of FPI Fireplace Products International Ltd. Dura-Vent® and Direct Vent are registered and/or proprietary trademarks of Simpson Dura-Vent Co. Inc.