

Hampton GCI60-2 Cast Iron Pellet Insert

Model	GCI60-2
Heat Output BTUs	7,817-38,437 BTUs
Emissions (grams/hr) EPA Certified	1.9 gram/hr
Efficiency (EPA HHV)*/**	78%
Efficiency (EPA LHV)	86%
Flue Size	4" (102mm)
US Biomass Tax Rebate Eligible**/**	Yes

*US Biomass Tax Rebate eligibility is based on the HHV value being greater than or equal to 75%.

**When using 4" (102 mm) to 6" (152 mm) flue increaser. See technical manual for further information.

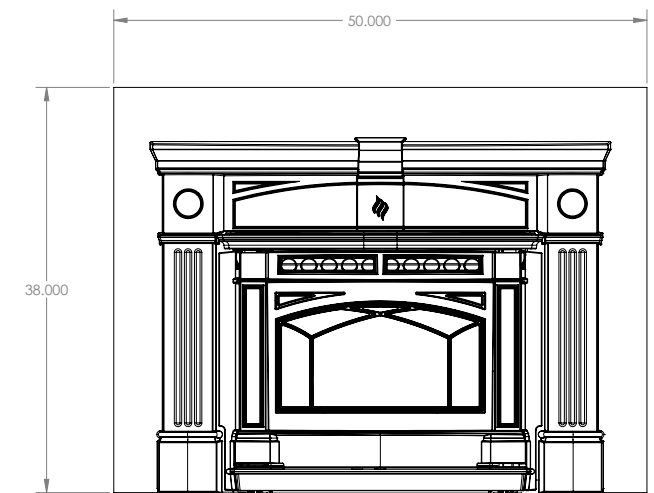
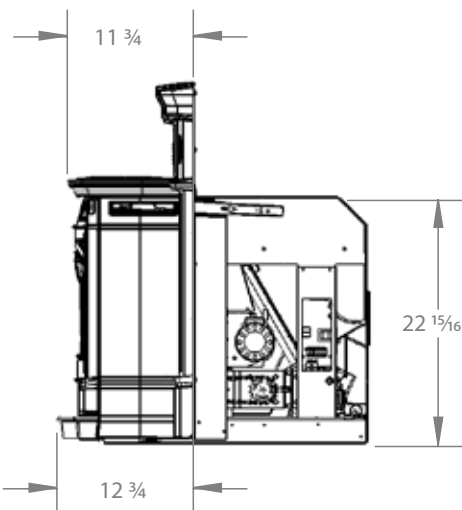
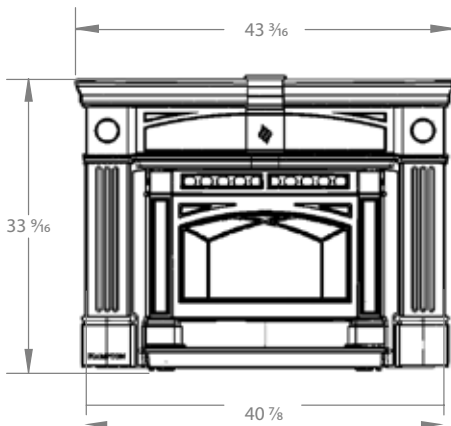
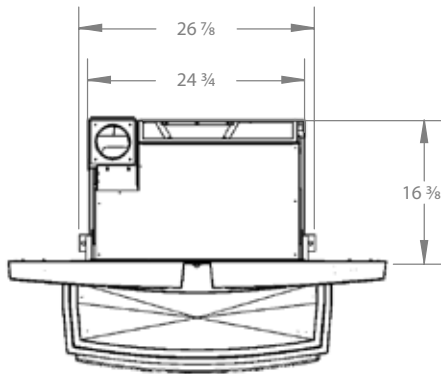

Filler Panels Dimensions

Installation

CLEARANCES TO COMBUSTIBLES:

INSTALLED AS A FIREPLACE INSERT STOVE MODEL (FPI)

Minimum clearances to combustible materials:

A	Sidewall to center of unit	24" (610 mm)
B	Sidewall to surround panel	2" (51 mm)
C	Bottom of unit to an unshielded 12" (305 mm) mantel	33" (838 mm)
D	Unit to top facing protruding 3/4" (19 mm)	0"
E	Unit to side facing protruding 3/4" (19 mm)	0"
F	From door opening of unit to edge of floor protection	6" (152 mm)
G	From side of unit to edge of floor protection	6" (152 mm)

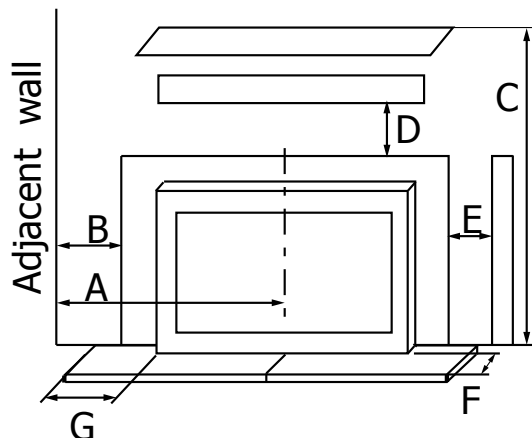

Figure 5: GCI60 Clearance to Combustibles.

These dimensions are minimum clearances. It is recommended that you ensure sufficient room for servicing, routine cleaning and maintenance.

The unit must be installed with a minimum of 6" (152 mm) of floor protection in front of and to the sides of the door opening.

Note: Facing refers to the cast surround.
F & G are measured from the fuel door opening.

MINIMUM FIREPLACE OPENING:

Your fireplace opening requires the following minimum sizes:

GCI60

Height: 23" (584mm)

Width: 27" (686mm)

Depth: 16" (406mm)

Cast iron Surround : Height 33-9/16" (852mm)

Width 40-7/8" (1038mm)

Fuel door opening : Height 10-1/4" (260mm)

Width 18-9/16" (471mm)

VENT TERMINATION REQUIREMENTS:

IT IS RECOMMENDED THAT YOUR PELLET STOVE BE INSTALLED BY AN AUTHORIZED DEALER/INSTALLER.

Table 2: Use in conjunction with Figure 6 for allowable exterior vent termination locations.

Letter	Minimum Clearance	Description
A	24 in (61 cm)	Above grass, top of plants, wood, or any other combustible materials.
B	48 in (122 cm)	Beside/below any door or window that may be opened. (18" (46 cm) if outside fresh air installed.)
C	12 in (30 cm)	Above any door or window that may be opened. (9" (23 cm) if outside fresh air installed.)
D	24 in (61 cm)	To any adjacent building, fences and protruding parts of the structure.
E	24 in (61 cm)	Below any eave or roof overhang
F	12 in (30 cm)	To outside corner.
G	12 in (30 cm)	To inside corner, combustible wall (vertical and horizontal terminations).
H	3 ft (91 cm) within a height of 15 ft (4.5 m) above the meter/regulator assembly	To each side of center line extended above natural gas or propane meter/regulator assembly or mechanical vent.
I	3 ft (91 cm)	From any forced air intake of other appliance
J	12 in (30 cm)	Clearance to non-mechanical air supply inlet to building, or the combustion air inlet to any appliance.
K	24 in (61 cm)	Clearance above roof line for vertical terminations.
L	7 ft (2.13 m)	Clearance above paved sidewalk or paved driveway located on public property.

- Do not terminate the vent in any enclosed or semi-enclosed areas such as a carport, garage, attic, crawlspace, narrow walkway, closely fenced area, under a sundeck or porch, or any location that can build up a concentration of fumes such as stairwells, covered breezeway, etc.

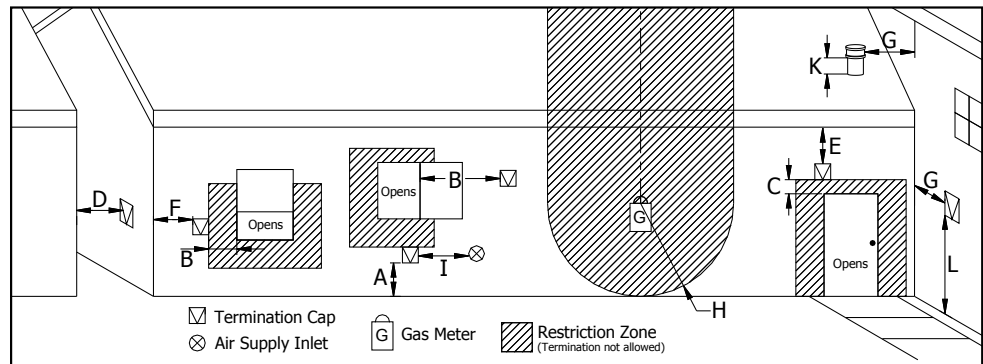

Figure 6: Use in conjunction with Table 2 for allowable exterior vent termination locations.

- Vent surfaces can become hot enough to cause burns if touched by children. Non-combustible shielding or guards may be required.
- Termination must exhaust above the inlet elevation. It is recommended that at least five feet of vertical pipe be installed outside when the appliance is vented directly through a wall, to create some natural draft to prevent the possibility of smoke or odor during appliance shut down or power failure. This will keep exhaust from causing a nuisance or hazard from exposing people or shrubs to high temperatures. In any case, the safest and preferred venting method is to extend the vent through the roof vertically.
- Distance from the bottom of the termination and grade is 12" (30 cm) minimum. This is conditional upon the plants and nature of grade surface. The exhaust gases are hot enough to ignite grass, plants and shrubs located in the vicinity of termination. The grade surface must not be lawn.
- If the unit is incorrectly vented or the air to fuel mixture is out of balance, a slight discoloration of the exterior of the house might occur. Since these factors are beyond the control of Regency Fireplace Products, we grant no guarantee against such incidents.
- Horizontal terminations must extend at least 12" (30 cm) away from the building.

NOTE: Venting terminals shall not be recessed into walls or siding.

Installation requirements when meeting the 78% (HHV)

A 4" chimney liner is affixed to a 4" to 6" increaser & either a 5.5" or 6" liner taken from the increaser to the top of the chimney. See diagram below.

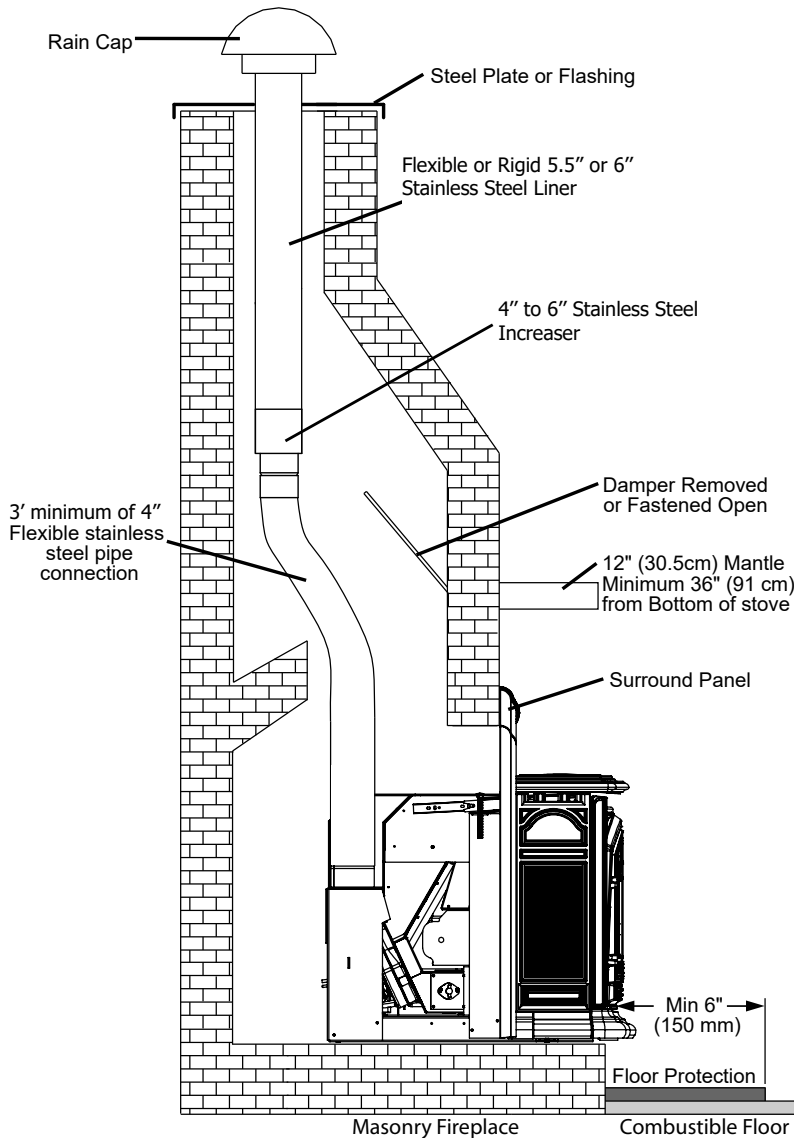

Figure 9: Masonry fireplace installation.

When installing the insert into a masonry fireplace, **DO NOT** remove any bricks or masonry, with the following exception: masonry or steel, including the damper plate, may be removed from the smoke

shelf and adjacent damper frame, if necessary, to accommodate a chimney liner. Do this only if their removal will not weaken the structure of the fireplace and chimney, and will not reduce protection for combustible materials to less than that required by the national building code. When installing the fireplace insert into a zero clearance fireplace, **DO NOT** cut or modify any factory firebox parts.

MASONRY FIREPLACE INSTALLATION:

A non-combustible manufactured hearth pad (min. 24 gauge galvanized steel or similar) must cover combustible flooring underneath, as well as 6" (150 mm) in front of the heater and 6" (150 mm) to the side of the heater.

1. Install the hearth pad.
2. Lock any existing fireplace dampers in the open position.
3. Set leveling leg to approximate height.
4. Connect a Exhaust Starter Quick Connect straight to the exhaust pipe.
5. This fireplace insert must be installed with a chimney liner of 4" diameter extending a minimum of 3' from the fireplace insert to the 4" to 6" increaser. A 5.5 or 6 inch stainless steel liner is then attached to the 4" to 6" increaser to the top of the chimney. The chimney liner must conform to the Class 3 requirements of CAN/ULC-S635, Standard for Lining Systems for Existing Masonry or Factory-Built Chimneys and Vents, or CAN/ULC-S640, Standard for Lining Systems for New Masonry Chimneys.
6. It is necessary to permanently seal any opening between the masonry of the fireplace and the facing masonry.

POSITIVE FLUE CONNECTION WITHOUT A FULL RELINE (USA ONLY):

This unit does not require a full reline (in USA only) when installing into a masonry fireplace, however, it is recommended to ensure proper drafting of the appliance.

IMPORTANT: Ensure the chimney and firebox are cleaned and free of all debris, including soot and ashes, before proceeding with this installation. If it is not clean soot maybe blown into the room through the unit's blower. Ensure the fireplace and chimney have not deteriorated in any way. If there is any sign of corrosion or damage in the chimney the unit can not be installed. This unit can be installing in a masonry fireplace built to (UBC 37 or ULC S628 standards) or a factory built fireplace (built to UL 127 or ULC S610 standards).

1. Install the hearth pad. The floor 6" (150 mm) in front of the unit and 6" (150 mm) to each side of the unit must be protected with a non-combustible hearth pad.
2. The vent connector from the insert must extend a minimum of 18" above the chimney seal plate. The chimney seal plate area must be sealed to prevent the exhaust from the chimney from coming back into the fireplace and prevent air from the fireplace from entering the chimney which will affect proper drafting of appliance.

A qualified installer should evaluate the existing fireplace to determine the best method for achieving a positive flue connection between the vent pipe or liner and the chimney. Whatever method used must effectively seal the area to prevent room air passage to the chimney cavity of the fireplace. A couple examples of Approved Methods of Achieving a Positive Flue Connection are:

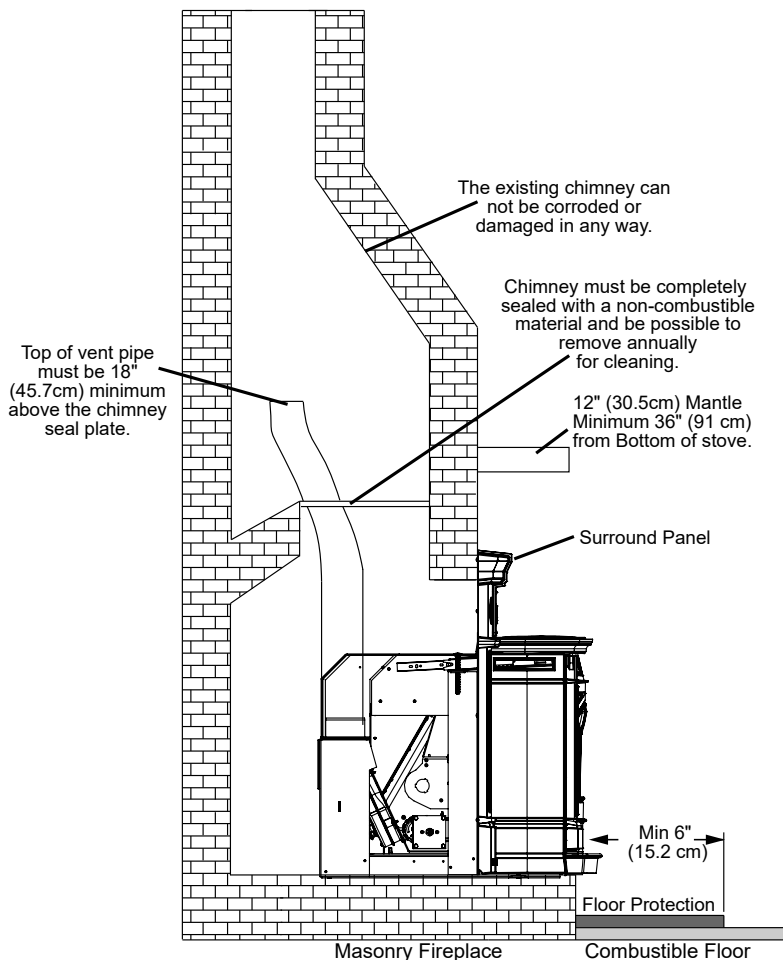

- a) Secure a seal-off plate (i.e. 22-gage sheet steel) in the masonry fireplace throat using masonry screws.
 - b) Pack non-combustible material (i.e. rockwool) around the vent pipe or using a flue adapter.
3. Set leveling leg to approximate height.
 4. Connect the Exhaust Starter Quick Connect straight to the exhaust pipe.

Figure 10: Masonry fireplace positive flue installation.

IMPORTANT: The chimney seal plate must be removed for the annually chimney cleaning as ash will build up on top of the plate.

BUILT-IN INSTALLATION:

Installation without a masonry fireplace -

The GCI60 can be installed without an existing masonry fireplace by building an enclosure for the unit to be installed in. This enclosure must be a minimum of 18" deep, 36" wide and 23-1/4" high and made with 1/2" noncombustible cement board. The floor of the enclosure must consist of a minimum of 1-1/4" air space and a layer of 1/2" noncombustible cement board and a layer of tile. The air space must be supported with sheet metal studs and have no combustible material in the air space. All venting for Built-In installation must use PL or L venting and be installed with vent manufacturer's recommended clearances. Refer to page 11 for Clearances to Combustibles.

Note: The Built in installation is not approved for the 78% (HHV) Higher Heating Value.

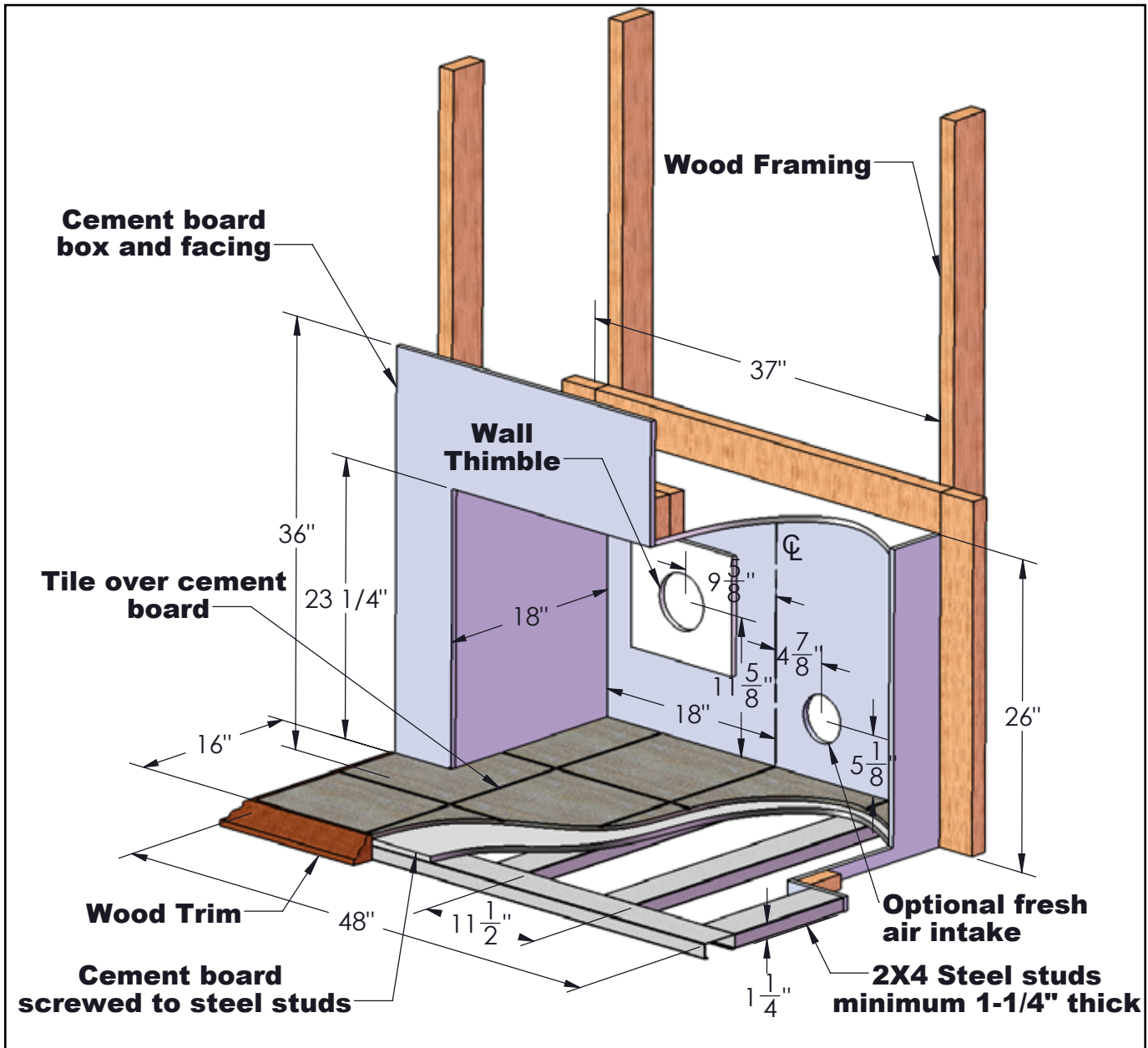

Figure 11: Built-In Specifications

HORIZONTAL EXHAUST THROUGH WALL INSTALLATION:

Vent installation: install vent at clearances specified by the vent manufacturer.

A chimney connector shall not pass through an attic or roof space, closet or similar concealed spaces, or a floor, or ceiling. Where passage through a wall or partition of combustible construction is desired, the installation must conform to CAN/CSA-B365 Installation Code for Solid-Fuel-Burning Appliances and Equipment and with all local regulations, including those referring to regional and national. Only use venting of L or PL type or corn certified venting if corn will be burned as a fuel with an inside diameter of 4 inches (100 mm). All joints in the exhaust venting system must be fastened with at least three (3) screws.

NOTE:

- It is recommended that horizontal through wall installations have a "T" and 3 to 5 feet (91 to 152 cm) of vertical pipe in the system to help naturally draft the unit in the event of extreme weather or a power outage. This may also be required if a proper burn cannot be maintained, after the stove has been tested and the airflow set. This is due to the back pressure in the exhaust caused by airflow around the structure.
 - Follow vent manufacturer guidelines for installation, clearance to combustibles, and sealing of venting. High temp Sealant must be used when connecting vent pipe to the unit's starter pipe. Improper seals at the vent joints may cause combustion by-products to leak into the room where installed - **seal as required by vent manufacturer.**
1. Locate the center of the exhaust pipe on the wall, refer to pellet vent manufacturer installation instructions for correct hole size and clearance to combustibles.
 2. Install the wall thimble as per the instructions written on the thimble. Maintain an effective vapour barrier in accordance with local building codes.
 3. Install a length of vent pipe into the wall thimble. Try not to have joints inside the thimble. The pipe should install easily into the thimble.
 4. Connect the exhaust vent pipe to the exhaust pipe on the stove. Seal the connection with high temperature silicone.
 5. The pipe must extend at least 12" (30 cm) away from the building. If necessary, bring another length of pipe to the outside of the home to connect to the first section. Do not forget to place high temperature silicone around the pipe that passes through the thimble if required by vent manufacturer.
 6. Install vent termination or 3-5' of vertical pipe and a 90 degree elbow and vent termination.

RECOMMENDED - THROUGH WALL WITH VERTICAL RISE AND HORIZONTAL TERMINATION INSTALLATION:

NOTE - This venting configuration is only for use with the Built-In installation.

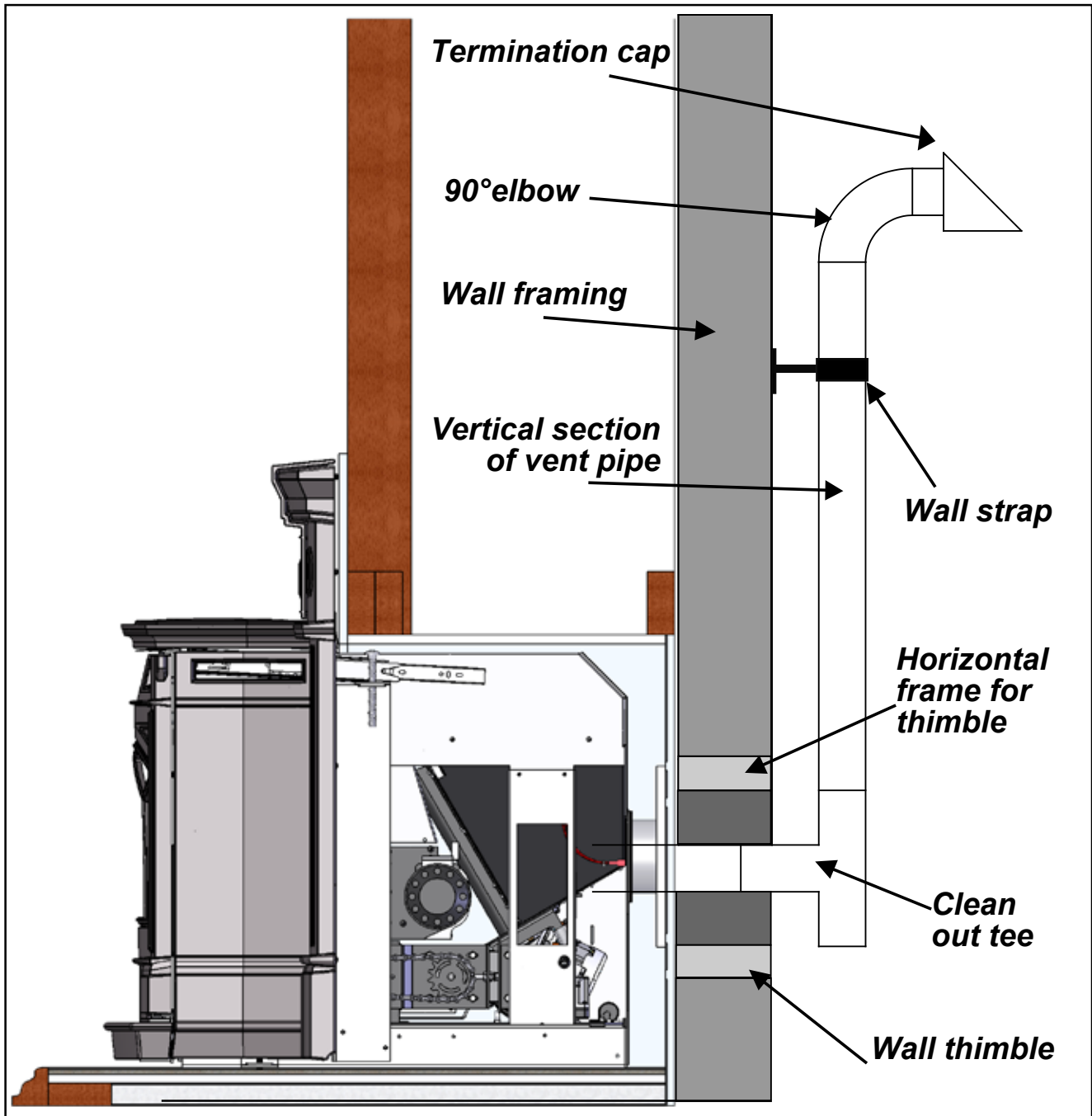

Figure 12: Venting horizontally with rise.

OUTSIDE VERTICAL INSTALLATIONS:

To accomplish an outside vertical pipe installation, follow the "HORIZONTAL EXHAUST THROUGH WALL INSTALLATIONS" section and then finish it by performing the following.

1. Install a tee with clean out on the outside of the house.
2. Install PL vent upward from the tee. Make sure that you install support brackets to keep the vent straight and secure. All joints in the exhaust venting system must be fastened with at least three (3) screws.
3. Install ceiling thimble and secure the flashing as you go through the roof.
4. Ensure that the rain cap is a minimum of 24" (61 cm) above the roof.

NOTE - This venting configuration is only for use with the Built-In installation.

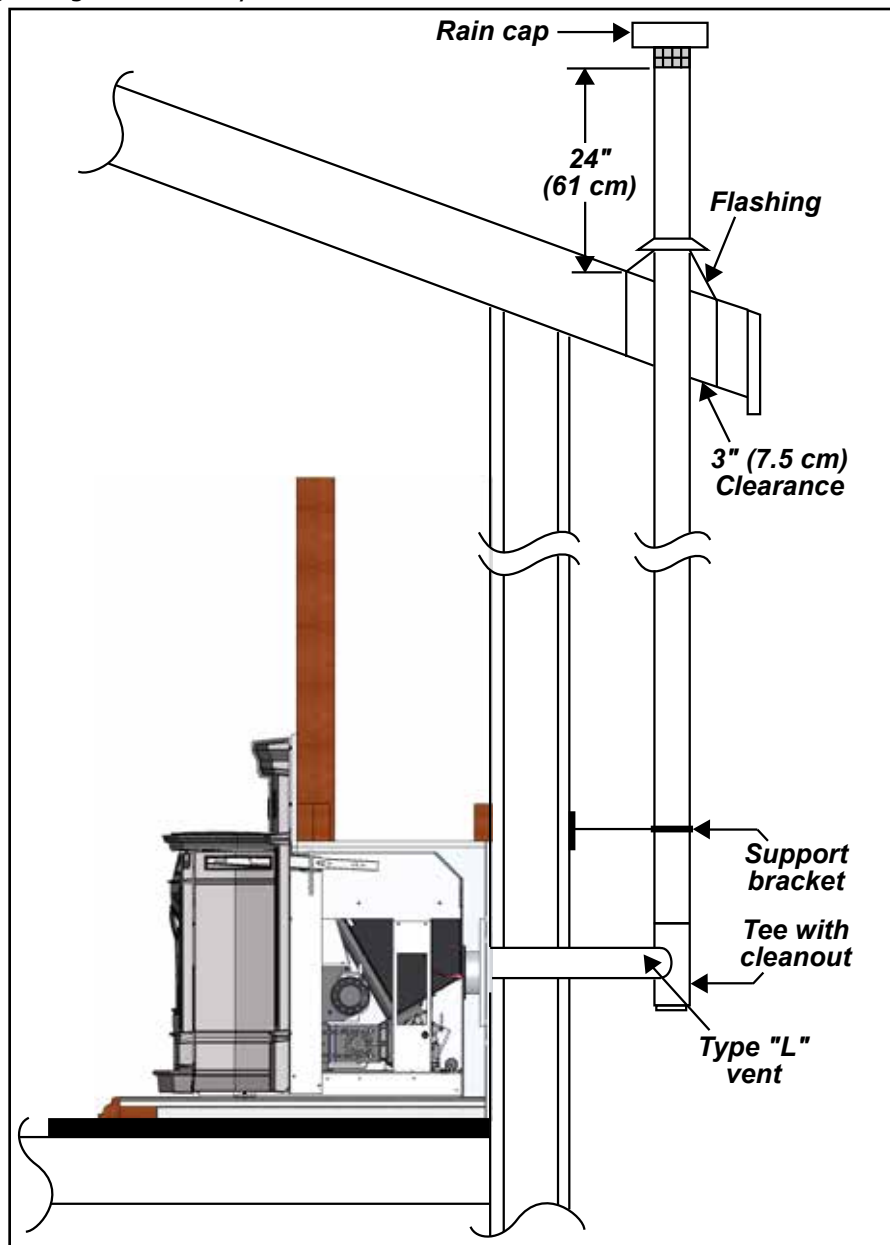

Figure 13: Outside Vertical Installation.

INSIDE VERTICAL INSTALLATIONS:

1. Install a tee or 90° elbow on the inside of the house.
2. Install PL vent upward from the tee. Make sure that you install support brackets to keep the vent straight and secure. All joints in the exhaust venting system must be fastened with at least three (3) screws.
3. Install ceiling thimble and secure the flashing as you go through the roof.
4. Ensure that the rain cap is a minimum of 24" (61 cm) above the roof.

NOTE - This venting configuration is only for use with the Built-In installation.

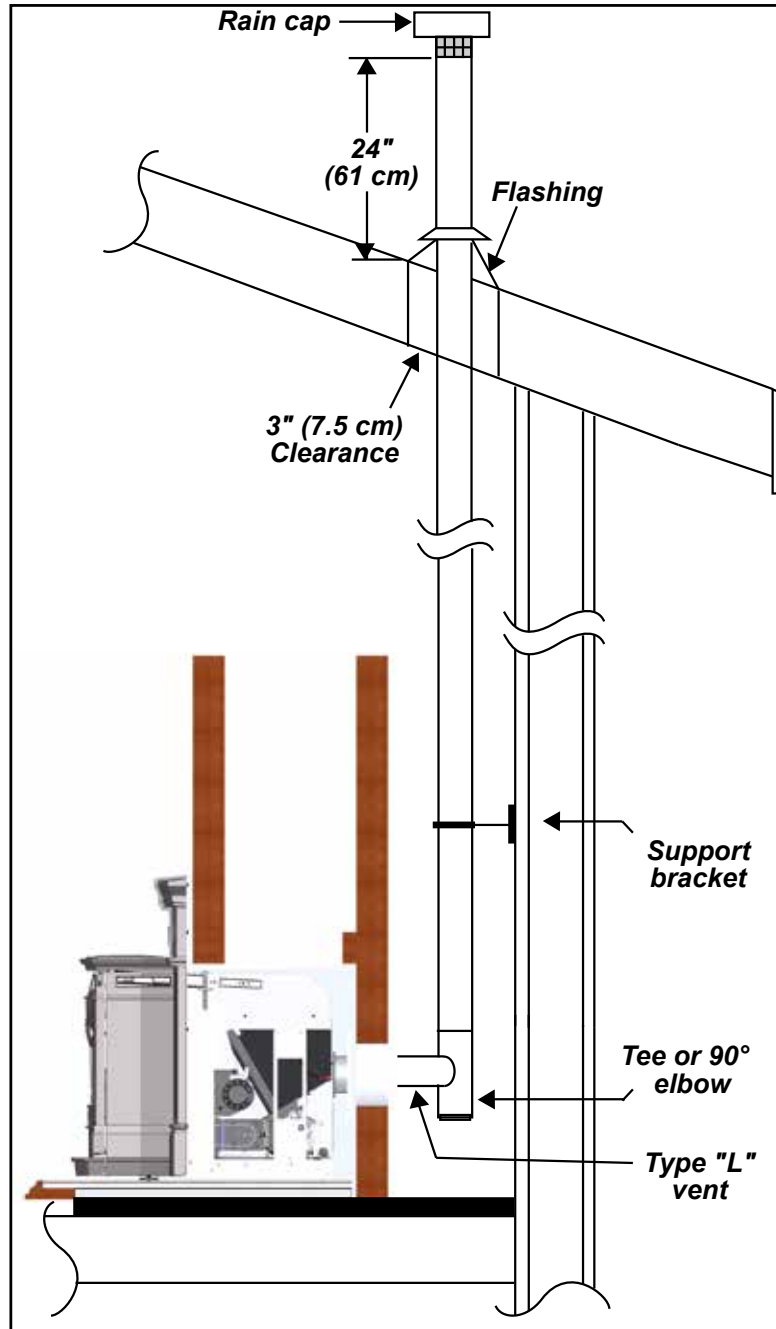

Figure 14: Inside Vertical Venting.