

City Series CV60E-1 Gas Fireplace

MODEL	CV60E-NG1	CV60E-LP1
Fuel Type	Natural Gas	Propane
Minimum Supply Pressure	5" W.C. (1.25 kPa)	11" W.C. (2.73 kPa)
Manifold Pressure - High	3.8" W.C. (0.94 kPa)	10.5" W.C. (2.62 kPa)
Manifold Pressure - Low	1.1" W.C. (0.27 kPa)	2.9" W.C. (0.72 kPa)
Orifice Size - Altitude 0-4500 ft.	# 32 DMS	# 50 DMS
Minimum Input Altitude 0-4500 ft. (0-1372m)	21,000 Btu/h (6.15 kW)	19,500 Btu/h (5.71 kW)
Maximum Input Altitude 0-4500 ft. (0-1372m)	39,000 Btu/h (11.42 kW)	36,000 Btu/h (10.54 kW)
Vent Sizing	5" Inner /8" Outer	5" Inner /8" Outer



NOTE: This model comes with a 5" inner and 8" outer collar (127 mm x 203 mm) which must be reduced to 4" inner x 6-5/8" outer (102 mm x 168 mm) in all applications when used as a power vent system. See power vent manual for details.

CV60E-1 Dimensions

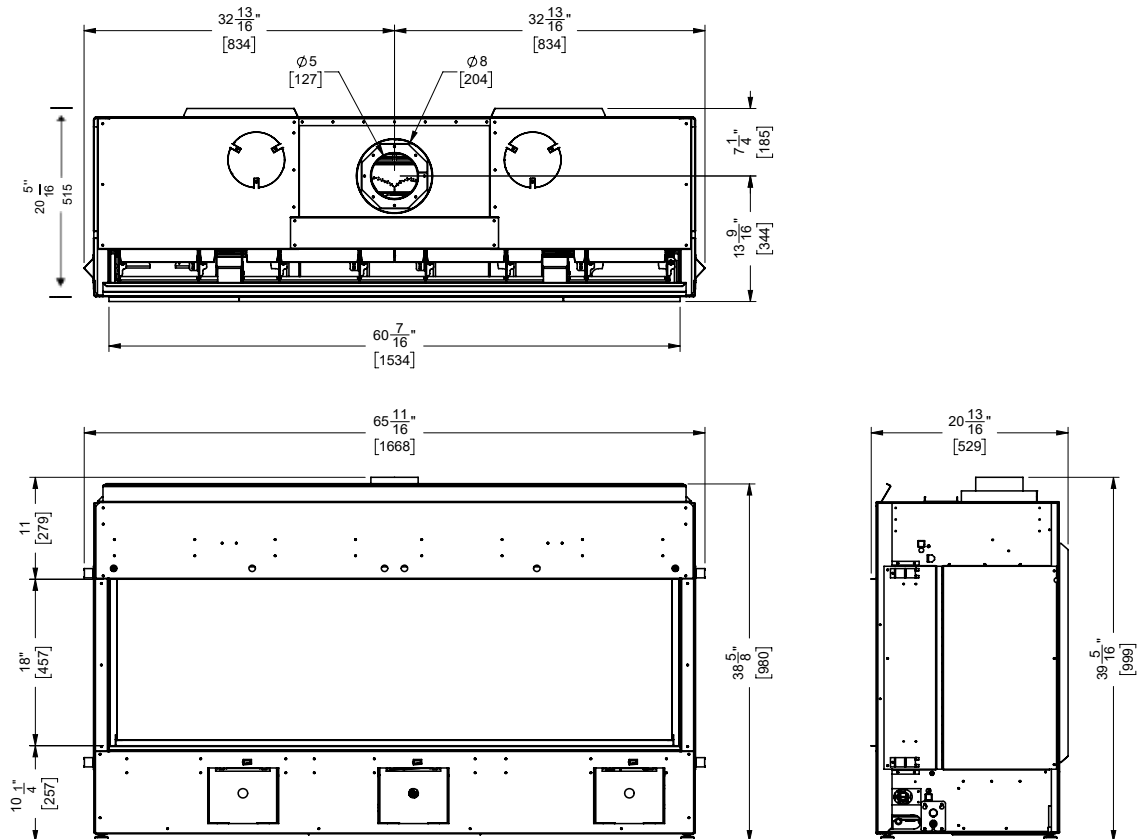

CLEARANCES

The clearances listed below are minimum distances unless otherwise stated.

A major cause of chimney-related fires is failure to maintain required clearances (air space) to combustible materials. It is of the greatest importance that this fireplace and vent system be installed only in accordance with these instructions.

Clearance	Dimension	Measured From:
A1: Mantel Height (min.)	**	Top of Fireplace Opening
A: From Floor (min.)	10-1/4" (260 mm)	Bottom of fireplace opening
B: Sidewall (on one side) min.	8" (203 mm)	Side of fireplace opening
C: Enclosure Width (min.)	65-11/16" (1668 mm)	Side of fireplace opening
D: Mantel Depth (max.)	**	
E: Alcove Width	109-1/2" (2781 mm)	Sidewall to sidewall (minimum)
F: Alcove Depth	35" (889 mm)	Front to unit (maximum)
G: Convection Air Outlet Opening Offset (min.)	*0-2" (0-51 mm)	Max. offset from top of chase enclosure
H: Convection Air Outlet	*180 in ² (1161 cm ²)	
I: Framing Depth (min.)	20-5/16" (516 mm)	From back wall to chase front
J: Opening Height	18" (457 mm)	Bottom/top of fireplace opening
K: minimum clearance to ceiling	1-3/4" (44 mm)	Top of chase to ceiling
L: Chase Enclosure (min.)	81-1/4" (2064 mm)	From base of unit/floor to top of enclosure
M: Clearance to Sprinkler Head (min.)	36" (914mm)	Perpendicular from chase grill
Hearth	0"	No hearth required

** See mantel clearances chart in the manual.

Flue Clearances to Combustibles	
Horizontal - Top	3"
Horizontal - Side	2"
Horizontal - Bottom	2"
Vertical	2"
Passing through wall/floor/ceiling - when firestop is used.	1-1/2"

Note: This appliance uses 5" x 8" venting.

The **HeatWave** Duct Kit has different clearance and framing requirements, check the **HeatWave** manual for details.

Caution Requirements

The top, back and sides of the fireplace are defined by standoffs. The metal ends of the standoff may **NOT** be recessed into combustible construction.

WARNING

Fire hazard is an extreme risk if these clearances (air space) to combustible materials are not adhered to. It is of greatest importance that this fireplace and vent system be installed only in accordance with these instructions.

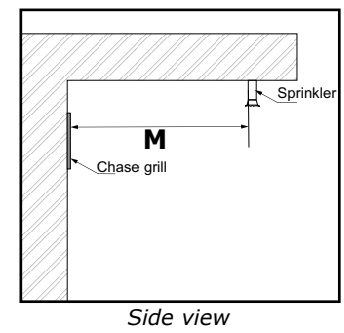
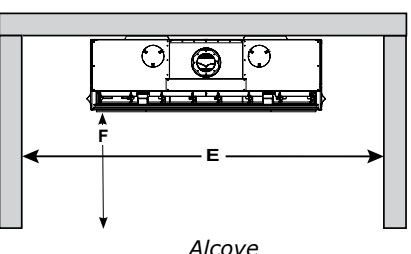
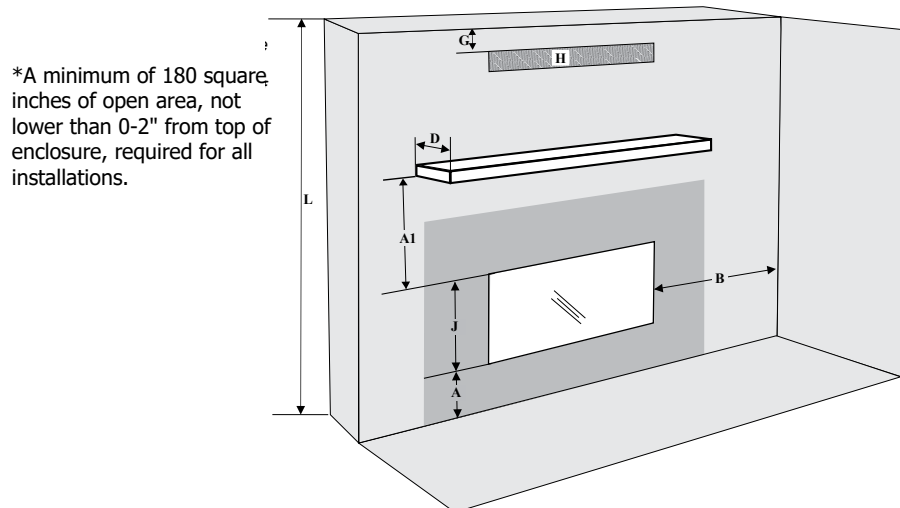

CLEARANCES

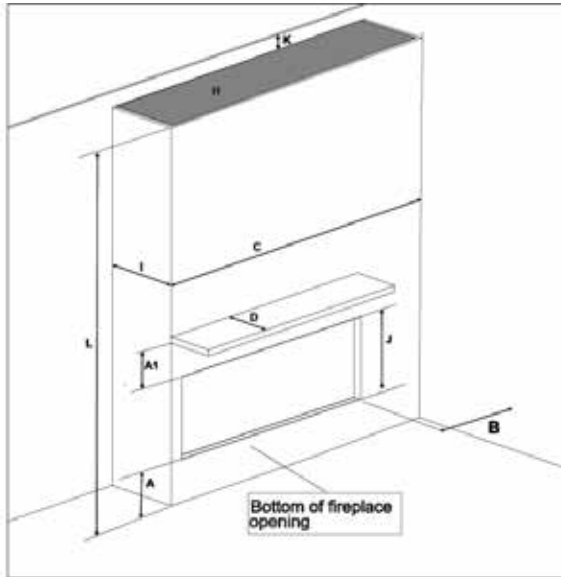

Floor to ceiling with top opening.

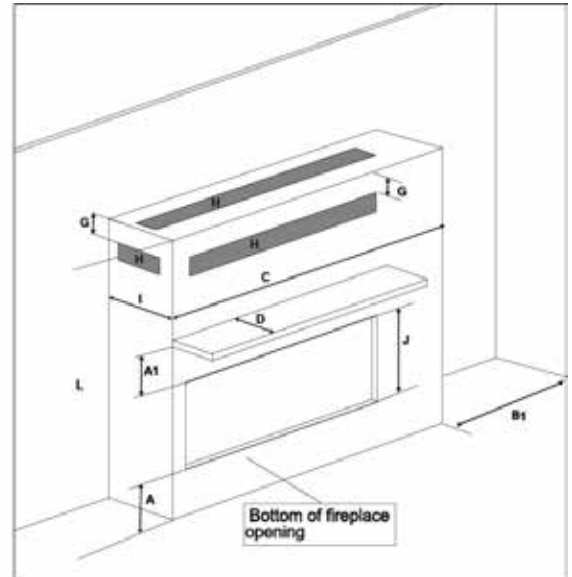

Full framing with vents in front, sides, or top.

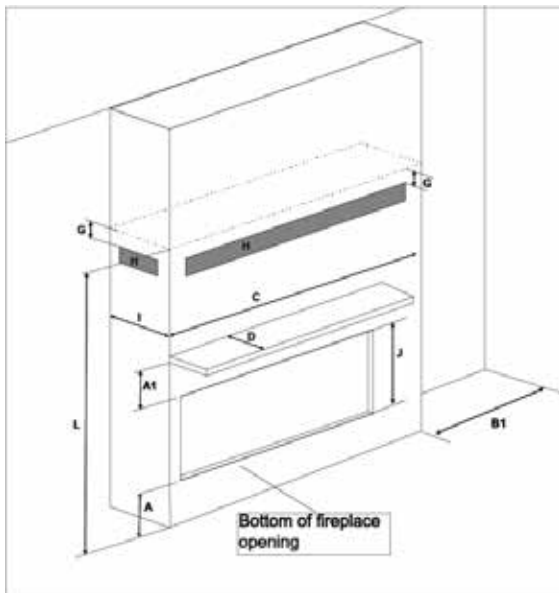

Full framing with low vents in front or sides.

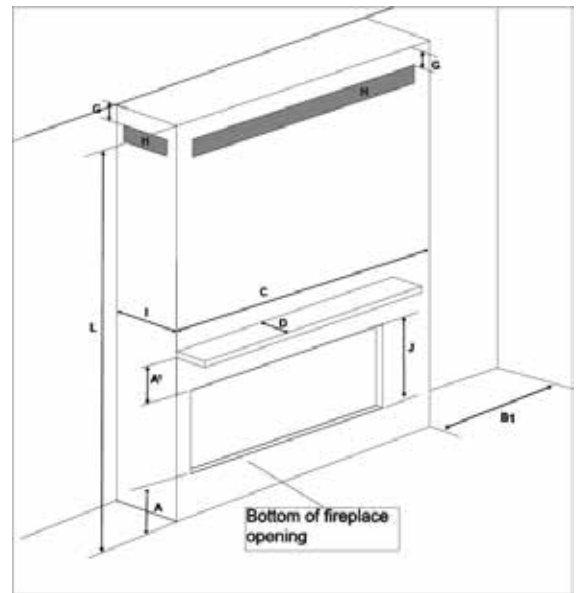

Full framing with vents in front or sides.

MANTEL CLEARANCES

Combustible mantel clearances from top of front facing are shown in the diagram below.

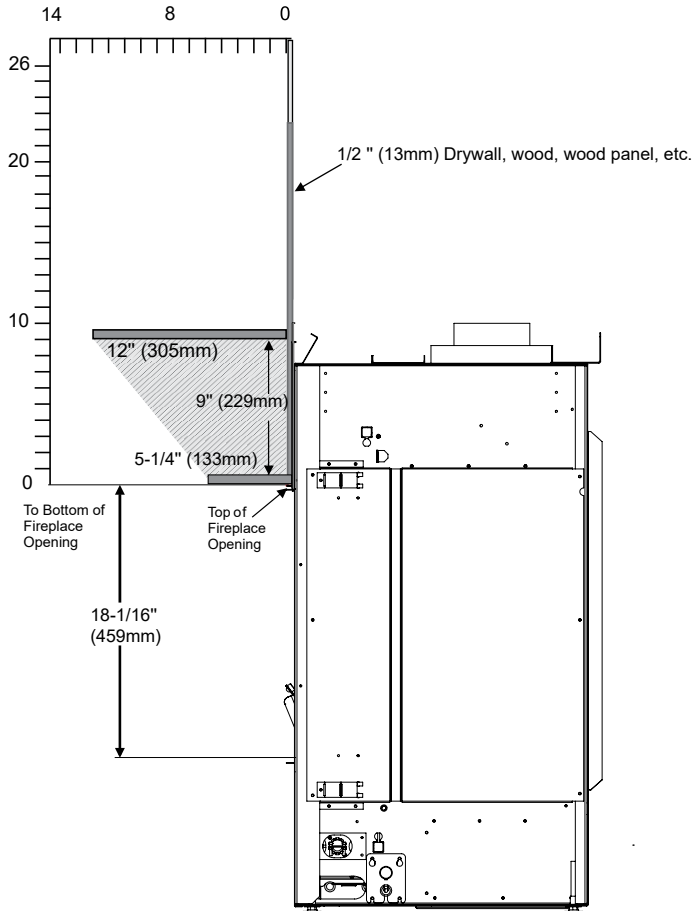

Mantel Leg Clearances

Combustible mantel leg clearances as per diagram:

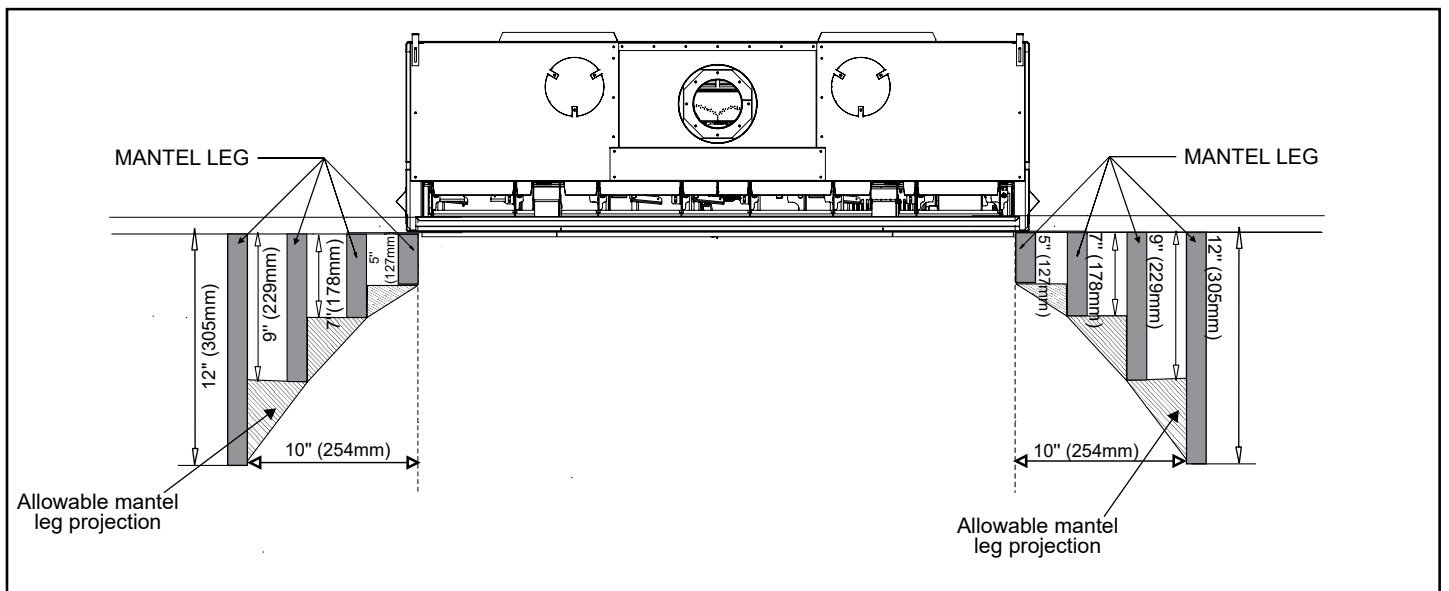

FRAMING

NOTE: Framing may be constructed of combustible material (I.e. 2 x 4) and does not require steel studs.

Framing Dimensions	Description	CV60E
A	Framing Height	44-3/4" (1137 mm)
B*	Framing Width	65-11/16" (1668 mm)
C*	Framing Depth	20-5/16" (516 mm)
D	Minimum Height to Combustibles	81-1/4" (2038 mm)
E	Corner Wall Depth	73 7/16" (1866 mm)
F	Corner Facing Wall Depth	103-7/8" (2638 mm)
G	Vent Centerline Height	58-3/16" (1478 mm)

** See manual for alternate Gas/ Electrical connection options

The lift handles add approximately 4 inches to the width of the appliance. If the appliance will be lifted off the ground and slid into the framed opening, we suggest changing the framing width from 65-11/16" to 69-11/16" to allow the appliance to slide into position with the handles on, or creating a platform in front of the framed opening where the lift handles can be removed prior to installation. If the framing is raised off the ground you can install it after the appliance is in place with handles removed to maintain the framing width of 65-11/16". Ensure that the wood base for the appliance is strong enough to support its shipping weight of 480 pounds.

Note: A combined minimum of 180 square inches of open area is required for the convection air outlet to cool the enclosure. Ensure clearances for convection air outlets are met. See clearances in this manual for different ways to achieve this.

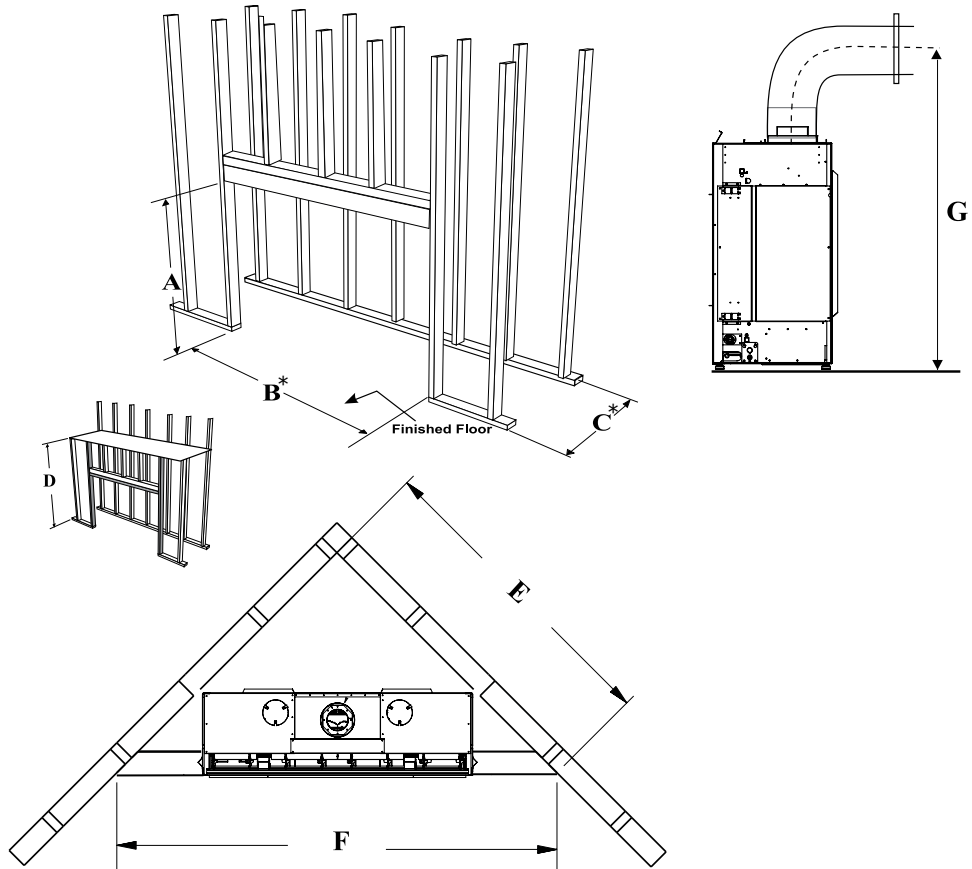

Note: This appliance must be installed on a solid floor surface such as a plywood floor which must be the full width and depth of the appliance.

* The framing depth/width does not take into account drywall/wood or similar materials against the back /side wall. The framing depth will need to change based on the thickness of the material.
 Example: B - 65 11/16" framing width +1/2" drywall per side = 66 11/16")
 Example: C - 20 5/16" framing depth +1/2" drywall = 20 13/16")

HORIZONTAL TERMINATIONS

Flex Vent 5" x 8"

These venting systems, in combination with the CV60E Direct Vent Gas Fireplace, has been tested and listed as a direct vent heater system by Intertek. The location of the termination cap must conform to the requirements in the Vent Terminal Locations diagram in "Exterior Vent Termination Locations" section.

Regency® Direct Vent (Flex) System Termination Kits include all the parts needed to install the CV60E using a flexible vent.

FPI Kit #	Length	Contains:
#946-615	4 Feet	1) 8" flexible liner (Kit length) 2) 5" flexible liner (Kit length) 3) spring spacers
#946-618	6 Feet	4) thimble 5) AstroCap XL termination cap 6) screws
#946-616	10 Feet	7) tube of Mill Pac 8) plated screws 9) S.S. screws #8 x 1-1/2" drill point 10) vinyl siding standoff

Notes:

1. Liner sections should be continuous without any joints or seams.
2. Only Flex pipe purchased from Regency® may be used for Flex installations
3. Horizontal vent must be supported every 3 feet.
4. Regency® Direct Vent System (Flex) is only approved for horizontal terminations.
5. Flex system can only be used up to a maximum continuous vent length of up to 10 feet. If longer runs are required, rigid pipe must be used.

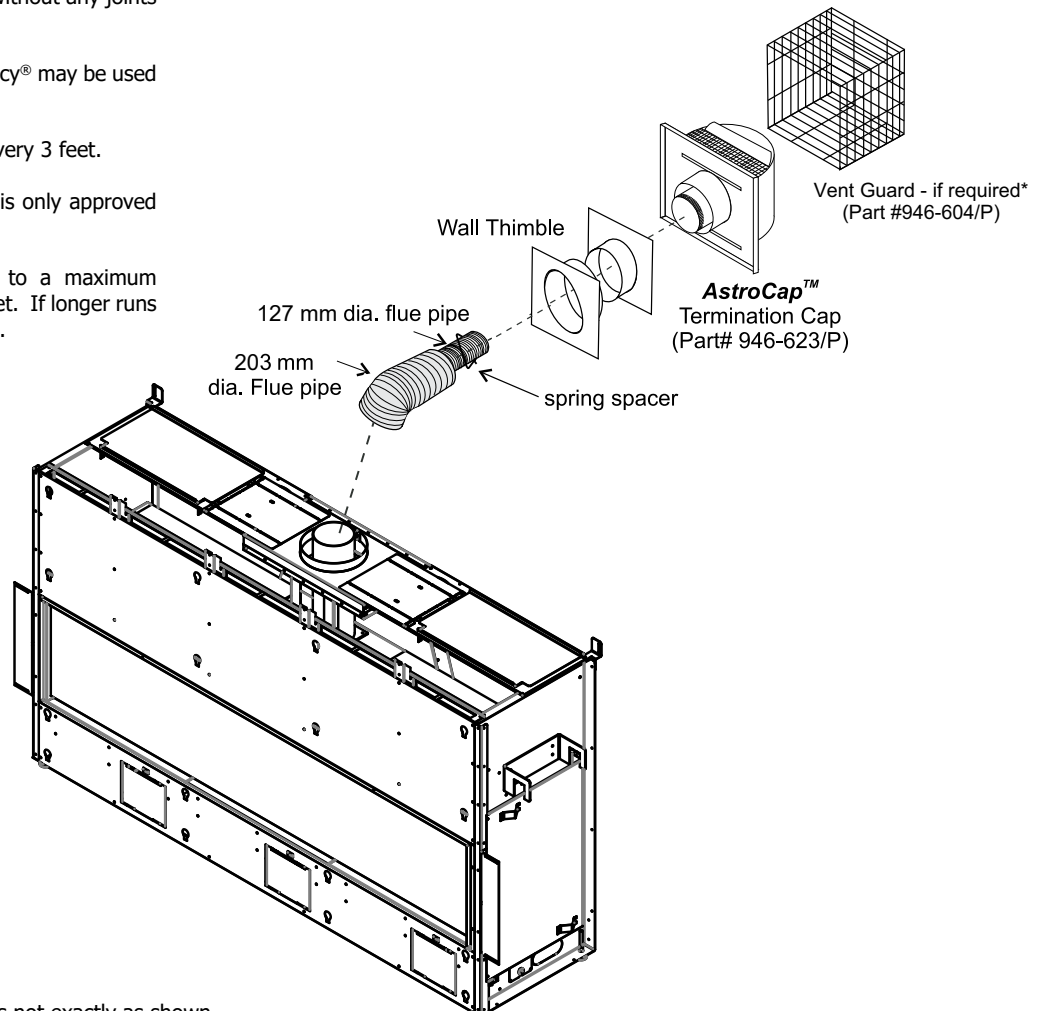

*Unit is not exactly as shown.

HORIZONTAL TERMINATIONS

Rigid Pipe 5" x 8"

The diagrams below show examples of horizontal termination arrangements using one, two, or three 90° elbows (two 45° elbows equal one 90° elbow).

1. A maximum of three 90° elbows are permitted.
 2. Minimum distance between elbows is 1 ft. (305mm).
- Maintain clearances to combustibles as listed in the "Clearances" section.
 - Horizontal vent must be supported every 3 feet.
 - Firestops are required at each floor level and whenever passing through a wall.
 - Must use optional rigid pipe adaptor (Part# 770-994) when using rigid pipe vent systems.
 - A vent guard should be used whenever the termination is lower than the specified minimum or as per local codes.
 - Flex system can only be used up to 10 feet - otherwise rigid venting must be used.

Horizontal Venting with Two (2) 90° Elbows

One 90° elbow = Two 45° elbows.

Option	V	H + H1	With these options, maximum total pipe length is 30 feet with minimum of 6 feet total vertical and maximum 8 feet total horizontal. Please note minimum 1 foot between 90° elbows is required.
A)	1' Min.	2' Max.	
B)	2' Min.	4' Max.	
C)	3' Min.	5' Max.	
D)	4' Min.	6' Max.	
E)	5' Min.	7' Max.	
F)	6' Min.	8' Max.	
Restrictor Set 0 - Factory Setting			

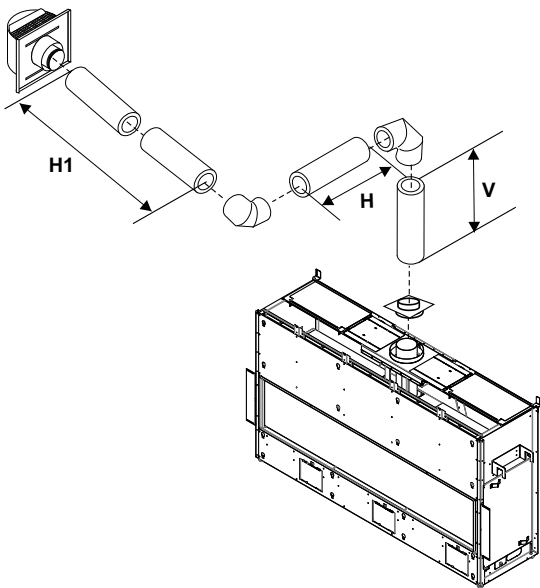

Horizontal Venting with Three (3) 90° Elbows

One 90° elbow = Two 45° elbows.

Option	V	H	V + V1	H + H1	With these options, max. total pipe length is 30 feet with min. of 12 feet total vertical and max. 9 feet total horizontal. Please note min. 1 foot between 90° elbows is required.
A)	1' Min.	1' Max.	2' Min.	2' Max.	
B)	1' Min.	2' Max.	3' Min.	3' Max.	
C)	2' Min.	2' Max.	5' Min.	4' Max.	
D)	3' Min.	2' Max.	7' Min.	5' Max.	
E)	4' Min.	3' Max.	9' Min.	6' Max.	
F)	5' Min.	4' Max.	10' Min.	7' Max.	
G)	6' Min.	5' Max.	11' Min.	8' Max.	
H)	7' Min.	6' Max.	12' Min.	9' Max.	
Restrictor Set 0 - Factory Setting					

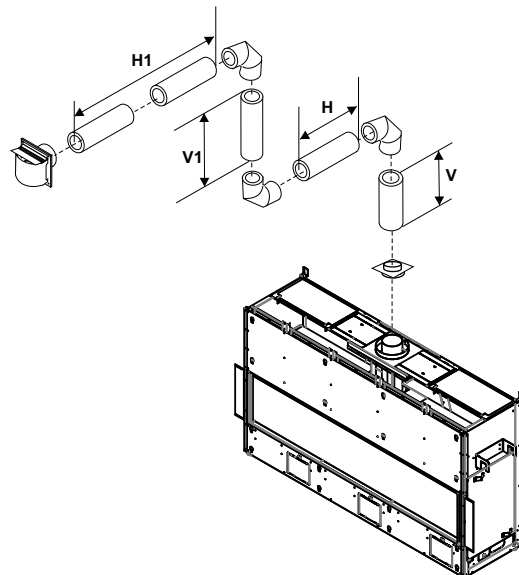

INSTALLATION WITH HORIZONTAL TERMINATION

Rigid Pipe- 5" x 8" Venting

The minimum components required for a basic horizontal termination are:

- 1 Horizontal Termination Cap
- 1 Rigid Pipe Adaptor (770-994)
- 1 Wall Thimble
- 1 Length of pipe to suit wall thickness (see chart)

Wall thickness is measured from the back standoffs to the inside mounting surface of termination cap. For siding other than vinyl furring strips may be used, instead of the vinyl siding standoff, to create a level surface to mount the vent terminal. The Terminal must not be recessed into siding. Measure the wall thickness including furring strips.

If a Vinyl Siding Standoff is required (it must be used with vinyl siding), measure to outside surface of wall without siding and add 2 inches.

Flat Wall Installation	
Wall Thickness (inches)	Vent Length Required (inches)
4" - 5-1/2"	6"
7" - 8-1/2"	9"
10" - 11-1/2"	12"
9" - 14-1/2"	11" - 14-5/8" Adj. Pipe
15" - 23-1/2"	17" - 24" Adj. Pipe

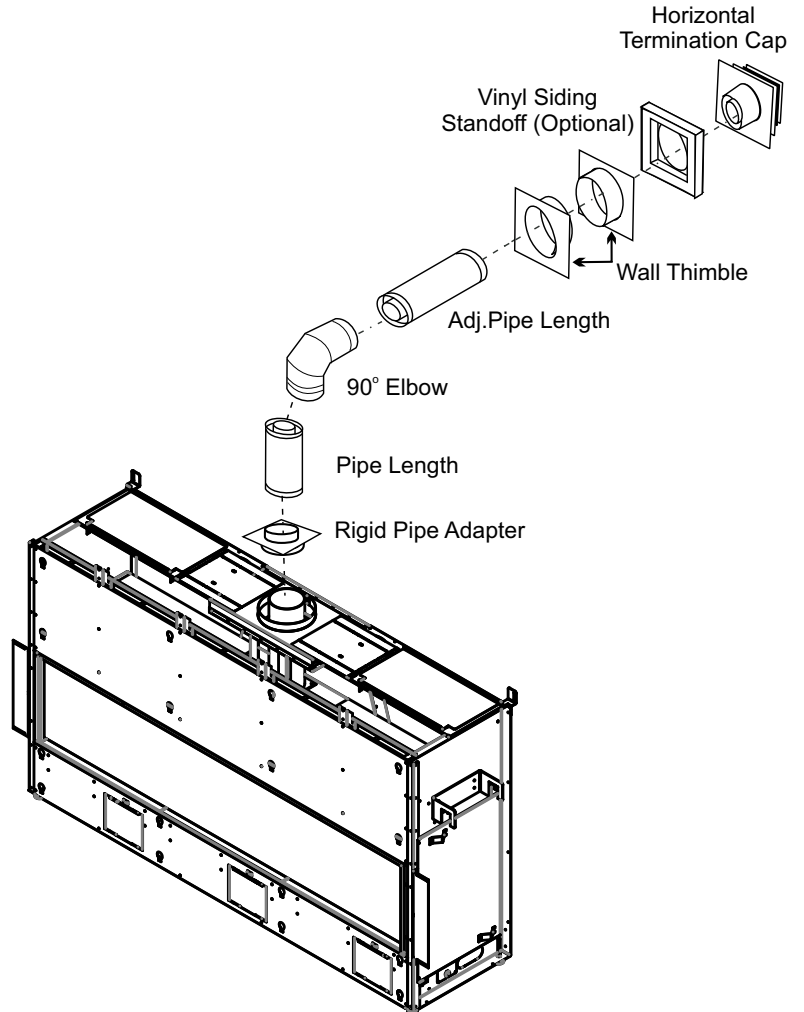

*Unit is not exactly as shown.

WARNING:

Do not combine venting components from different venting systems.

However use of the the AstroCap™ and FPI Riser is acceptable with all systems.

This product has been evaluated by Intertek for using a Rigid Pipe Adaptor in conjunction with DuraVent Direct-Vent, Selkirk Direct-Temp, Ameri Vent Direct Venting, ICC Excel Direct, Olympia Ventis DV, and Security Secure Vent systems. Use of these systems with the Rigid Pipe adaptor is deemed acceptable and does not affect the Intertek WHI listing of components.

When using Rigid Vent other than Simpson Dura-Vent, 3 screws must be used to secure rigid pipe to adaptor.

The FPI AstroCap™ and FPI Riser Vent terminal are certified for installations using FPI venting systems as well as Simpson Dura-Vent® Direct Vent, American Metal Products Ameri Vent Direct Vent, Security Secure Vent®, ICC Excel, Olympia Ventis DV, Selkirk Direct-Temp. AstroCap™ is a proprietary trademark of FPI Fireplace Products International Ltd. Dura-Vent® and Direct Vent are registered and/or proprietary trademarks of Simpson Dura-Vent Co. Inc.

Venting Introduction

The CV60E-1-1 uses the "balanced flue" technology Co-Axial system. The inner liner vents products of combustion to the outside while the outer liner draws outside combustion air into the combustion chamber thereby eliminating the need to use heated room air for combustion and losing warm room air up the chimney.

Note: These flue pipes must not be connected to any other appliance.

The gas appliance and vent system must be vented directly to the outside of the building, and never be attached to a chimney serving a separate solid fuel or gas burning appliance. Each direct vent gas appliance must use it's own separate vent system. Common vent systems are prohibited.

Venting Arrangement for Horizontal Terminations

The diagram shows all allowable combinations of vertical runs with horizontal terminations, using one 90° (two 45° elbows equal one 90° elbow).

Note: Must use optional rigid pipe adapter (Part# 770-994) when using Rigid Pipe Venting Systems)

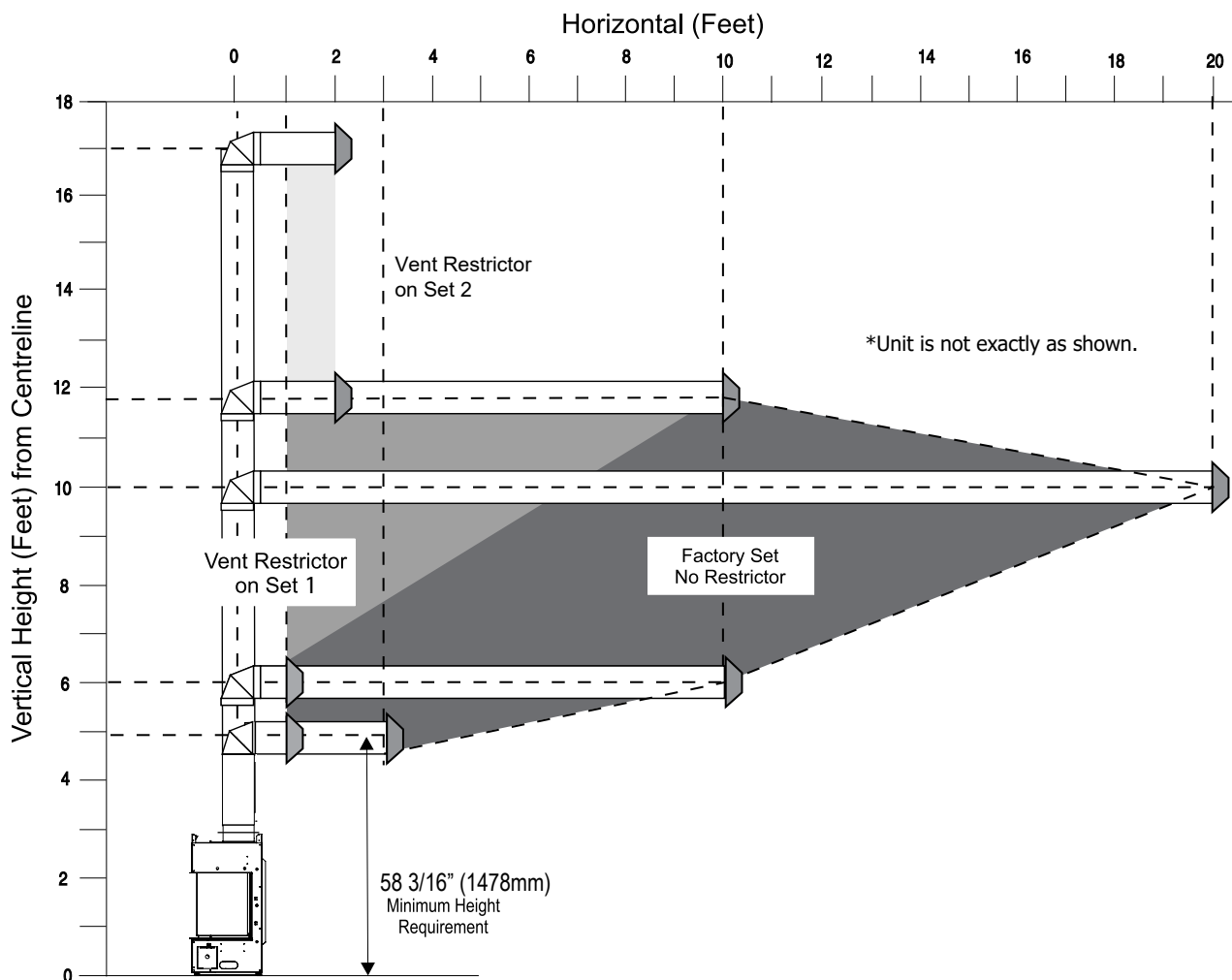

VENT RESTRICTOR SETTING:

Vent restrictor factory set at Set 0.

Refer to the "Vent Restrictor Position" section for details on how to change the vent restrictor from the factory setting of Set 0 to Set 2 if required.

Note: For horizontal terminations the Regency Direct Vent Flex System may be used for installations with a maximum continuous vent length of up to 10 feet. If longer runs are required, rigid pipe must be used.

- Maintain clearances to combustibles as listed in "Clearances" section
- Horizontal vent must be supported every 3 feet.
- Firestops are required at each floor level and whenever passing through a wall.
- A vent guard should be used whenever the termination is lower than the specified minimum or as per local codes.

Venting Arrangement for Vertical Terminations With Straight Vertical Venting and or With a Max. of Two 90° Elbows (1 - 90° = 2 - 45°)

The shaded area in the diagram shows all allowable combinations of straight vertical and offset to vertical terminations, using two 90° elbows, with rigid/flex pipe venting systems.

- Two 45° elbows equal to one 90° elbow.
- Vent must be supported at offsets.
- Minimum distance between elbows is 1 ft. (305mm).
- Maintain clearances to combustibles as listed in the "Clearances" section.
- Horizontal vent must be supported every 3 feet.
- Firestops are required at each floor level and whenever passing through a wall.
- Must use optional rigid pipe adaptor (Part# 770-994) when using rigid pipe vent systems.
- Refer to the "Vent Restrictor Position" section for details on how to change the vent restrictor from the factory setting of Set 0 through to Set 3 if required.

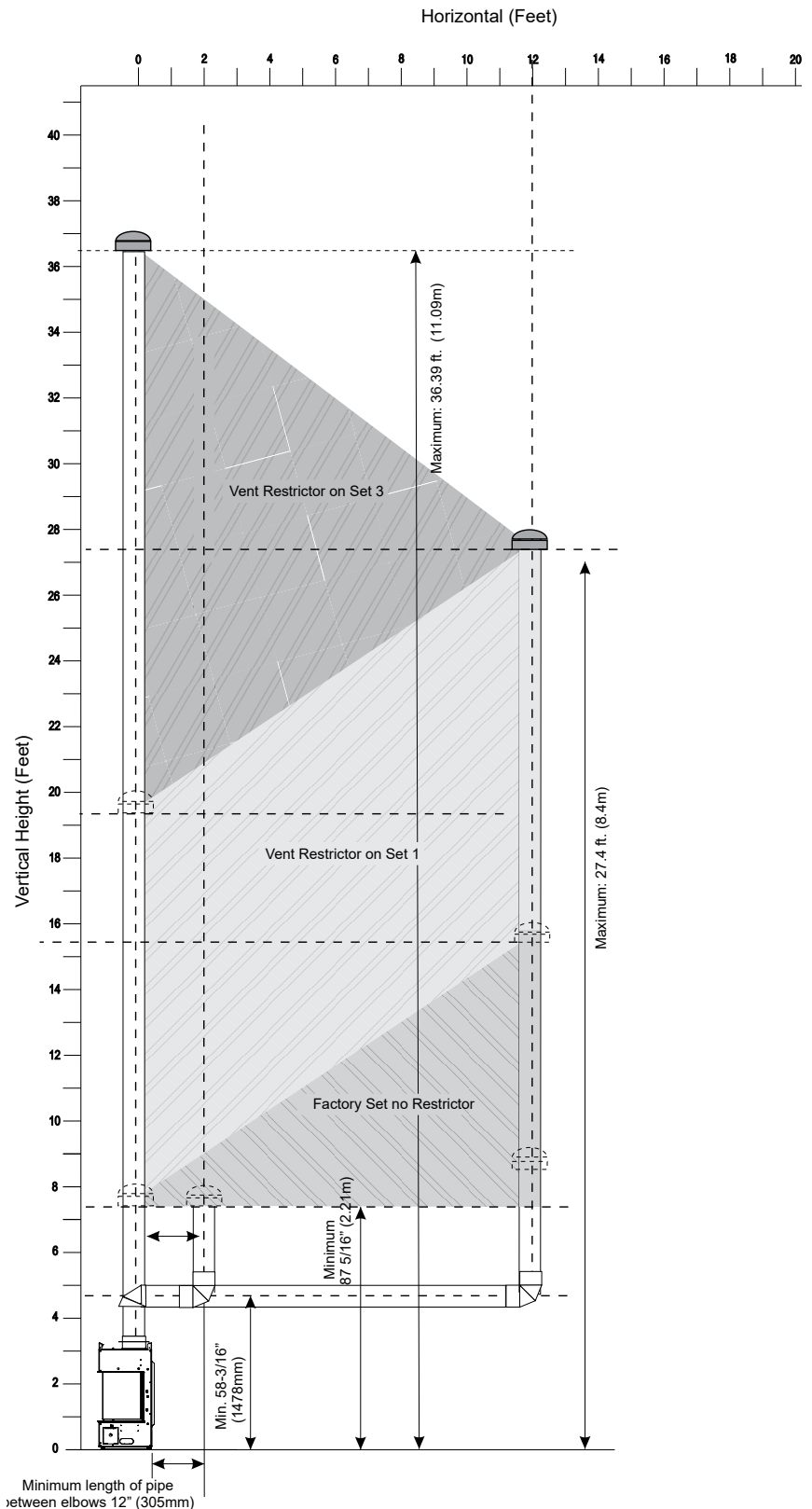

VERTICAL TERMINATIONS

Rigid Pipe 5" x 8"

The minimum components required for a basic vertical termination are:

- 1 Vertical Termination Cap
- 1 Rigid Pipe Adaptor (770-994)
- 1 Ceiling Firestop
- 1 Flashing
- 1 Storm Collar
- 1 Length of pipes to suit wall thickness & vent run (see chart)

Galvanized pipe is desirable above the roofline due to its higher corrosion resistance. Continue to add pipe sections through the flashing until the height of the vent cap meets the minimum height requirements specified in table below or local codes. Note that for steep roof pitches, the vertical height must be increased. A poor draft, or down drafting can result from high wind conditions near big trees or adjoining roof lines, in these cases, increasing the vent height may solve the problem.

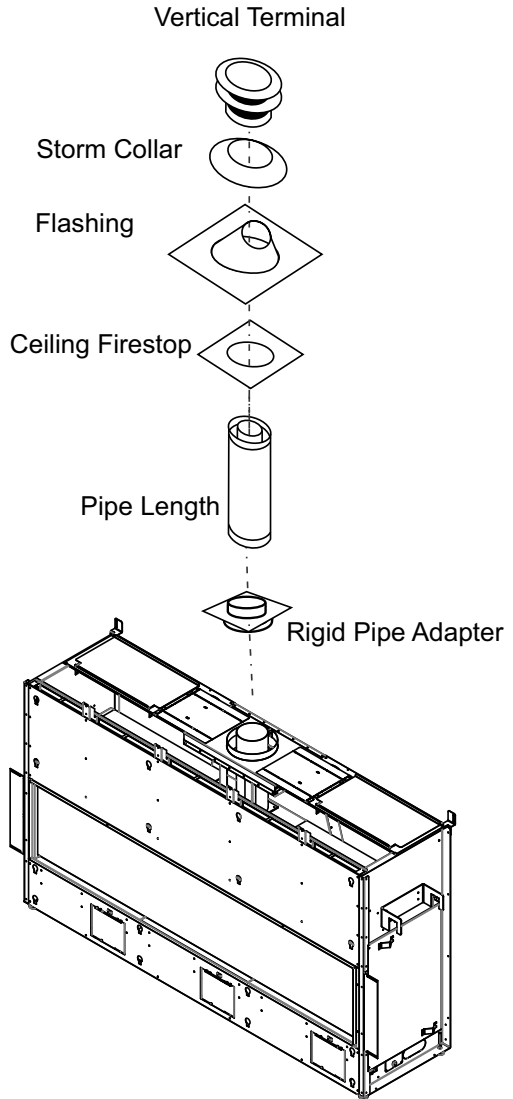

*Unit is not exactly as shown.

Roof Pitch	Minimum Vent Height	
	Feet	Meters
flat to 7/12	2	0.61
over 7/12 to 8/12	2	0.61
over 8/12 to 9/12	2	0.61
over 9/12 to 10/12	2.5	0.76
over 10/12 to 11/12	3.25	0.99
over 11/12 to 12/12	4	1.22
over 12/12 to 14/12	5	1.52
over 14/12 to 16/12	6	1.83
over 16/12 to 18/12	7	2.13
over 18/12 to 20/12	7.5	2.29
over 20/12 to 21/12	8	2.44

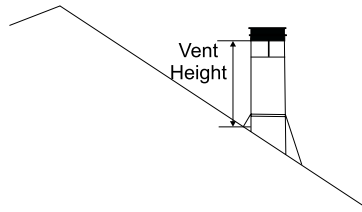

WARNING:

Do not combine venting components from different venting systems.

However use of the the AstroCap™ and FPI Riser is acceptable with all systems.

This product has been evaluated by Intertek for using a Rigid Pipe Adaptor in conjunction with Duravent Direct-Vent, Selkirk Direct-Temp, Ameri Vent Direct Venting, ICC Excel Direct, Olympia Ventis DV, and Security Secure Vent systems. Use of these systems with the Rigid Pipe adaptor is deemed acceptable and does not affect the Intertek WHI listing of components.

When using Rigid Vent other than Simpson Dura-Vent, 3 screws must be used to secure rigid pipe to adaptor.

The FPI AstroCap™ and FPI Riser Vent terminal are certified for installations using FPI venting systems as well as Simpson Dura-Vent® Direct Vent, American Metal Products Ameri Vent Direct Vent, Security Secure Vent®, ICC Excel, Olympia Ventis DV, Selkirk Direct-Temp. AstroCap™ is a proprietary trademark of FPI Fireplace Products International Ltd. Dura-Vent® and Direct Vent are registered and/or proprietary trademarks of Simpson Dura-Vent Co. Inc.

Vertical Terminations Rigid/Flex Pipe 5" x 8"

- Two 45° elbows equal to one 90° elbow. Maximum of six 45° elbows allowed.
- Vent must be supported at offsets.
- Minimum distance between elbows is 1 ft. (305mm).
- Maintain clearances to combustibles as listed in the "Clearances" section.
- Horizontal vent must be supported every 3 feet.
- Firestops are required at each floor level and whenever passing through a wall.
- Must use optional rigid pipe adaptor (Part# 770-994) when using rigid pipe vent systems

Vertical Venting with Three (3) 90° Elbows

One 90° elbow = Two 45° elbows.

Option	V	H + H1	V + V1	With these options, max. total pipe length is 30 feet with min. of 10 feet total vertical and max. 8 feet total horizontal. Please note min. 1 foot between 90° elbows is required.
A)	1' Min.	2' Max	3' Min.	
B)	2' Min.	3' Max	4' Min.	
C)	3' Min.	4' Max	6' Min.	
D)	4' Min.	5' Max	7' Min.	
E)	5' Min.	6' Max	8' Min.	
F)	6' Min.	7' Max	9' Min.	
G)	7' Min.	8' Max	10' Min.	

Lengths do not include elbow indicated
Restrictor Set 0 - Factory Setting

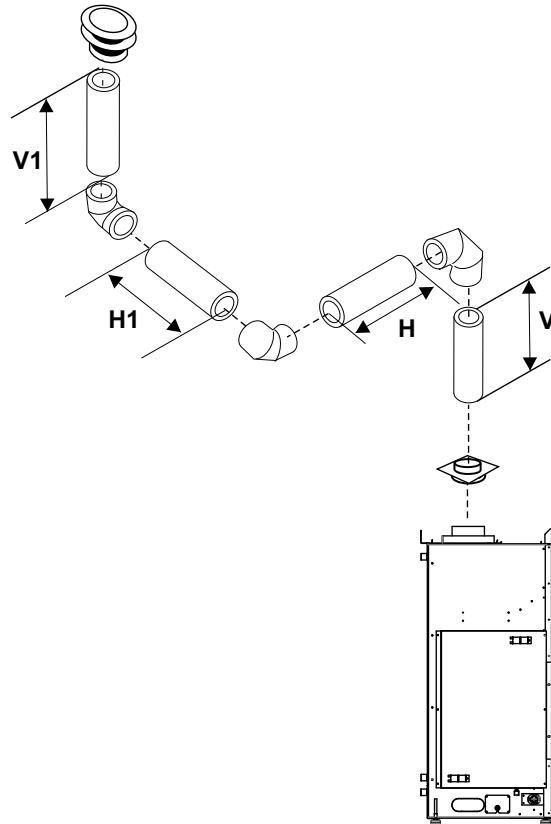

Horizontal Terminations - Inline Horizontal Vent Chart Inline Power Vent Kit #666-945

NOTES

- Rigid pipe is approved for up to 72 feet (21.95 m).
- Flex pipe is approved for up to 40 feet (12.19 m) using 2 X 946-756-- 20 foot (6.10 m) flex kits.

The gas power vent system is designed to allow the installation of a gas appliance when typical vent configurations (Non-Power Vent Direct Vent Systems With no Fan Assist) are not possible.

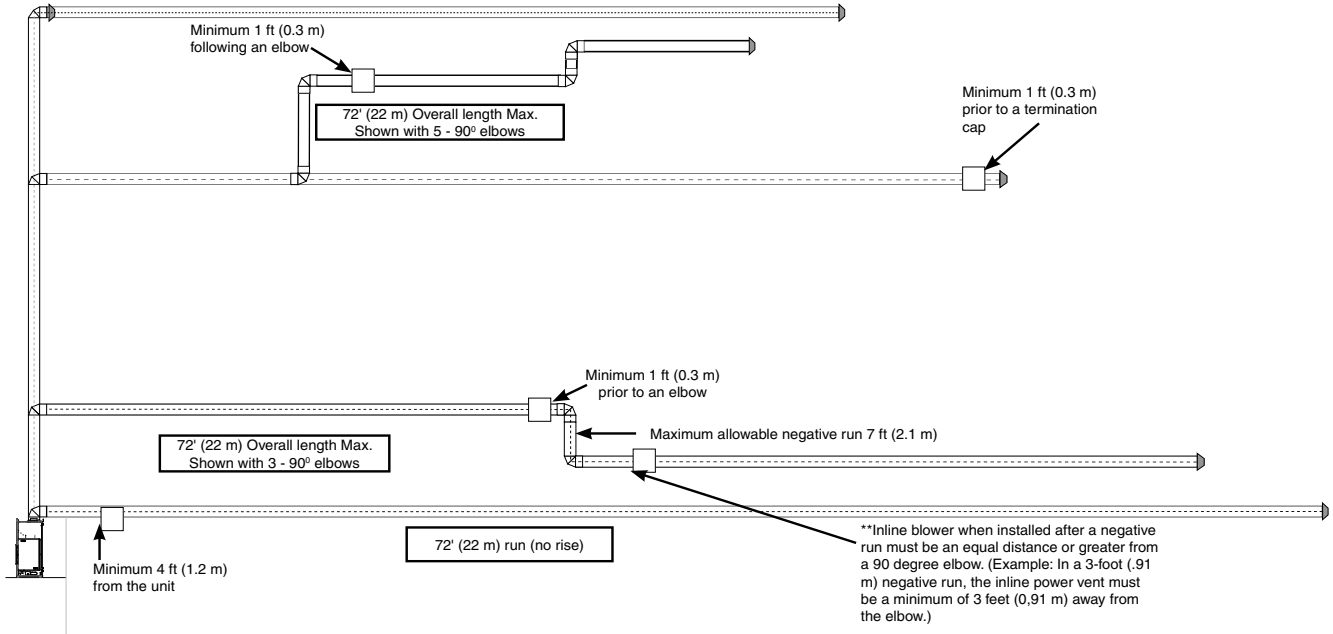

IMPORTANT

- **Maximum total vent length (based on overall length of combined chimney components) = 72' (22 m)**
- **Maximum total negative vent length = 7' (2.1 m).**
- **Do not run positive venting after a negative run.**
- **Maximum of six - 90° elbows permitted.**
- **One 90° elbow = two 45° elbows.**
- **Minimum 4' (1.2 m) from the unit prior to terminating.**

Inline power vent location restrictions:

- Minimum 4 ft (1.2 m) from the unit
- Minimum 1 ft (0.3 m) prior to an elbow.
- Minimum 1 ft (0.3 m) following an elbow.
- Minimum 1 ft (0.3 m) prior to a termination cap.
- When the inline blower is installed after a negative run, for every foot of negative run the inline blower must be an equal distance or greater from the 90-degree elbow. See example above.

Horizontal Terminations - End of Line Horizontal Vent Chart End of Line Power Vent Kit #946-535

NOTES

- Rigid pipe is approved for up to 72 feet (21.95 m).
- Flex pipe is approved for up to 40 feet (12.19 m) using 2 X 946-756-- 20 foot (6.10 m) flex kits.

The gas power vent system is designed to allow the installation of a gas appliance when typical vent configurations (Non-Power Vent Direct Vent Systems With no Fan Assist) are not possible.

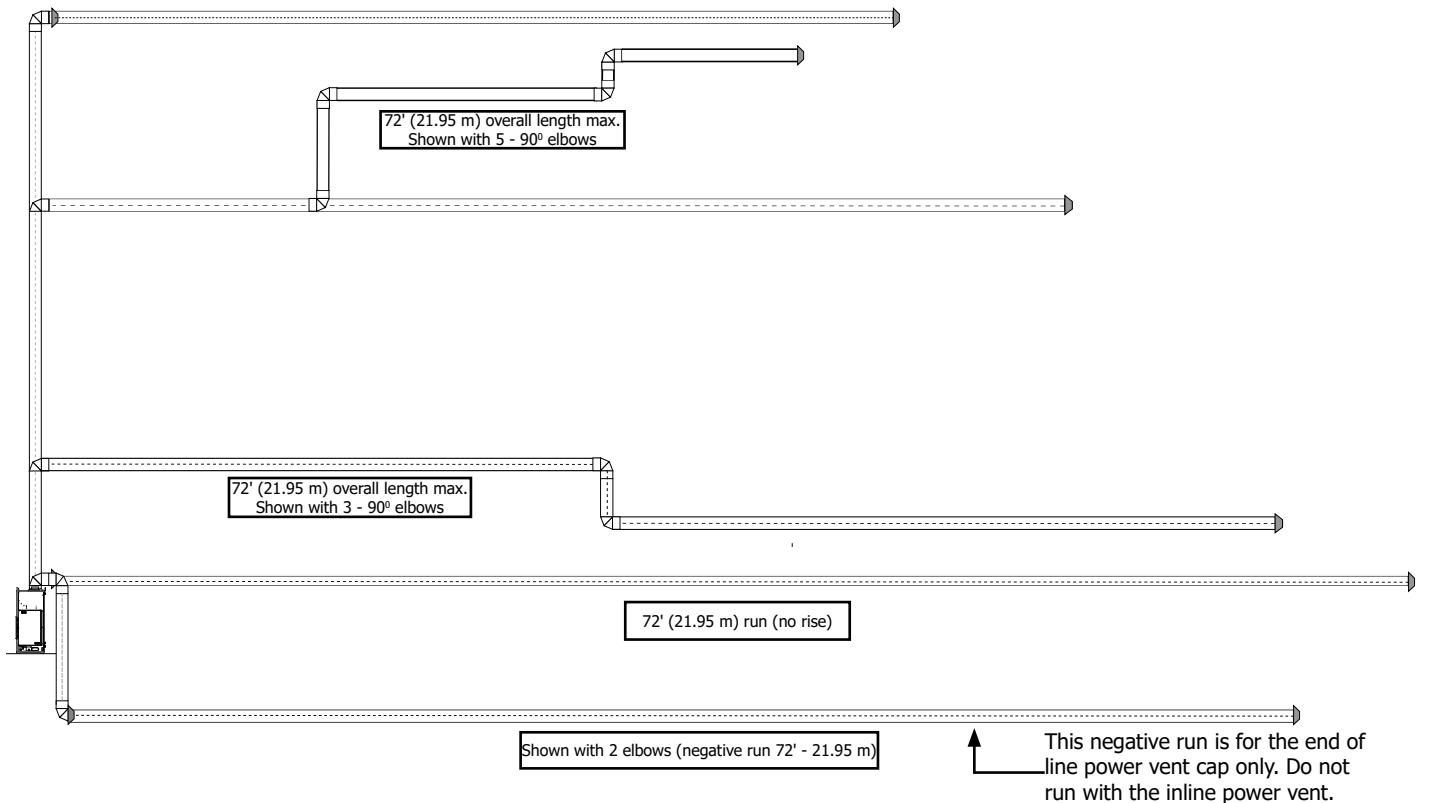

IMPORTANT

- **Maximum total vent length (based on overall length of combined chimney components) = 72' (21.95 m)**
- **Maximum total negative vent length = 7' (2.1 m).**
- **Do not run positive venting after a negative run.**
- **Maximum of six - 90° elbows permitted.**
- **One 90° elbow = two 45° elbows.**
- **Minimum 4' (1.2 m) from the unit prior to terminating.**

Venting Arrangement for Vertical Terminations Inline Power Vent

Vertical venting with straight vertical venting and or with a max. of six (6) 90° Elbows (1 - 90° = 2 - 45°)

- NOTES**
- Rigid pipe is approved for up to 72 feet (22 m).
 - Flex pipe is approved for up to 40 feet (12.2 m) using two 20 foot (6.1 m) flex kits (part # 946-756).

- Two 45° elbows equal to one 90° elbow.
- Vent must be supported at offsets.
- Minimum distance between elbows is 1 ft. (0.3 m).
- Maintain clearances to combustibles as listed in the "Clearances" section.
- Horizontal vent must be supported every 3 feet (0.91 m).
- Firestops are required at each floor level and whenever passing through a wall.

Restrictor set on 0 (fully open) regardless of vent run.

- Inline power vent location restrictions:**
- Minimum 4 ft (1.2 m) from the unit.
 - Minimum 1 ft (0.3 m) prior to an elbow.
 - Minimum 1 ft (0.3 m) following an elbow.
 - Minimum 2 ft (0.6 m) prior to a termination cap.
 - Minimum 2 ft. from inline PV to termination cap.
 - Minimum 4' from top of unit to inline PV.
 - Max. of 72' (22 m), using up to six 90° elbows (Example shows two 90° elbows).
 - No negative runs.

- NOTE**
- The inline power vent must be installed within the confines of the home/structure.

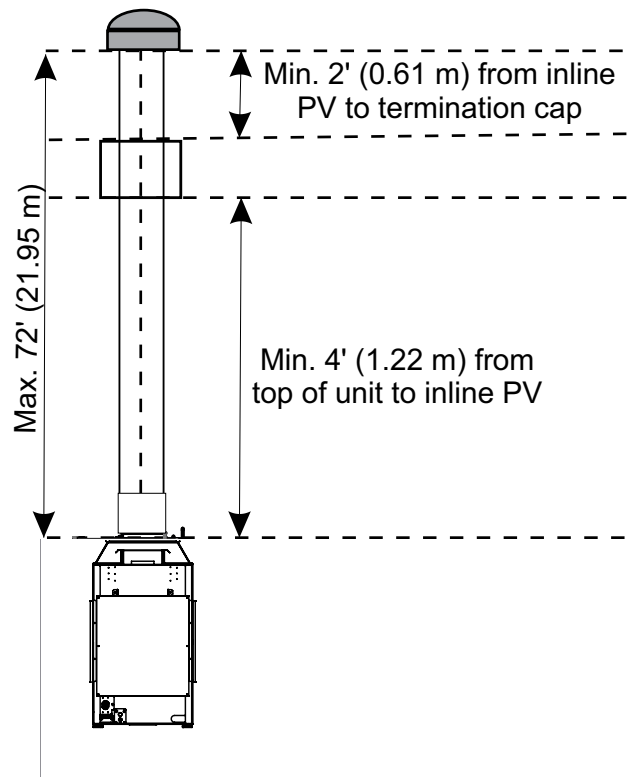

Max. of 72' (21.95 m), using up to six 90° elbows
(Note: two 90° elbows shown.)

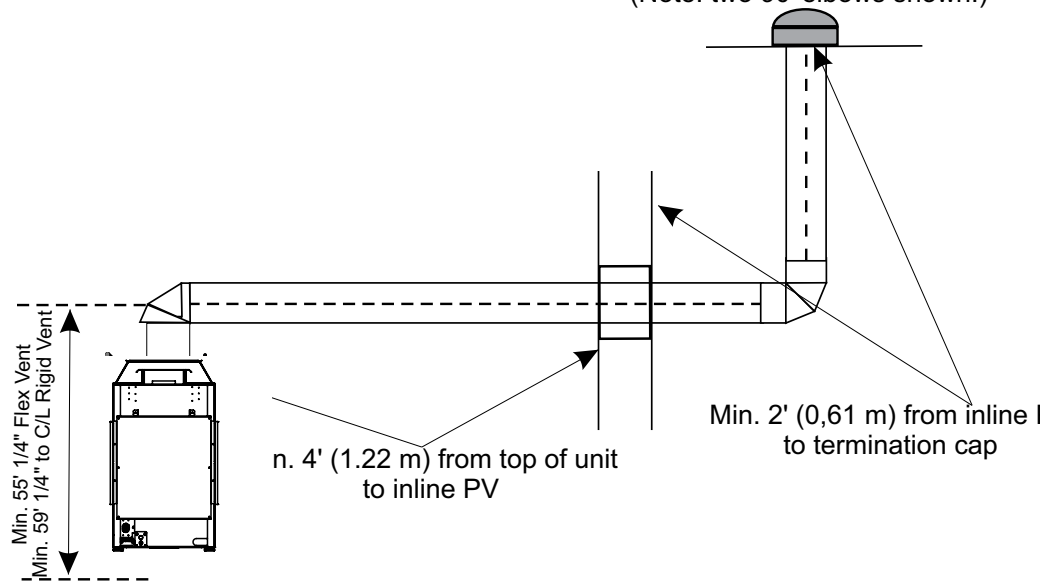

CHASE VENT INSTALLATION

Framed Opening must be between 3" and 3.5" tall, and at least 60.25" wide to accommodate the Chase vent.
 The top of the chase vent opening must be 2" or less from the top of the chase enclosure.

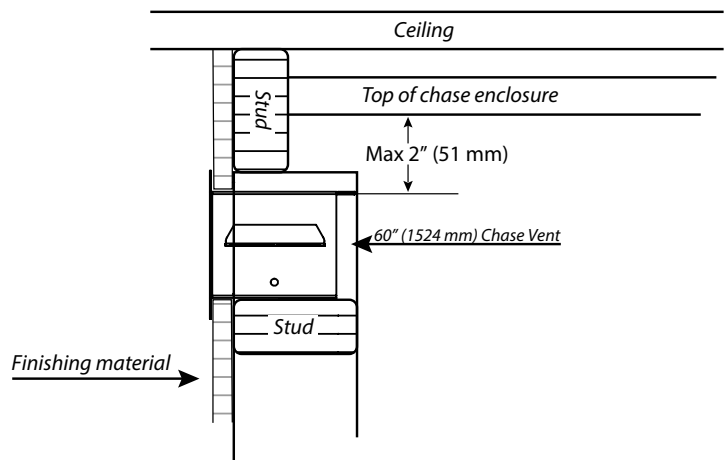
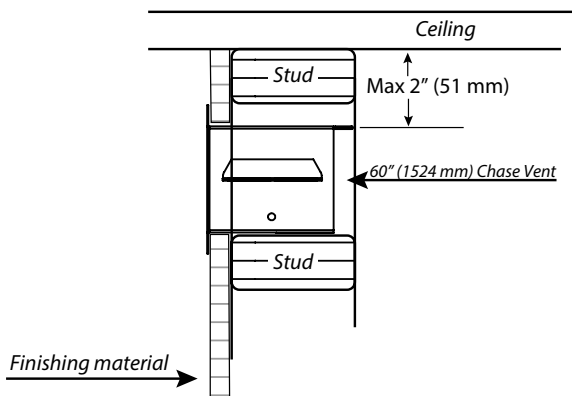
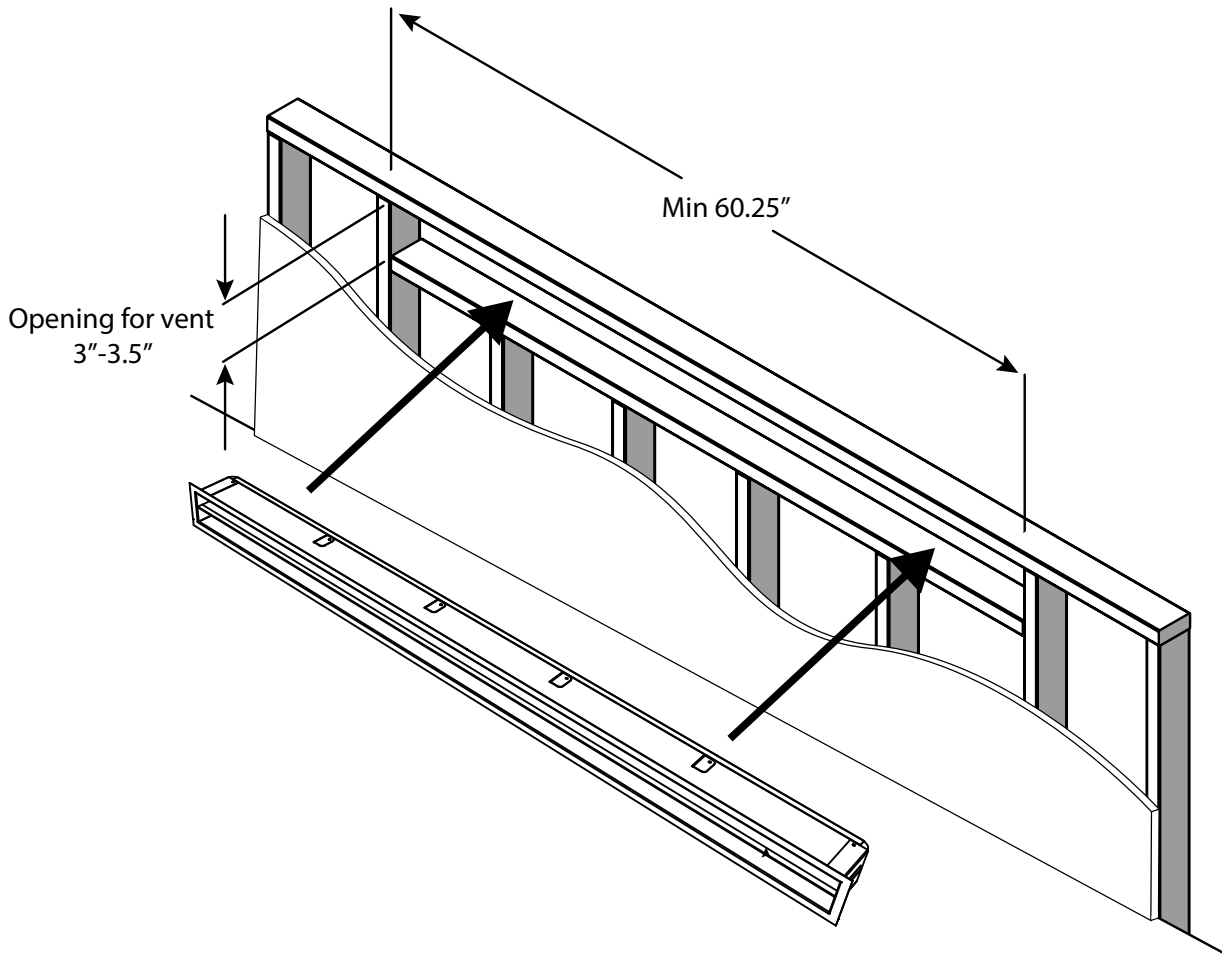

TYPICAL INSTALLATIONS

Flush Install

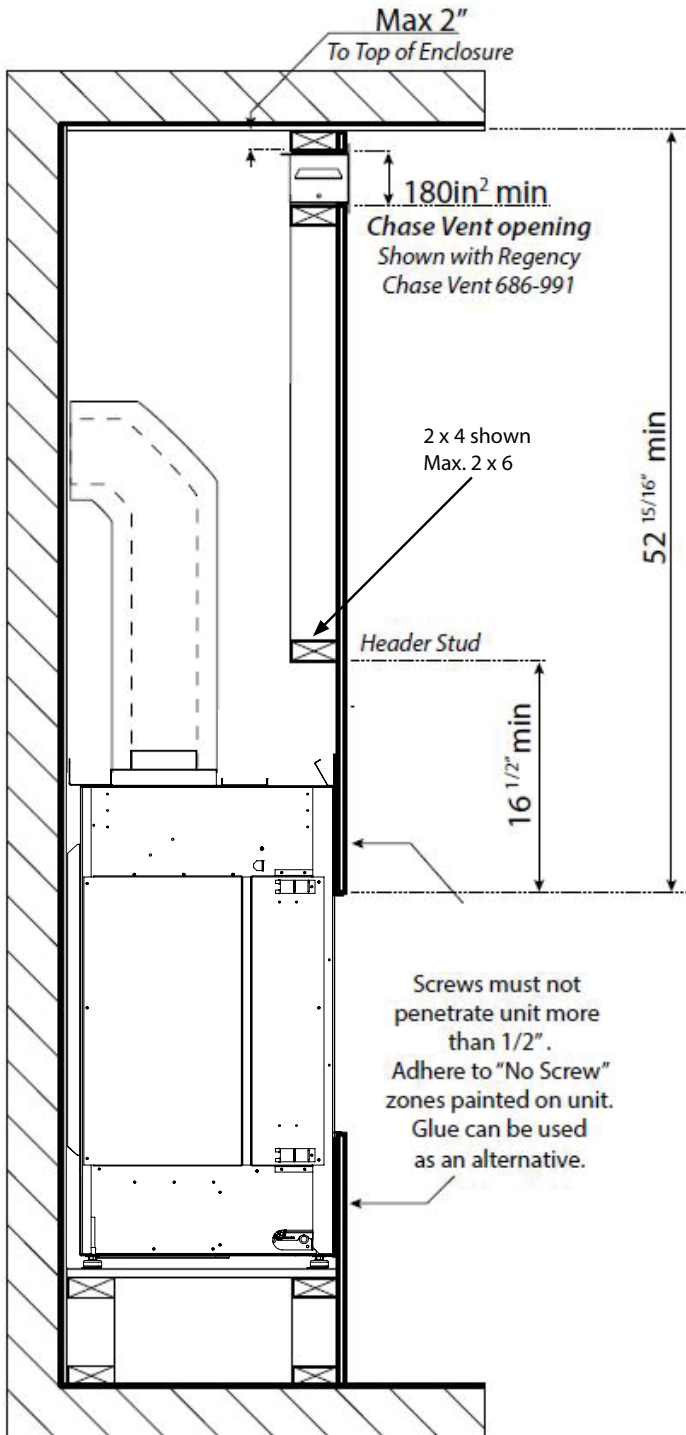

Recessed Install

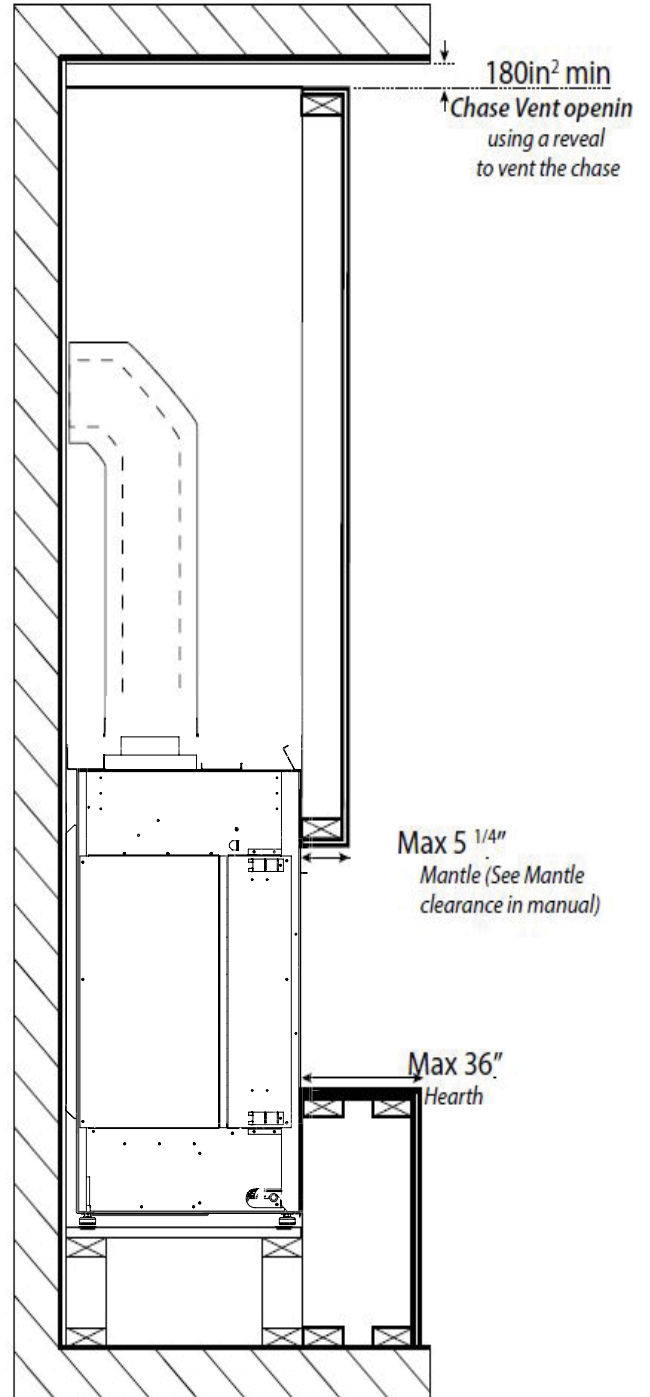

TYPICAL INSTALLATIONS

Maximum TV Recess

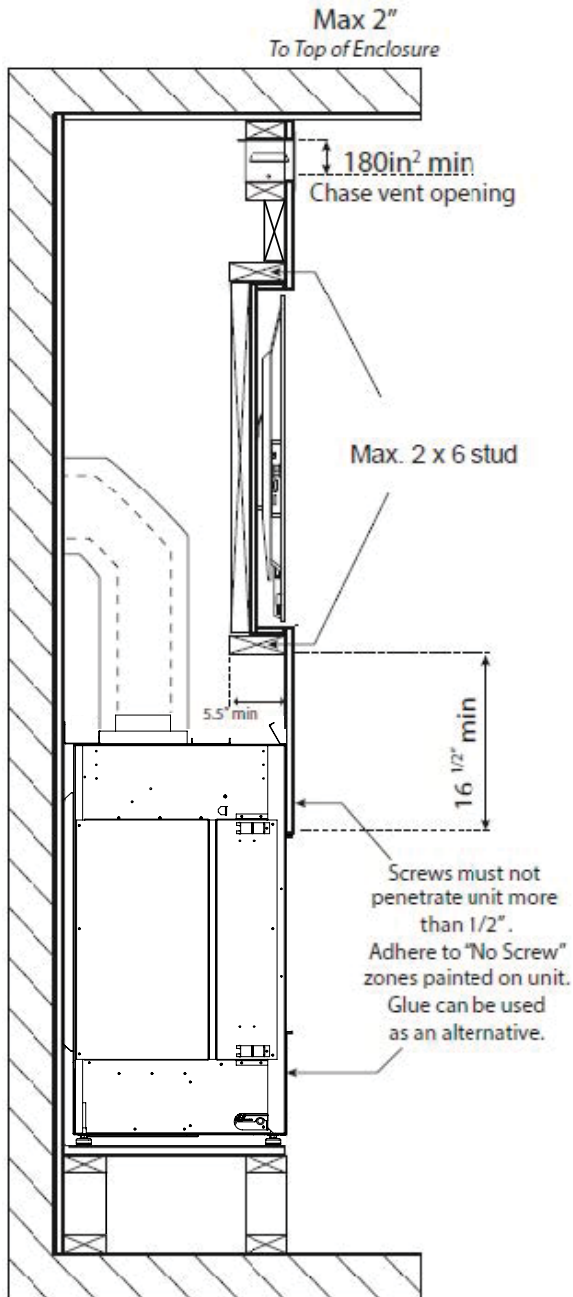

Flush TV with Hearth

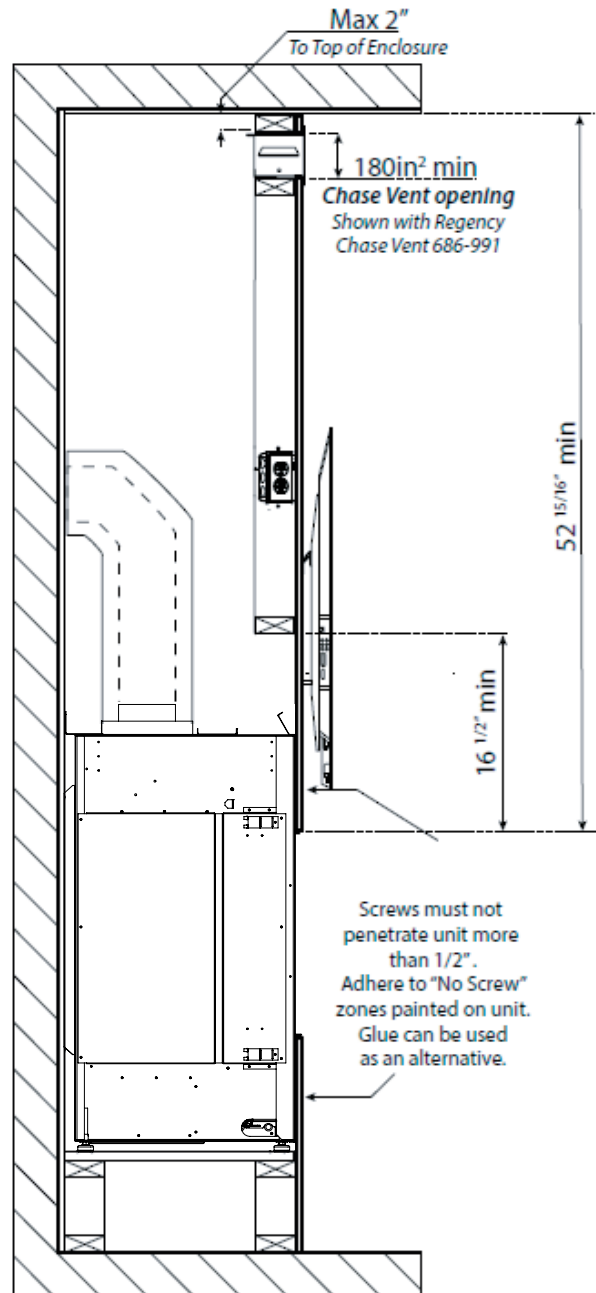

Note: The TV mounting bracket cannot be secured directly to the appliance. It must be secured to framing. The TV depicted in the picture may need to be higher depending on the style of TV mounting bracket used.

Unit Installation with Horizontal Termination 5" x 8" Venting (Rigid Vent Systems) (Non Power Vent)

Minimum Vent Clearances to Combustibles

* Clearances noted below must be maintained; except when passing through a wall, ceiling or at the termination where the use of a firestop or wall thimble reduces clearance to 1-1/2" (38mm).

Horizontal Top*	3" (76mm)*
Horizontal Side	2" (51mm)
Horizontal Bottom	2" (51mm)
Vertical Vent	2" (51mm)

Below are the recommended framing dimensions (inside measurements) for the 5" x 8" rigid vent terminations - for use with a firestop or wall thimble.

Install the vent system according to the manufacturer's instructions included with the components.

1. Set the unit in its desired location. Check to determine if wall studs or roof rafters are in the way when the venting system is attached. If this is the case, you may want to adjust the location of the unit. Rough in the gas preferably on the right side of the unit and the electrical (junction block is on the left side) on the left.
2. Direct Vent pipe and fittings are designed with special twist-lock connections to connect the venting system to the appliance flue outlet. A twist-lock appliance adaptor is required.
3. In conjunction with the Approved Vent system, install the adaptor after the unit is set in its desired location. Slip the adapter over the existing inner and outer flue collar. Fasten to the outer collar only with the 3 supplied screws (drilling pilot holes will make this easier).
4. Level the fireplace and fasten it to the framing using nails or screws through the top and side nailing strips.

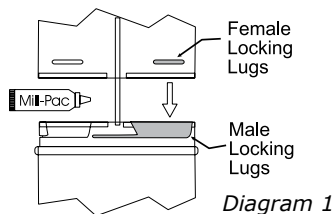

Diagram 1

5. Assemble the desired combination of pipe and elbows to the appliance adaptor and twist-lock for a solid connection.

Note: For best results and optimum performance with each approved venting system, it is highly recommended to apply "Mill-Pac" sealant (supplied) to every inner pipe connection. Failure to do so may result in drafting or performance issues not covered under warranty.

Horizontal runs of vent must be supported every 3 feet (0.9meter). Wall straps are available for this purpose.

6. Mark the wall for a square hole.-see chart to left for size. The center of the square hole should line up with the center-line of the horizontal pipe. Cut and frame the square hole in the exterior wall where the vent will be terminated. See diagram 2 for center line requirements.

If the wall being penetrated is constructed of non-combustible material, i.e. masonry block or concrete, an 8" (203mm) diameter hole is acceptable.

Notes:

- a) The horizontal run of vent must be level, or have a 1/4 inch rise for every 1 foot of run towards the termination. Never allow the vent to run downward. This could cause high temperatures and may present the possibility of a fire.
- b) The location of the horizontal vent termination on an exterior wall must meet all local and national building codes, and must not be blocked or obstructed. See "Exterior Vent Termination Locations" section for more details.

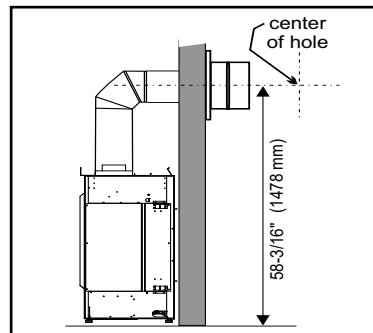

Diagram 1

c) Snorkel Terminations:

For installations requiring a vertical rise on the exterior of the building, 14-inch and 36-inch tall Snorkel Terminations are available, as well as the standard Riser Vent. Follow the same installation procedures as used for standard Horizontal Termination. NEVER install the snorkel upside down.

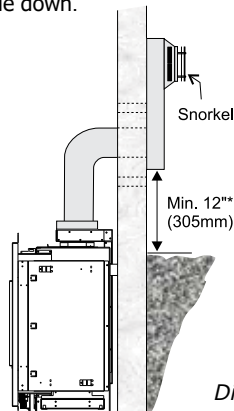

Diagram 2

*As specified in CSA B149.1 Installation Code. Local codes or regulations may require different clearances.

Below Grade Snorkel Installation

If the snorkel termination must be installed below grade, i.e. basement application, proper drainage must be provided to prevent water from entering the snorkel termination. See diagram 56. Do not attempt to enclose the snorkel within the wall or any other type of enclosure.

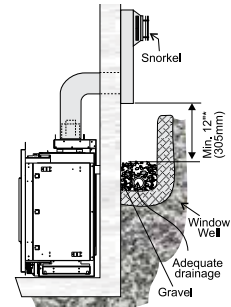

Diagram 4

7. Ensure that the pipe clearances to combustible materials are maintained (Diagram 55). Install the termination cap.

Note: If installing termination on a vinyl siding covered wall, a vinyl siding standoff or furring strips must be used to ensure that the termination is not recessed into the siding.

The four wood screws provided should be

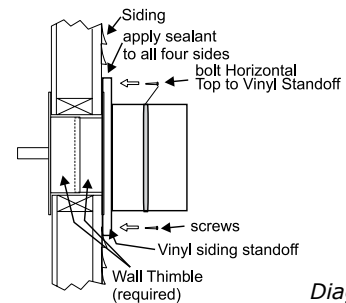

Diagram 5

replaced with appropriate fasteners for stucco, brick, concrete, or other types of sidings.

8. Before connecting the horizontal run of vent pipe to the vent termination, slide the Wall Thimble over the vent pipe. The wall thimble is required for all horizontal terminations.
9. Slide the appliance and vent assembly towards the wall carefully inserting the vent pipe into the vent cap assembly. It is important that the vent pipe extends into the vent cap sufficient distance so as to result in a minimum pipe overlap of 1-1/4 inches (32mm). Secure the connection between the vent pipe and the vent cap.
10. Install wall thimble in the center of the framed hole and attach with wood screws.

