

E33 Gas Insert

Model	E33-NG10	E33-LP10
Fuel Type	Natural Gas	Propane
Minimum Supply Pressure	5" W.C. (1.25 kPa)	12" W.C. (2.99 kPa)
Manifold Pressure - High	3.8" W.C. (0.95 kPa)	11" W.C. (2.74 kPa)
Manifold Pressure - Low	1.1" W.C. (0.27 kPa)	2.9" W.C. (0.72 kPa)
Orifice Size -Altitude 0-4500 ft.	#31 DMS	#50 DMS
Minimum Input Altitude 0-4500 ft. (0-1372m)	20,000 BTU/h (5.86 kW)	19,000 BTU/h (5.57 kW)
Maximum Input Altitude 0-4500 ft. (0-1372m)	38,000 BTU/h (11.14 kW)	35,500 BTU/h (10.40 kW)
Vent Sizing	3" Co-linear	3" Co-linear

Approved Venting Systems	
Flex Vent Systems:	FPI AstroCap™ Flex Vent
Alternate Approved Caps	
46DVA-VC Vertical Termination Cap	
46DVA-VCH High Wind Vertical Termination Cap	
46DVA-GK 3" Co-Linear adaptor with flashing	



In areas of consistently high winds, we recommend using the Simpson Dura-Vent System 46DVA-GK adaptor and 46DVA-VCH high-wind cap. The Air Intake pipe must be attached to the inlet air collar of the termination cap.

UNIT DIMENSIONS (WITH LOW PROFILE FACEPLATE)

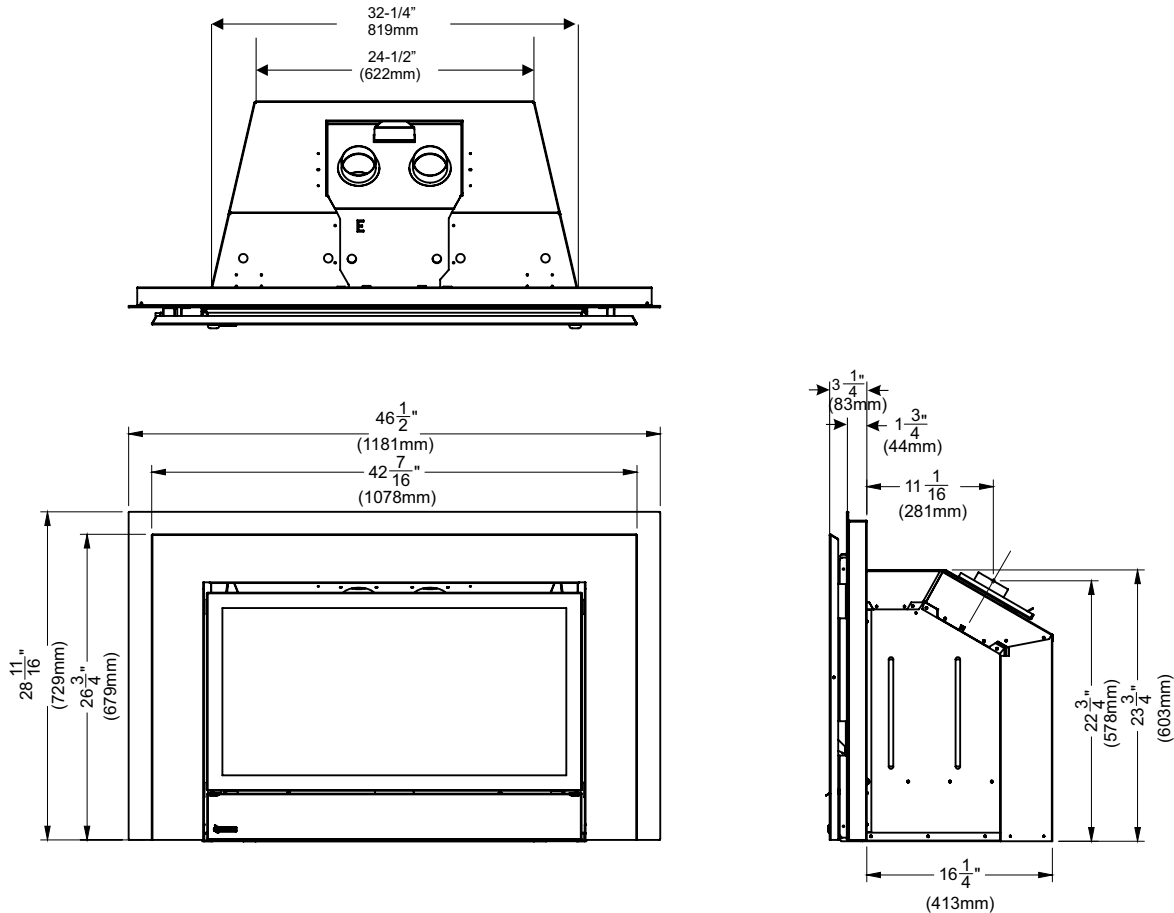

UNIT DIMENSIONS
OPTIONAL VIGNETTE FACEPLATE WITH SPACER

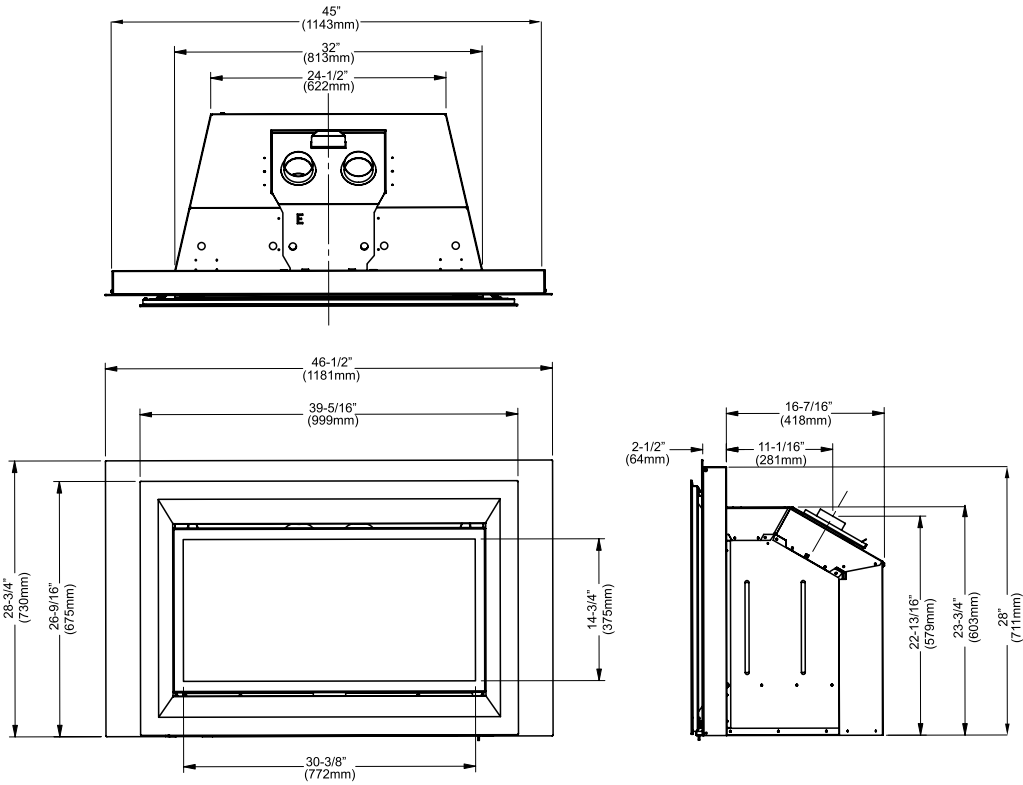

UNIT DIMENSIONS
OPTIONAL VIGNETTE FACEPLATE WITHOUT SPACER

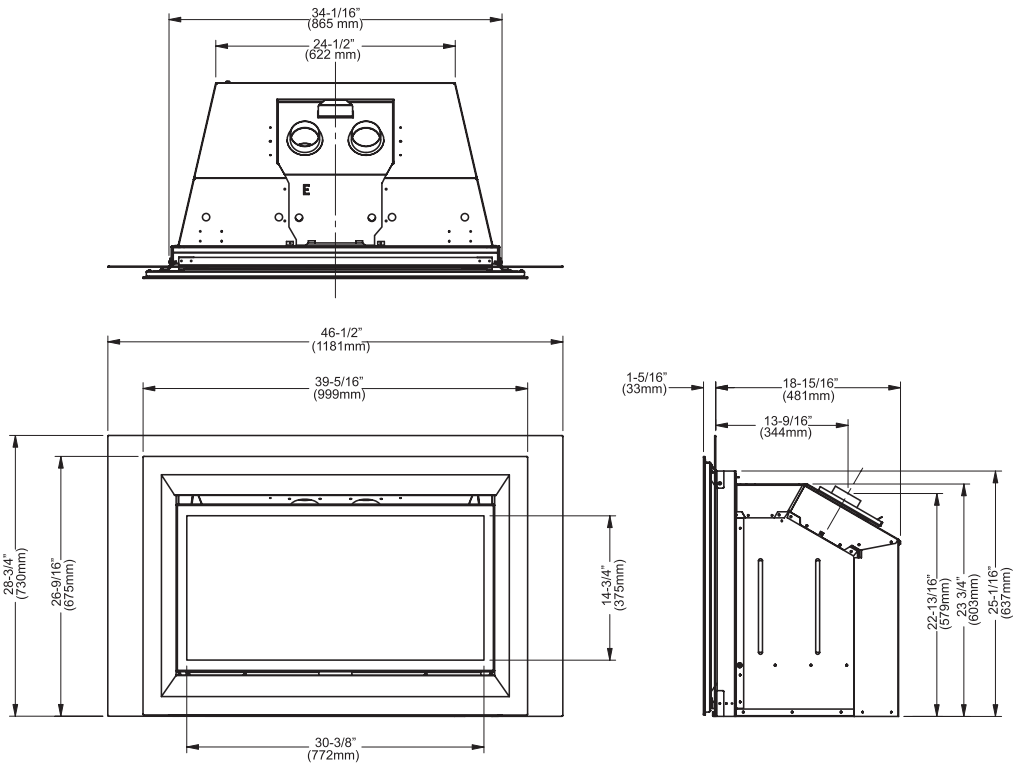

**UNIT DIMENSIONS
OVERSIZE BACKINGPLATE WITH SPACER**

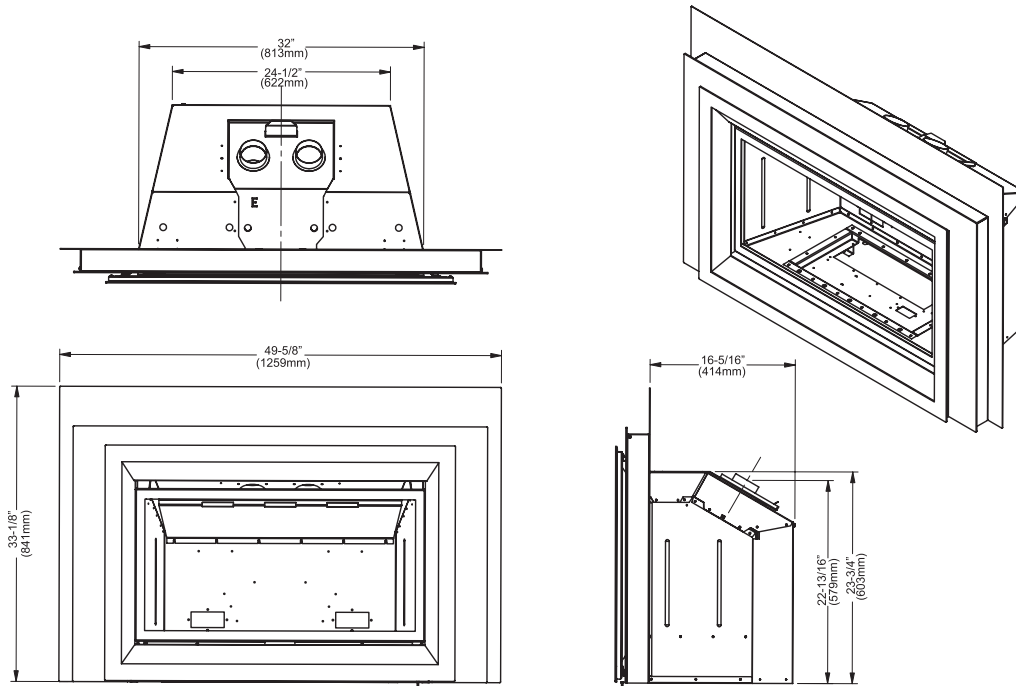

**UNIT DIMENSIONS
OPTIONAL 4 SIDED VIGNETTE FACEPLATE**

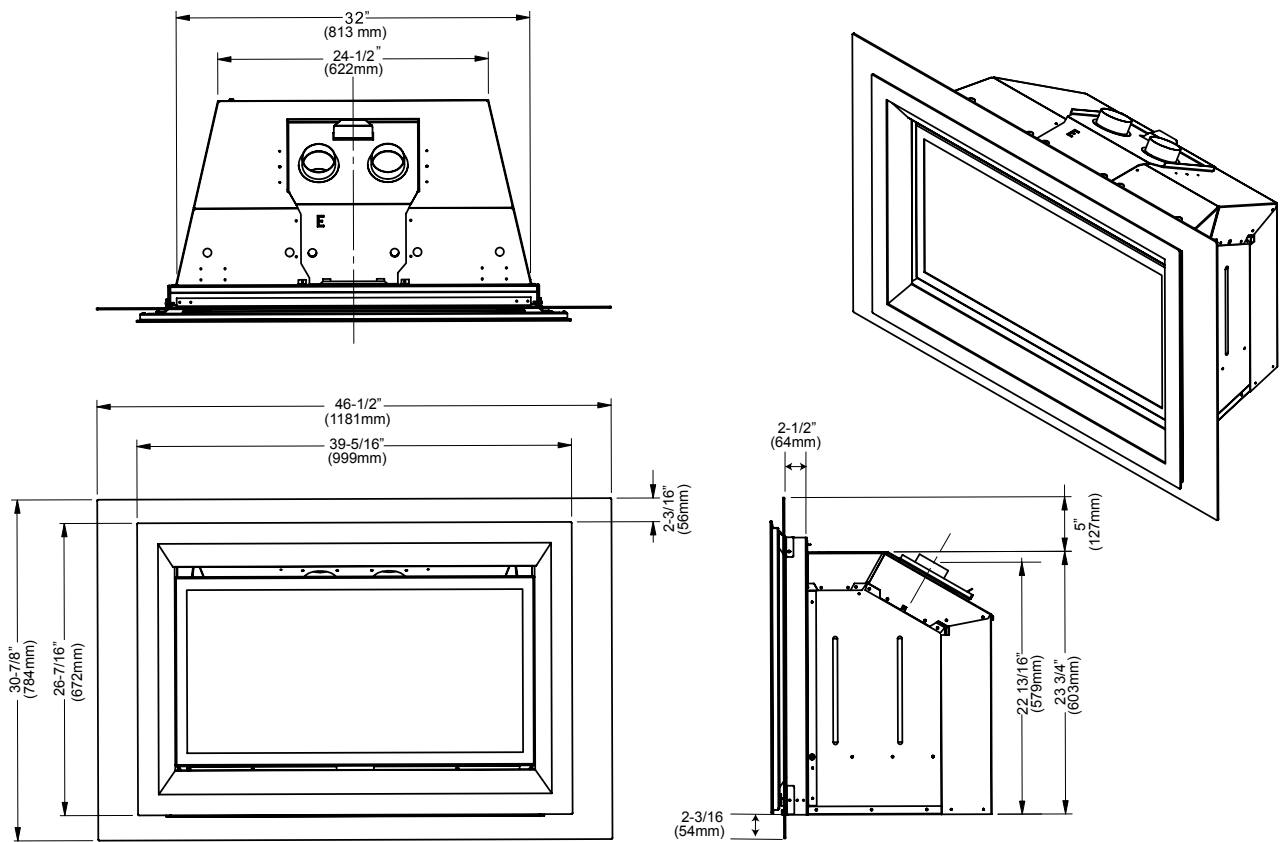

MINIMUM FIREPLACE DIMENSIONS

The minimum fireplace dimensions for the Regency gas fireplace insert are shown in the following diagrams:

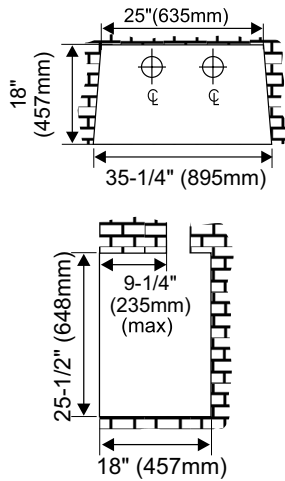

CLEARANCES

Unless otherwise stated the clearances listed below are Minimum distances to combustible materials. **Please Note: A major cause of chimney related fires is due to a failure to maintain required clearances (air space) to combustible materials. It is of the greatest importance that this fireplace and vent system be installed only in accordance with these instructions.**

	From Unit	
Side Walls	* A 8" (203 mm)	
Ceiling	B 47" (1194 mm)	
Min. Mantel Height	C 15" (381 mm)	
Max. Mantel Depth	D 12" (305 mm)	
Alcove Width	E 76" (1930 mm)	
Alcove Depth	F 36" (914 mm)	
Hearth Height	G 1-1/4" (32 mm)	
Hearth Width	H 45-1/2" (1156 mm)	
Hearth Depth	I 13" (330 mm)	

* Alcove side wall must have a min. of 8" clearance on one side.

* Measured from edge of glass frame.

(J) Glass Frame Width (Reference Only): 33-1/2" (851mm)

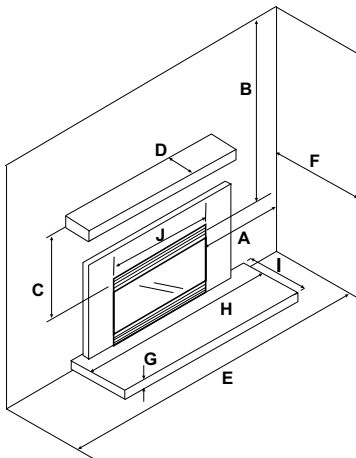

COMBUSTIBLE MANTEL CLEARANCES

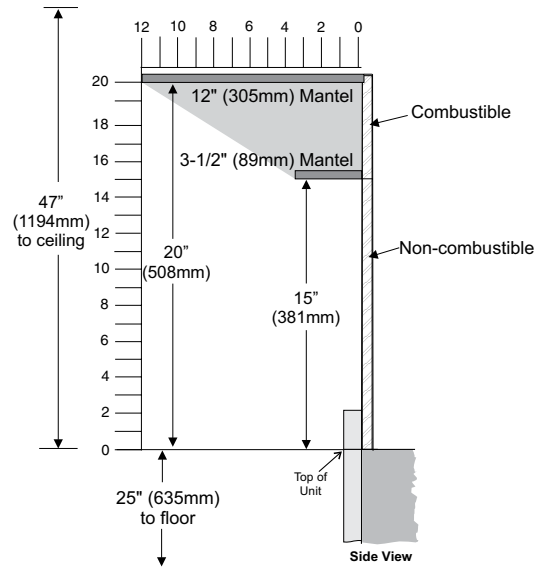

Because of the extreme heat this fireplace emits, the mantel clearances are critical.

Note: A non-combustible mantel may be installed at a lower height if the framing is made of metal studs covered with a non-combustible board.

Mantel can be installed anywhere in shaded area or higher using the above scale.

Note: Ensure the paint that is used on the mantel and the facing is "heat resistant" or the paint may discolour.

MINIMUM FIREPLACE OPENING

The minimum fireplace opening for the Regency gas fireplace insert is shown in the following diagram and the table:

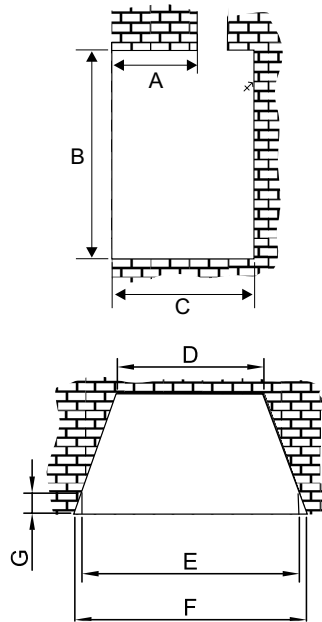

	Max Lintel Bar Depth A	Height B	Depth C	Width (Rear) D	Width (Front) E	Width F	Front Depth Prior to Taper G
Low Profile Faceplate with Spacer	8"	24 3/16"	16 3/4"	25"	N/A	32 1/4"	N/A
Low Profile Faceplate without Spacer	9 1/4"	25 1/2"	18"	25"	N/A	35 1/4"	N/A
Vignette faceplate with Spacer	9 1/2"	24"	16 3/4"	25"	N/A	32 1/2"	N/A
Vignette Faceplate without Spacer	12"	25 1/2"	19 1/8"	25"	34 5/8"	35 3/4"	2"

VENTING

This appliance is designed to be attached to two 3" (76mm) co-linear aluminium flex running the full length of the chimney. The flue length must be a minimum length of 8' (2.44m) and a maximum of 35' (10.7m). See chart above for minimum distances from roof. Periodically check that the vent is unrestricted.

Masonry chimneys may take various contours which the flexible liner will accommodate. However, **keep the flexible liner as straight as possible**, avoid unnecessary bending.

Part #	Description
948-305	3" Flex - 35 ft.
946-529	Regency Co-linear DV Vertical Termination Cap

Alternate Approved Caps

46DVA-VC	Vertical Termination Cap
46DVA-VCH	High Wind Cap
46DVA-GK	3" Co-linear Adaptor with flashing

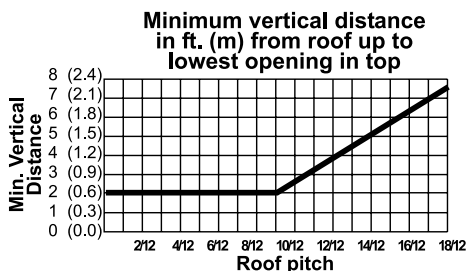
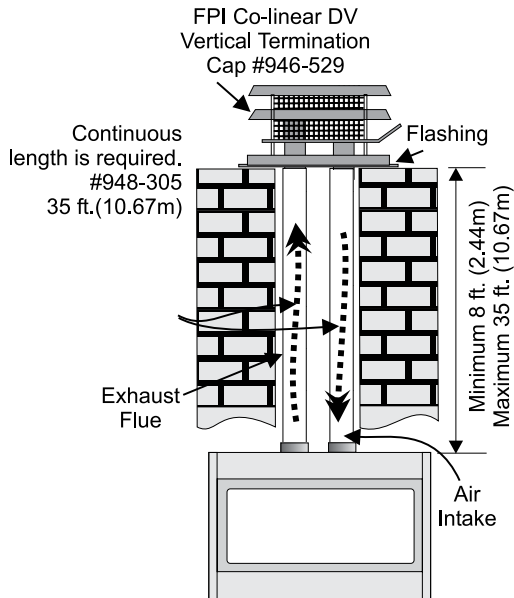

In areas of consistently high winds, we recommend using the Simpson Dura-Vent System (46DVA-GK adaptor and 46DVA-VCH high-wind cap).

The Air Intake pipe must be attached to the inlet air collar of the termination cap.

FLUE LINER INSTALLATION

1. Cut the flex liner as required.
2. Mark the end of one liner with an "E" to indicate Exhaust.
3. Connect the other end of the above liner to the exhaust side of the termination adaptor, seal connection with high temperature silicone. Secure with 3 screws.
4. Connect the 2nd liner to the inlet side of the adaptor, seal connection with high temperature silicone. Secure with 3 screws.
5. Install flashing.
6. Insert both liners into chimney, passing through the damper opening.
7. Install termination cap.
8. Remove vent connector plate by removing screws located on top/front of appliance.
9. Connect the marked end of the liner to the exhaust collar of the vent connector plate marked with an "E", seal connection with high temperature silicone. Secure with 3 screws.
10. Connect the 2nd liner to the intake collar, seal connection with high temperature silicone.
11. Align vent connector plate with guides on unit.
12. Slide unit into masonry opening, while ensuring that the slot at the rear of the connector plate mates up with the hold down plate on the unit.
13. Secure with screw—removed from Step 8. Secure with 3 screws.

NOTE:

1. Final gas connection should be made after unit is in place to avoid damage to line when pushing the unit into position.
2. Mill-pac may be used instead of high temperature silicone and screws may be used instead of gear clamps at connections of liner to inlet and vent collars.