

City Series CV72E Gas Fireplace

Model	CV72E-NG	CV72E-LP
Fuel Type	Natural Gas	Propane
Minimum Supply Pressure	5" W.C. (1.25 kPa)	11" W.C. (2.73 kPa)
Manifold Pressure - High	3.5" W.C. (0.87 kPa)	10" W.C. (2.49 kPa)
Manifold Pressure - Low	1.6" W.C. (0.40 kPa)	6.4" W.C. (1.59kPa)
Orifice Size -Altitude 0-4500 ft.	#30 DMS	#47 DMS
Minimum Input Altitude 0-4500 ft. (0-1372m)	32,000 BTU/h (9.37 kW)	36,000 BTU/h (10.55 kW)
Maximum Input Altitude 0-4500 ft. (0-1372m)	46,500 BTU/h (13.63 kW)	45,500 BTU/h (13.33 kW)
Vent Sizing	5" Inner / 8" Outer	5" Inner / 8" Outer

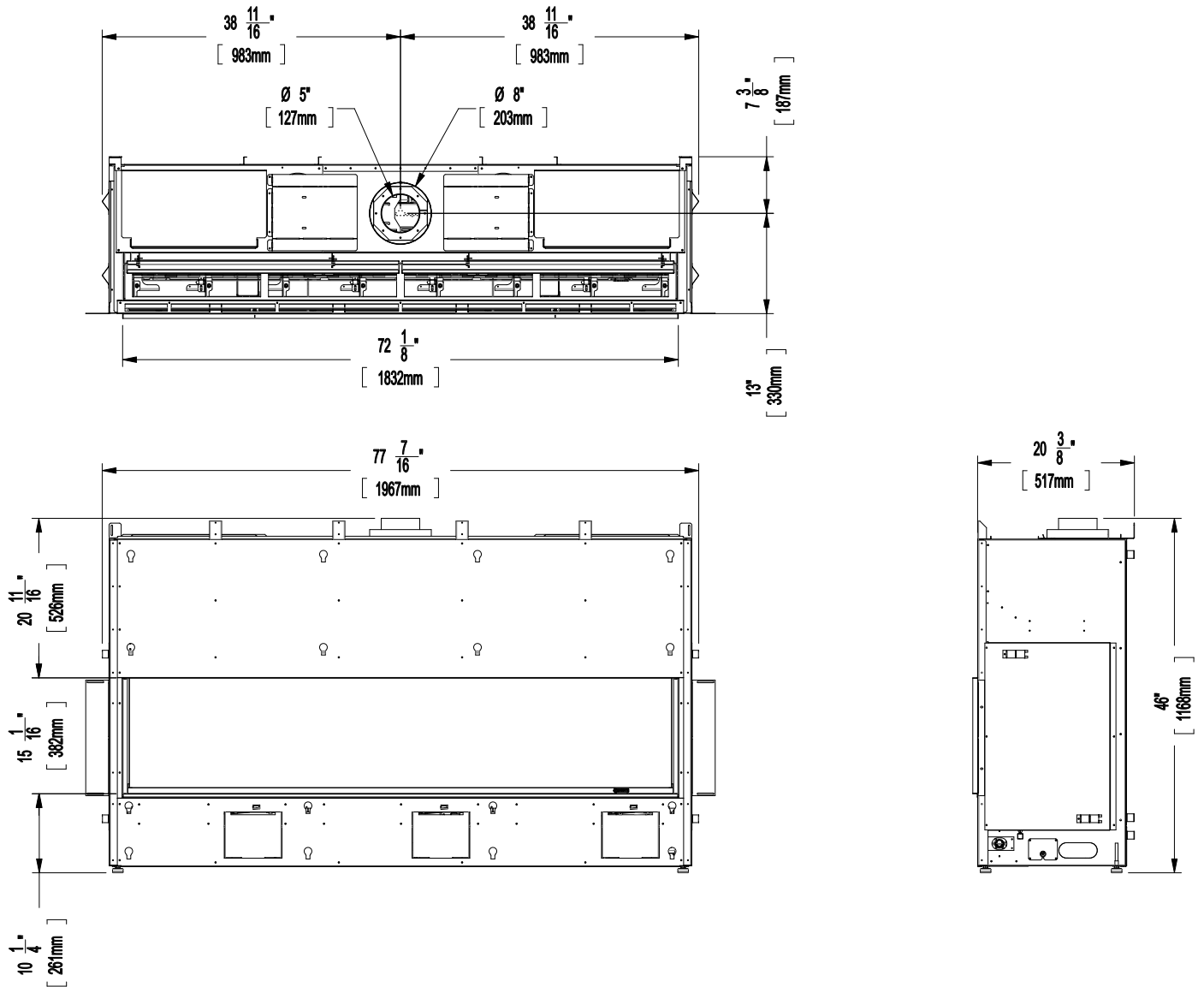

CLEARANCES CV72E

The clearances listed below are Minimum distances unless otherwise stated:

A major cause of chimney related fires is failure to maintain required clearances (air space) to combustible materials. It is of the greatest importance that this fireplace and vent system be installed only in accordance with these instructions.

Clearance: single sided	Dimension	Measured From:
A: Mantel Height (min.)	**	Top of Fireplace Opening
B1: From Floor	min. 0"	Bottom of Fireplace Opening
B2: Opening Height	15-1/16" (383mm)	Bottom/Top of Fireplace Opening
C: Sidewall (on one side)	8" (203mm)	Side of Fireplace Opening
D: Mantel Depth (max.)	**	
E: Alcove Width	88" (2135mm)	Sidewall to Sidewall (Minimum)
F: Alcove Depth	36" (914mm)	Front to Unit (Maximum)
G: Ceiling (in front of fireplace)	61-3/4" (1568mm)	Top of Fireplace Opening
H: Convection Air Outlet	*288 square inches	
J: Convection Air Outlet Opening Offset	*0-2" (0-51mm)	Max. offset from top of chase enclosure
K: Chase Enclosure (Min.)	87" (2210mm)	From base of unit/floor
Hearth	0"	No hearth required

** See mantel clearances chart - next page.

Flue Clearances to Combustibles	
Horizontal - Top	3"
Horizontal - Side	2"
Horizontal - Bottom	2"
Vertical	2"
Passing through wall/floor/ceiling - when firestop is used.	1-1/2"

Note: This appliance uses 5" x 8" venting

*A minimum of 288 square inches of open area, not lower than 0-2" from top of enclosure, required for all installations

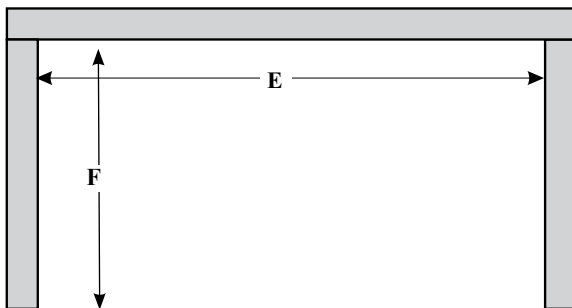
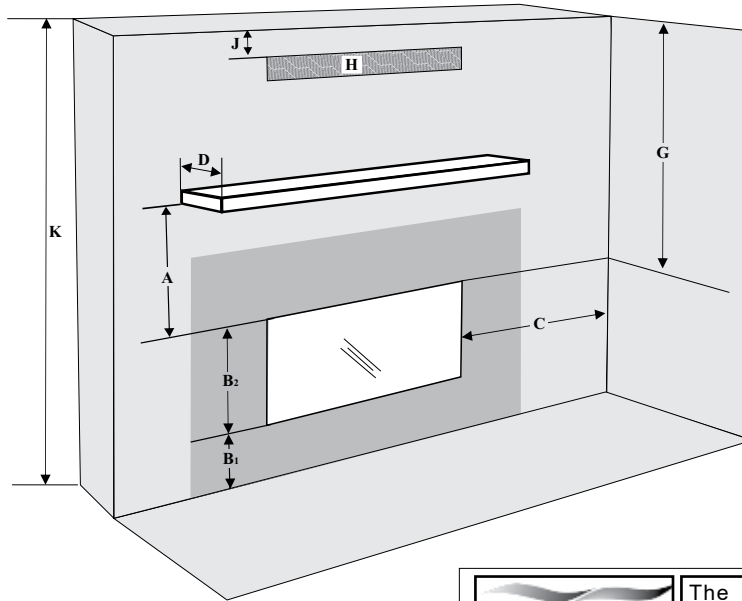

Alcove

Heat Wave The **HeatWave** Duct Kit has different clearance and framing requirements, check the **HeatWave** manual for details.

Caution Requirements
The top, back and sides of the fireplace are defined by standoffs. The metal ends of the standoff may **NOT** be recessed into combustible construction.

WARNING
Fire hazard is an extreme risk
if these clearances (air space) to combustible materials are not adhered to. It is of greatest importance that this fireplace and vent system be installed only in accordance with these instructions.

MANTEL CLEARANCES CV72E

Combustible mantel clearances from top of front facing are shown in the diagram on the right.

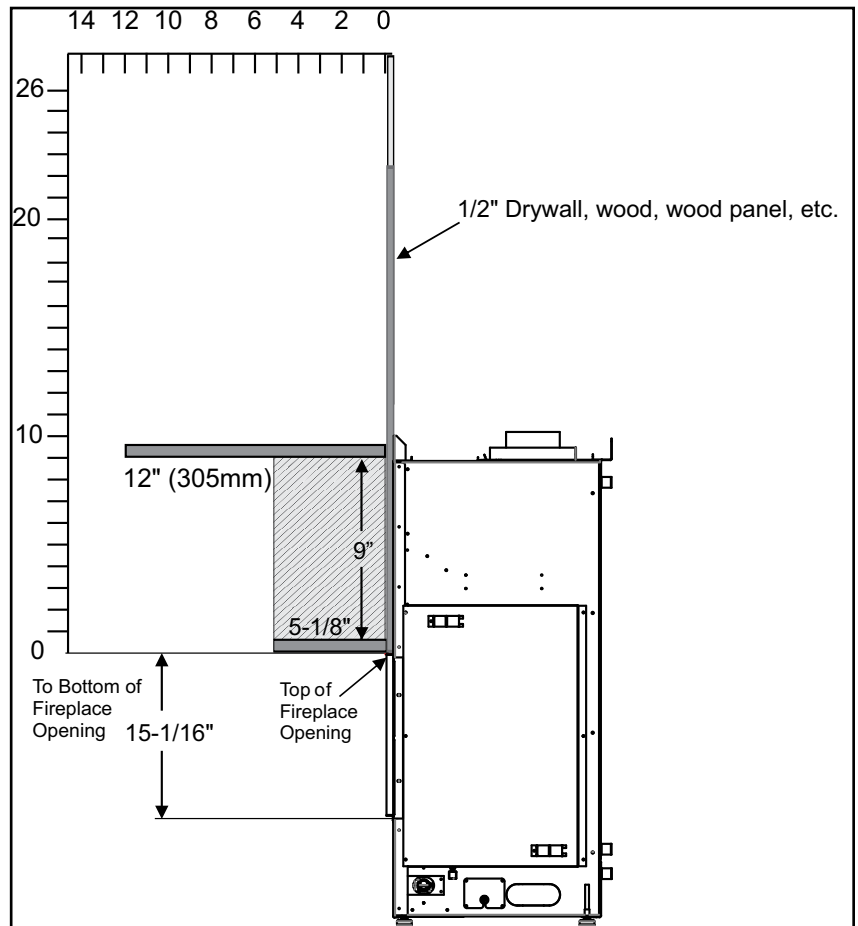

MANTEL LEG CLEARANCES

Combustible mantel leg clearances as per diagram:

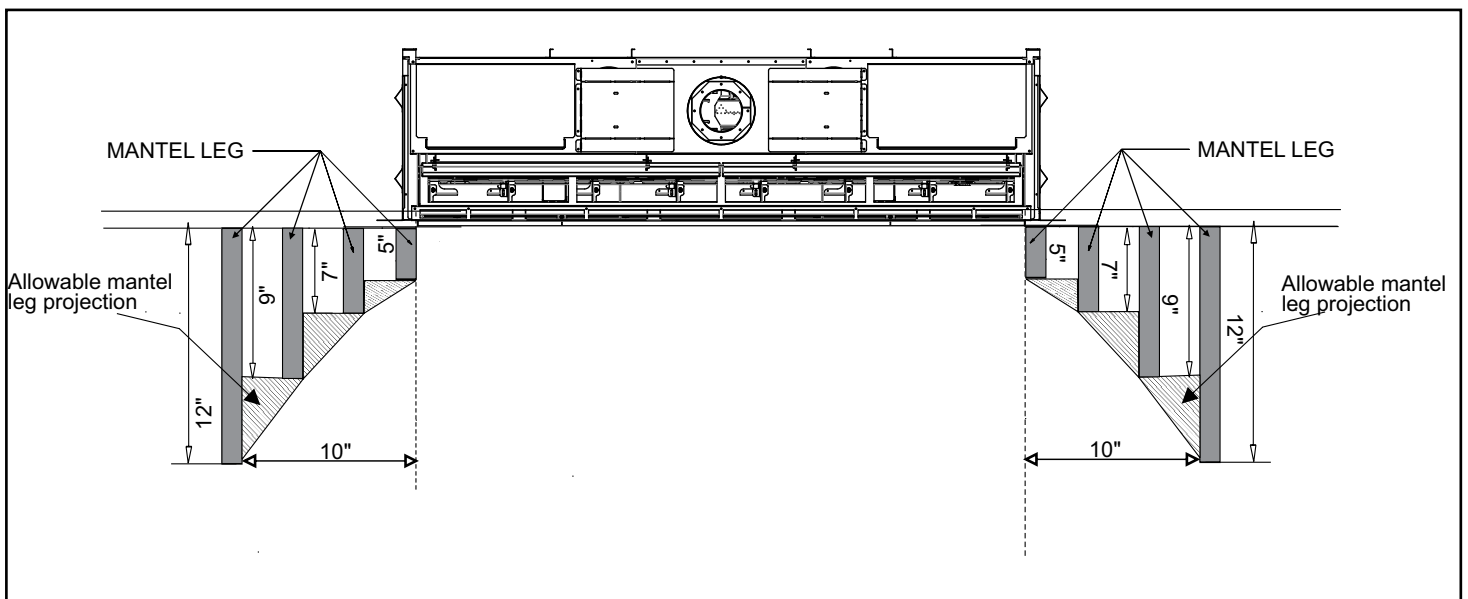

FRAMING DIMENSIONS CV72E

NOTE: Framing may be constructed of combustible material (ie. 2 x 4) and does not require steel studs.

Framing Dimensions	Description	CV72E
A	Framing Height	51" (1295mm)
B	Framing Width	78" (1981mm)
C	Framing Depth	20-5/8" (524mm)
D	Minimum Height to Combustibles	87"(2210mm)
E	Corner Wall Depth	82-1/8" (2086mm)
F	Corner Facing Wall Width	116-3/16" (2951mm)
G	Vent Centerline Height	55-1/4" (1403mm)
I	Gas Connection Opening Height	2" (51mm)
J	Gas Connection Height	3-7/8" (98mm)
K*	Gas Connection Inset-Centre Opening	36-1/4" (921mm)
L	Gas Connection Opening Width	5" (127mm)

* See manual for alternate Gas/ Electrical connection options

With the lift handles adding approximately 4 inches to the overall width of the appliance, In cases where the appliance would need to be raised off the ground in order to slide it into the framed opening, it is suggested that either the framing width change from 78" to 82" so that the appliance could be easily slid into position with the handles remaining on the appliance, or alternatively create a platform in front of the framed opening where the lift handles could be removed prior to sliding the appliance into its final position. Alternatively, If raised off he ground, the framing could be installed afterwards once appliance has been put into place and lift handles removed in order to keep the framing width at 78". Ensure that the wood base that the appliance will sit on is strong enough to support the full weight of this appliance. The overall weight of this appliance is 529 pounds (shipping weight).

Note: A combined minimum of 288 square inches of open area is required for the convection air outlet to cool the enclosure. Ensure clearances for Convection Air Outlets are met. See clearances CV72E in the manual as there are different methods as to how this can be achieved.

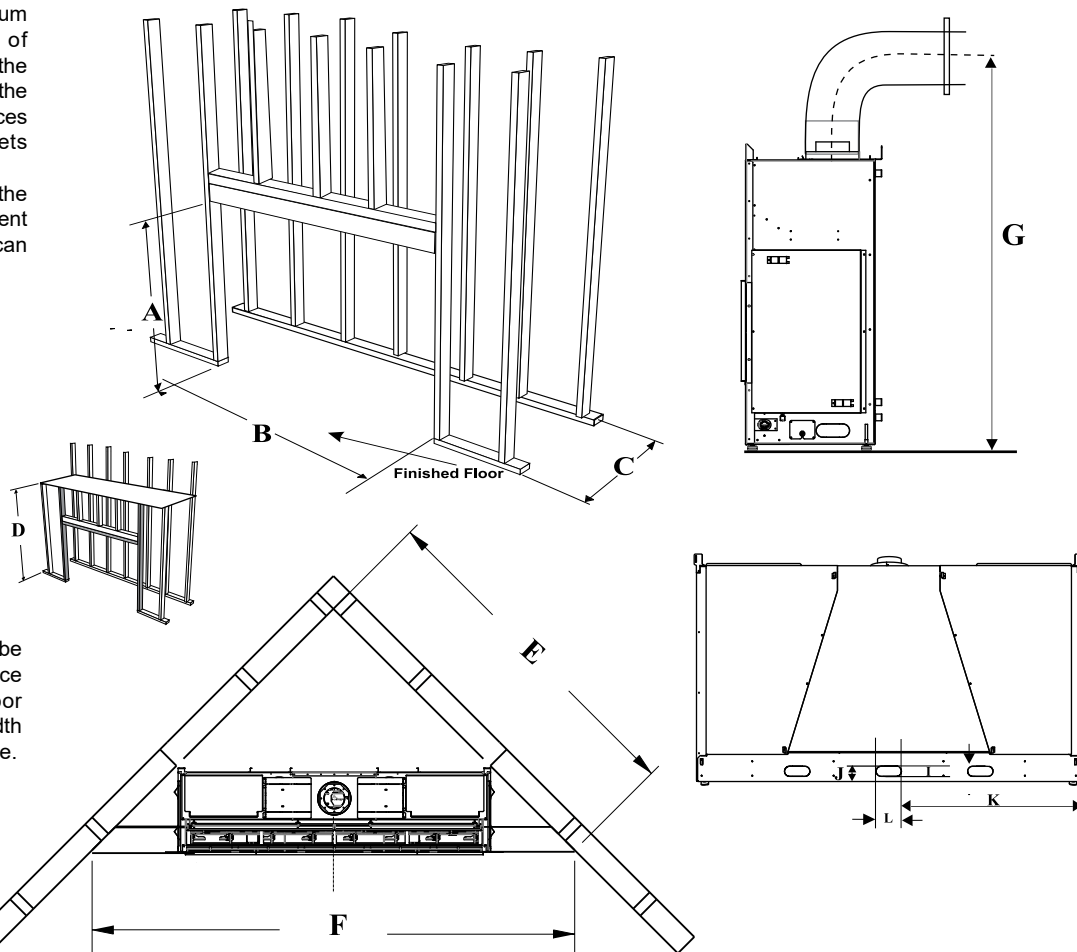

Note: This appliance must be installed on a solid surface such as a plywood floor which must be the full width and depth of the appliance.

VENTING INTRODUCTION

The CV72E uses the "balanced flue" technology Co-Axial system. The inner liner vents products of combustion to the outside while the outer liner draws outside combustion air into the combustion chamber thereby eliminating the need to use heated room air for combustion and losing warm room air up the chimney.

Note: These flue pipes must not be connected to any other appliance.

The gas appliance and vent system must be vented directly to the outside of the building, and never be attached to a chimney serving a separate solid fuel or gas burning appliance. Each direct vent gas appliance must use it's own separate vent system. Common vent systems are prohibited.

VENTING ARRANGEMENT FOR HORIZONTAL TERMINATIONS

The diagram shows all allowable combinations of vertical runs with horizontal terminations, using one 90° (two 45° elbows equal one 90° elbow).

Note: Must use optional rigid pipe adapter (Part# 770-994) when using Rigid Pipe Venting Systems)

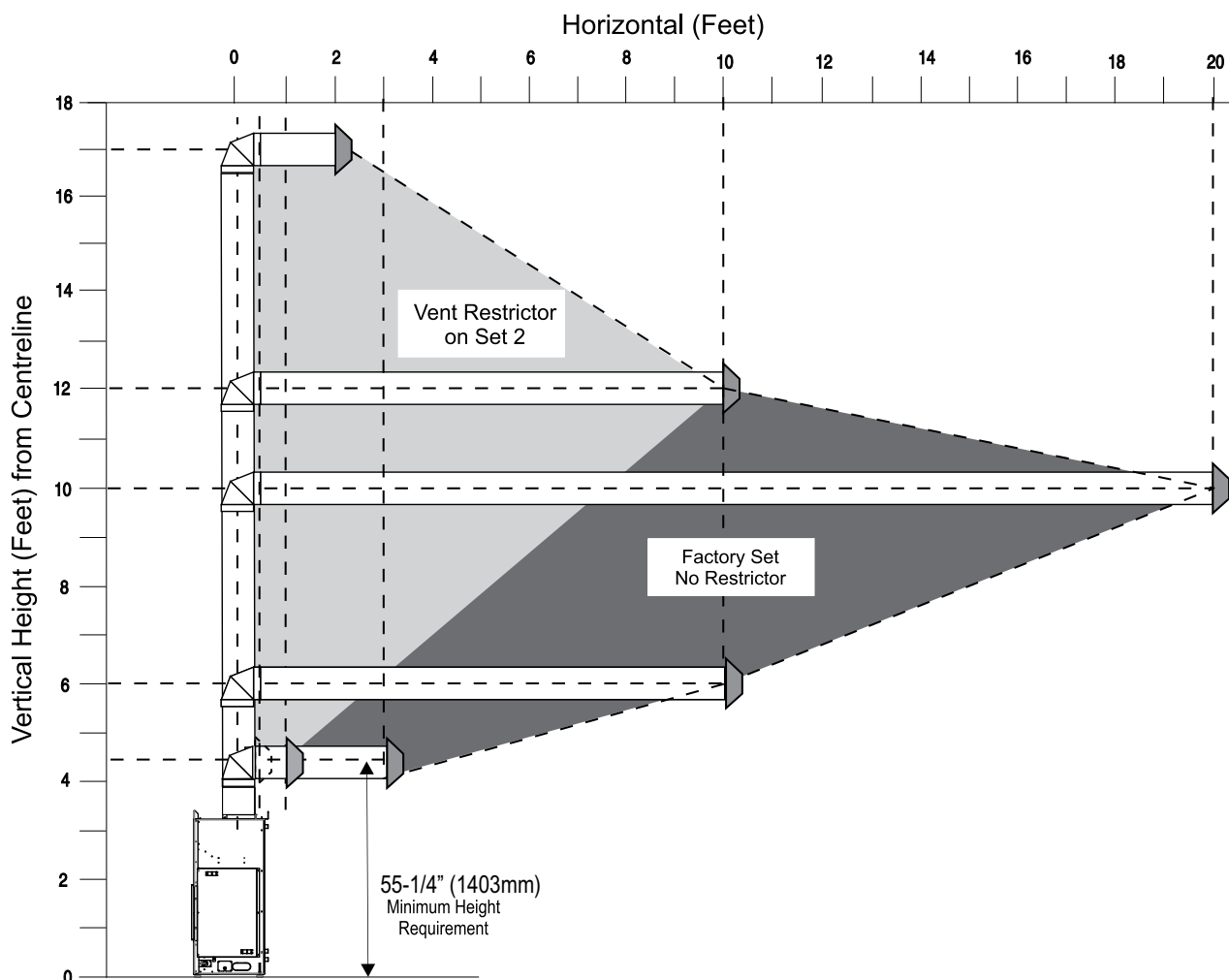

VENT RESTRICTOR SETTING:

Vent restrictor factory set at Set 0.

Refer to the "Vent Restrictor Position" section for details on how to change the vent restrictor from the factory setting of Set 0 to Set 2 if required.

Note: For horizontal terminations the Regency Direct Vent Flex System may be used for installations with a maximum continuous vent length of up to 10 feet. If longer runs are required, rigid pipe must be used.

- Maintain clearances to combustibles as listed in "Clearances" section
- Horizontal vent must be supported every 3 feet.
- Firestops are required at each floor level and whenever passing through a wall.
- A vent guard should be used whenever the termination is lower than the specified minimum or as per local codes.

HORIZONTAL TERMINATIONS RIGID PIPE 5" X 8"

The diagrams below shows examples of horizontal termination arrangements using one, two, or three 90° elbows (two 45° elbows equal one 90° elbow)

1. A maximum of three 90° elbows are permitted.

2. Minimum distance between elbows is 1 ft. (305mm).

- Maintain clearances to combustibles as listed in the "Clearances" section.
- Horizontal vent must be supported every 3 feet.
- Firestops are required at each floor level and whenever passing through a wall.
- Must use optional rigid pipe adaptor (Part# 770-994) when using rigid pipe vent systems.
- A vent guard should be used whenever the termination is lower than the specified minimum or as per local codes.
- Flex system can only be used up to 10 feet - otherwise rigid venting must be used.

HORIZONTAL VENTING WITH TWO (2) 90° EL-BOWS

One 90° elbow = Two 45° elbows.

Option	V	H + H1	With these options, maximum total pipe length is 30 feet with minimum of 6 feet total vertical and maximum 8 feet total horizontal. Please note minimum 1 foot between 90° elbows is required.
A)	1' Min.	2' Max.	
B)	2' Min.	4' Max.	
C)	3' Min.	5' Max.	
D)	4' Min.	6' Max.	
E)	5' Min.	7' Max.	
F)	6' Min.	8' Max.	
Restrictor Set 0 - Factory Setting			

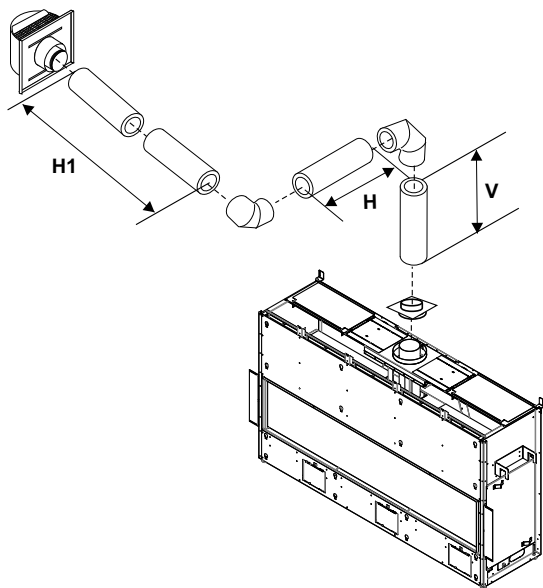

HORIZONTAL VENTING WITH THREE (3) 90° EL-BOWS

One 90° elbow = Two 45° elbows.

Option	V	H	V + V1	H + H1	With these options, max. total pipe length is 30 feet with min. of 12 feet total vertical and max. 9 feet total horizontal. Please note min. 1 foot between 90° elbows is required.
A)	1' Min.	1' Max.	2' Min.	2' Max.	
B)	1' Min.	2' Max.	3' Min.	3' Max.	
C)	2' Min.	2' Max.	5' Min.	4' Max.	
D)	3' Min.	2' Max.	7' Min.	5' Max.	
E)	4' Min.	3' Max.	9' Min.	6' Max.	
F)	5' Min.	4' Max.	10' Min.	7' Max.	
G)	6' Min.	5' Max.	11' Min.	8' Max.	
H)	7' Min.	6' Max.	12' Min.	9' Max.	
Restrictor Set 0 - Factory Setting					

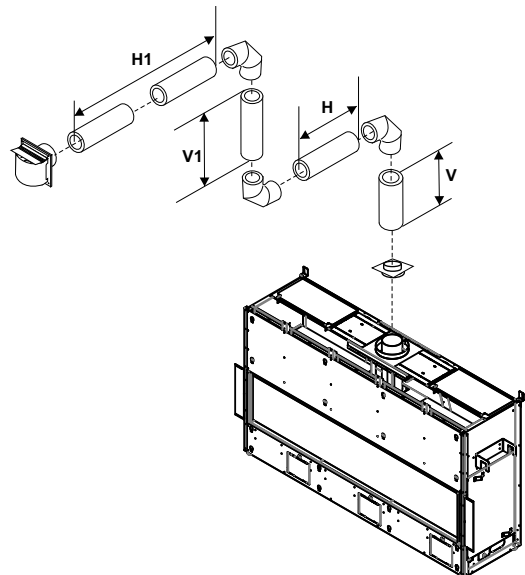

VENTING ARRANGEMENT FOR VERTICAL TERMINATIONS

Vertical Venting with straight Vertical venting and or with a max. of two (2) 90° Elbows (1 - 90° = 2 - 45°)

The shaded area in the diagram shows all allowable combinations of straight vertical and offset to vertical terminations, using two 90° elbows, with **Rigid Pipe Venting Systems**.

Two 45° elbows equal to one 90° elbow.

- Vent must be supported at offsets.
- Minimum distance between elbows is 1 ft. (305mm).
- Maintain clearances to combustibles as listed in the "Clearances" section.
- Horizontal vent must be supported every 3 feet.
- Firestops are required at each floor level and whenever passing through a wall.
- Must use optional rigid pipe adaptor (Part# 770-994) when using rigid pipe vent systems.
- Refer to the "Vent Restrictor Position" section for details on how to change the vent restrictor from the factory setting of Set 0 through to Set 3 if required.

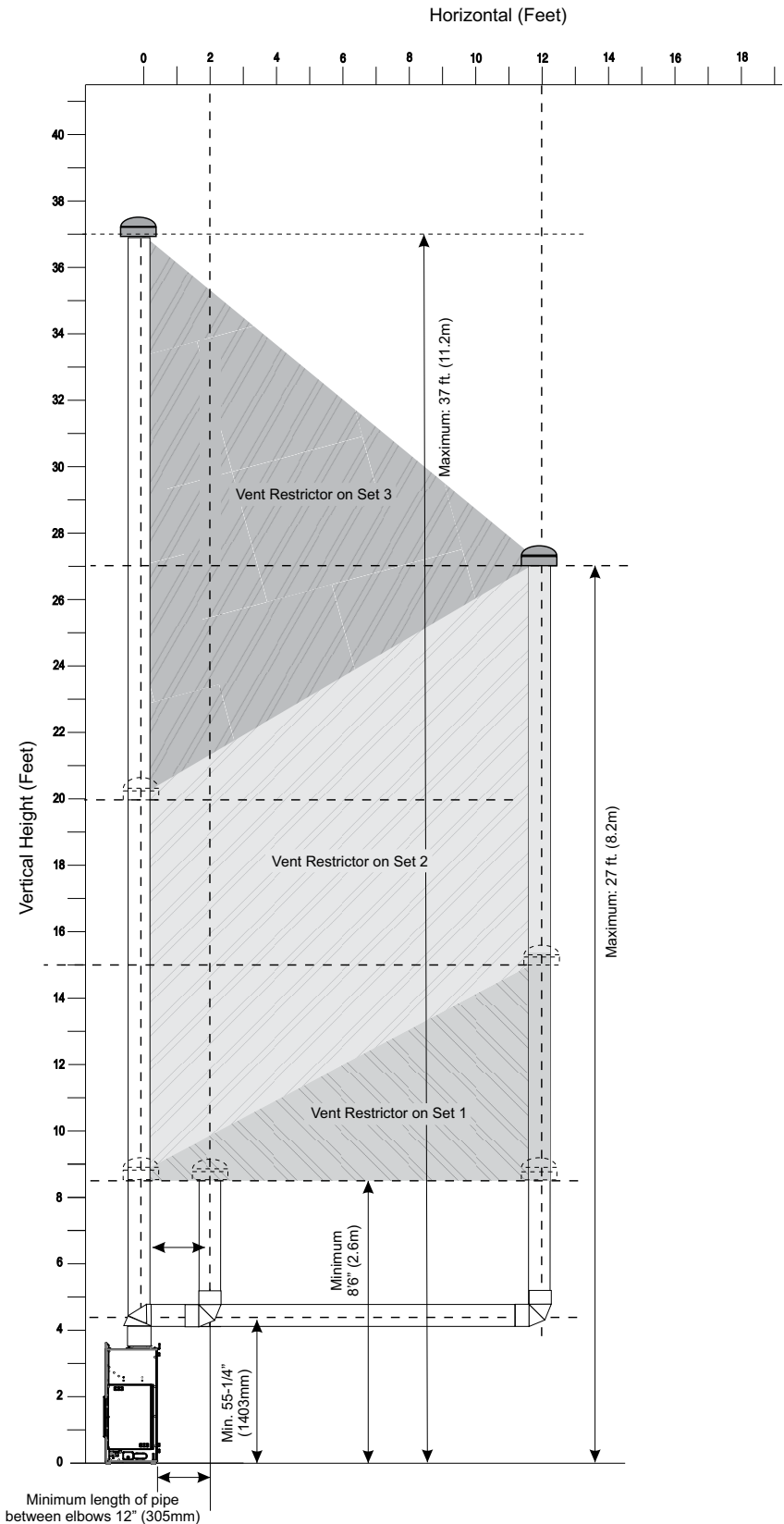

VERTICAL TERMINATIONS RIGID PIPE 5" X 8"

- Two 45° elbows equal to one 90° elbow. Maximum of six 45° elbows allowed.
- Vent must be supported at offsets.
- Minimum distance between elbows is 1 ft. (305mm).
- Maintain clearances to combustibles as listed in the "Clearances" section.
- Horizontal vent must be supported every 3 feet.
- Firestops are required at each floor level and whenever passing through a wall.
- Must use optional rigid pipe adaptor (Part# 770-994 when using rigid pipe vent systems)

Vertical Venting with Three (3) 90° Elbows

One 90° elbow = Two 45° elbows.

Option	V	H + H1	V + V1	
A)	1' Min.	2' Max	3' Min.	With these options, max. total pipe length is 30 feet with min. of 10 feet total vertical and max. 8 feet total horizontal. Please note min. 1 foot between 90° elbows is required.
B)	2' Min.	3' Max	4' Min.	
C)	3' Min.	4' Max	6' Min.	
D)	4' Min.	5' Max	7' Min.	
E)	5' Min.	6' Max	8' Min.	
F)	6' Min.	7' Max	9' Min.	
G)	7' Min.	8' Max	10' Min.	
Lengths do not include elbow indicated Restrictor Set 0 - Factory Setting				

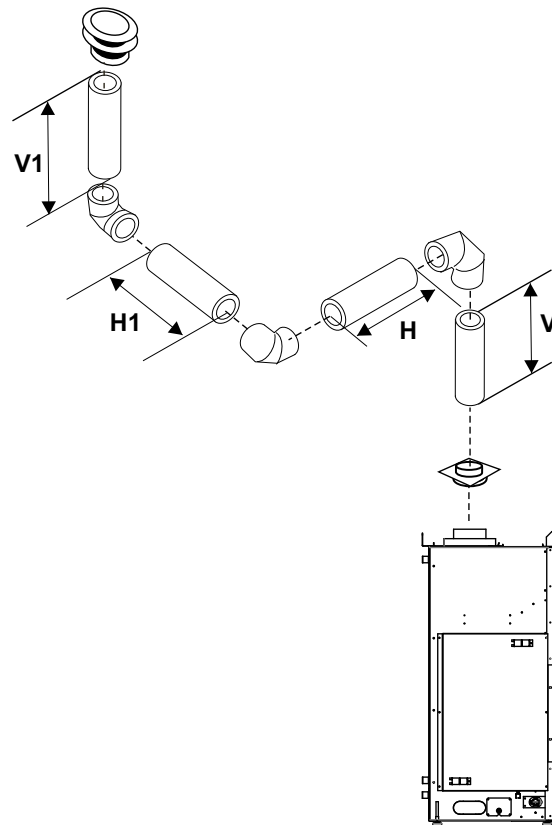

GUIDELINES FOR INSTALLING A TV / ARTWORK ABOVE THE UNIT

Note: All wiring should stay free and clear of the vent system to avoid damage due to heat. We recommend using a metal receptacle box and BX cable (120 volt wire protected by metal sheathing) if located directly in front of the vent system. Ensure wiring is secured without any sag.

ZERO CLEARANCE TO TV: While most consumers prefer to centrally locate a wall mounted TV, the "Cool-Touch Wall Technology" means that the bottom edge of the TV can be installed flush with the bottom edge of the ventilated fireplace chase opening.

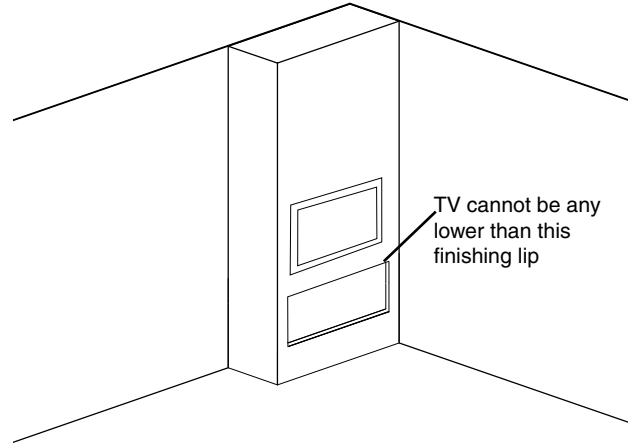

MAXIMUM TV RECESS

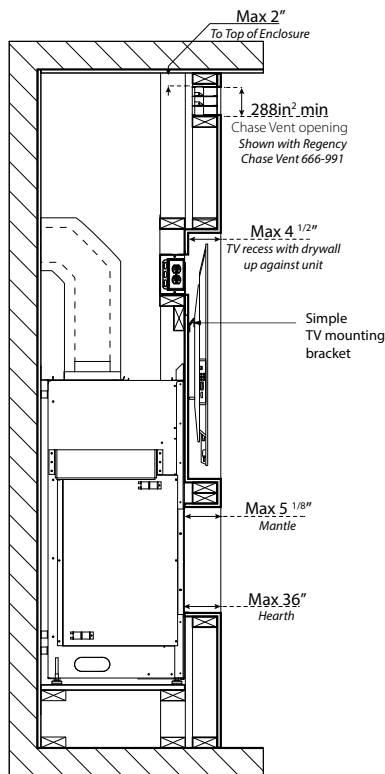

4 5/8" maximum TV recess

FLUSH TV WITH HEARTH

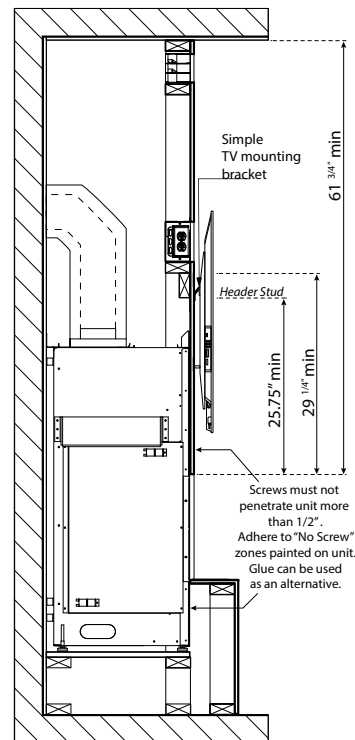

Note: The TV mounting bracket can not be secured directly to the appliance. It must be secured to framing. The TV depicted in the picture may need to be higher depending on the style of TV mounting bracket used. The mounting bracket shown is a simple single strip TV secured to framing.