



OUTDOOR GAS FIREPLACES



regency-fire.com

WHY CHOOSE REGENCY?

At Regency, our past 40 years have been focused on providing a high-level of service while building high-quality and reliable products that our customers can enjoy for years to come.

HIGH-QUALITY

Producing a high-quality product has been at the very heart of what we do from when that very first stove rolled off the production line over 40 years ago to today. We are ever-focused on producing quality products for our customers that will last for years to come.

BEST WARRANTY

A fireplace should be reliable and should work right the first time it is used, and the 1,000th. A core part of our business is making sure that we are building long-lasting, durable, high-quality products; we back-up that commitment with the industry's best warranty on all our products.

COST-EFFICIENT

Enjoy the outdoors for longer. Controllable zone heating allows you to extend your patio season earlier in the spring and later into the fall. Enjoy your patio all night long with Regency's outdoor gas fireplaces.

Why Regency? Because it's **more** than a fireplace!



TABLE OF CONTENTS

Regency Grandview Outdoor Fireplaces

G1200P 04

G800EC 06

G600EC 08

Regency Plateau® Firetable

PTO30CFT 12

Regency Horizon™ Outdoor Gas Fireplaces

HZ042 14

HZ060 16

Regency Plateau® Gas Burners

PTO30, PTO50 18

Design Choices & Options 22



REGENCY GRANDVIEW™ - G1200P

Large Gas Fireplace



PREMIUM TRADITIONAL FIREPLACE

Experience the stunning flame picture of the G1200 traditional gas fireplace. Featuring our latest burner technology, this split flow infusion burner provides unmatched realism and flame control. Customize with mix-and-match accessories and 3 log set options.

The Grandview G1200 is a beautiful and powerful fireplace that will make any home feel warm and stylish. It's designed to fit perfectly in any room and offers great flexibility with many options to customize its look

STANDARD FEATURES

- NEW innovative split flow infusion burner that creates the most realistic flame package
- Largest viewing area in its class
- Standard top down and ember-bed lighting
- Integrated Invisimesh safety screen
- Cool Wall system to allow for flexible finishing options
- Flame height adjustment control
- Electronic ignition with Proflame II GTMF remote control
- Natural gas
- Limited lifetime warranty

OPTIONS

- Multiple log set choices: oak, birch or driftwood
- Interior panels in Rustic Brown, Volcanic Black, and Herringbone
- Finishing trims for easy finishing around the fireplace
- Variable speed blower (Non-combustible finishing install only) (Outdoor conversion kit required)
- Chase vent (cool wall installations)
- Propane conversion kit
- Outdoor conversion kit



G1200P - Oak log set with herringbone brick panels



G1200P - Birch logs with volcanic black brick panels



G1200P - Driftwood logs, volcanic stones and reflective black glass panels

SPECIFICATIONS	NATURAL GAS	PROPANE
Max. Input (BTU)	53,000	53,000
Turn down to (BTU)	13,500	13,500
Efficiency (steady state)	72.58%	74.08%
EnerGuide Rating (Canada only)	66.58%	67.96%

DIMENSIONS	
Width	55"
Height	42-3/4"
Depth	28-7/8"
Glass Viewing Area	1200 sq. in.

REGENCY GRANDVIEW™ - G800EC • G800C • G800EH

Medium Gas Fireplaces



YOUR FIREPLACE, YOUR WAY

Select your breathtaking flame picture and accessories to craft a truly unique fireplace. With our patented Cool Wall technology, the Regency Grandview™ G800 is the first of our Grandview™ series of gas fireplaces designed to maximize choice and customization.

STANDARD FEATURES

- Clean front design
- Largest viewing area in its class
- Top down and ember-bed lighting (G800EC/G800EH)
- Integrated safety screen
- Ceramic glass
- Standing Pilot (Direct Spark Ignition - G800C) (US Only)
- Flame height adjustment control
- Proflame II GTMF remote control (G800EC, G800EH only)
- Electronic ignition (G800EC, G800EH only)
- Rear or top vent for versatile installations (G800EC, G800C only)
- Natural gas
- Limited lifetime warranty

OPTIONS

- Choose from a log grate and traditional style log package or contemporary crystal tray
- Cool Wall system
- Brick panels in a variety of colors and designs
- Inner reflective panels in black enamel
- Inner painted black steel panels
- Surrounds in various colors
- Finishing trims for easy finishing around the fireplace
- Variable speed blower (Outdoor conversion kit required)
- Chase vent (cool wall installations)
- Propane conversion kit
- ON/OFF remote control (G800C) (US Only)
- AstroCap® venting system
- Outdoor conversion kit



G800EH - Birch log set and castlestone brick panels



G800EC/G800C - Iceberg crushed glass, volcanic stones and black steel panels



G800EC/G800C - Oak log set and herringbone brick panels



G800EC/G800C - Iceberg crushed glass, black steel panels and black faceplate



G800EC/G800C - Birch log set with brown brick panels and antique copper faceplate



G800EH - Driftwood log set and volcanic black brick panels and brushed nickel faceplate

SPECIFICATIONS	G800EC		G800C		G800EH		DIMENSIONS
	NATURAL GAS	PROPANE	NATURAL GAS	PROPANE	NATURAL GAS	PROPANE	
Input (BTU)	27,000	25,500	27,000	26,500	36,000	34,000	Width 35-7/8"
Turn down to (BTU)	15,000	21,000	15,000	14,500	19,500	27,000	Height 33-7/8"
Efficiency (steady state)	65.20%	68.16%	61.12%	63.62%	65.20%	68.16%	Depth 16-7/8"
EnerGuide Rating (Canada only)	55.96%	57.74%	55.96%	55.03%	58.73%	57.94%	Viewing Area 800 sq. in.

REGENCY GRANDVIEW™ - G600EC • G600C

Small Gas Fireplaces



SMALL FIREPLACE, BIG FLAME

This Regency Grandview™ G600 encapsulates the entire series' customization and flexibility in a more compact size. Ideal for smaller spaces or zone heating, this unit makes a bold impact.

STANDARD FEATURES

- Clean front design
- Top down and ember-bed lighting (G600EC)
- Integrated safety screen
- Ceramic glass
- Flame height adjustment control
- Standing Pilot (Direct Spark Ignition - G600C) (US Only)
- Proflame II GTMF remote control (G600EC)
- Electronic ignition (G600EC)
- Rear or top vent for versatile installations
- Natural gas
- Limited lifetime warranty

OPTIONS

- Choose from a log grate and traditional style log package or contemporary crystal tray
- Cool Wall system to allow for any finishing material right to the edge of the fireplace
- Brick panels in a variety of colors and designs
- Inner reflective panels in black enamel
- Inner painted black steel panels
- Surrounds in various colors
- Finishing trims for easy finishing around the fireplace
- Variable speed blower (Outdoor conversion kit required)
- Chase vent (cool wall installations)
- Propane conversion kit
- ON/OFF remote control (G600C) (US Only)
- AstroCap® venting system
- Outdoor conversion kit



G600EC/G600C - Oak log set and rustic brown brick panels



G600EC/G600C - Oak log set and castlestone brick panels



G600EC/G600C - Birch log set, herringbone brick panels and black faceplate



G600EC/G600C - Ginger crushed glass and antique copper faceplate



G600EC/G600C - Iceberg crushed glass, volcanic stones and brushed nickel faceplate



G600EC/G600C - Driftwood log set and black steel panels

SPECIFICATIONS	G600EC		G600C	
	NATURAL GAS	PROPANE	NATURAL GAS	PROPANE
Input (BTU)	21,000	20,500	21,000	20,500
Turn down to (BTU)	11,500	16,500	11,500	11,000
Efficiency (steady state)	71.17%	72.80%	71.18%	72.71%
EnerGuide Rating (Canada only)	64.80%	67.22%	64.79%	66.76%

DIMENSIONS	
Width	31-7/8"
Height	29-7/8"
Depth	14-5/8"
Viewing Area	600 sq. in.

OPTIONS & ACCESSORIES FOR GRANDVIEW

CHOOSE YOUR LOOK



- INTERIOR PANEL
- INTERIOR OPTION
- FRONT OPTION (G600 AND G800)

MULTIPLE INTERIOR PANELS



Rustic Brown Brick Panels



Herringbone - Rustic Brown Brick Panels



Volcanic Black Brick Panels



Castlestone Grey (available for G600 & G800 series only)



Painted Black Steel Panels



Black Enamel Reflective Panels

MULTIPLE INTERIOR OPTIONS



Birch Log Set



Oak Log Set



Driftwood Log Set

G800 / G600

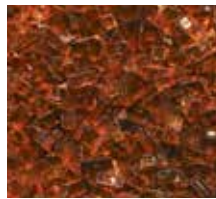

Crushed Glass - Ginger



Crushed Glass - Coal Black

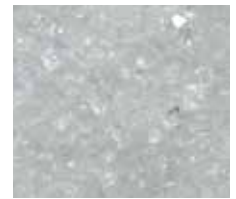

Crushed Glass - Iceberg



Volcanic Stones

MULTIPLE FRONT OPTIONS G800 / G600



Clean Front Finishing Trim



Outside Finishing Trim



Faceplate

FACEPLATE AVAILABLE IN THREE COLORS:



Black



Brushed Nickel



Antique Copper

GRANDVIEW SERIES INSTALLATION

Location

For the purposes of this installation manual the term "outdoor" means installed outside of the insulated building envelope within a weatherproof enclosure or existing solid-fuel burning fireplace having a minimum required overhang. The outdoor space may be attached or free standing to the main/primary structure and may or may not include walls.

Note

The fireplace will not perform as an exterior wall. If installed against an exterior wall we recommend the appliance enclosure or chase be constructed completely outside of the insulated building envelope and weather membrane. The fireplace must be permanently situated and connected to a fixed piping system, it is not portable.

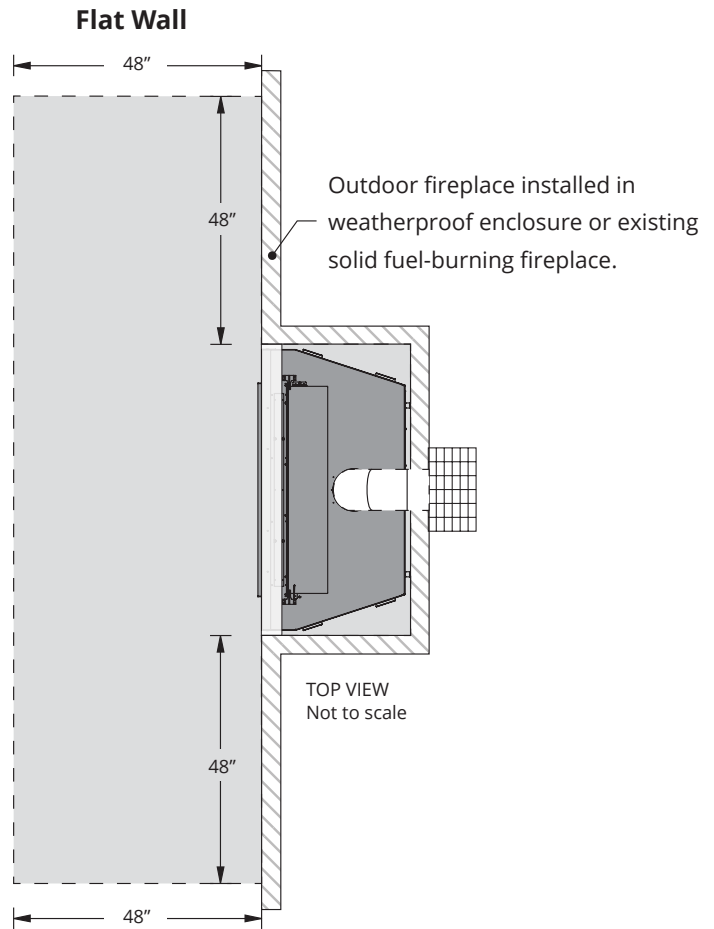

The minimum weatherproof overhang in front and at sides of the fireplace is 1/2 of the height of the overhang (as shown with 96" framing height) measured from the base of the unit.

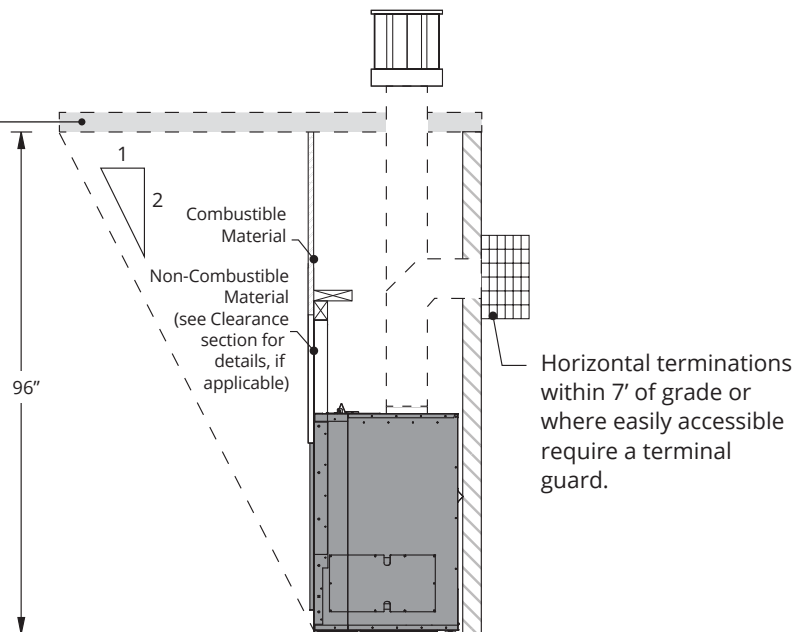

REGENCY PLATEAU® PTO30CFT

Freestanding Firetable



PTO30CFT shown with stainless steel top, crystals and glass wind shield.

LINGER OUTDOORS LONGER...IN STYLE

Regency's versatile firetable is perfect for outdoor entertaining. At 20" tall, the sleek linear style of the Regency Plateau Coffee Table creates the perfect gathering space. Included is a dining leaf that adds functionality as an outdoor table when the fireplace is not in use. The Plateau Firetable collection is crafted from the highest quality materials and durable construction, built to withstand the outdoor elements.

SPECIFICATIONS	NATURAL GAS	PROPANE
Input (BTU)*	49,000	48,000
Turn down to (BTU) *	18,000	15,000

* Figure will vary with individual conditions and fuel quality.

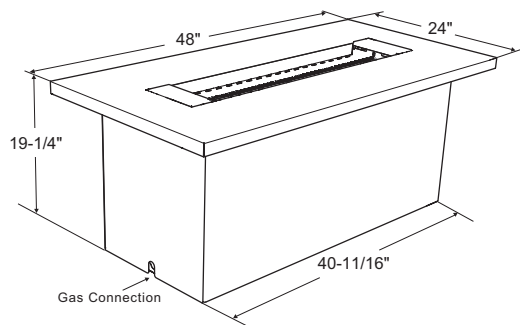



PTO30CFT shown with sunset bronze top, crystals and glass wind shield.

STANDARD FEATURES

- Propane
- Stainless steel linear burner
- Easy access on/off switch
- Match light ignition system
- Safety valve (turns gas off if flame goes out)
- Manual flame height adjustment
- Dining leaf adds functionality as an outdoor table when fireplace not in use
- Propane tank access & storage (11 lb tank)
- Approved for outdoor installation only
- No venting required

OPTIONS

- Stainless steel or sunset bronze powder coated top (must choose one)
- Crystals or firebeads in various colors (must choose one)
- Volcanic stones in various colors
- Ceramic driftwood log set
- Seasonal weather cover
- Tempered glass wind shield (4-pc) with seasonal weather cover - recommended
- 4 casters (wheels to replace leveling legs)
- Natural gas conversion kit

REGENCY HORIZON™ HZO42

Outdoor Gas Fireplace



HZO42 shown with crystals.

DESIGN YOUR OWN OUTDOOR FIREPLACE

Enjoy the drama of beautiful wide-angle flames amplified by a reflective stainless steel body. A tempered glass wind shield maintains the strong flame picture, while the seasonal weather cover (included) protects the fireplace when it's not in use. Choose from a host of fine fire bed selections to create a flame experience as unique as you.

SPECIFICATIONS	NATURAL GAS	PROPANE
Input (BTU)*	44,500	43,500

* Figure will vary with individual conditions and fuel quality.

DIMENSIONS	
Faceplate width	39-1/2"
Faceplate height	17"
Viewing area	449 sq. in.



HZO42 shown with driftwood ceramic log set & optional framing kit.

STANDARD FEATURES

- Natural gas or propane
- Stainless steel linear burner covered with copper crystals
- Stainless steel faceplate with seasonal weather cover
- Stainless steel heat deflector & inner panels
- Tempered glass wind shield
- Easy access on/off switch
- Electronic ignition system
- Safety valve (turns gas off if flame goes out)
- Runs on a battery pack
- Approved for outdoor installation only
- No venting required

OPTIONS

- Crystals or firebeads in various colors
- Volcanic stones in various colors
- Ceramic driftwood log set
- River pebbles
- Framing kit
- Hardwire kit (hardwire directly into household wiring)

REGENCY HORIZON™ HZO60

Outdoor Gas Fireplace



HZO60 shown in see-through application.

REGENCY'S LARGEST OUTDOOR GAS FIREPLACE EVER!

HZO60 is the perfect combination of style and comfort. This impressive 60" outdoor fire feature converts from single-sided to see-through design perspective. Harness the power of 64,000 BTU's to remove the chill from night air so you can enjoy your patio for longer!

SPECIFICATIONS	NATURAL GAS	PROPANE
Input (BTU)*	64,000	62,000

* Figure will vary with individual conditions and fuel quality.

DIMENSIONS	
Width	60"
Height	17"
Depth	18"
Viewing area	up to 1,020 sq. in.



HZO60 shown in single-sided application.

STANDARD FEATURES

- Natural gas
- Stainless steel linear burner
- Single-sided or see-through design
- Stainless steel inner panels
- Tempered glass wind shield
- Easy access on/off switch
- Electronic ignition system
- Safety valve (turns gas off if flame goes out)
- Runs on a battery pack
- Approved for outdoor installation only
- No venting required

OPTIONS

- Stainless steel faceplate
- Stainless steel burner perimeter finishing trim
- Stainless steel burner cover
- Crystals or firebeads in various colors (must choose one)
- Volcanic stones in various colors
- Ceramic driftwood log set
- Hardwire kit (hardwire directly into household wiring)
- Propane conversion kit

REGENCY PLATEAU® BURNER PTO30 & PTO50

Outdoor Gas Burner



Two PTO50's (100") connected end to end, shown in custom application.

CREATE THE BACK YARD OF YOUR DREAMS

These sleek linear stainless-steel burners add warmth and ambiance to any outdoor space. Customize your design by connecting two 50" burners for a 100" feature or pairing with a 30" burner for an 80" setup. The 30" (PTO30) unit can also be doubled to 60". Perfect for homeowners and designers, this versatile burner transforms your outdoor sanctuary into a stunning retreat

SPECIFICATIONS	30"		60"	
	NATURAL GAS	PROPANE	NATURAL GAS	PROPANE
Input (BTU)*	50,000	49,000	100,000	98,000

SPECIFICATIONS	50"		100"	
	NATURAL GAS	PROPANE	NATURAL GAS	PROPANE
Input (BTU)*	64,000	62,000	128,000	196,000

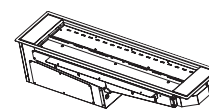

30"
PTO30 burner

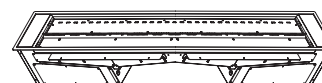

60"
Two PTO30 burners
connected end to end

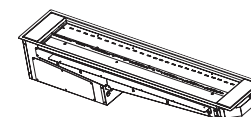

50"
PTO50 burner

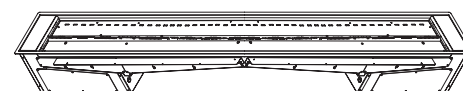

100"
Two PTO50 burners
connected end to end

* Figure will vary with individual conditions and fuel quality.



Custom application using the Regency Plateau® PTO30 burner and see-through framing kit with Stainless Steel Panels.

STANDARD FEATURES

- Natural Gas
- Stainless steel linear burner
- Combine two burners for a more impressive fire feature
- Easy access on/off switch
- Electronic ignition
- Safety valve (turns gas off if flame goes out)
- Runs on a battery pack
- Approved for outdoor installation only
- No venting required

OPTIONS

- Stainless steel burner cover
- Crystals or firebeads in various colors (must choose)
- Volcanic stones in various colors
- Ceramic driftwood log set
- Tempered glass wind shield (4-pc) with seasonal weather cover - recommended
- Table framing kits (includes ventilation grills)
- See-through framing kit (PTO30 only)
- Optional 3pc brushed stainless steel panels (top + sides) for see-through framing kit
- Hardwire kit (hardwire directly into household wiring)
- Propane conversion kit

FINISHING OPTIONS

CRYSTALS & FIREBEADS



Crystals - Black

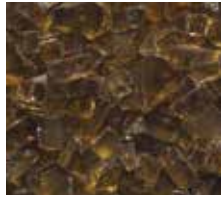

Crystals - Copper

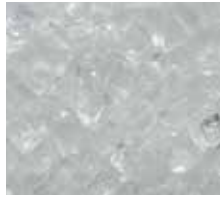

Crystals - Starfire



Firebeads - Black



Firebeads - Caramel Luster



Firebeads - Glacier Ice

STONES & LOGS



Volcanic Stones - Gray



Volcanic Stones - Tan



River Pebbles
(HZO42 only)



Driftwood Ceramic Log Set

COFFEE FIRETABLE TOP OPTIONS



Stainless Steel



Sunset Bronze

ADDITIONAL OPTIONS



Exquisitely finished tempered glass for maximum safety and optimum fire viewing (Table top version shown)



Matching burner cover protects the burner, when not in use (not available for HZO42)

FRAMING KITS

1-2-3 INSTANT FIREPLACE - HZO42



No fireplace? No problem! The Regency steel framing kit allows you to install and finish your outdoor gas fireplace in no time...

DIMENSIONS: 60" W x 20" D x 52-1/2" H

PTO30 SEE-THROUGH FRAMING KIT

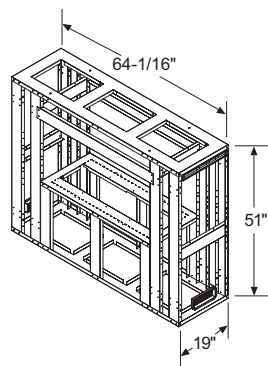

Custom application using the Regency Plateau™ PTO30 burner and see-through framing kit with Stainless Steel Panels.

NOTE: Ventilation grills are required for all enclosures. This is to alleviate moisture and allow air to circulate. Depending on model either 2 or 4 ventilation grills with a minimum 20 sq in. for each grill are required. See manual for details.

HARD WIRE KIT

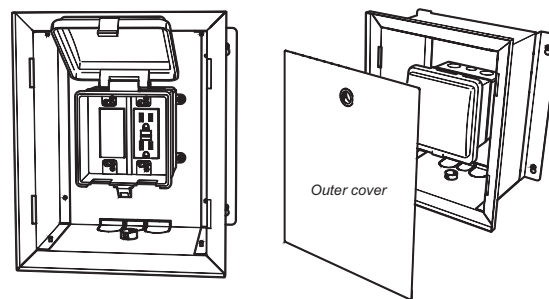

Hard wire kit is perfect for residential or commercial applications (not available for PTO30CFT).

TABLE FRAMING KIT

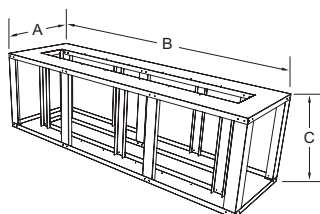

NOTE: Finishing materials are not included with framing kits.

FRAMING	50"	60"
A	24"	24"
B	69"	79"
C	24"	24"

DIMENSIONS

PTO30

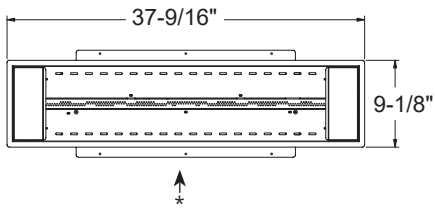

PTO50

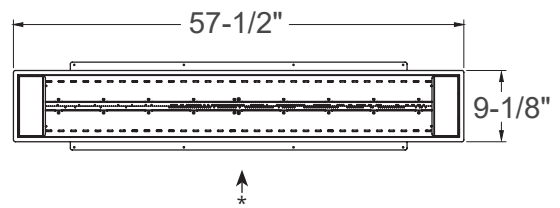

PTO60 (2 X PTO30 JOINED END TO END)

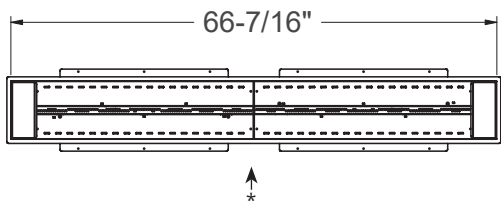

PTO80 (PTO30 & PTO50 JOINED END TO END)

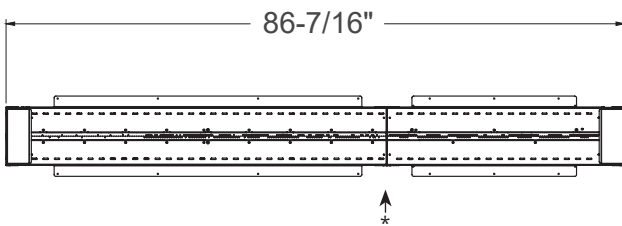

PTO100 (2 X PTO50 JOINED END TO END)

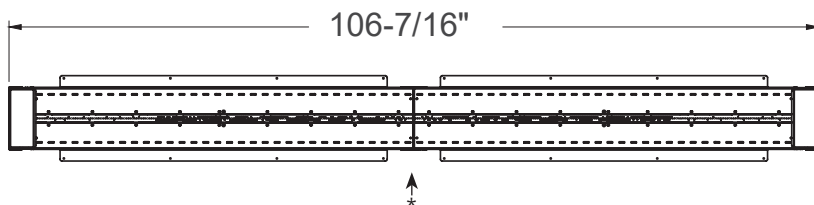

*NOTE: Gas Connection/Electrical connection locations if using optional Hardwire Kit.

DIMENSIONS

SPECIFICATIONS HZO42

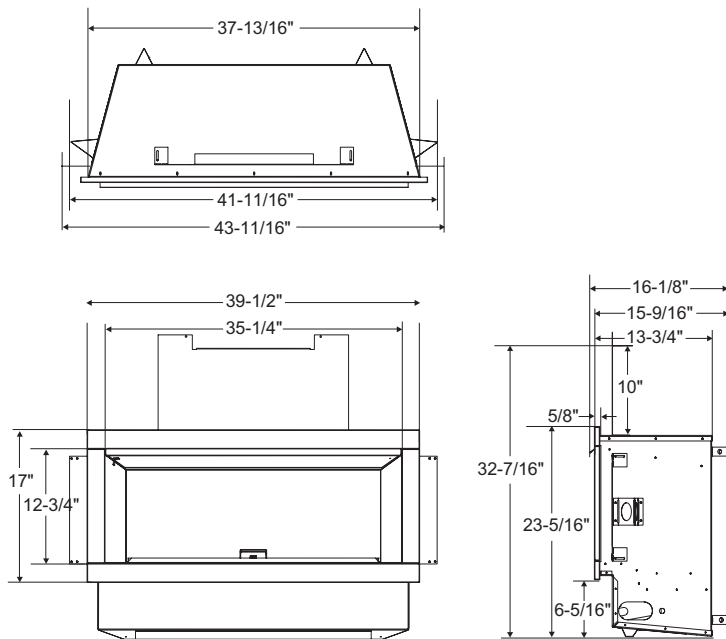

NOTE: Gas Connection/Electrical connections if using optional Hardwire Kit are located on left hand side of appliance.

SPECIFICATIONS HZO60 Single sided and see-through

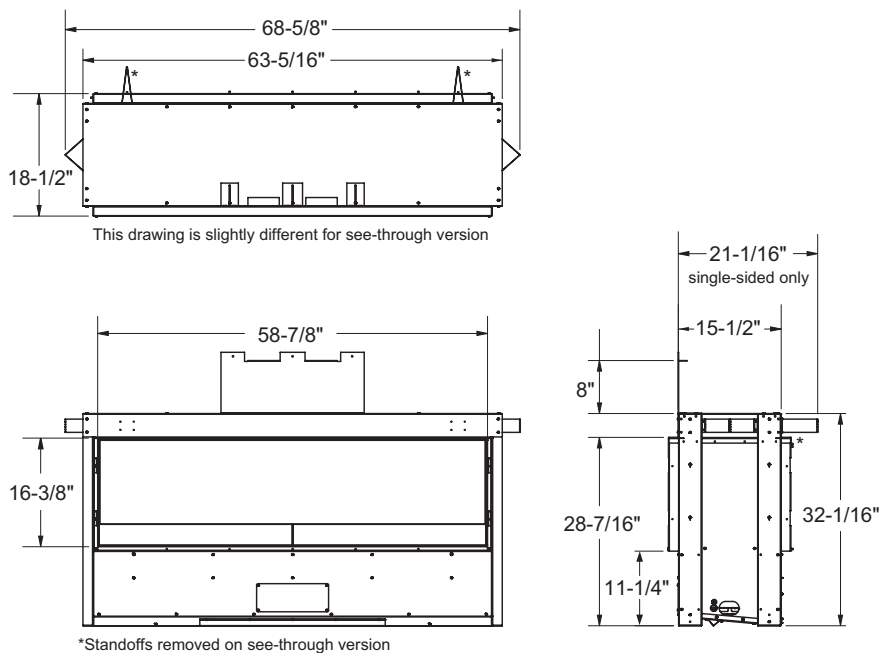

NOTE: Gas Connection/Electrical connections if using optional Hardwire Kit are located on left hand side of appliance.

DIMENSIONS

FRAMING

	HZO42	HZO60
J	42-3/16"	69"
K	32-11/16"	40-1/4"
L	20"	22-1/4"
M	52-1/2"	43-3/4"
N	40-7/16"	76-13/16"*
O	54-3/16"	108-5/8"*
P	60"	--

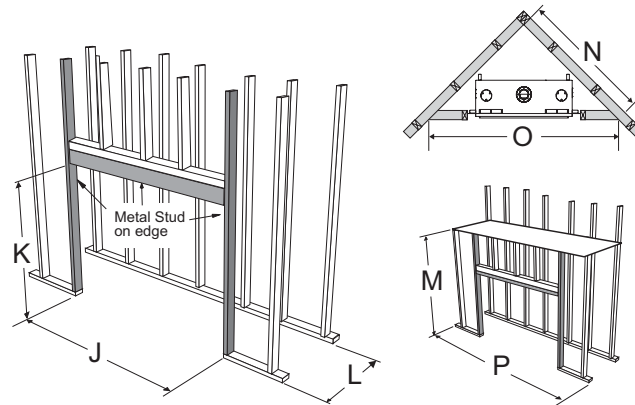

*Single sided only

Note: Please refer to the manual for specific framing instructions for the see through configuration.

CLEARANCES

	HZO42	HZO60*
A (min)	18"	22"
B	11"	11"
C	36"	36"
D (max)	12"	12"
E	57"	86"
F	36"	36"

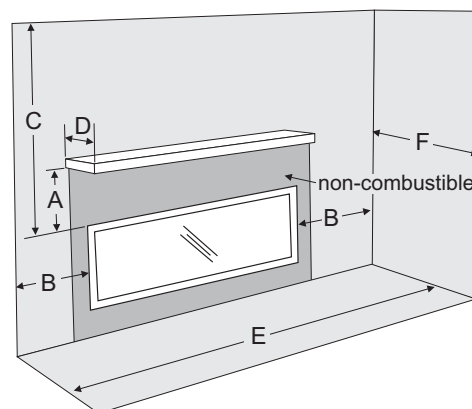

* The same clearances apply for the see through configuration.

NOTE: All product specifications are subject to change without notice. Before installing refer to the relevant product manual for full and up to date information. Manuals can be downloaded from our website www.regency-fire.com

INSTALLATION OPTIONS - G1200P, G800EH, G800EC, G800C

Non-Combustible Finishing Install

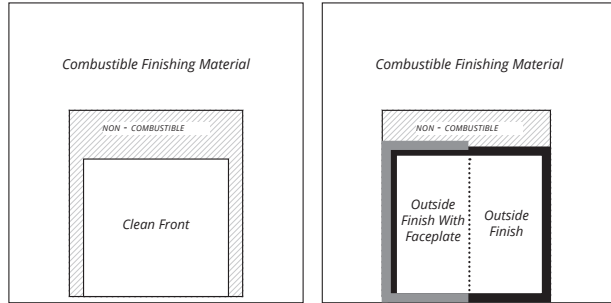

Combustible Finishing Install with Cool Wall

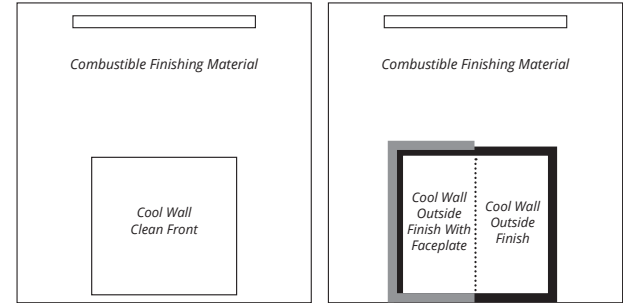

OPTIONS	G800EC	G800C	G800EH	G1200P
Cool Wall Option	Optional	Optional	Optional	Optional
Min. Cool Wall Opening	66 sq. in.	66 sq. in.	107 sq. in.	180 sq. in.
Min. Enclosure Ceiling	80" Cool Wall or 62" non-Cool Wall	80" Cool Wall or 62" non-Cool Wall	84" Cool Wall or non-Cool Wall	88" Cool Wall or 96" non-Cool Wall

DIMENSIONS - G1200P

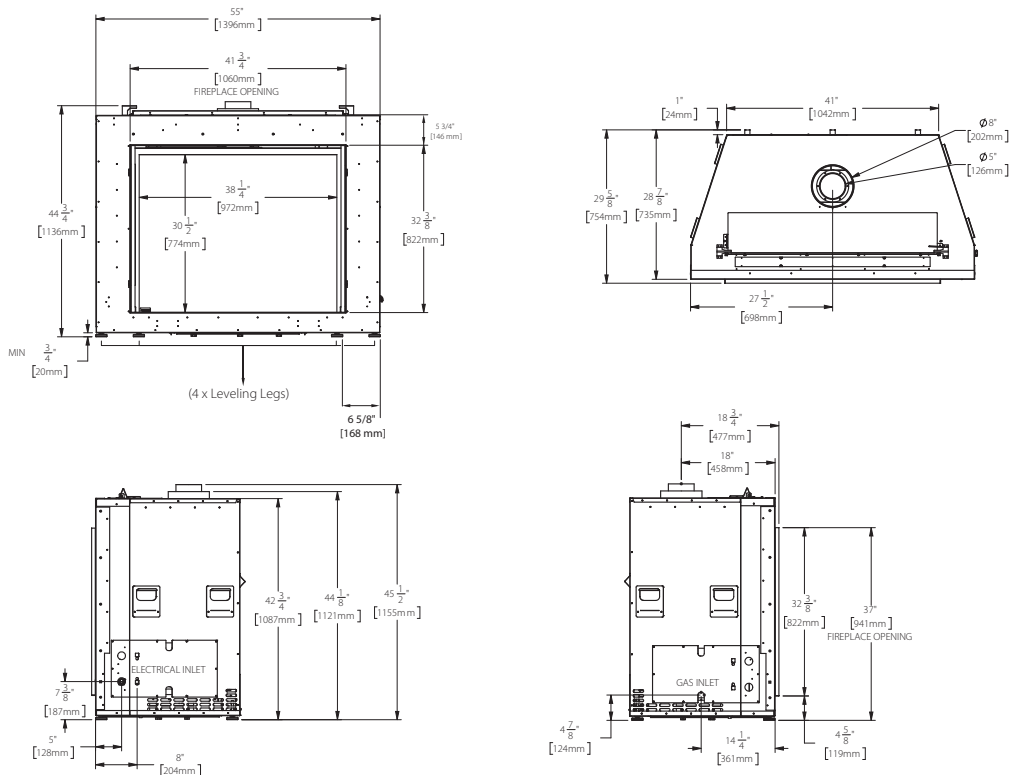

For installation, framing and clearances see manuals on our website: www.regency-fire.com

NOTE: All product specifications are subject to change without notice. Before installing refer to the relevant product manual for full and up-to-date information.

SPECIFICATIONS

DIMENSIONS - G800EC, G800C

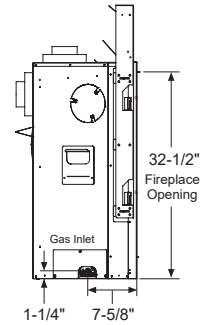
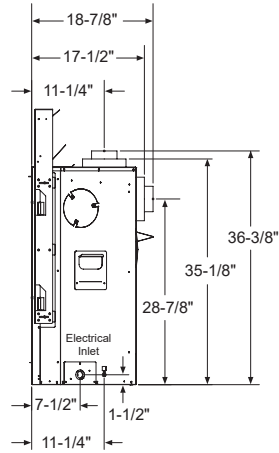
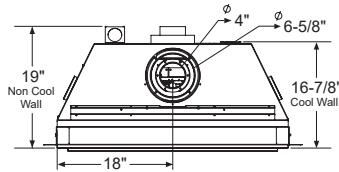
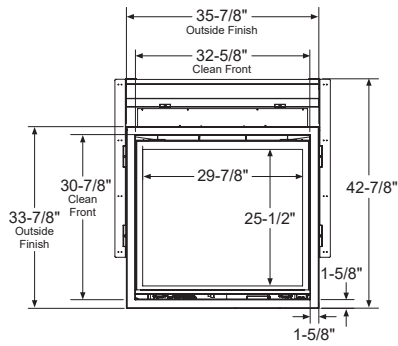

DIMENSIONS - G800EH

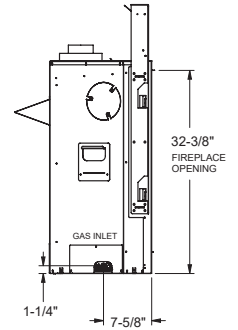
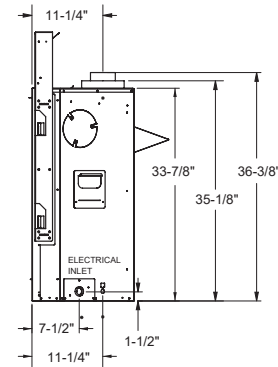
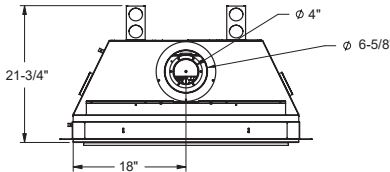
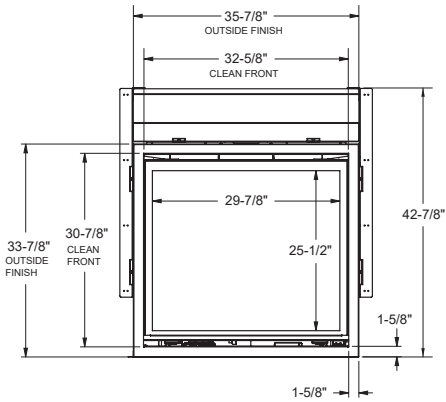

DIMENSIONS - G600EC, G600C

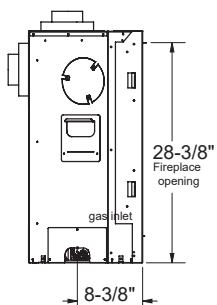
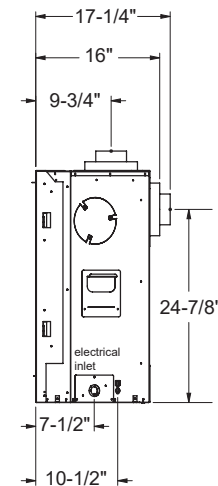
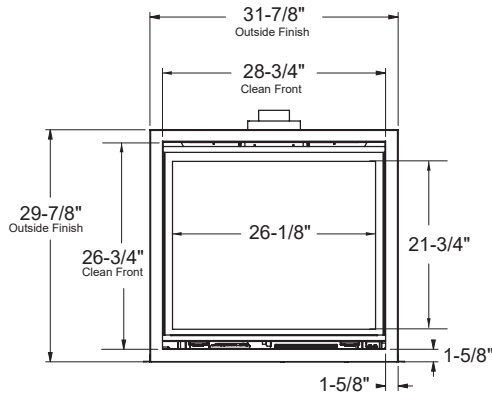
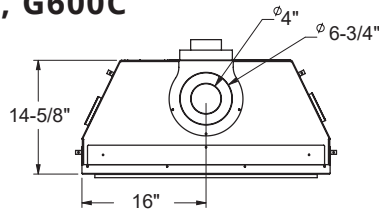

READY TO BUY



QUALITY GUARANTEED - INDUSTRY LEADING WARRANTIES

All Regency Fireplaces are manufactured in North America in our state-of-the-art manufacturing facility. When choosing to purchase a Regency fireplace, you choose high-quality craftsmanship, top-tier materials, and industry-leading support!

Add the warmth and comfort of a fireplace to your home, create memories that will last a lifetime, and rest easy knowing that your Regency is backed by the best warranty in the industry.

We have also carefully selected a dealer network that is committed to your satisfaction. We know that you will be as proud of your Regency as we are.



Find More Products at **REGENCY-FIRE.COM**

Your Regency Dealer

©2025 FPI Fireplace Products International Ltd. Regency®, Regency Horizon™ and Regency Plateau® are the registered or proprietary trademarks of FPI Fireplace Products International Ltd. All rights reserved. Printed in Canada (02/25) Part no. 944-406

Version No: 2025-1